

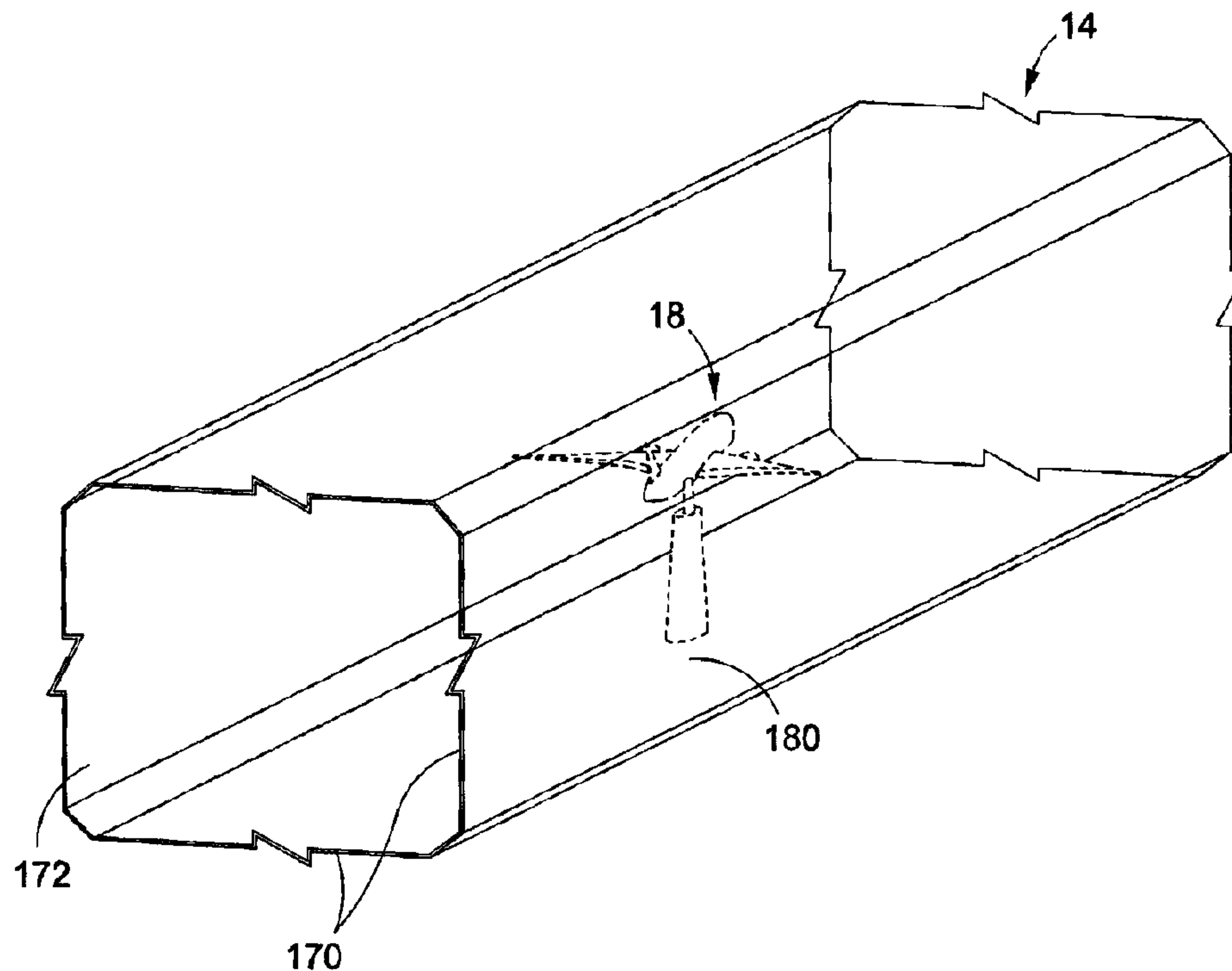

(22) Date de dépôt/Filing Date: 2013/01/31
(41) Mise à la disp. pub./Open to Public Insp.: 2013/11/14
(45) Date de délivrance/Issue Date: 2015/05/19
(30) Priorité/Priority: 2012/05/14 (US13/471,386)

(51) Cl.Int./Int.Cl. *G01M 9/06* (2006.01),
B64F 5/00 (2006.01), *G01M 9/08* (2006.01)
(72) Inventeur/Inventor:
SMITH, CLAYTON A., US
(73) Propriétaire/Owner:
THE BOEING COMPANY, US
(74) Agent: SMART & BIGGAR

(54) Titre : SYSTEME ET PROCEDURE DE MESURE DE MAQUETTE DE SOUFFLERIE
(54) Title: WIND TUNNEL MODEL MEASURING SYSTEM AND METHOD



(57) **Abrégé/Abstract:**

There is provided a wind tunnel model measuring system for use with a wind tunnel. The system has a measuring assembly with an automated movable structure with at least one measuring device mounted thereon and configured for placement within the wind tunnel, and a measuring controller device located outside the wind tunnel to control the automated movable structure in order to remotely move the automated movable structure from a storage position within the wind tunnel to one or more operating positions with respect to a wind tunnel model within the wind tunnel and to allow the at least one measuring device to determine a relative position of at least one movable first with respect to a second component, both of the wind tunnel model. The system further has a processing device configured for placement outside the wind tunnel and coupled to the measuring controller device.



ABSTRACT

There is provided a wind tunnel model measuring system for use with a wind tunnel. The system has a measuring assembly with an automated movable structure with at least one measuring device mounted thereon and configured for placement within the wind tunnel, and a measuring controller device located outside the wind tunnel to control the automated movable structure in order to remotely move the automated movable structure from a storage position within the wind tunnel to one or more operating positions with respect to a wind tunnel model within the wind tunnel and to allow the at least one measuring device to determine a relative position of at least one movable first component with respect to a second component, both of the wind tunnel model. The system further has a processing device configured for placement outside the wind tunnel and coupled to the measuring controller device.

WIND TUNNEL MODEL MEASURING SYSTEM AND METHOD

BACKGROUND

The disclosure relates generally to systems and methods for wind tunnel testing, and more particularly, to systems and methods for automated wind tunnel testing for aircraft
5 wind tunnel models.

A wind tunnel may be used to test aerodynamic surfaces of a small scale wind tunnel model, such as a small scale aircraft model or an aircraft part. The small scale wind tunnel model is typically secured within the wind tunnel while air moves past it to simulate the same flight conditions a full-sized aircraft would encounter in flight. Measurements
10 which would be difficult or impossible to take while a full-sized aircraft is in flight may be easily and safely taken with wind tunnel testing of small scale wind tunnel models. By taking accurate measurements of the aerodynamic forces on the small scale wind tunnel model, one may predict the forces on a full-sized aircraft. The measurements and data obtained from wind tunnel testing of small scale wind tunnel models allow aircraft manufacturers to better
15 understand and improve the performance of a full-sized aircraft.

Known hard tooling and measurement devices for wind tunnel model measurement exist. However, such known hard tooling and measurement devices may require wind tunnel access, wind tunnel model changes, and hand recorded documentation, all which may result in lengthy wind tunnel down time. Such lengthy wind tunnel down time
20 may, in turn, increase the wind tunnel testing time and may result in increased costs of testing.

In addition, known automated measuring devices exist for wind tunnel model measurement. Such known automated devices move and measure themselves with internal circuitry. However, such known automated measuring devices may be costly and complicated to fit on the wind tunnel model or within the wind tunnel. During wind tunnel testing, numerous of such automated measuring devices, e.g., 80 or more, may need to be attached to the aircraft wind tunnel model in order to measure different moving parts of the aircraft wind tunnel model. However, for example, the wing tip of an aircraft wind tunnel model may only be about an inch thick and fitting several or more automated measuring devices to the wing tip may be difficult.

10 In addition to the increased costs that may be associated with such known hard tooling and measurement devices and such known automated measuring devices, those performing the wind tunnel testing measurements may misuse the tools, may record incorrect measurements, or may fail to record certain measurements.

15 Accordingly, there is a need in the art for an improved wind tunnel model measuring system and method that provide advantages over known devices, systems and methods.

SUMMARY

As discussed in the below detailed description, embodiments of such improved system and method may provide significant advantages over existing devices, systems and methods.

20

In one embodiment there is provided a wind tunnel model measuring system for use with a wind tunnel. The wind tunnel model measuring system comprises a measuring assembly. The measuring assembly comprises an automated movable structure with at least one measuring device mounted thereon and configured for placement within the wind tunnel.

5 The measuring assembly further comprises a measuring controller device located outside the wind tunnel to control the automated movable structure in order to remotely move the automated movable structure from a storage position within the wind tunnel to one or more operating positions with respect to a wind tunnel model within the wind tunnel and to allow the at least one measuring device to determine a relative position of at least one movable first

10 component of the wind tunnel model with respect to a second component of the wind tunnel model. The wind tunnel model measuring system further comprises a processing device configured for placement outside the wind tunnel and coupled to the measuring controller device.

In another embodiment there is provided a wind tunnel incorporating a wind tunnel model measuring system. The wind tunnel comprises a plurality of walls defining a

15 wind tunnel structure, and at least one of the plurality of walls defining a closet portion. The wind tunnel further comprises a motorized fan mounted within a fan portion of the wind tunnel structure. The wind tunnel further comprises a wind tunnel model measuring system with a measuring assembly. The measuring assembly comprises an automated movable

20 structure with at least one measuring device mounted thereon and configured for placement within the wind tunnel. The measuring assembly further comprises a measuring controller device located outside the wind tunnel to control the automated movable structure in order to

remotely move the automated movable structure from a storage position within the closet portion of the wind tunnel to one or more operating positions with respect to a wind tunnel model within the wind tunnel and to allow the at least one measuring device to determine a relative position of at least one movable first component of the wind tunnel model with respect to a second component of the wind tunnel model, the second component coupled to the at least one movable first component. The wind tunnel model measuring system further comprises a computer configured for placement outside the wind tunnel and coupled to the measuring controller device to process an output of relational measurements obtained by the at least one measuring device of the at least one movable first component with respect to the second component.

In another embodiment there is provided a method for positioning and measuring wind tunnel model components within a pressurized wind tunnel. The method comprises installing in a wind tunnel, a wind tunnel model and a wind tunnel model positioning and measuring system. The wind tunnel model has at least one movable first component and a second component coupled to the at least one movable first component. The wind tunnel model positioning and measuring system comprises a positioning assembly and a measuring assembly. The measuring assembly has an automated movable structure with at least one measuring device mounted thereon. The method further comprises adjusting with the positioning assembly a relative position of the at least one movable first component with respect to the second component. The method further comprises moving within a pressurized wind tunnel the automated movable structure with the at least one measuring device, from a storage position that does not influence an air flow across the wind tunnel model, to one or

more operating positions with respect to the wind tunnel model. The method further comprises measuring and verifying with the at least one measuring device the relative position of the at least one movable first component with respect to the second component.

In another embodiment, there is provided a wind tunnel model measuring system for use with a wind tunnel, the system comprising a wind tunnel model configured for placement within the wind tunnel, the wind tunnel model comprising at least one first component and a second component. The at least one first component of the wind tunnel model is movable with respect to the second component of the wind tunnel model. The system further comprises a measuring assembly comprising: an automated movable structure with at least one measuring device mounted thereon and configured for placement within the wind tunnel; and, a measuring controller device located outside the wind tunnel to control the automated movable structure in order to remotely move the automated movable structure from a storage position within the wind tunnel to one or more operating positions with respect to the wind tunnel model when the wind tunnel model is within the wind tunnel and to allow the at least one measuring device to determine a relative position of the at least one movable first component of the wind tunnel model with respect to the second component of the wind tunnel model. The system further comprises a processing device configured for placement outside the wind tunnel and coupled to the measuring controller device.

The wind tunnel model measuring system may further comprise a positioning assembly comprising: at least one automated actuating element operable for coupling to the at least one movable first component of the wind tunnel model; and, a positioning controller device configured to be located outside the wind tunnel and further configured to control the at

least one automated actuating element in order to remotely adjust the relative position of the at least one movable first component with respect to the second component of the wind tunnel model.

The processing device may comprise a computer configured to process an output of
5 relational measurements obtained by the at least one measuring device.

The wind tunnel model may be an aircraft wind tunnel model. The at least one movable first component may be a leading edge device coupled to a wing of the aircraft wind tunnel model and the second component may be the wing of the aircraft wind tunnel model.

The processing device may comprise a computer configured to process an output of
10 relational measurements obtained by the at least one measuring device. The output of relational measurements may comprise a leading edge gap measurement between a trailing edge point of the leading edge device and a forward edge of the wing, a leading edge height measurement between the trailing edge point of the leading edge device and a flat reference surface of the wing, or a leading edge angle measurement between a flat reference surface of
15 the leading edge device and a flat reference surface of the wing, or a combination of two or more thereof.

The wind tunnel model may be an aircraft wind tunnel model. The at least one movable first component may be a trailing edge device coupled to a wing of the aircraft wind tunnel model and the second component may be the wing of the aircraft wind tunnel model.

The processing device may comprise a computer configured to process an output of relational measurements obtained by the at least one measuring device. The output of relational measurements may comprise a trailing edge gap measurement between an upper leading edge point of the trailing edge device and a trailing edge point of a spoiler of the wing, or a trailing edge overlap measurement between the upper leading edge point of the trailing edge device and a lower leading edge point of the trailing edge device and between the trailing edge point of the spoiler of the wing and a spoiler portion of the wing, or both the trailing edge gap measurement and the trailing edge overlap measurement.

The at least one measuring device may comprise a laser, an optical camera, a digital camera, or a profilometer, a combination of two or more thereof.

The at least one measuring device may be operable to measure a two-dimensional section of the relative position of the at least one movable first component with respect to the second component.

The automated movable structure may comprise a traversing arm structure.

The traversing arm structure may be powered by an electric motor.

The traversing arm structure may be configured to provide translation motion to the at least one measuring device.

The traversing arm structure may be configured to provide rotary motion to the at least one measuring device.

The traversing arm structure may be operable from the storage position within the wind tunnel.

The storage position may be configured such that the traversing arm structure does not influence an air flow across the wind tunnel model.

5 The second component of the wind tunnel model may be coupled to the at least one movable first component of the wind tunnel model.

The second component of the wind tunnel model may be hinged to the at least one movable first component of the wind tunnel model.

10 The second component of the wind tunnel model may be coupled with a pivot to the at least one movable first component of the wind tunnel model.

In another embodiment, there is provided a wind tunnel incorporating the wind tunnel model measuring system, the wind tunnel comprising a plurality of walls defining a wind tunnel structure of the wind tunnel, and at least one of the plurality of walls defining a closet portion. The storage position is within the closet portion. The wind tunnel further comprises a motorized fan mounted within a fan portion of the wind tunnel structure.

15

In another embodiment, there is provided a method for positioning and measuring wind tunnel model components within a pressurized wind tunnel, the wind tunnel comprising a wind tunnel model and a wind tunnel model positioning and measuring system in the wind tunnel, the wind tunnel model having at least one movable first component and a second component coupled to the at least one movable first component, the wind tunnel model

20

positioning and measuring system comprising a positioning assembly and a measuring assembly, the measuring assembly having an automated movable structure with at least one measuring device mounted thereon, the method comprising: adjusting with the positioning assembly a relative position of the at least one movable first component with respect to the
5 second component; moving within the pressurized wind tunnel the automated movable structure with the at least one measuring device, from a storage position that does not influence an air flow across the wind tunnel model, to one or more operating positions with respect to the wind tunnel model; and, measuring and verifying with the at least one measuring device the relative position of the at least one movable first component with respect to the
10 second component.

The method may further comprise obtaining with the at least one measuring device an output of relational measurements of the at least one movable first component with respect to the second component, and processing the output of relational measurements with a computer.

Obtaining with the at least one measuring device may comprise receiving a leading
15 edge gap measurement between a trailing edge point of a leading edge device and a forward edge of a wing, a leading edge height measurement between the trailing edge point of the leading edge device and a flat reference surface of the wing, a leading edge angle measurement between a flat reference surface of a leading edge device and a flat reference surface of the wing, a trailing edge gap measurement between an upper leading edge point of a
20 trailing edge device and a trailing edge point of a spoiler of the wing, or a trailing edge overlap measurement between the upper leading edge point of the trailing edge device and a lower

leading edge point of the trailing edge device and between the trailing edge point of the spoiler of the wing and a spoiler portion of the wing, or a combination of two or more thereof.

Adjusting with the positioning assembly may comprise operating at least one automated actuating element coupled to the at least one movable first component via a positioning controller device configured to be located outside the wind tunnel.

Adjusting with the positioning assembly may comprise controlling operation of the positioning assembly using a computer configured for placement outside the wind tunnel and coupled to the positioning controller device.

Adjusting with the positioning assembly may comprise pivoting the at least one movable first component with respect to the second component.

The measuring and verifying with the at least one measuring device may comprise measuring a two-dimensional section of the relative position of the at least one movable first component with respect to the second component without depressurization of the wind tunnel.

Moving within the pressurized wind tunnel the automated movable structure with the at least one measuring device may comprise moving a traversing arm structure.

Moving the traversing arm structure may comprise moving the traversing arm structure using an electric motor.

Measuring and verifying with the at least one measuring device may comprise measuring and verifying using a laser, an optical camera, a digital camera, or a profilometer, or two or more thereof.

Adjusting with the positioning assembly may comprise adjusting of a leading edge
5 device or a trailing edge device, or both, relative to a wing of an aircraft wind tunnel model.

The features, functions, and advantages that have been discussed can be achieved independently in various embodiments of the disclosure or may be combined in yet other embodiments further details of which can be seen with reference to the following description and drawings.

10 **BRIEF DESCRIPTION OF THE DRAWINGS**

The disclosure can be better understood with reference to the following detailed description taken in conjunction with the accompanying drawings which illustrate preferred and exemplary embodiments, but which are not necessarily drawn to scale, wherein:

FIG. 1A is an illustration of a block diagram showing one of the embodiments of a
15 wind tunnel model positioning and measuring system and one of the embodiments of a wind tunnel model measuring system of the disclosure;

FIG. 1B is an illustration of a system diagram showing an embodiment of a wind tunnel incorporating one of the embodiments of a wind tunnel model positioning and measuring system and one of the embodiments of a wind tunnel model measuring system of
20 the disclosure;

FIG. 1C is an illustration of a block diagram showing an output of relational measurements measured by one of the embodiments of a wind tunnel model measuring system of the disclosure;

5 FIG. 2A is an illustration of a perspective view showing in partial an aircraft wind tunnel with an aircraft wind tunnel model mounted therein that may be used with one of the embodiments of a wind tunnel model measuring system of the disclosure;

FIG. 2B is an illustration of a close-up perspective view of the aircraft wind tunnel model of FIG. 2A;

10 FIG. 2C is an illustration of a perspective view showing in partial the aircraft wind tunnel and the aircraft wind tunnel model of FIG. 2A with one of the embodiments of an automated movable structure of the wind tunnel model measuring system in a storage position;

15 FIG. 2D is an illustration of a perspective view showing in partial the aircraft wind tunnel and the aircraft wind tunnel model of FIG. 2C with the automated movable structure in an operating position moved adjacent the aircraft wind tunnel model;

FIG. 2E is an illustration of a back perspective view showing the aircraft wind tunnel model of FIG. 2D with the automated movable structure in an operating position measuring a trailing edge device;

FIG. 2F is an illustration of a front perspective view showing the aircraft wind tunnel model of FIG. 2E with the automated movable structure in an operating position measuring a leading edge device;

5 FIG. 3 is an illustration of a perspective view of one of the embodiments of a test model of a leading edge device that may be used with one of the embodiments of a wind tunnel model measuring system of the disclosure;

FIG. 4 is an illustration of a perspective view of one of the embodiments of a test model of a trailing edge device that may be used with one of the embodiments of a wind tunnel model measuring system of the disclosure;

10 FIG. 5 is an illustration of a sectional view of one of the embodiments of a leading edge device showing a leading edge gap measurement and a leading edge height measurement;

FIG. 6 is an illustration of a sectional view of one of the embodiments of a leading edge device showing a leading edge angle measurement;

15 FIG. 7 is an illustration of a partial sectional view of one of the embodiments of a trailing edge device showing a trailing edge gap measurement and a trailing edge overlap measurement; and,

FIG. 8 is an illustration of a flow diagram showing an embodiment of a method of the disclosure.

DETAILED DESCRIPTION

Disclosed embodiments will now be described more fully hereinafter with reference to the accompanying drawings, in which some, but not all of the disclosed embodiments are shown. Indeed, several different embodiments may be provided and should not be construed as limited to the embodiments set forth herein. Rather, these embodiments are provided so that this disclosure will be thorough and complete and will fully convey the scope of the disclosure to those skilled in the art.

Now referring to the Figures, FIG. 1A is an illustration of a block diagram showing one of the embodiments of a wind tunnel model positioning and measuring system **10** of the disclosure, and one of the embodiment of a wind tunnel model measuring system **11**. The wind tunnel model positioning and measuring system **10** and the wind tunnel model measuring system **11** are preferably used with a wind tunnel model **16** (see FIG. 1A) in a wind tunnel **12** (see FIG. 1A). Preferably, the wind tunnel **12** comprises an aircraft wind tunnel **14** (see FIG. 1A). Preferably, the wind tunnel model **16** comprises an aircraft wind tunnel model **18** (see FIG. 1A). However, the wind tunnel **12** may also be a wind tunnel for automobiles, such as race cars, for trucks, such as semi trucks, for missiles, such as aircraft missiles, or for other suitable vehicles.

FIG. 1B is an illustration of a system diagram showing an embodiment of a wind tunnel **12** incorporating one of the embodiments of a wind tunnel model positioning and measuring system **10** and incorporating one of the embodiments of the wind tunnel model measuring system **11** of the disclosure. As shown in FIG. 1B, the wind tunnel **12** comprises a plurality of walls **170** defining a wind tunnel structure **172**. At least one of the plurality of

walls **170** defines a closet portion **94** (see FIG. 1B). The wind tunnel **12** may further comprise a motorized fan **174** with a fan motor **176** mounted within a fan portion **178** of the wind tunnel structure **172**. Preferably, the wind tunnel **12** is pressurized.

As shown in FIG. 1B, the wind tunnel **12** may further comprise a wind tunnel model **16** mounted within a test portion **180** of the wind tunnel structure **172**. The wind tunnel model **16** comprises at least one movable first component **20** (see FIGS. 1A, 1B) and a second component **22** (see FIGS. 1A, 1B) that may be movable or fixed. The at least one movable first component **20** is preferably coupled to the second component **22**. The at least one movable first component **20** may comprise a leading edge device **24** (see FIGS. 1A, 3), a trailing edge device **26** (see FIGS. 1A, 4), or another suitable movable device on the wind tunnel model **16**. The at least one movable first component **20** and the second component **22** may also comprise, for example, automobile panels, automobile tires, automobile spoilers, intake or exhaust vents, automobile and semi truck fairings, side mirrors, and other components, or other suitable components.

For purposes of this application, a leading edge device **24** means a movable part on a front portion **28** (see FIG. 2B) of a wing **30** (see FIGS. 1A, 2B) or a movable part of a tail **32** (see FIGS. 1A, 2B) on, for example, the aircraft wind tunnel model **16** (see FIG. 2B), that first contacts an air flow **34** (see FIGS. 1A, 1B) introduced through the wind tunnel **12**. Examples of leading edge devices **24** may include slats **36** (see FIGS. 2B, 5) which are aerodynamic surfaces on the leading edge device **24** that increase lift; slots **38** (see FIG. 5) which are span-wise gaps in the wing **30** that allow air flow **34** (see FIG. 1B) to flow from

below the wing **30** to the upper surface of the wing **30** to reduce stall speed; leading edge flaps **40** (see FIG. **3**), such as Krueger flaps **41** (see FIG. **3**), which are hinged flaps that fold out from under the leading edge of the wing **30**, while not forming a part of the leading edge of the wing when retracted, and which may be used to reduce speed and increase lift and drag; and extensions (not shown) which are small extensions forward of the leading edge of the leading edge device **24**. The leading edge device **24** may also comprise other suitable movable parts on the front portion **28** (see FIG. **2B**) of the wing **30** (see FIG. **2B**) or movable parts of the tail **32** (see FIG. **2B**).

FIG. **3** is an illustration of a perspective view of one of the embodiments of a test model **184** of a leading edge device **24** that may be used with one of the embodiments of the wind tunnel model positioning and measuring system **10** (see FIG. **1A**) of the disclosure. The test model **184** of the leading edge device **24**, as shown in FIG. **3**, comprises a leading edge flap **40** in the form of a Krueger flap **41**. As shown in FIG. **3**, the Krueger flap **41** is attached to pivot mounts **186** secured to a base plate **188**.

For purposes of this application, a trailing edge device **24** means a movable part on a rear portion **42** (see FIG. **2B**) of the wing **30** or the tail **32** on, for example, the aircraft wind tunnel model **16** (see FIG. **2B**), where the air flow **34** separated by the leading edge device **24** rejoins. Examples of trailing edge devices **26** may include trailing edge flaps **44** (see FIG. **4**), such as plain flaps, slotted flaps, Fowler flaps or other trailing edge flaps **44**, which may be used to reduce speed and increase lift drag; ailerons **46** (see FIG. **2B**), which are hinged flight control surfaces used to provide lateral roll and control roll; spoilers **48** (see

FIG. 7) which are devices on the upper surface of the wing **30** that disrupt the air flow **34** and create drag rather than lift; and flaperons (not shown) which are a combination of a trailing edge flap **44** and an aileron **46** that work together to increase lift. The trailing edge device **26** may also comprise other suitable movable parts on the rear portion **42** of the wing **30** or the tail **32**.

FIG. 4 is an illustration of a perspective view of one of the embodiments of a test model **190** of a trailing edge device **26** that may be used with one of the embodiments of the wind tunnel model positioning and measuring system **10** (see FIG. 1A) of the disclosure. The test model **190** of the trailing edge device **26**, as shown in FIG. 4, comprises a trailing edge flap **44**. As shown in FIG. 4, the trailing edge flap **44** is attached to bracketed pivot mounts **192** secured to a base plate **194**.

As shown in FIG. 1B, the wind tunnel **12** further comprises a wind tunnel model positioning and measuring system **10** and a wind tunnel model measuring system **11**. As shown in FIG. 1A, the wind tunnel model positioning and measuring system **10** includes the wind tunnel model measuring system **11**. The wind tunnel model measuring system **11** is preferably for use with a wind tunnel **12** (see FIG. 1A). In one embodiment, as shown in FIGS. 1A, 1B, the wind tunnel model measuring system **11** comprises a measuring assembly **70**.

The measuring assembly **70** comprises an automated movable structure **72** (see FIGS. 1A, 1B, 2E) configured for placement within the wind tunnel **12**. As shown in FIGS. 2D, 2E), the automated movable structure **72** has a first end **74**, a second end **76**, and an

articulating body portion **78**. Preferably, the automated movable structure **72** comprises a traversing arm structure **80** (see FIGS. 1A, 1B, 2D, 2E), such as a robotic traversing arm structure, or other type of automated traversing structure. The traversing arm structure **80** may provide rotation about a vertical axis, elevation out of a horizontal plane, and translation and rotary motion. This allows the traversing arm structure **80** to be capable of reaching into confined spaces.

The first end **74** of the automated movable structure **72** is preferably coupled to a power source **82** (see FIG. 1A). The automated movable structure **72** is preferably operated or powered by a power source **82** (see FIGS. 1A, 1B, 2D, 2E), such as an electric motor **84** (see FIG. 1A), or another power source **82**, such as a hydraulic power source (not shown) or a pneumatic power source (not shown). The automated movable structure **72** further has at least one measuring device **86** (see FIGS. 1A, 1B, 2D, 2E) mounted thereon, preferably at the second end **76** (see FIGS. 2D, 2E). The at least one measuring device **86** may comprise a laser device **88** (see FIGS. 1A, 2E), an optical camera **90** (see FIG. 1A), a digital camera **92** (see FIG. 1A), a profilometer **93** (a measuring instrument used to measure a surface's profile in order to quantify its roughness), or another contact or non-contact device capable of obtaining contour measurements of a surface, or another suitable measuring device **86**.

The automated movable structure **72** may be stored in a closet portion **94** (see FIGS. 1A, 1B) of the wind tunnel **12** or stored in another enclosed portion of the wind tunnel **12**. When not in operation, the automated movable structure **72** is preferably stored in the closet portion **94** in a storage position **96** (see FIGS. 1A, 2C). The storage position **96** is

configured such that the automated movable structure **72**, such as in the form of traversing arm structure **80**, does not influence the air flow **34** (see FIGS. 1A, 1B) across the wind tunnel model **16**. When in operation, the automated movable structure **72** moves from the storage position **96** to one or more operating positions **98** (see FIGS. 1A, 2D, 2F), for example, operating position **98a** (see FIG. 2E) or operating position **98b** (see FIG. 2F). The automated movable structure **72** does not influence the air flow **34** (see FIG. 1B) across the wind tunnel model **16** when the automated movable structure **72** is in the storage position **96**.

As further shown in FIGS. 1A, 1B, the measuring assembly **70** comprises a measuring controller device **100** located outside the wind tunnel **12**. The measuring controller device **100** is coupled to the power source **82** of the automated movable structure **72** via one or more control lines **102** (see FIG. 1B), such as one or more electrical lines, connected through a wind tunnel portion **104** (see FIG. 1B), or via a wireless connection (not shown). The measuring controller device **100** may comprise an automated controller device **106** (see FIGS. 1A, 1B) having one or more of sensors, controls, instrumentation, or other components known in the art. In certain embodiments, such as, for example, a prototype system, the measuring controller device **100** may be a separate device from the positioning controller device **60**. In other embodiments, such as, for example, a production system, the measuring controller device **100** may be a single, combined device with the positioning controller device **60**. The measuring controller device **106** is preferably used to operate or to control the power source **82** and to operate or to control the automated movable structure **72** in order to remotely move the automated movable structure **72** from the storage position **96** (see FIG. 2C) within the wind tunnel **12**, such as within a closet portion **94** (see FIGS. 1A,

1B) to the one or more operating positions **98** (see FIG. 2D) with respect to the wind tunnel model **16** within the wind tunnel **12** and to allow the at least one measuring device **86** to determine the relative position **68** (see FIG. 1A) of the at least one movable first component **20** of the wind tunnel model **16** with respect to the second component **22** of the wind tunnel model **16**. The at least one measuring device **86** preferably measures a two-dimensional section **108** (see FIGS. 1A, 2E) of the relative position **68** (see FIG. 2E) of the at least one movable first component **20** (see FIG. 2E) with respect to the second component **22** (see FIG. 2E).

As further shown in FIGS. 1A, 1B, the wind tunnel model positioning and measuring system **10** and the wind tunnel model measuring system **11** further comprise a processing device **110**, such as a computer **112**, configured for placement outside the wind tunnel **12**. As shown in FIG. 1B, the processing device **110**, such as computer **112**, may be coupled to the measuring controller device **100** via one or more measuring controller connection lines **115**. The processing device **110**, such as a computer **112**, processes an output **114** (see FIGS. 1A, 1C) of relational measurements **116** (see FIGS. 1A, 1C) of the at least one movable first component **20** to the second component **22** as measured and obtained by the at least one measuring device **86**. The output **114** of the relational measurements **116** that has been recorded may be automated into an electronic data file and algorithms and software may be developed and used to compute and process the relational measurements **116**. Such automated processing may facilitate improved reliability, efficiency, and functionality in testing.

As shown in FIGS. 1A, 1B, the wind tunnel model positioning and measuring system **10** and the wind tunnel model measuring system **11** may further comprise a positioning assembly **50**. The positioning assembly **50** comprises at least one automated actuating element **52** configured for placement within the wind tunnel **12** and operable for coupling to the at least one movable first component **20** of the wind tunnel model **16** in order to actuate or move the at least one movable first component **20**. The at least one automated actuating element **52** preferably comprises an actuator **54** (see FIGS. 1A, 1B) or other suitable device for moving the at least one movable first component **20**. The at least one automated actuating element **52** is preferably operated or powered by a power source **56** (see FIGS. 1A, 1B), such as an electric motor **58** (see FIG. 1A), or another power source **56** such as a hydraulic power source (not shown) or a pneumatic power source (not shown).

As further shown in FIGS. 1A, 1B, the positioning assembly **50** comprises a positioning controller device **60** configured to be located outside the wind tunnel **12**. The positioning controller device **60** is operable for coupling to the at least one automated actuating element **52** via one or more control lines **62** (see FIG. 1B), such as one or more electrical lines, connected through a wind tunnel portion **64** (see FIG. 1B), or via a wireless connection (not shown) to operate or control the at least one automated actuating element **52**. The positioning controller device **60** may comprise an automated controller device **66** (see FIGS. 1A, 1B) having one or more of sensors, controls, instrumentation, or other components known in the art. The positioning controller device **60** is configured to control the at least one automated actuating element **52** in order to remotely adjust the relative position **68** (see FIG. 1A) of the at least one movable first component **20** with respect to the second component **22**

of the wind tunnel model **16**. For example, the positioning controller device **60** may be used to remotely adjust the relative position **68** of the leading edge device **24**, such as a leading edge flap **40** (see FIG. **3**), to the wing **30** of the wind tunnel model **16**.

As shown in FIG. **1B**, the processing device **110**, such as computer **112**, may be coupled to the positioning controller device **60**, such as the automated controller device **66** via one or more positioning controller connection lines **113**. Alternatively, the wind tunnel model positioning and measuring system **10** and the wind tunnel model measuring system **11** may have one processing device **110**, such as computer **112**, connected to the positioning controller device **60** and another processing device **110**, such as computer **112**, connected to the measuring controller device **100**.

FIG. **1C** is an illustration of a block diagram showing the output **114** of relational measurements **116** measured by one of the embodiments of a wind tunnel model positioning and measuring system **10** or the wind tunnel model measuring system **11** of the disclosure. When the at least one movable first component **20** comprises a leading edge device **24** coupled to a wing **30** of an aircraft wind tunnel model **18**, and the second component **22** is the wing **30** of the aircraft wind tunnel model **18**, the at least one measuring device **86** preferably measures a leading edge gap measurement **118** (see FIGS. **1C**, **5**), a leading edge height measurement **120** (see FIGS. **1C**, **5**), and a leading edge angle measurement **122** (see FIGS. **1C**, **6**). When the at least one movable first component **20** comprises a trailing edge device **26** (see FIGS. **1A**, **1C**, **4**) coupled to a wing **30** of an aircraft wind tunnel model **18**, and the second component **22** is the wing **30** of the aircraft wind tunnel model **18**, the at least

one measuring device **86** preferably measures a trailing edge gap measurement **140** (see FIGS. 1C, 7) and a trailing edge overlap measurement **142** (see FIGS. 1C, 7).

FIG. 5 is an illustration of a sectional view of one of the embodiments of the leading edge device **24** showing the leading edge gap measurement **118** and the leading edge height measurement **120**. As shown in FIG. 5, the leading edge gap measurement **118** is a measurement of a gap **124** between a trailing edge point **126** of the leading edge device **24** and a forward edge **128** of the wing **30**. As further shown in FIG. 5, the leading edge height measurement **120** is a measurement of a height **130** between the trailing edge point **126** of the leading edge device **24** and a flat reference surface **132** of the wing **30**.

FIG. 6 is an illustration of a sectional view of one of the embodiments of the leading edge device **24**, in the form of a slat **36**, showing the leading edge angle measurement **122**. As shown in FIG. 6, the leading edge angle measurement **122** is a measurement of an angle **134** between a flat reference surface **136** of the leading edge device **24** and a flat reference surface **138** of the wing **30**.

FIG. 7 is an illustration of a partial sectional view of one of the embodiments of the trailing edge device **26** showing the trailing edge gap measurement **140** and the trailing edge overlap measurement **142**. As shown in FIG. 7, the trailing edge gap measurement **140** is a measurement of a gap **144** between an upper leading edge point **146** of the trailing edge device **26** and a trailing edge point **148** of a spoiler **48** of the wing **30**. As further shown in FIG. 7, the trailing edge overlap measurement **142** is a measurement of an overlap **152** of a measurement between the upper leading edge point **146** of the trailing edge device **26** and a

lower leading edge point **154** of the trailing edge device **26**, and a measurement between the trailing edge point **148** of the spoiler **48** of the wing **30** and a spoiler portion **156** of the wing **30**. FIG. 7 also shows the trailing edge device **26** in the form of a trailing edge flap **44**. The trailing edge flap **44** is shown coupled to a bracket **160** with a fixed angle. The spoiler **48** is shown coupled to a spar **150**, and the spar **150** is shown coupled to a fairing **158**.

The output **114** of relational measurements **116** measured by one of the embodiments of a wind tunnel model positioning and measuring system **10** or the wind tunnel model measuring system **11** of the disclosure may also comprise relational measurements for automobiles, trucks, missiles or other vehicles. For example, the relational measurements may comprise a measurement from an automobile part or body to an automobile spoiler, a measurement from an automobile lower panel to a surface on the ground (ride height), a measurement from one or more automobile tires to an automobile fender, a measurement of gaps between automobile body panels (under wind load), a measurement of a position of semi truck fairings, side mirrors, ride height, or other components, a measurement of a deflection of an intake vent and an exhaust vent on a vehicle, a measurement of a missile design, such as a position of a missile departing from an aircraft, or another suitable relational measurement.

FIG. 2A is an illustration of a perspective view showing in partial an aircraft wind tunnel **14** with an aircraft wind tunnel model **18** mounted therein that may be used with one of the embodiments of the wind tunnel model positioning and measuring system **10** and one of the embodiments of the wind tunnel model measuring system **11** of the disclosure. As

shown in FIG. 2A, the aircraft wind tunnel 14 comprises a plurality of walls 170 defining a wind tunnel structure 172. The aircraft wind tunnel model 18 is located in a test portion 180 of the aircraft wind tunnel 14.

5 FIG. 2B is an illustration of a close-up perspective view of the aircraft wind tunnel model 18 of FIG. 2A. The aircraft wind tunnel model 18 comprises a wing 30 having a front portion 28 and a rear portion 42. The aircraft wind tunnel model 18 further comprises a tail 32. As shown in FIG. 2B, the aircraft wind tunnel model 18 further comprises slats 36 coupled to the front portion 28 of the wing 30, spoilers 48 on the upper surface of the wing 30, and trailing edge flaps 44 and ailerons 46 coupled to the rear portion 42 of the wing 30.

10 FIG. 2C is an illustration of a perspective view showing in partial the aircraft wind tunnel 14 and the aircraft wind tunnel model 18 of FIG. 2A with one of the embodiments of the automated movable structure 72 of the measuring assembly 70 (see FIG. 1A) of the wind tunnel model measuring system 11 (see FIG. 1A). FIG. 2C shows the automated movable structure 72 in a storage position 96 with the traversing arm structure 80 positioned upright. The traversing arm structure 80 is coupled to the power source 82.

15

FIG. 2D is an illustration of a perspective view showing in partial the aircraft wind tunnel 14 and the aircraft wind tunnel model 18 of FIG. 2C with the automated movable structure 72 in an operating position 98. FIG. 2D shows the first end 74, the second end 76, and the articulating body portion 78 of the traversing arm structure 80. FIG. 2D further shows the power source 82 at the first end 74 of the traversing arm structure 80 and the at least one measuring device 86 at the second end 76 of the traversing arm structure 80.

20

FIG. 2D shows the automated movable structure **72** in an operating position **98** with the traversing arm structure **80** articulated outwardly and adjacent the aircraft wind tunnel model **18**.

FIG. 2E is an illustration of a back perspective view showing the aircraft wind tunnel model **18** of FIG. 2D with the automated movable structure **72** in an operating position **98a** using laser beams **89** from a laser device **88** to measure the relative position **68** of the at least one movable component **20** to the second component **22**, where the at least one movable component **20** comprises a trailing edge device **26**. FIG. 2E shows the first end **74**, the second end **76**, and the articulating body portion **78** of the traversing arm structure **80**. FIG. 2E further shows the power source **82** at the first end **74** of the traversing arm structure **80** and the at least one measuring device **86** at the second end **76** of the traversing arm structure **80**. FIG. 2E shows the automated movable structure **72** in an operating position **98a** with the traversing arm structure **80** articulated outwardly and adjacent the aircraft wind tunnel model **18** and with the at least one measuring device **86** in the form of laser device **88** beaming laser beams **89** onto the at least one movable component **20** and the second component **22**. The at least one measuring device **86** preferably measures and verifies a two-dimensional section **108** of the relative position **68** of the at least one movable component **20** to the second component **22**, where the at least one movable component **20** comprises a trailing edge device **26**.

FIG. 2F is an illustration of a front perspective view showing the aircraft wind tunnel model **18** of FIG. 2E with the automated movable structure **72** in an operating position

98b using laser beams 89 from the laser device 88 to measure the relative position of the at least one movable component 20 to the second component 22, where the at least one movable component 20 comprises a leading edge device 24. FIG. 2F shows the automated movable structure 72 in an operating position 98a with the traversing arm structure 80 articulated outwardly and adjacent the aircraft wind tunnel model 18 and with the laser device 88 beaming laser beams 89 onto the at least one movable component 20 and the second component 22. The laser device 88 preferably measures and verifies a two-dimensional section 108 of the relative position 68 of the at least one movable component 20 to the second component 22, where the at least one movable component 20 comprises a leading edge device 24.

FIG. 8 is an illustration of a flow diagram showing an embodiment of a method 200 of the disclosure. As shown in FIG. 8, in another embodiment, there is provided a method 200 for positioning and measuring wind tunnel model components within a wind tunnel 12 (see FIGS. 1A, 1B) that is preferably pressurized. The method 200 comprises step 202 of installing in a wind tunnel 12 (see FIGS. 1A, 1B), a wind tunnel model 16 (see FIGS. 1A, 1B) and a wind tunnel model positioning and measuring system 10 (see FIGS. 1A, 1B).

The wind tunnel model 16 (see FIGS. 1A, 1B) has at least one movable first component 20 (see FIGS. 1A, 1B) and a second component 22 (see FIGS. 1A, 1B) coupled to the at least one movable first component 20. The wind tunnel model 16 is preferably an aircraft wind tunnel model 18 (see FIGS. 1A, 2B). The at least one movable first component 20 may comprise a leading edge device 24 (see FIGS. 1A, 5) or a trailing edge device 26

(see FIGS. 1A, 7) coupled to a wing **30** of the aircraft wind tunnel model **18**. The second component **22** may comprise the wing **30** (see FIGS. 1A, 2B) or a tail **32** (see FIGS. 1A, 2B) of the aircraft wind tunnel model **18**.

The wind tunnel model positioning and measuring system **10** (see FIGS. 1A, 1B) comprises a positioning assembly **50** (see FIGS. 1A, 1B) and a measuring assembly **70** (see FIGS. 1A, 1B). It should be noted that the particulars relating to the disclosed embodiment of the wind tunnel model positioning and measuring system **10**, as described above, apply with equal force to the particulars of this disclosed embodiment for the method **200**.

As shown in FIGS. 1A, 1B, the measuring assembly **70** comprises an automated movable structure **72** (see FIGS. 1A, 1B, 2E) with at least one measuring device **86** mounted thereon and configured for placement within the wind tunnel **12**. The automated movable structure **72** comprises a traversing arm structure **80** (see FIGS. 1A, 1B, 2D), such as a robotic traversing arm structure, or other type of automated traversing structure. The automated movable structure **72** is preferably operated or powered by a power source **82** (see FIGS. 1A, 1B, 2D), such as an electric motor **84** (see FIG. 1A), or another power source **82**, such as a hydraulic power source (not shown) or a pneumatic power source (not shown). The automated movable structure **72** further has at least one measuring device **86** (see FIGS. 1A, 1B, 2D, 2E) mounted thereon, preferably at the second end **76** (see FIGS. 2D, 2E). The at least one measuring device **86** preferably comprises a laser device **88** (see FIGS. 1A, 2E), an optical camera **90** (see FIG. 1A), a digital camera **92** (see FIG. 1A), a profilometer **93** (a measuring instrument used to measure a surface's profile in order to quantify its roughness),

or another contact or non-contact device capable of obtaining contour measurements of a surface, or another suitable measuring device **86**.

As further shown in FIGS. **1A**, **1B**, the measuring assembly **70** comprises a measuring controller device **100** configured for placement outside the wind tunnel **12**. The measuring controller device **100** is coupled to the power source **82** of the automated movable structure **72** and is used to operate or control the power source **82** and the automated movable structure **72** in order to remotely move the automated movable structure **72** from the storage position **96** (see FIG. **2C**) within the wind tunnel **12**, such as within a closet portion **94** (see FIGS. **1A**, **1B**) to the one or more operating positions **98** (see FIG. **2D**) with respect to the wind tunnel model **16** and to allow the at least one measuring device **86** to determine the relative position **68** (see FIG. **1A**) of the at least one movable first component **20** to the second component **22**.

As shown in FIGS. **1A**, **1B**, and as discussed in detail above, the positioning assembly **50** comprises at least one automated actuating element **52** (see FIGS. **1A**, **1B**) operable for coupling to the at least one movable first component **20** (see FIGS. **1A**, **1B**) in order to actuate or move the at least one movable first component **20**. The at least one automated actuating element **52** preferably comprises an actuator **54** (see FIGS. **1A**, **1B**) or other suitable device for moving the at least one movable first component **20**. The at least one automated actuating element **52** is preferably operated or powered by a power source **56** (see FIGS. **1A**, **1B**), such as an electric motor **58** (see FIG. **1A**), or another power source **56** such as a hydraulic power source (not shown) or a pneumatic power source (not shown).

As further shown in FIGS. 1A, 1B, the positioning assembly **50** comprises a positioning controller device **60** configured to be located outside the wind tunnel **12**. The positioning controller device **60** is operable for coupling to the at least one automated actuating element **52**, as discussed in detail above, in order to operate or control the at least one automated actuating element **52**.

As further shown in FIGS. 1A, 1B, the wind tunnel model positioning and measuring system **10** may further comprise a processing device **110**, such as a computer **112**, located outside the wind tunnel **12**. The processing device **110**, such as a computer **112**, preferably processes an output **114** (see FIGS. 1A, 1C) of relational measurements **116** (see FIGS. 1A, 1C) of the at least one movable first component **20** to the second component **22** as measured and obtained by the at least one measuring device **86**.

As shown in FIG. 8, the method **200** further comprises step **204** of adjusting with the positioning assembly **50** a relative position **68** (see FIGS. 1A, 2E, 2F) of the at least one movable first component **20** (see FIGS. 1A, 2E, 2F) with respect to the second component **22** (see FIGS. 1A, 2E, 2F). The step **204** of adjusting with the positioning assembly **50** further comprises operating at least one automated actuating element **52** (see FIG. 1A) coupled to the at least one movable first component **20** (see FIG. 1A) via a positioning controller device **60** (see FIG. 1A) configured to be located and placed outside the wind tunnel **12**. The step **204** of adjusting with the positioning assembly **50** further comprises controlling operation of the positioning assembly **50** using a computer **112** (see FIG. 1A) configured for placement and location outside the wind tunnel **12** and coupled to the positioning controller device **60**. The

step **204** of adjusting with the positioning assembly **50** further comprises adjusting at least one of a leading edge device **24** (see FIG. 1A) and a trailing edge device **26** (see FIG. 1A) relative to a wing **30** (see FIG. 1A) of the aircraft wind tunnel model **18** (see FIG. 1A).

The method **200** further comprises step **206** of moving within the wind tunnel **12** that is pressurized the automated movable structure **72** with the at least one measuring device **86**, from a storage position **96** (see FIGS. 1A, 2C) that does not influence an air flow **34** (see FIGS. 1A, 1B) across the wind tunnel model **16**, to one or more operating positions **98** (see FIGS. 1A, 2D) with respect to the wind tunnel model **16**. The positioning controller device **60** is used to remotely adjust a relative position **68** (see FIGS. 1A, 2E) of the at least one movable first component **20** to the second component **22** of the wind tunnel model **16**, such as in the form of the aircraft wind tunnel model **18**. The step **206** of moving within the wind tunnel **12** comprising moving a traversing arm structure **80** (see FIG. 1A) using an electric motor **84** (see FIG. 1A).

The automated movable structure **72** may be stored in the closet portion **94** (see FIGS. 1A, 1B) of the wind tunnel **12** or stored in another enclosed portion of the wind tunnel **12**. When not in operation, the automated movable structure **72** is preferably stored in the closet portion **94** in a storage position **96** (see FIGS. 1A, 2C) and does not influence the air flow **34** (see FIG. 1B) across the wind tunnel model **16**. When in operation, the automated movable structure **72** moves from the storage position **96** to one or more operating positions **98** (see FIGS. 1A, 2D, 2F), for example, operating position **98a** (see FIG. 2E) or operating position **98b** (see FIG. 2F).

The method **200** further comprises step **208** of measuring and verifying with the at least one measuring device **86** (see FIGS. **1A**, **2D**, **2E**) the relative position **68** (see FIGS. **2E**, **2F**) of the at least one movable first component **20** with respect to the second component **22**. The step **208** of measuring and verifying with the at least one measuring device **86** comprises preferably measuring a two-dimensional section **108** (see FIGS. **1A**, **2E**, **2F**) of the relative position **68** (see FIGS. **1A**, **2E**, **2F**) of the at least one movable first component **20** (see FIGS. **1A**, **2E**, **2F**) with respect to the second component **22**(see FIGS. **1A**, **2E**, **2F**) without depressurization of the wind tunnel **12**. The step **208** of measuring and verifying further comprises measuring and verifying using at least one of a laser **88** (see FIG. **1A**), an optical camera **90** (see FIG. **1A**), a digital camera **92** (see FIG. **1A**), a profilometer **93** (a measuring instrument used to measure a surface's profile in order to quantify its roughness), or another contact or non-contact device capable of obtaining contour measurements of a surface, or another suitable measuring device **86**.

The method **200** may further comprise optional step **210** of obtaining with the at least one measuring device **86** an output **114** (see FIGS. **1A**,**1C**) of relational measurements **116** (see FIGS. **1A**, **1C**) of the at least one movable first component **20** with respect to the second component **22**. The step **210** of obtaining with the at least one measuring device **86** an output **114** (see FIGS. **1A**,**1C**) of relational measurements **116** may comprise receiving at least one of a leading edge gap measurement **118** between a trailing edge point **126** of a leading edge device **24** and a forward edge **128** of a wing **30**, a leading edge height measurement **120** between the trailing edge point **126** of the leading edge device **24** and a flat reference surface **132** of the wing **30**, a leading edge angle measurement **122** between a flat

reference surface **136** of a leading edge device **24** and a flat reference surface **138** of the wing **30**, a trailing edge gap measurement between an upper leading edge point of a trailing edge device and a trailing edge point of the wing, and an overlap measurement between the upper leading edge point of the trailing edge device and a lower leading edge point of the trailing edge device.

The method **200** may further comprise optional step **212** of processing the output **114** of relational measurements **116** with a processing device **110** (see FIGS. **1A**, **1B**), such as a computer **112** (see FIGS. **1A**, **1B**).

Disclosed embodiments of the wind tunnel model positioning and measuring system **10** (see FIGS. **1A**, **1B**), wind tunnel model measuring system **11** (see FIGS. **1A**, **1B**), and the method **200** for positioning and measuring wind tunnel model components within a wind tunnel **12** (see FIGS. **1A**, **1B**) offer numerous advantages. They provide an automated movable structure **72** (see FIGS. **1A**, **2C**) with a measuring device **86** (see FIGS. **1A**, **2D**) mounted thereon that is movable from a storage position **96** (see FIGS. **1A**, **2C**) within a wind tunnel **12** (see FIGS. **1A**, **1B**), where it does not influence an air flow **34** (see FIGS. **1A**, **1B**) across a wind tunnel model **16** (see FIGS. **1A**, **1B**), to one or more operating positions **98** (see FIGS. **1A**, **2D**) that allow the measuring device **86** to determine a relative position **68** (see FIGS. **1A**, **2E**) of various components of the wind tunnel model **16**, such as a leading edge device **24** (see FIGS. **1A**, **2F**) to a wing **30** (see FIGS. **1A**, **2F**) or a trailing edge device **26** (see FIGS. **1A**, **2E**) to a wing **30** during a wind tunnel test. Disclosed embodiments of the wind tunnel model positioning and measuring system **10** (see FIGS. **1A**, **1B**), wind tunnel

model measuring system **11** (see FIGS. **1A**, **1B**), and the method **200** for positioning and measuring wind tunnel model components within a wind tunnel **12** (see FIGS. **1A**, **1B**) further provide in one embodiment a traversing arm structure **80** (see FIGS. **1A**, **2E**) with a laser device **88** (see FIGS. **1A**, **2E**) which measures a two-dimensional section **108** (see FIGS. **1A**, **2E**) of the wind tunnel model components, such as the leading edge device **24** (see FIGS. **1A**, **2F**) to the wing **30** (see FIGS. **1A**, **2F**) or the trailing edge device **26** (see FIGS. **1A**, **2E**) to the wing **30** without depressurization of the wind tunnel **12**. Thus, disclosed embodiments of the wind tunnel model positioning and measuring system **10** (see FIGS. **1A**, **1B**), the wind tunnel model measuring system **11** (see FIGS. **1A**, **1B**), and the method **200** for positioning and measuring wind tunnel model components within a wind tunnel **12** (see FIGS. **1A**, **1B**) allow automated electronic measurement of the wind tunnel model components, while allowing the wind tunnel **12** to remain pressurized and running.

In addition, disclosed embodiments of the wind tunnel model positioning and measuring system **10** (see FIGS. **1A**, **1B**), wind tunnel model measuring system **11** (see FIGS. **1A**, **1B**), and the method **200** for positioning and measuring wind tunnel model components within a wind tunnel **12** (see FIGS. **1A**, **1B**) avoid the use of manual tooling, manual placement on the wind tunnel model **16** of numerous electronic or automated devices with internal circuitry in each device, and manually recorded documentation, which in turn, may reduce wind tunnel test time and may thus reduce costs of testing. Moreover, by eliminating the use of known electronic or automated devices with internal circuitry, which can be costly and complicated to fit within the wind tunnel model **16**, with the wind tunnel model positioning and measuring system **10**, the wind tunnel model measuring system **11**

(see FIGS. 1A, 1B), and the method 200, only one measurement system is needed and thus wind tunnel testing time and down time are reduced and overall costs of testing may be reduced. In addition, disclosed embodiments of the wind tunnel model positioning and measuring system 10, the wind tunnel model measuring system 11 (see FIGS. 1A, 1B), and the method 200 minimize or eliminate tool misuse, incorrect recorded measurements, and failure to record measurements, which may improve the accuracy in measuring the relational measurements 116 (see FIG. 1A) of the wind tunnel model 16, and which may, in turn, result in improved reliability and efficiency in testing.

Because the wind tunnel model positioning and measuring system 10, the wind tunnel model measuring system 11 (see FIGS. 1A, 1B), and method 200 do not require costly and complex devices or equipment to be manually attached to the wind tunnel model 16, do not incur a lot of down time during wind tunnel testing, and do not require manual recordation of measurements, such systems 10, 11 and method 200 may ensure that wind tunnel testing may be conducted less expensively, more quickly, and more accurately. Thus, such systems 10, 11 and method 200 provide an automated measuring assembly for measuring and verifying relational measurements of the various components of the wind tunnel model, provide an automated positioning assembly for positioning the various components of the wind tunnel model 16, and provide a processing device for easily and quickly processing the recorded measurements of the wind tunnel model.

In the figures and the text, in one aspect, a wind tunnel model measuring system 11 is disclosed for use with a wind tunnel 12, the system 11 comprising: a measuring

assembly **70** comprising: an automated movable structure **72** with at least one measuring device **86** mounted thereon and configured for placement within the wind tunnel **12**; and, a measuring controller device **100** located outside the wind tunnel **12** to control the automated movable structure **72** in order to remotely move the automated movable structure **72** from a storage position within the wind tunnel **12** to one or more operating positions with respect to a wind tunnel model **16** within the wind tunnel **12** and to allow the at least one measuring device **86** to determine a relative position of at least one movable first component **20** of the wind tunnel model **16** with respect to a second component **22** of the wind tunnel model **16**; and, a processing device **110** configured for placement outside the wind tunnel **12** and coupled to the measuring controller device **100**.

In one variant, the wind tunnel model **16** measuring system further includes a positioning assembly **50** comprising: at least one automated actuating element **52** operable for coupling to the at least one movable first component **20** of the wind tunnel model **12**; and, a positioning controller device **60** configured to be located outside the wind tunnel **12** and further configured to control the at least one automated actuating element **52** in order to remotely adjust the relative position of the at least one movable first component **20** with respect to the second component **22** of the wind tunnel **12**. In another variant, the wind tunnel model measuring system **11** includes wherein the wind tunnel model **16** is an aircraft wind tunnel model **18**, and further wherein the at least one movable first component **20** is a leading edge device **24** coupled to a wing **30** of the aircraft wind tunnel model **18** and the second component **22** is the wing of the aircraft wind tunnel model **18**. In yet another variant, the wind tunnel model measuring system **11** includes wherein the processing device **110**

comprises a computer **112** that processes an output of relational measurements comprising at least one of a leading edge gap measurement **118** between a trailing edge point **126** of the leading edge device **24** and a forward edge **128** of the wing **30**, a leading edge height measurement **120** between the trailing edge point **126** of the leading edge device **24** and a flat reference surface **132** of the wing **30**, and a leading edge angle measurement **122** between a flat reference surface **136** of the leading edge device **24** and a flat reference surface **138** of the wing **30**.

In one instance of the wind tunnel model measuring system **11**, the wind tunnel model **16** is an aircraft wind tunnel model **18**, and the at least one movable first component **20** is a trailing edge device **26** coupled to a wing **30** of the aircraft wind tunnel model **18** and the second component **22** is the wing **30** of the aircraft wind tunnel model **18**. In another instance, the wind tunnel model measuring system **11** includes wherein the processing device **110** comprises a computer **112** that processes an output of relational measurements comprising at least one of a trailing edge gap measurement **140** between an upper leading edge point **146** of the trailing edge device **26** and a trailing edge point of a spoiler of the wing **30**, and a trailing edge overlap measurement **142** between the upper leading edge point **146** of the trailing edge device **26** and a lower leading edge point **154** of the trailing edge device **26** and between the trailing edge point **148** of the spoiler **48** of the wing **30** and a spoiler portion **156** of the wing **30**.

In yet another instance, the wind tunnel model measuring system **11** includes wherein the at least one measuring device **86** comprises at least one of a laser, an optical

camera, a digital camera, and a profilometer, the at least one measuring device **86** operable to measure a two-dimensional section **108** of the relative position of the at least one movable first component **20** with respect to the second component **22**. In one example, the wind tunnel model measuring system **11** includes wherein the automated movable structure **72** comprises a traversing arm structure **80** operable from the storage position **96** within the wind tunnel **12**, the storage position **96** configured such that the traversing arm structure **80** does not influence an air flow across the wind tunnel model **16**.

In one aspect, a wind tunnel **12** is disclosed incorporating a wind tunnel model measuring system **11**, the wind tunnel **12** including: a plurality of walls **170** defining a wind tunnel structure **172**, and at least one of the plurality of walls **170** defining a closet portion; a motorized fan **174** mounted within a fan portion of the wind tunnel structure **172**; a wind tunnel model measuring system **11** having a measuring assembly **70**, the measuring assembly **70** comprising: an automated movable structure **72** with at least one measuring device **86** mounted thereon and configured for placement within the wind tunnel **12**; and, a measuring controller device **100** located outside the wind tunnel **12** to control the automated movable structure **72** in order to remotely move the automated movable structure **72** from a storage position **96** within the closet portion **94** of the wind tunnel **12** to one or more operating positions with respect to a wind tunnel model **16** within the wind tunnel **12** and to allow the at least one measuring device **86** to determine a relative position of at least one movable first component **20** of the wind tunnel model **16** with respect to a second component **22** of the wind tunnel model **16**, the second component coupled to the at least one movable first component **20**; and, a computer **112** configured for placement outside the wind tunnel **12** and

coupled to the measuring controller device **100** to process an output of relational measurements obtained by the at least one measuring device **86** of the at least one movable first component **20** with respect to the second component **22**.

In one variant, the wind tunnel **12** further includes a positioning assembly comprising: at least one automated actuating element **52** operable for coupling to the at least one movable first component **20** of the wind tunnel model **16**; and, a positioning controller device **60** configured to be located outside the wind tunnel **12** and further configured to control the at least one automated actuating element **52** in order to remotely adjust the relative position of the at least one movable first component **20** with respect to the second component **22** of the wind tunnel model **16**, the computer **112** coupled to the positioning controller device **60** to effect the remote adjustment. In another variant, the wind tunnel **12** includes wherein the wind tunnel model **16** is an aircraft wind tunnel model **18**, and further wherein the at least one movable first component **20** is a leading edge device **24** coupled to a wing **30** of the aircraft wind tunnel model **18** and the second component **22** is the wing **30** of the aircraft wind tunnel model **18**. In yet another variant, the wind tunnel **12** includes wherein the output of relational measurements comprises at least one of a leading edge gap measurement between a trailing edge point **148** of the leading edge device **24** and a forward edge of the wing, a leading edge height measurement **120** between the trailing edge point **148** of the leading edge device **24** and a flat reference surface of the wing, and a leading edge angle measurement between a flat reference surface of the leading edge device **24** and a flat reference surface of the wing.

In one instance, the wind tunnel **12** includes wherein the wind tunnel model **16** is an aircraft wind tunnel model **18**, and further wherein the at least one movable first component **20** is a trailing edge device **26** coupled to a wing of an aircraft wind tunnel model **18** and the second component **22** is the wing of the aircraft wind tunnel model **18**. In another instance, the wind tunnel **12** includes wherein the output of relational measurements comprises at least one of a trailing edge gap measurement **140** between an upper leading edge point **146** of the trailing edge device **26** and a trailing edge point **148** of a spoiler of the wing, and a trailing edge overlap measurement **142** between the upper leading edge point **146** of the trailing edge device **26** and a lower leading edge point **154** of the trailing edge device **26** and between the trailing edge point **148** of the spoiler of the wing and a spoiler portion of the wing. In yet another instance, the wind tunnel **12** includes wherein the automated movable structure **72** comprises a traversing arm structure **80** powered by an electric motor, the traversing arm structure **80** movable from the storage position **96** within the closet portion **94** to at least one measurement position within the wind tunnel **12**, the closet portion **94** and the storage position **96** configured such that the traversing arm structure **80** does not influence an air flow across the wind tunnel model **16**. In one example, the wind tunnel **12** includes wherein the at least one measuring device **86** comprises at least one of a laser, an optical camera, a digital camera, and a profilometer.

In one aspect, a method is disclosed for positioning and measuring wind tunnel model components within a pressurized wind tunnel **12**, the method includes: installing in a wind tunnel **12**, a wind tunnel model **16** and a wind tunnel model positioning and measuring system **10**, the wind tunnel model **16** having at least one movable first component **20** and a

second component **22** coupled to the at least one movable first component **20**, the wind tunnel model positioning and measuring system **10** comprising a positioning assembly **50** and a measuring assembly **70**, the measuring assembly **70** having an automated movable structure **72** with at least one measuring device **86** mounted thereon; adjusting with the positioning assembly a relative position of the at least one movable first component **20** with respect to the second component **22**; moving within a pressurized wind tunnel **12** the automated movable structure **72** with the at least one measuring device **86**, from a storage position **96** that does not influence an air flow across the wind tunnel model **16**, to one or more operating positions with respect to the wind tunnel model **16**; and, measuring and verifying with the at least one measuring device **86** the relative position of the at least one movable first component **20** with respect to the second component **22**.

In one variant, the method further includes obtaining with the at least one measuring device **86** an output of relational measurements of the at least one movable first component **20** with respect to the second component **22**, and processing the output of relational measurements with a computer **112**. In another variant, the method includes wherein obtaining with the at least one measuring device **86** comprises receiving at least one of a leading edge gap measurement **118** between a trailing edge point **126** of a leading edge device **24** and a forward edge **128** of a wing **30**, a leading edge height measurement **120** between the trailing edge point **126** of the leading edge device **24** and a flat reference surface **132** of the wing **30**, a leading edge angle measurement **122** between a flat reference surface **136** of a leading edge device **24** and a flat reference surface **138** of the wing **30**, a trailing edge gap measurement **140** between an upper leading edge point **146** of a trailing edge device

26 and a trailing edge point **148** of a spoiler **48** of the wing **30**, and a trailing edge overlap measurement **142** between the upper leading edge point **146** of the trailing edge device **26** and a lower leading edge point **154** of the trailing edge device **26** and between the trailing edge point **148** of the spoiler **48** of the wing **30** and a spoiler portion **156** of the wing **30**.

5 In one instance, the method includes wherein adjusting with the positioning assembly comprises operating at least one automated actuating element **52** coupled to the at least one movable first component **20** via a positioning controller device **60** configured to be located outside the wind tunnel **12**. In another instance, the method includes wherein adjusting with the positioning assembly **50** comprises controlling operation of the positioning
10 assembly **50** using a computer **112** configured for placement outside the wind tunnel **12** and coupled to the positioning controller device **60**. In yet another instance, the method includes wherein the measuring and verifying with the at least one measuring device **86** comprises measuring a two-dimensional section of the relative position of the at least one movable first component **20** with respect to the second component **22** without depressurization of the wind
15 tunnel **12**. In yet another instance, the method includes wherein: moving within the pressurized wind tunnel **12** the automated movable structure **72** with the at least one measuring device **86** comprises moving a traversing arm structure **80** using an electric motor; and, measuring and verifying with the at least one measuring device **86** comprises measuring and verifying using at least one of a laser, an optical camera, a digital camera, and a
20 profilometer. In still yet another instance the method includes wherein adjusting with the positioning assembly comprises adjusting at least one of a leading edge device **24** and a

trailing edge device **26** relative to a wing of an aircraft wind tunnel model **18**.

Many modifications and other embodiments of the disclosure will come to mind to one skilled in the art to which this disclosure pertains having the benefit of the teachings presented in the foregoing descriptions and the associated drawings. The embodiments
5 described herein are meant to be illustrative and are not intended to be limiting or exhaustive. Although specific terms are employed herein, they are used in a generic and descriptive sense only and not for purposes of limitation.

THE SUBJECT-MATTER OF THE INVENTION FOR WHICH AN EXCLUSIVE PROPERTY OR PRIVILEGE IS CLAIMED IS DEFINED AS FOLLOWS:

1. A wind tunnel model measuring system for use with a wind tunnel, the system comprising:

5 a wind tunnel model configured for placement within the wind tunnel, the wind tunnel model comprising at least one first component and a second component, wherein the at least one first component of the wind tunnel model is movable with respect to the second component of the wind tunnel model;

a measuring assembly comprising:

10 an automated movable structure with at least one measuring device mounted thereon and configured for placement within the wind tunnel; and,

15 a measuring controller device located outside the wind tunnel to control the automated movable structure in order to remotely move the automated movable structure from a storage position within the wind tunnel to one or more operating positions with respect to the wind tunnel model when the wind tunnel model is within the wind tunnel and to allow the at least one measuring device to determine a relative position of the at least one movable first component of the wind tunnel model with respect to the second component of the wind tunnel model;

20 and,

a processing device configured for placement outside the wind tunnel and coupled to the measuring controller device.

2. The wind tunnel model measuring system of claim 1 further comprising a positioning assembly comprising:

at least one automated actuating element operable for coupling to the at least one movable first component of the wind tunnel model; and,

- 5 a positioning controller device configured to be located outside the wind tunnel and further configured to control the at least one automated actuating element in order to remotely adjust the relative position of the at least one movable first component with respect to the second component of the wind tunnel model.

- 10 3. The wind tunnel model measuring system of claim 1 or 2 wherein the processing device comprises a computer configured to process an output of relational measurements obtained by the at least one measuring device.

- 15 4. The wind tunnel model measuring system of claim 1 or 2 wherein the wind tunnel model is an aircraft wind tunnel model, and further wherein the at least one movable first component is a leading edge device coupled to a wing of the aircraft wind tunnel model and the second component is the wing of the aircraft wind tunnel model.

5. The wind tunnel model measuring system of claim 4 wherein the processing device comprises a computer configured to process an output of relational measurements obtained by the at least one measuring device, the output of relational measurements comprising

- 20 a leading edge gap measurement between a trailing edge point of the leading edge device and a forward edge of the wing,

a leading edge height measurement between the trailing edge point of the leading edge device and a flat reference surface of the wing, or

a leading edge angle measurement between a flat reference surface of the leading edge device and a flat reference surface of the wing, or

a combination of two or more thereof.

- 5 6. The wind tunnel model measuring system of claim 1 or 2 wherein the wind tunnel model is an aircraft wind tunnel model, and further wherein the at least one movable first component is a trailing edge device coupled to a wing of the aircraft wind tunnel model and the second component is the wing of the aircraft wind tunnel model.
- 10 7. The wind tunnel model measuring system of claim 6 wherein the processing device comprises a computer configured to process an output of relational measurements obtained by the at least one measuring device, the output of relational measurements comprising
- a trailing edge gap measurement between an upper leading edge point of the trailing edge device and a trailing edge point of a spoiler of the wing, or
- 15 a trailing edge overlap measurement between the upper leading edge point of the trailing edge device and a lower leading edge point of the trailing edge device and between the trailing edge point of the spoiler of the wing and a spoiler portion of the wing, or
- both the trailing edge gap measurement and the trailing edge overlap measurement.
- 20 8. The wind tunnel model measuring system of any one of claims 1 to 7 wherein the at least one measuring device comprises a laser, an optical camera, a digital camera, or a profilometer, a combination of two or more thereof.
9. The wind tunnel model measuring system of any one of claims 1 to 8 wherein the at least one measuring device is operable to measure a two-dimensional section of the

relative position of the at least one movable first component with respect to the second component.

10. The wind tunnel model measuring system of any one of claims 1 to 9 wherein the automated movable structure comprises a traversing arm structure.
- 5 11. The wind tunnel model measuring system of claim 10 wherein the traversing arm structure is powered by an electric motor.
12. The wind tunnel model measuring system of claim 10 or 11 wherein the traversing arm structure is configured to provide translation motion to the at least one measuring device.
- 10 13. The wind tunnel model measuring system of claim 10, 11, or 12 wherein the traversing arm structure is configured to provide rotary motion to the at least one measuring device.
14. The wind tunnel model measuring system of claim 10, 11, 12, or 13 wherein the traversing arm structure is operable from the storage position within the wind tunnel.
- 15 15. The wind tunnel model measuring system of any one of claim 14 wherein the storage position configured such that the traversing arm structure does not influence an air flow across the wind tunnel model.
- 20 16. The wind tunnel model measuring system of any one of claims 1 to 15 wherein the second component of the wind tunnel model is coupled to the at least one movable first component of the wind tunnel model.
17. The wind tunnel model measuring system of claim 16 wherein the second component of the wind tunnel model is hinged to the at least one movable first component of the wind tunnel model.

18. The wind tunnel model measuring system of any one of claims 1 to 15 wherein the second component of the wind tunnel model is coupled with a pivot to the at least one movable first component of the wind tunnel model.
19. A wind tunnel incorporating the wind tunnel model measuring system of any one of
5 claims 1 to 18, the wind tunnel comprising:
- a plurality of walls defining a wind tunnel structure of the wind tunnel, and at least one of the plurality of walls defining a closet portion, wherein the storage position is within the closet portion; and
- a motorized fan mounted within a fan portion of the wind tunnel structure.
- 10 20. A method for positioning and measuring wind tunnel model components within a pressurized wind tunnel, the wind tunnel comprising a wind tunnel model and a wind tunnel model positioning and measuring system in the wind tunnel, the wind tunnel model having at least one movable first component and a second component coupled to the at least one movable first component, the wind tunnel model positioning and
15 measuring system comprising a positioning assembly and a measuring assembly, the measuring assembly having an automated movable structure with at least one measuring device mounted thereon, the method comprising:
- adjusting with the positioning assembly a relative position of the at least one movable first component with respect to the second component;
- 20 moving within the pressurized wind tunnel the automated movable structure with the at least one measuring device, from a storage position that does not influence an air flow across the wind tunnel model, to one or more operating positions with respect to the wind tunnel model; and,

measuring and verifying with the at least one measuring device the relative position of the at least one movable first component with respect to the second component.

- 5 **21.** The method of claim **20** further comprising obtaining with the at least one measuring device an output of relational measurements of the at least one movable first component with respect to the second component, and processing the output of relational measurements with a computer.
- 22.** The method of claim **21** wherein obtaining with the at least one measuring device comprises receiving
- 10 a leading edge gap measurement between a trailing edge point of a leading edge device and a forward edge of a wing,
- a leading edge height measurement between the trailing edge point of the leading edge device and a flat reference surface of the wing,
- 15 a leading edge angle measurement between a flat reference surface of a leading edge device and a flat reference surface of the wing,
- a trailing edge gap measurement between an upper leading edge point of a trailing edge device and a trailing edge point of a spoiler of the wing, or
- a trailing edge overlap measurement between the upper leading edge point of the trailing edge device and a lower leading edge point of the trailing edge device and between the trailing edge point of the spoiler of the wing and a spoiler portion of the wing, or
- 20 a combination of two or more thereof.

23. The method of claim **20**, **21**, or **22** wherein adjusting with the positioning assembly comprises operating at least one automated actuating element coupled to the at least one movable first component via a positioning controller device configured to be located outside the wind tunnel.
- 5 24. The method of claim **23** wherein adjusting with the positioning assembly comprises controlling operation of the positioning assembly using a computer configured for placement outside the wind tunnel and coupled to the positioning controller device.
25. The method of claim **23** or **24** wherein adjusting with the positioning assembly comprises pivoting the at least one movable first component with respect to the second
10 component.
26. The method of any one of claims **20** to **25** wherein the measuring and verifying with the at least one measuring device comprises measuring a two-dimensional section of the relative position of the at least one movable first component with respect to the second component without depressurization of the wind tunnel.
- 15 27. The method of any one of claims **20** to **26** wherein moving within the pressurized wind tunnel the automated movable structure with the at least one measuring device comprises moving a traversing arm structure.
28. The method of claim **27** wherein moving the traversing arm structure comprises moving the traversing arm structure using an electric motor.
- 20 29. The method of any one of claims **20** to **28** wherein: measuring and verifying with the at least one measuring device comprises measuring and verifying using a laser, an optical camera, a digital camera, or a profilometer, or two or more thereof.
- 25 30. The method of any one of claims **20** to **29** wherein adjusting with the positioning assembly comprises adjusting of a leading edge device or a trailing edge device, or both, relative to a wing of an aircraft wind tunnel model.

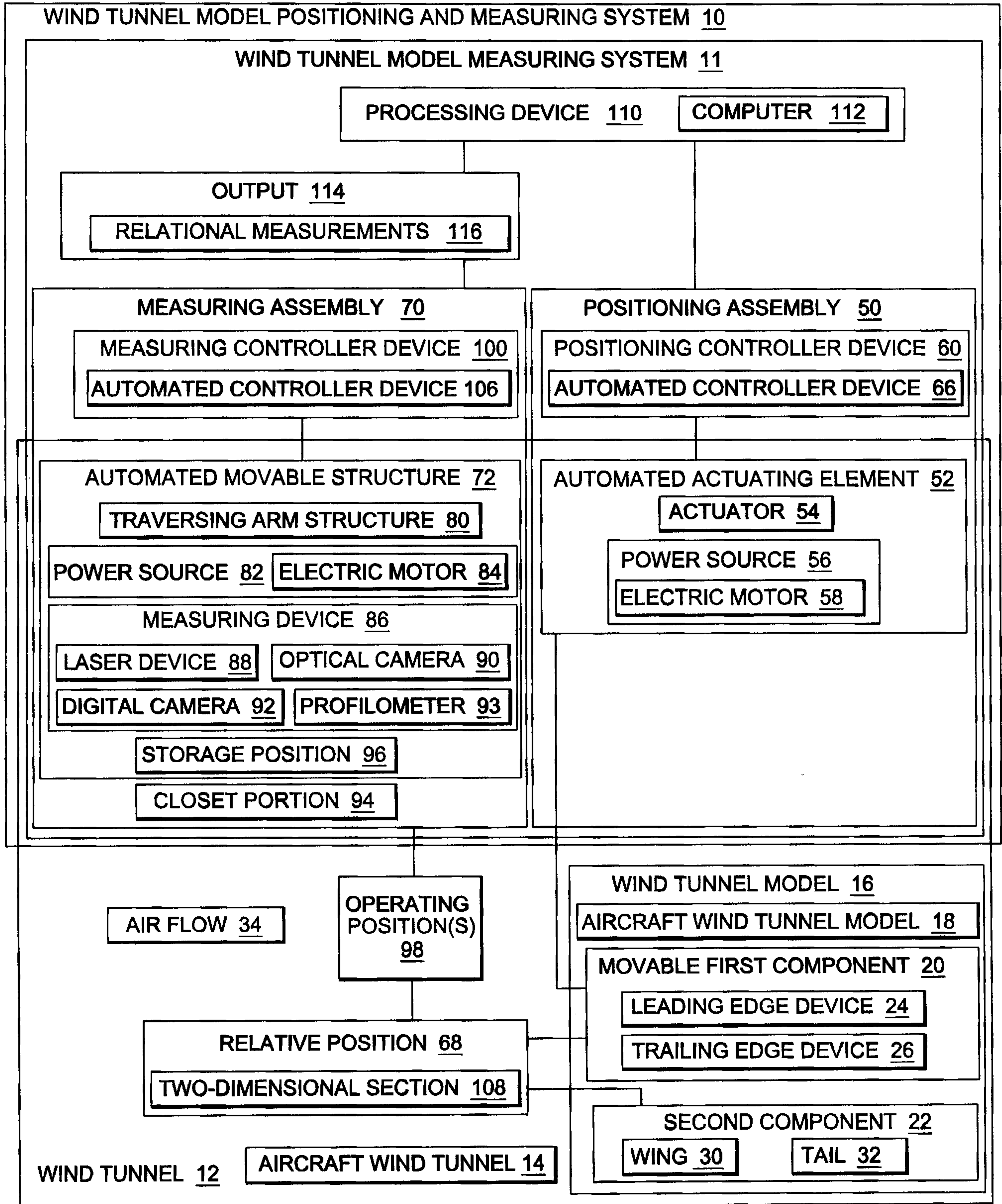

FIG. 1A

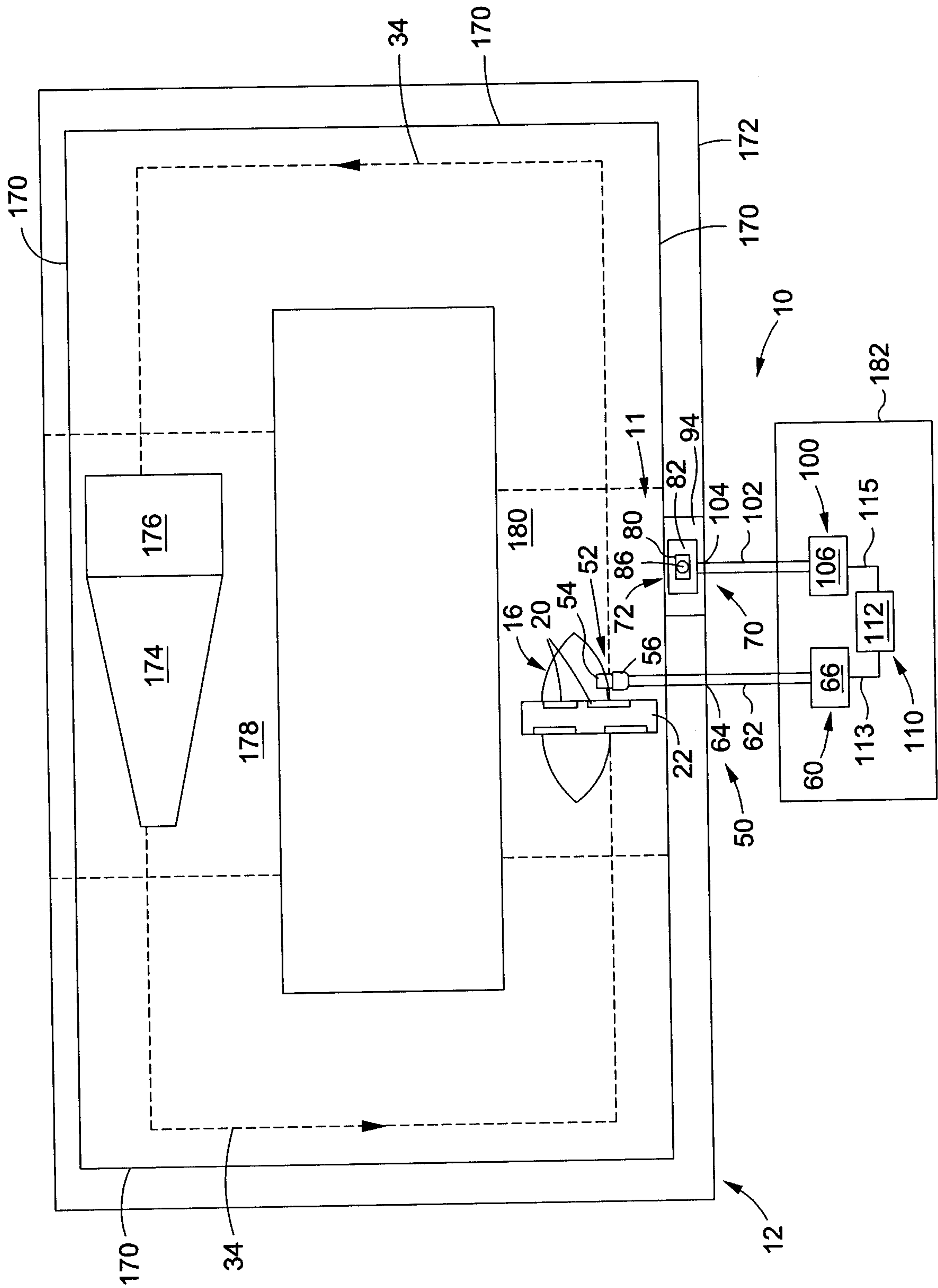

FIG. 1B

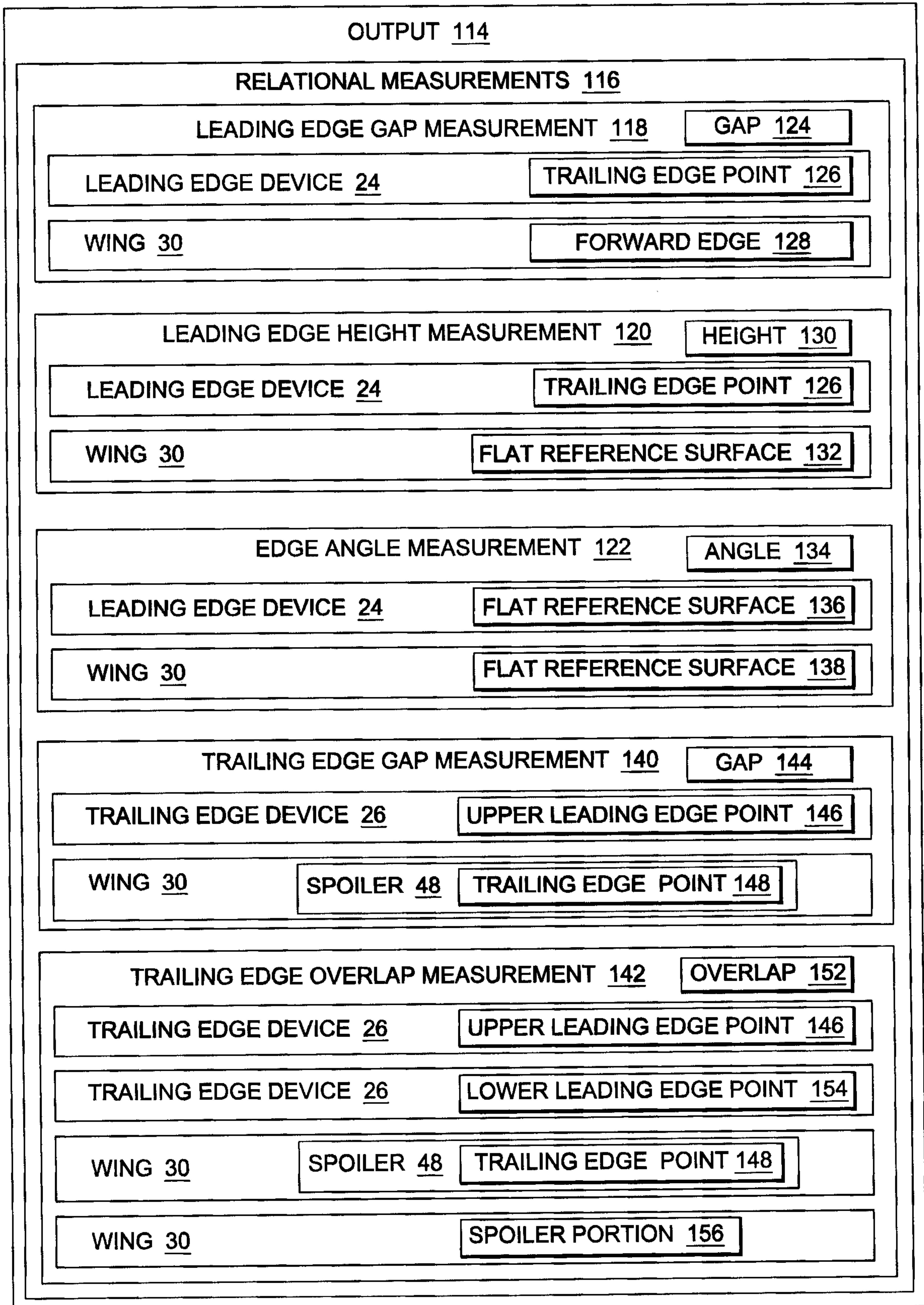
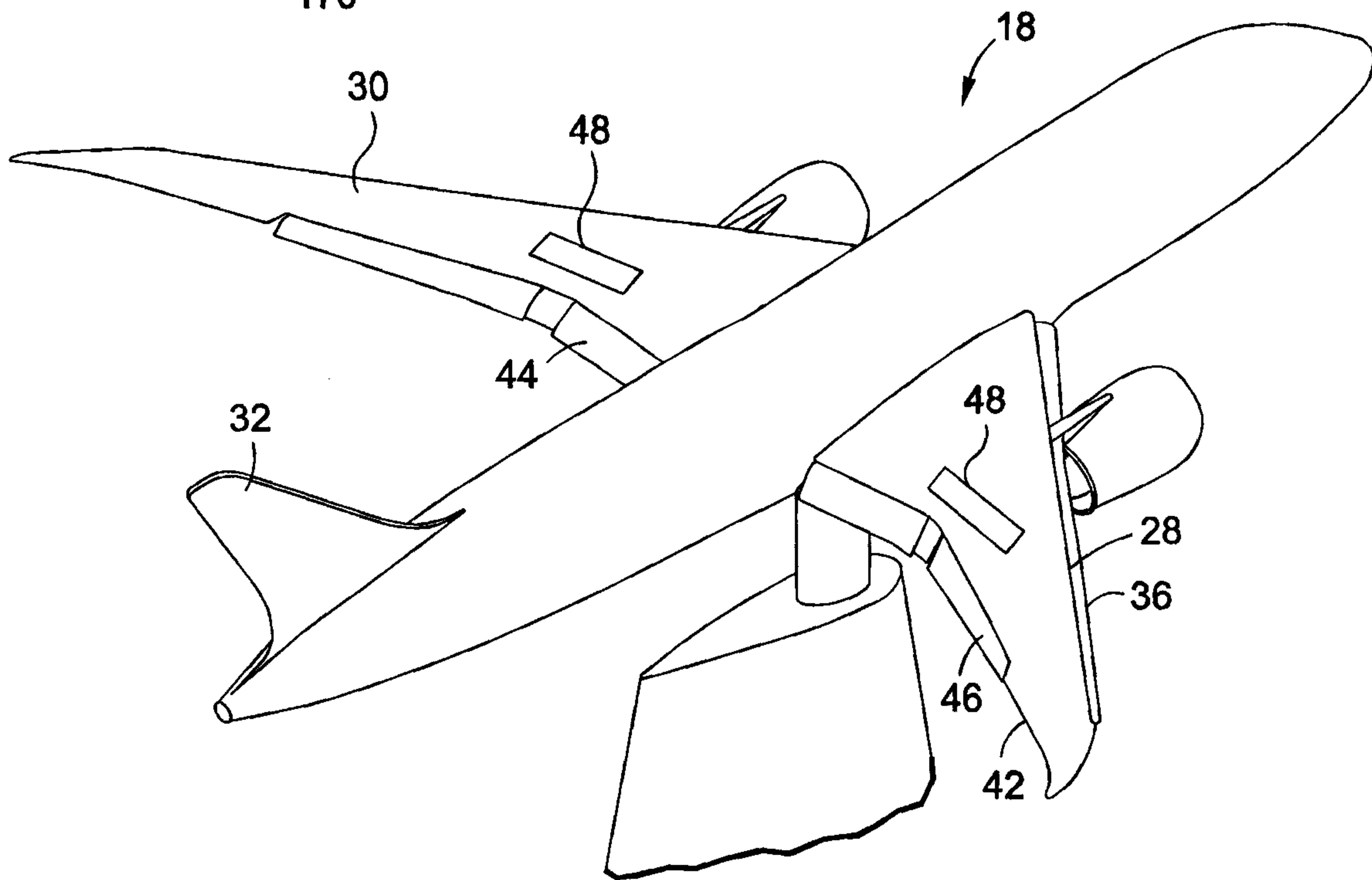
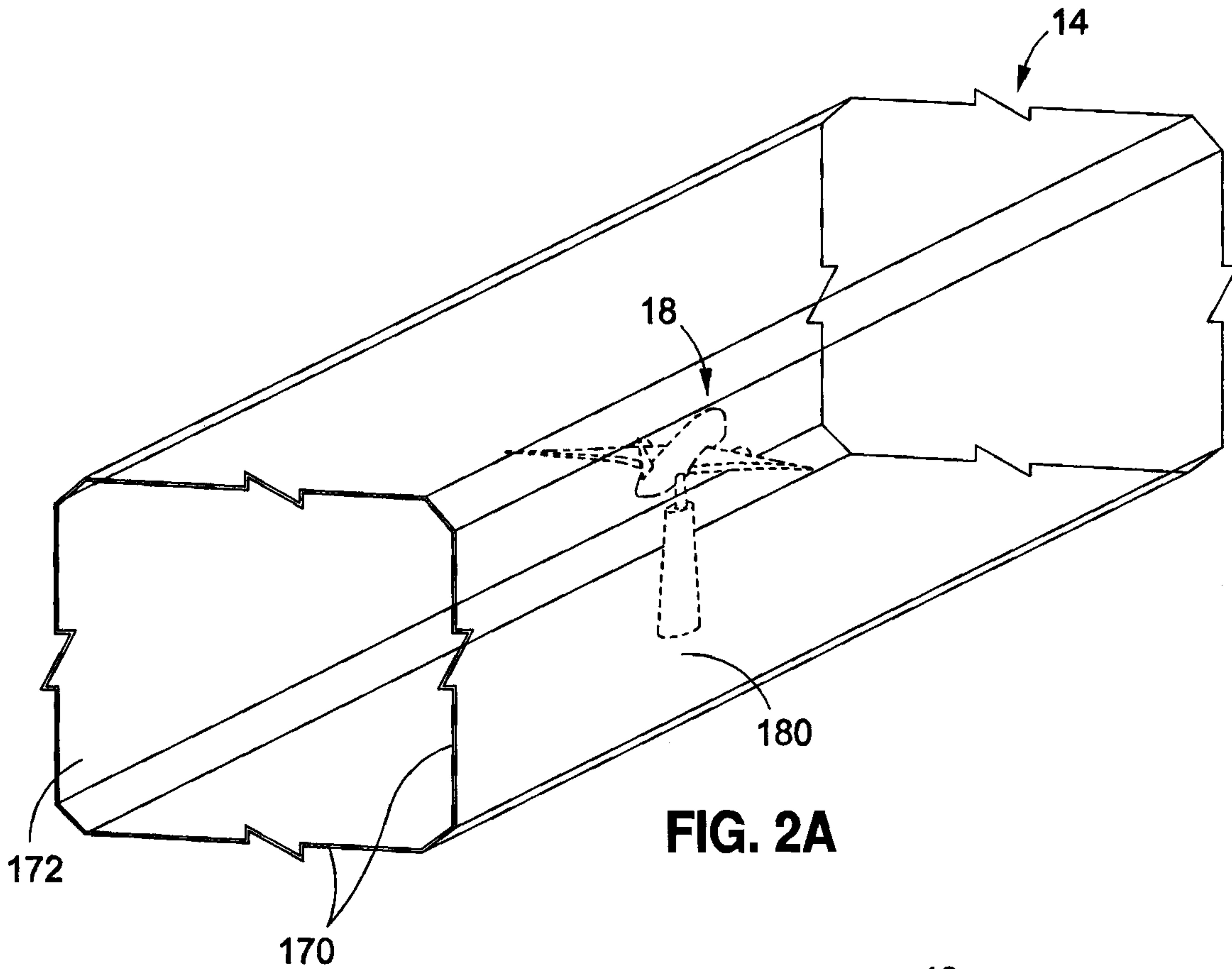
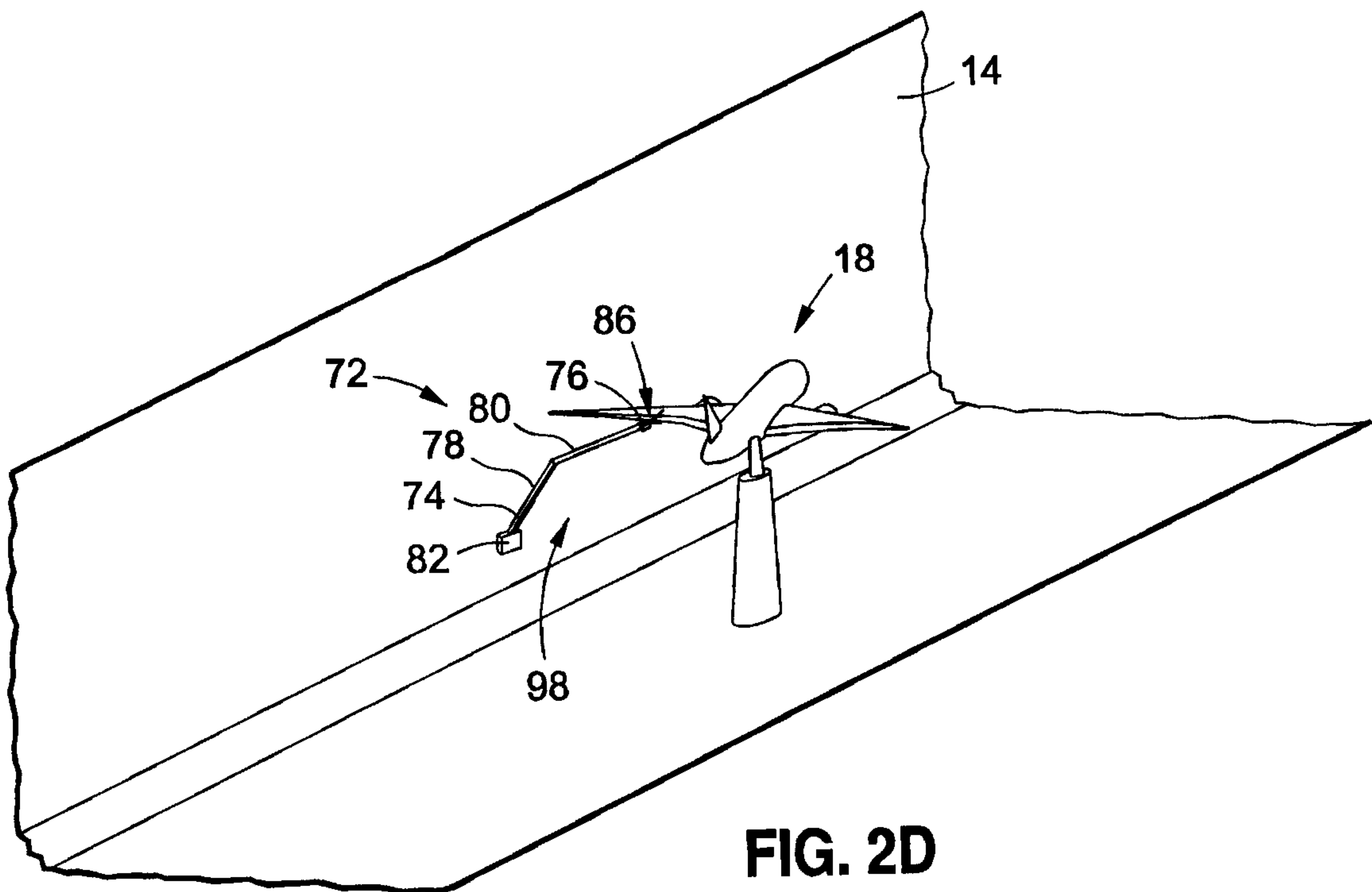
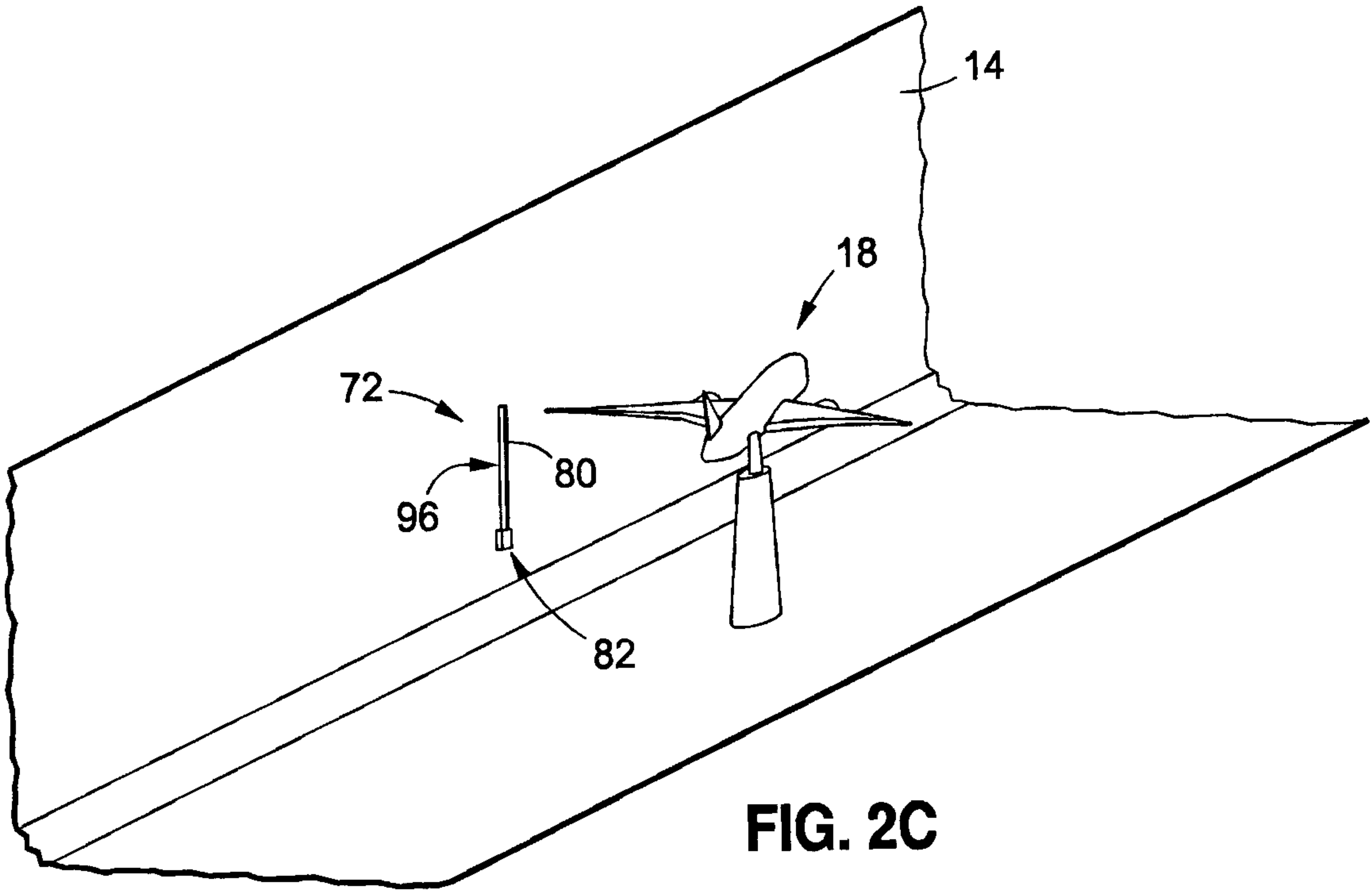

FIG. 1C

4/11



5/11



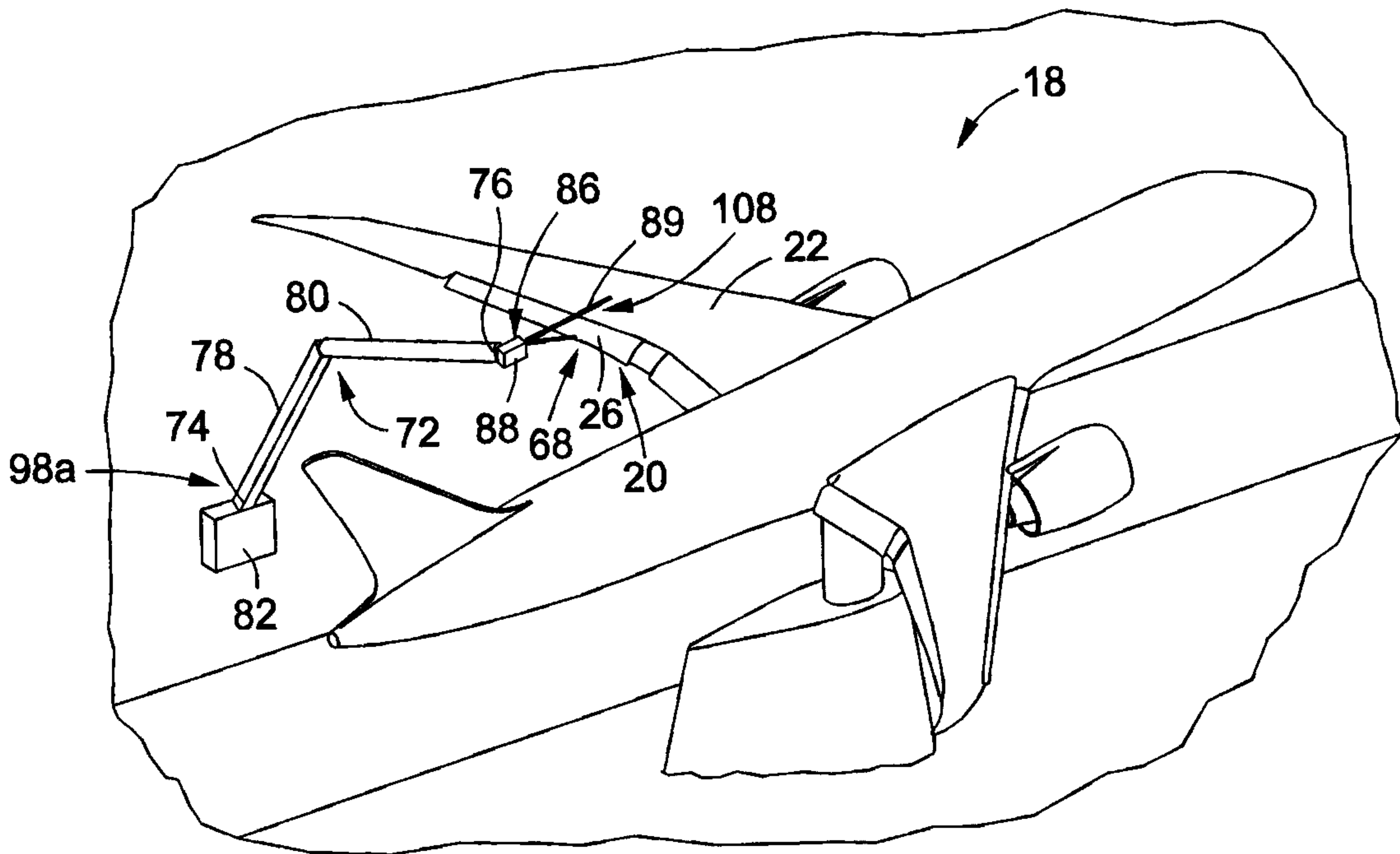

FIG. 2E

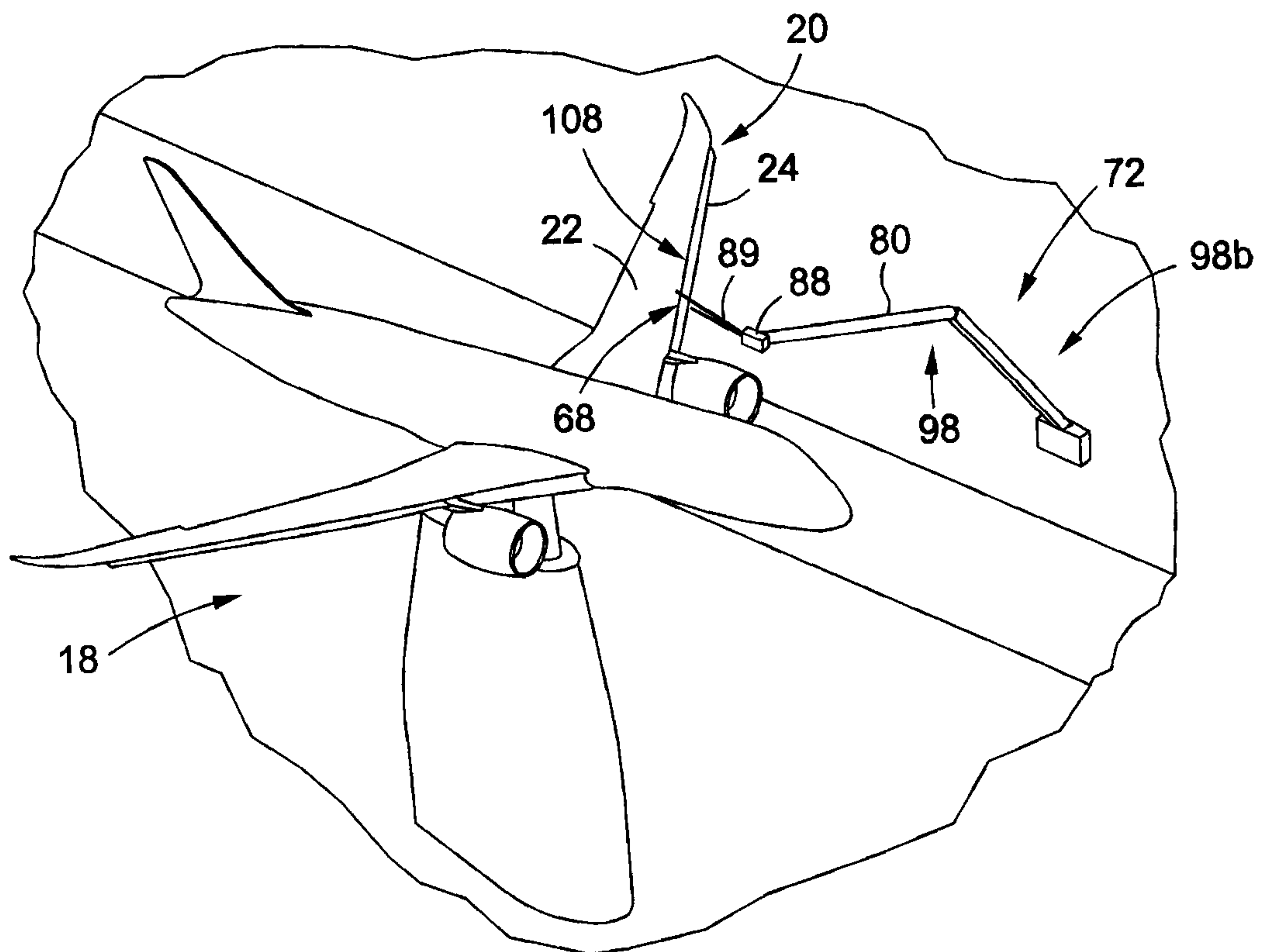

FIG. 2F

7/11

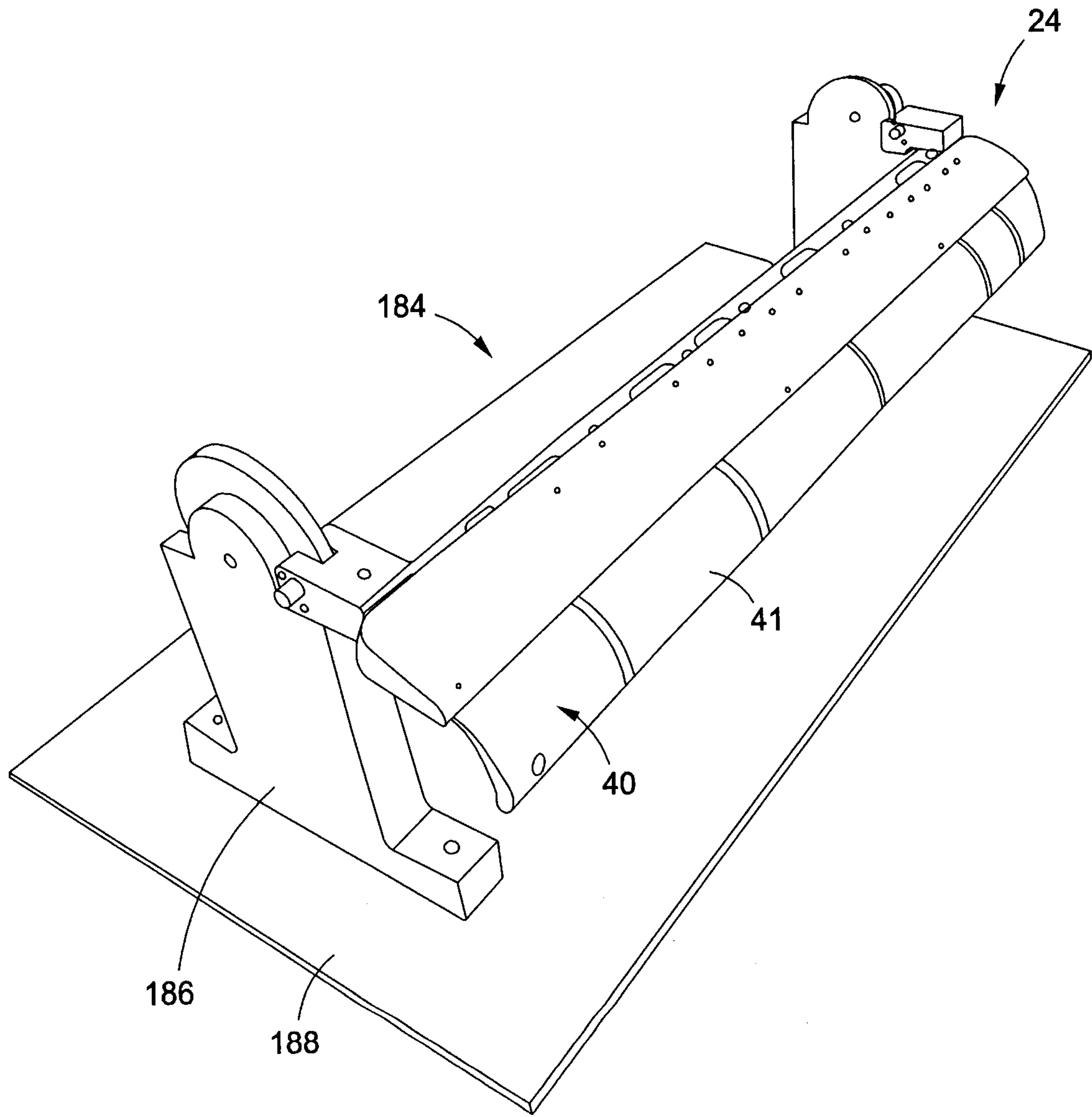

FIG. 3

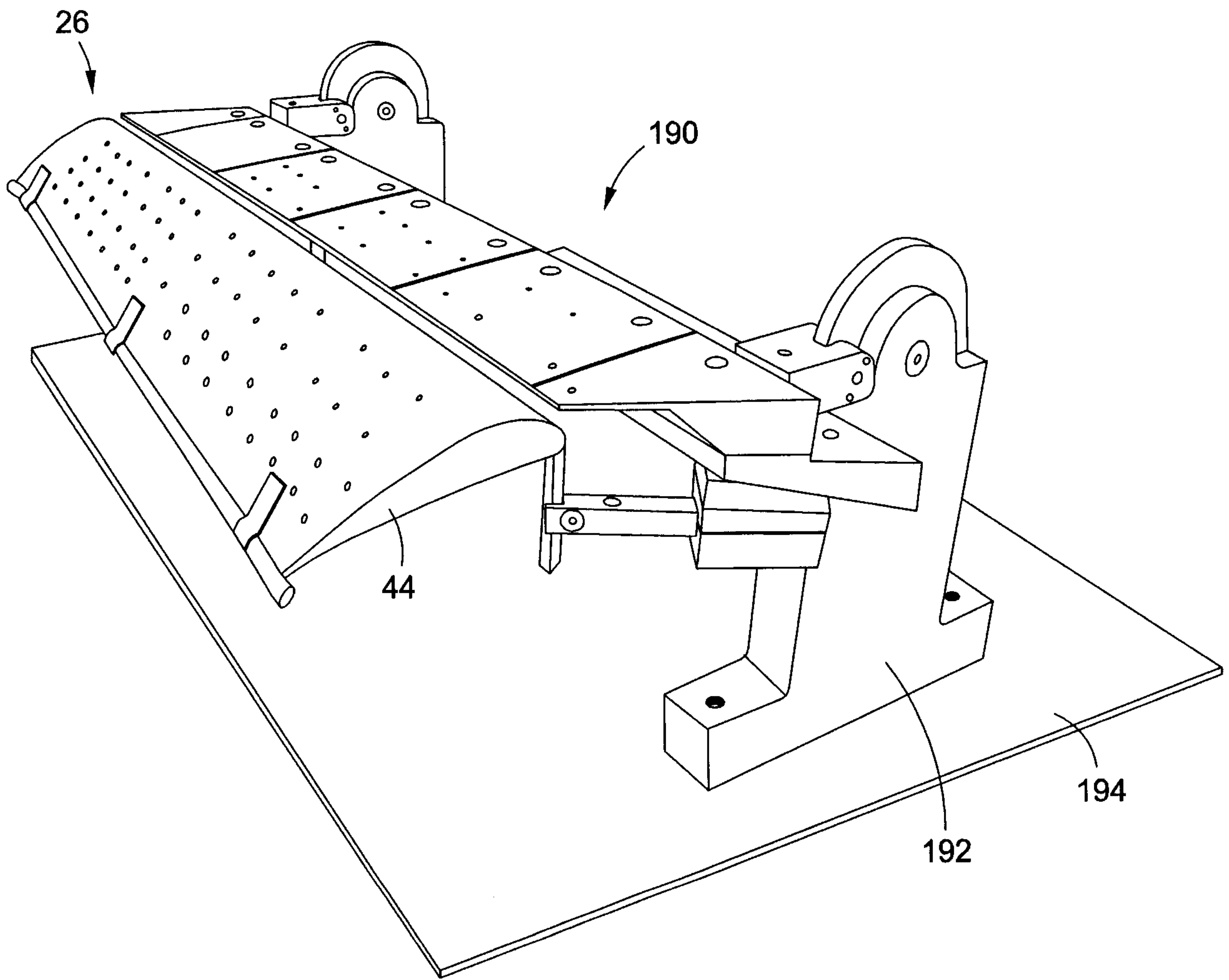

FIG. 4

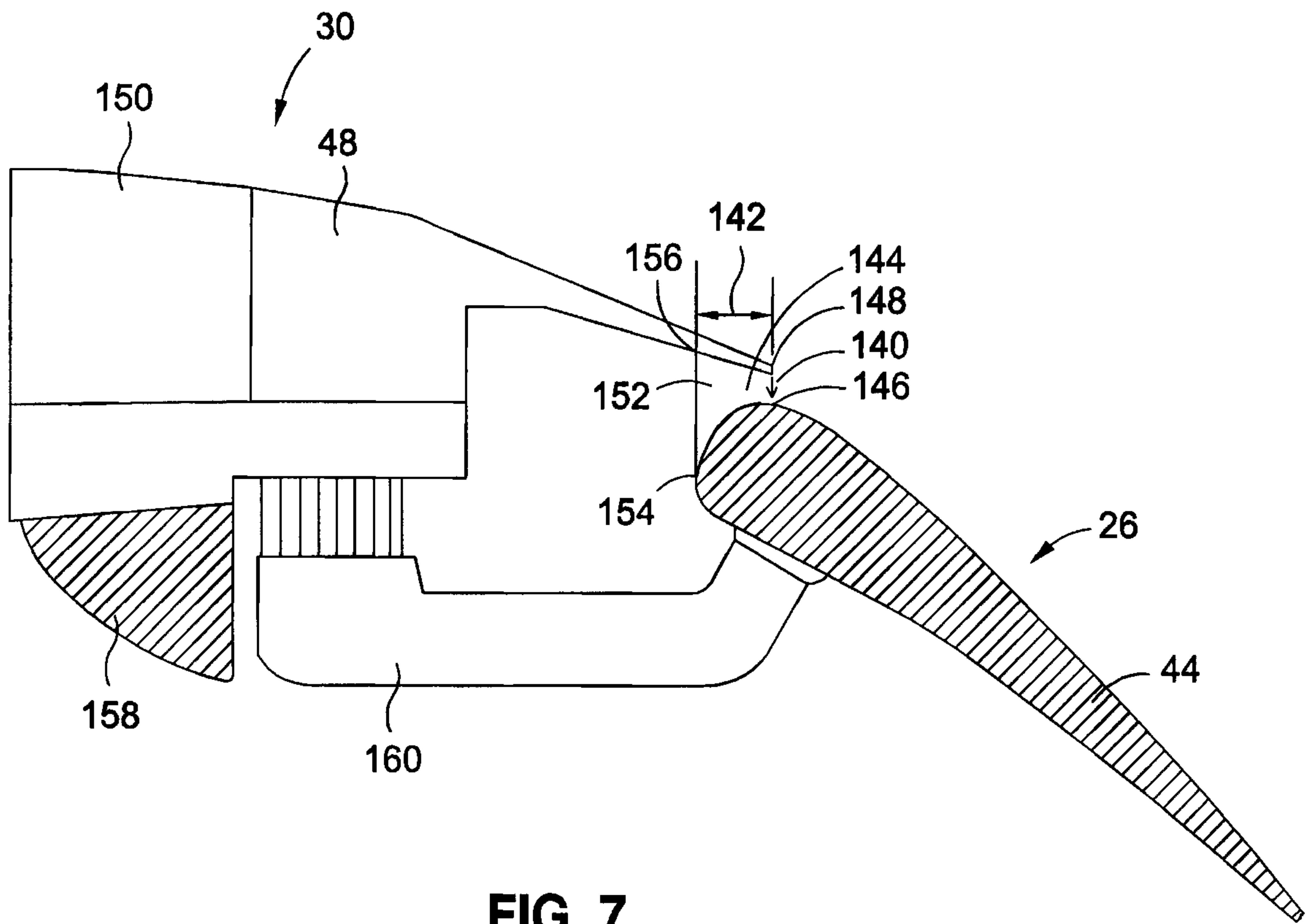

FIG. 7

11/11

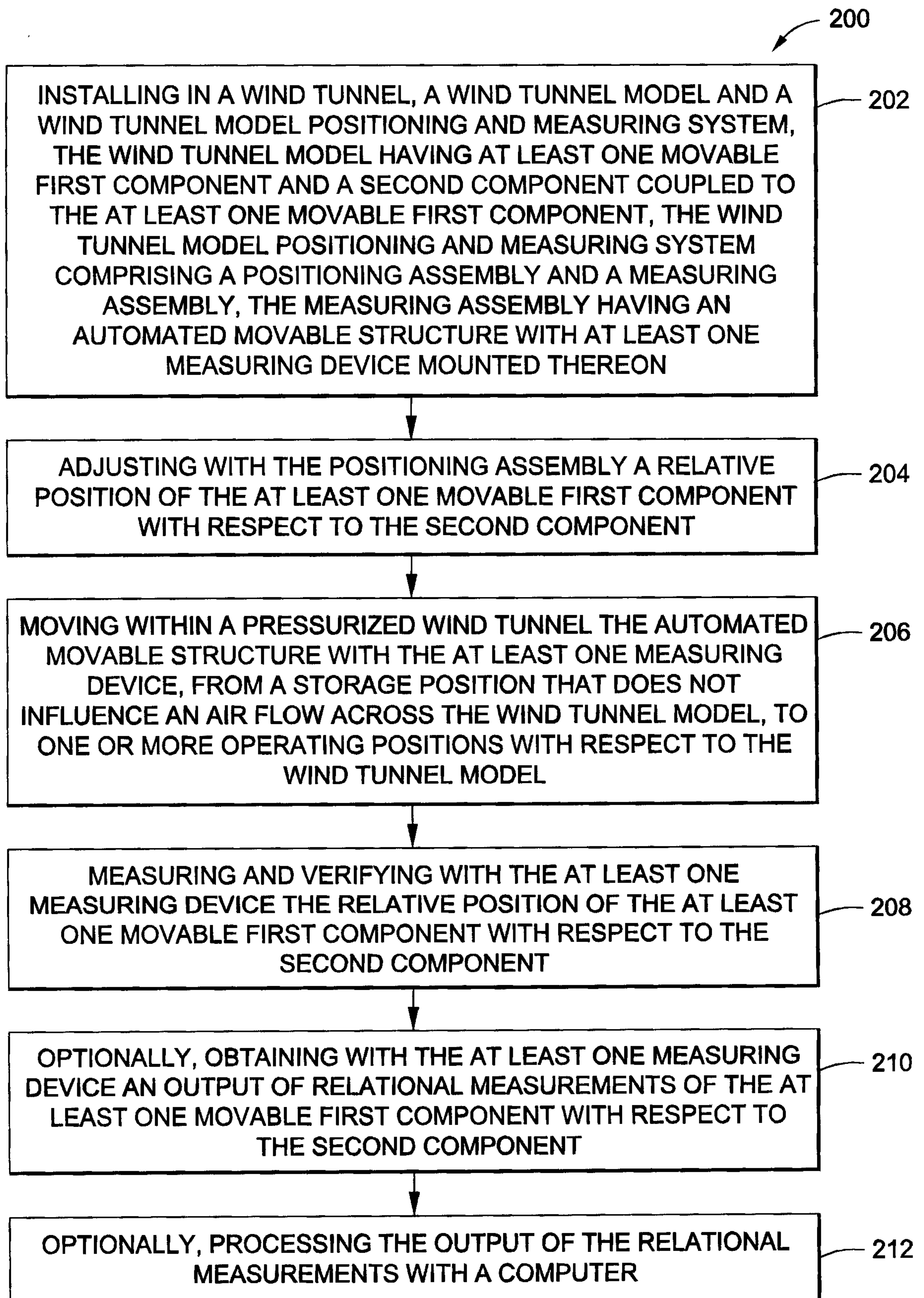

FIG. 8

