

19



Europäisches Patentamt  
European Patent Office  
Office européen des brevets



11 Publication number: **0 422 604 B1**

12

## EUROPEAN PATENT SPECIFICATION

45 Date of publication of patent specification: **08.06.94** 51 Int. Cl.<sup>5</sup>: **G03G 15/16, G03G 15/00**

21 Application number: **90119401.9**

22 Date of filing: **10.10.90**

54 **Image printer system.**

30 Priority: **13.10.89 JP 265204/89**

43 Date of publication of application:  
**17.04.91 Bulletin 91/16**

45 Publication of the grant of the patent:  
**08.06.94 Bulletin 94/23**

84 Designated Contracting States:  
**DE FR GB**

56 References cited:  
**DE-A- 3 513 438**  
**US-A- 4 583 834**  
**US-A- 4 753 543**  
**US-A- 4 780 740**

**PATENT ABSTRACTS OF JAPAN, vol. 7, no. 90 (P-191)(1235) 14 April 1983; & JP-A-58 017 468**

**PATENT ABSTRACTS OF JAPAN, vol. 12, no. 428 (M-762)(3275) 11 November 1988; & JP-A-63 160 938**

**PATENT ABSTRACTS OF JAPAN, vol. 13, no. 341 (P-907)(3689) 31 July 1989; & JP-A-1 099 075**

73 Proprietor: **HITACHI, LTD.**  
**6, Kanda Surugadai 4-chome**  
**Chiyoda-ku, Tokyo 101(JP)**

72 Inventor: **Wakamatsu, Kazuhiro**  
**9-3, Kokubuchu 2-chome**  
**Hitachi-shi(JP)**  
Inventor: **Sagae, Syoji**  
**1726-34, Omoricho**  
**Hitachiota-shi(JP)**  
Inventor: **Furukawa, Shigetaka**  
**13-10, Sekitanishi-2-chome**  
**Nakosomachi, Iwaki-shi(JP)**  
Inventor: **Kobayashi, Shinya**  
**2467, Motoyoshidacho**  
**Mito-shi(JP)**

74 Representative: **Altenburg, Udo, Dipl.-Phys. et al**  
**Patent- und Rechtsanwälte**  
**Bardehle . Pagenberg . Dost . Altenburg .**  
**Frohwitter . Geissler & Partner**  
**Galileiplatz 1**  
**D-81679 München (DE)**

**EP 0 422 604 B1**

Note: Within nine months from the publication of the mention of the grant of the European patent, any person may give notice to the European Patent Office of opposition to the European patent granted. Notice of opposition shall be filed in a written reasoned statement. It shall not be deemed to have been filed until the opposition fee has been paid (Art. 99(1) European patent convention).

EP 0 422 604 B1

PATENT ABSTRACTS OF JAPAN, vol. 13, no.  
412 (P-932)(3760) 12 September 1989; & JP-  
A-1 152 482

---

## Description

### BACKGROUND OF THE INVENTION

The present invention generally relates to an image printer system, and more specifically to such a control apparatus employed in an image printer system utilizing an electrophotographic technology, and capable of printing a high quality image on plural sorts of paper supplied from paper supply cassettes.

In an image printer system utilizing an electrophotographic technology, there are provided:

a rotatably driven photoconductive-sensitive body; a charging unit for uniformly charging the photoconductive-sensitive body; an exposing apparatus for exposing said uniformly charged photoconductive-sensitive body in response to an image signal inputted from an external apparatus so as to form an electrostatic latent image; a developing apparatus for developing the electrostatic latent image formed on the photoconductive-sensitive body to obtain a visible image; a paper transporting apparatus containing a paper supply cassette, for extracting paper onto which the visible image formed on the photoconductive-sensitive body is transferred from the paper supply cassette so as to be transported; a transferring apparatus for transferring the visible image formed on the photoconductive-sensitive body to said paper; and, a control apparatus for controlling said apparatuses. The control apparatus includes paper-sort-signal generating means for a paper sort signal in accordance with a sort of the paper, and also operating characteristic controlling means for controlling an operating characteristic of said transferring apparatus in response to the paper sort signal corresponding to the used paper.

When the above-described image printer system is generally known as a laser beam printer, the above-mentioned image signal is supplied from an upper grade information processing apparatus (external apparatus) such as a personal computer and a wordprocessor.

In such an image printer system, the normally used transferring apparatus is so constructed that a visible image (toner image) formed on the photoconductive-sensitive body is transferred to the paper by the electrostatic force produced by a potential applied to the paper, and the transfer characteristic is changed in accordance with the potential applied to this paper.

In JP-A-1-99075, such a transferring apparatus is disclosed that the paper supply cassette for setting therein post cards whose thicknesses are thicker than those of the normal paper can be discriminated, when the paper stored in this paper supply cassette is supplied, the transfer voltage is

increased so as to stabilize the transfer characteristic.

However, in this type of printer, there are many possibilities that even when the normal paper is used, the thickness thereof are different from each other. Also, there are many cases that the paper having different forms are selectively utilized. Such using states may depend upon users who operates the printers.

As previously described, the image printer system such as a laser beam printer is utilized so as to change the image signal furnished from the external information processing apparatus, e.g., a personal computer and a wordprocessor, into the visible image. Since this image printing apparatus owns the higher image printing capabilities (high-speed printing operation), there are many cases that a single image printing apparatus is commonly connected to a plurality of information processing apparatuses during the printing operation. In such cases, this image printing apparatus is positioned apart from the image processing apparatuses. Moreover, since the information processing apparatuses form the image information based upon various types of printing paper, this image printer system is desirable for printing out the image information on the various types of printing paper. The various types of printing paper implies, for instance, sizes of paper, forms of paper, and thicknesses of paper.

In the above-described conventional image printer systems, a plurality of paper supply cassettes capable of utilizing plural sorts of paper are simultaneously set and these paper supply cassettes are selectively used, plural sorts of paper supply cassettes are selectively substituted by each other so as to be set therein, or paper which are stored into paper supply cassettes are arbitrarily changed.

However, as described above, when the information processing apparatus is separated from the image printer system, the sorts of usable paper which have been set in the image printer system cannot be previously recognized at an arbitrary information processing apparatus, so that since an operator who is now at the information processing apparatus must repeatedly move between the image printing apparatus and this information processing apparatus in order to confirm the usable paper, it is very inconvenient to the operator.

The transferring apparatus employed in the image printer system disclosed in the above-described opened Japanese patent application may generate the signal for controlling the transfer condition, but can not provide information on presently usable paper to the information processing apparatus. Since the mark representative of the sort of paper stored into the paper supply cassette is fixed

on this paper supply cassette, there is another inconvenience that a large number (being equal to a quantity of the sorts of paper to be used) of paper supply cassettes must be prepared in order to identify a large number of the paper sorts. In the system of US-A-4 780 740 the size of paper available in a printer is automatically detected and sent to a remote computer for formatting purposes.

#### SUMMARY OF THE INVENTION

In accordance with the conventional image printer system, it is difficult to control the transfer conditions for printing out the high quality image on a large number of the paper sorts, and also is inconvenient because no confirmation can be made to the sorts of the paper which have been set in the image printer system and are not usable.

Therefore, an object of the present invention is to provide a useful image printer system capable of simplifying a printing control for a high quality image with respect to a large quantity of paper sorts, and of previously recognizing the usable paper set in the image printer system at an external information processing apparatus.

To achieve the above-described object, an image printer system according to claim 1 has been designed.

#### BRIEF DESCRIPTION OF THE DRAWINGS

Fig. 1 is a schematic block diagram of a image printer system according to a first preferred embodiment of the present invention;

Fig. 2 is a longitudinal section of a laser beam printer of the image printer system;

Fig. 3 is a perspective view of an exposure apparatus thereof;

Fig. 4 is a perspective view of both a paper supply cassette and a paper sort input means thereof;

Fig. 5 is a flowchart for explaining data processing operations performed by the printer and a CPU employed in an external information processing apparatus.

Fig. 6 is a schematic block diagram of a printer system according to a second preferred embodiment (modification) of the present invention;

Fig. 7 is a schematic block diagram of another printer system according to a third preferred embodiment (a further modification) of the present invention; and,

Fig. 8 is a perspective view of both a paper supply cassette and paper sort input means of the image printer system shown in Fig. 7.

#### DESCRIPTION OF PREFERRED EMBODIMENTS

Referring now to drawings, preferred embodiments of the present invention will be described.

Figs. 1 through 5 represent a first preferred embodiment according to the present invention.

This preferred embodiment is an image printer system employing a laser beam printer, while utilizing an electrophotographic technology. In Fig. 2, reference numeral 1 indicates a printer body or housing. A photoconductive-sensitive drum 10 is rotatably positioned at a center portion of this printer body 1, and is rotatably driven by a drive motor (not shown) at a constant velocity. Opposite to an outer surface of this photoconductive-sensitive drum 10, there are successively arranged a charger 20; an exposing apparatus 30; a developing apparatus 40; a transferring apparatus 50; a cleaner 60, and an eraser 70 along a rotation direction of this photoconductive-sensitive drum 10. Furthermore, there is provided a fixing apparatus 80 for heat-melting a toner image which has been transferred to paper by the above-described transferring apparatus 50, and fixing the melted toner image on this paper.

The charger 20 corresponds to a corona discharger, and uniformly charges the surface of the photoconductive sensitive drum 10.

In, as shown in Fig. 3, the exposing apparatus 30, a laser beam outputted from a semiconductor laser diode 31 in response to an image signal which has been inputted from an external information processing apparatus, converges by way of a coupling lens 32 so as to impinge on a scanner (motor-driven rotating mirror), whereby the laser beam is deflectedly scanned, and is exposed on the surface of the photoconductive-sensitive drum 10 via an FQ lens 35 and folded mirrors 36a, 36b and 36c (refer to Fig. 2), for a scanning purpose. An electrostatic latent image according to the image signal is formed on the surface of the photoconductive-sensitive drum 10 by means of this scanning exposure. Also, there are provided in this exposing apparatus 30, a folding mirror 39 and a beam detector 38 in order to detect a timing of the deflectedly-scanned laser beam which passes through a starting reference position of an exposure scanning of the photoconductive-sensitive drum 10.

The developing apparatus 40 has such a function to attach a toner on the electrostatic latent image which has formed on the surface of the photoconductive-sensitive drum 10 in order to change this electrostatic latent image into a visible image. Various types of known developing apparatuses may be utilized in accordance with necessities. As one example, it is preferable to employed a reversal developing apparatus in this laser

beam printer, by which a toner is attached on a region whose electron charge has disappeared by receiving an exposing beam.

The transfer apparatus 50 is equipped with a drive roller 51; a driven roller 52; an endless transfer belt 54 made of an insulating material, which is set on a peripheral portion of an adjusting roller 53; a belt charger 55 for charging this transfer belt 54; a suction auxiliary roller 56 for electrostatic-sucking paper which has been supplied from a paper supply apparatus (will be discussed later), onto an outer peripheral surface of the charged transfer belt 54; a transfer auxiliary roller 57 for firmly electrostatic-transferring the toner image on the paper, while the paper sucked-transported on the transfer belt 54 is firmly in contact with the surface of the photoconductive-sensitive drum 10; and also a belt cleaner 58. The drive roller 51 is so designed to be rotated by a drive motor (not shown) in such a manner that the above-described transfer belt 54 is rotated in synchronism with the moving velocity of the outer peripheral surface of the photoconductive-sensitive drum 10. A total length of the transfer belt 54 is longer than a maximum size of usable printing paper. During a color printing operation, while sucking paper on the outer peripheral surface of this transfer belt 54, this paper is repeatedly rotated several times and is in contact with the surface of the photoconductive-sensitive drum 10 several times. During a monochrome image printing operation, paper onto which the toner image has been transferred is entered in a straight way into the fixing apparatus 80.

The function of the cleaner 60 is to remove toners which were not transferred on the paper and remain on the surface of the photoconductive sensitive drum 10. The function of the eraser 70 is to uniformly expose an electrostatic latent image remaining on the surface of the photoconductive-sensitive drum 10 so as to erase this latent image.

The fixing apparatus 80 includes a heating roller 81 and a back-up roller 82, and has such a function to melt a toner image so as to fix a melted toner image on paper while passing the paper on which the toner image has been transferred through the above-described two rollers 81 and 82.

A paper transporting apparatus is equipped with a paper supply apparatus 100 for supplying paper and also a paper eject apparatus 200 for ejecting printed paper.

The paper supply apparatus 100 is equipped with paper supply cassettes 110 and 120 which are detachably set on cassette inserting holes 1a and 1b formed on a side wall of the printer body 1. Paper 301 and 302 which has been stored into the paper supply cassettes 110 and 120, is selectively extracted from opening units of cassette covers 111 and 121 of these paper supply cassettes 110

and 120 from the upper paper supply cassette. When a plurality of paper have been extracted, one piece of paper is separated in cooperation with separating pads 141 and 142 so as to be supplied via a paper guide 150 to a resist roller 160. This resist roller 160 is to adjust both an attitude of this paper 301 (302) and a transporting timing thereof in such a way that a leading edge of a toner image formed on the surface of the photoconductive-sensitive drum 10 is coincident with a leading edge of the paper 301 (302).

As represented in Fig. 4, on a front wall of the paper supply cassette 110, there is provided a size mark 112 having a notch 112a representative of a size of the paper 301 stored into the paper supply cassette 110, whereas there are provided on the upper surface of the cassette cover 111, a name plate 113 on which both a paper form of the paper 301 stored into this paper supply cassette 110 and a sort of paper thickness have been written; a paper form mark 114 by which the paper can be set by selectively moving the mark to a position where the paper form of the paper stored into this paper supply cassette 110 has been written; and also a paper thickness mark 115. The paper form mark 114 is equipped with a knob unit 114a for holding this paper form mark 114 when the mark 114 is moved to a selected position and a light reflecting unit 114b for recognizing existence of this mark 114. The paper thickness mark 115 is arranged by a knob unit 115a for holding the paper thickness mark 115 when moving this mark 115 to a selected position, and also a light reflecting unit 115b for recognizing presence of this mark 115.

There are five sorts of paper sizes of the paper 301 (302) usable in the laser beam printer according to the first preferred embodiment. Then, five sorts of paper supply cassettes 110 (120) are prepared which are equipped with paper size marks 112 where the notches 112a have been formed at the positions indicative of paper sizes of the paper to be stored in the paper supply cassettes. Then, the total sort of the available paper 301 (302) is five and the above-described name plates 113 on which the five sorts of paper have been written are made on all of the paper supply cassettes 110 (120). The forms of paper are two, which are indicated by normal paper and letter head at the setting position of the paper form mark 114, and paper thickness are three different thickness (thinner thickness = 161 lbs, 60 g/m<sup>2</sup>; medium thickness = 201 lbs, 75 g/ m<sup>2</sup>; thicker thickness = 241 lbs, 90 g/ m<sup>2</sup>), which are indicated by the setting position of the paper thickness mark 115.

The printer body 1 includes a transmission type photo-sensor 410 for reading the position of the notch of the paper size mark 112, and a reflection type photo-sensor 420 for reading set positions

of the sort marks 114 and 115. Five sets of the transmission type photo-sensor 410 are so arranged that these photosensors are coincident with predetermined positions for the notches in such a manner that each paper size mark 112 is interposed between an oppositely positioned LED and a light receiving element. Five sets of reflection type photo-sensor 420 are so arranged that the light reflection unit 114b of the paper form mark 114, LED which has been positioned opposite to a light receiving element in such a manner that light reflected from the light reflecting unit 115b of the paper thickness mark 115 is inputted, and the light receiving elements are coincident with predetermined positions for setting the light reflecting units 114b and 115b.

The paper eject apparatus 200 is equipped with a paper guide 210 for transporting the fixed paper 301 (302) delivered from the fixing apparatus 80 up to the upper portion of the printer body 1; transporting rollers 221 and 222; and also a paper ejecting roller 240 for ejecting the transported paper 301 (302) onto the paper eject tray 230.

In the printer body 1, there is employed a control unit 500 at the upper portion of this body, which is to be connected to the above-described constructive elements and external information processing apparatus.

Fig. 1 is a schematic block diagram of an image printer system including the above-described control unit 500, and also electrical connections of the constructive elements and external information processing apparatus connected to this control unit 500.

The control unit 500 is arranged by a CPU 501 as a main control element. This control unit 500 further includes: a clock circuit 502 for generating a clock signal corresponding to an operation reference signal for this CPU 501; ROM 503 into which a detection signal is inputted by the CPU 501, and which produces a control signal so as to be outputted therefrom, and has stored therein a program and control base data and the like for performing a data processing operation in order to communicate with an external information processing apparatus 600 (will be described later); and RAM 504 for temporarily storing therein data under process by the CPU 501. The control unit 500 also includes: comparators 505 and 506 for binary-coding detection signals derived from two photo-sensors 410 and 420; an input port 507 for inputting the binary-coded detection signals outputted from the comparators 505 and 506 into the CPU 501; an output port 508 for outputting the control signals derived from the CPU 501; a laser controller 509 for controlling tuning ON/OFF the semiconductor laser diode 31 in response to the image signal in synchronism with the reference position signal outputted

from the beam detector 38; and also a communication circuit 510 for communicating with the external information processing apparatus 600 under control of the CPU 501 so as to send/receive the data with the laser controller 509.

The photo-sensor 410 is equipped with an LED 411 and a light receiving element 412, whereas the photo-sensor 420 is arranged by an LED 421 and a light receiving element 422.

Under instruction from the CPU 501, the output port 508 outputs a signal for controlling a magnitude of an output voltage of a high-voltage power source 91 for generating a high voltage to be applied to the above-described belt charger 55; outputs another control signal for controlling a voltage control circuit 92 to control a potential of the suction auxiliary roller 56; and also outputs a further control signal for controlling a scanner controller 93 to control the rotation velocity of the scanner (drive motor) 33.

The external information processing apparatus 600 is mainly arranged by a host CPU 601. This external information processing apparatus 600 is so designed that in accordance with a process function instruction inputted from the keyboard 603 via the keyboard control circuit 602 and also process data, the image information processing operation is executed so as to store this image data into a bit map memory 604, this image data is displayed on a CRT display unit 606 under control of the CRT controller 605, and the image data is outputted as video data to the communication circuit 510 of the control unit 500 under control of the printer controller 607.

The contents of the data processing operations performed by the CPU 501 employed in the laser beam printer of the image printer system with the above-described arrangement, and effected by the CPU 601 employed in the external information processing apparatus for printing the images will now be described with reference to Fig. 5.

The CPU 501 employed at the control unit (500) is brought into a state for waiting for a print instruction signal and also controls the fixing apparatus 80 at a preselected temperature when a power supply is turned ON (a processing step 701).

When an operator manipulates the keyboard 603 at the external information processing apparatus 600 in order to instruct a printing operation of image information, the CPU 601 outputs the print instruction signal to the printer controller 607 (a processing step 721) and the printer controller 607 sends this print instruction signal to the communication circuit 510 employed at the control unit (500).

Upon receipt of this print instruction signal, the CPU 501 employed at the control unit (500) checks

the detection signals derived from the photo-sensors 410 and 420 (a processing step 702) so as to confirm both the paper sizes and paper sorts of the paper 301 and 302 which have been set into the paper supply cassettes 110 and 120 loaded on the cassette loading holes 1a and 1b, and also to check operation states of other constructive elements, whereby confirmation can be established whether or not the printing operation is available, and furthermore transfers these check results as state signals via the communication circuit 510 to the external information processing apparatus (a processing step 703).

When the CPU 601 employed at the information processing apparatus receives this state signal via the printer controller 607, this CPU 601 checks this state signal in order to display on the CRT display unit, the paper sizes and sorts of the paper 301 and 302 which have been stored into the paper supply cassettes 110 and 120 loaded on the printer, and also whether or not the printing operation is available. Then, this CPU 601 requests a selection instructing input for the relevant paper supply cassette when the paper has been set whose size and sort are coincident with those of image information to be printed out, and requests the paper supply cassettes 110 and 120 for storing the relevant paper into the cassette loading holes 1a and 1b when the desired size and sort of the paper are not prepared (a processing step 722).

When the paper supply cassette 110 which has stored the paper to be used is instructed by the keyboard 603, the CPU 601 stores the image information to be printed out as the dot data in the bit map memory 604 (a processing step 723) and transfers a print starting instruction signal containing a paper supply cassette selecting signal via the printer controller 607 to the printer side when the image information storage is completed (a processing step 724).

Upon receipt of this print starting instruction signal via the communication circuit 510, the CPU 501 employed at the printer side sets a Busy N at a low level, and controls the various drive power supplies so as to start the photoconductive-sensitive drum 10, charger 20, exposing apparatus 30, developing apparatus 40, transferring apparatus 50, cleaner 60, eraser 70 and fixing apparatus 80. At this time, the control data which has been stored in ROM 503 is read out in response to the paper supply cassette selecting signal in order to charge the transfer belt 54 at an optimum value with respect to the sort of used paper, and the output voltage from the high voltage power supply 91 is controlled. Similarly, the voltage control circuit 92 is controlled so as to control the potential of the suction auxiliary roller 56. The toner image formed on the photoconductive-sensitive drum 10 is trans-

ferred to the paper 301 by receiving the effect of the electrons charged on the transfer belt 54. The transfer efficiency is sensitive also to the surface potential of the paper 301. When the surface potential of the paper 301 is increased, the transfer efficiency is also increased. However, if the surface potential becomes too high, discharge may happen to occur between the charged paper 301 and photoconductive-sensitive drum 10, which results in lowering of image quality. Taking account of such circumstances, the control data required for achieving the optimum belt charging voltage and also optimum surface potential in accordance with the sort of the used paper 301 has been previously stored into ROM 503, and thus the CPU 501 reads out this control data so as to optimize the controls of the above-described high voltage power supply 91 and voltage control circuit 92 (a processing step 704).

Thereafter, one sheet of paper 301 (302) which have been stored into the paper supply cassette 110 (120) instructed by the paper supply cassette selecting signal is extracted and then supplied to the register roller 160 (a processing step 705).

Upon completion of the printing preparation, the CPU 501 generates a vertical synchronization signal at a timing of T1 (print starting timing signal in the paper supply direction), and transfers the vertical synchronization signal via the communication circuit 510 to the information processing-apparatus 600. As a result, the CPU 601 employed at the information processing apparatus 600 enters into a transmission preparation state for the image data (image signal) stored into the bit map memory 604. Subsequently, the deflection position of the laser beam becomes a starting reference position for exposure scanning, and the communication circuit 510 is controlled in order to transfer the horizontal synchronization signal obtained from the beam detector 38 to the information processing apparatus 600 (a processing step 706).

Upon receipt of this horizontal synchronization signal, the CPU 601 employed at the information processing apparatus transmits the image signal scanned for one scanning period in synchronism with this horizontal synchronization signal (a processing step 725).

The CPU 501 employed at the control unit (50) supplies this image signal to the laser controller 509 in order to control the communication circuit 510 enabling the laser diode 31 to be turned ON/OFF and enters into the scanning operation (a processing step 707).

The electrostatic latent image formed by the above-described scanning operation is formed as a toner image by the developing apparatus 40. To synchronize this toner image with the timing at which this toner image reaches the transfer posi-

tion, the resist roller 160 is rotated at T2 so as to restart the transportation of the paper 301 (302), and thus the toner image formed on the photoconductive-sensitive drum 10 is transferred on the paper 301. When the paper 301 onto which the toner image has been transferred passes through the fixing apparatus 80, the toner image is fixed thereon and thereafter ejected on the paper eject tray 230 of the paper ejecting apparatus 200 (a processing step 708).

Busy N of the CPU 501 becomes a high level while printing the image signal consisting of one page, and is brought into a condition for waiting for a printing instruction signal of a next page. Then, when confirmation is made that no printing instruction signal for the subsequent page is inputted within a predetermined time period (i.e., a time period until the printed paper has been ejected) (a processing step 709), the various drive motors are stopped (a processing step 710).

Accordingly, in case that there are plural pages of image information to be printed out, when the CPU 601 employed at the side of the information processing apparatus 600 accomplishes the transmission of the image information on the previous page, the image data on the next page is immediately stored in the bit map memory 604, and before the CPU 501 executes the stop processing operation, the CPU 601 generates the printing instruction signal for the next page and repeats the data processing operation for the printing operation.

In accordance with the printing system with the above-described arrangement, the printer can control the transfer conditions at the optimum states in response to the sorts of the paper 301 (302) used in the printer. Also, since the quick recognition can be achieved which sort of the paper has been set to the connected printer at the side of the external information processing apparatus, the printing image quality can be improved and simultaneously the easy operation can be achieved.

In Fig. 6, there is shown a modification of the image printer system according to the present invention, in which sort information among the sorts of the paper set in the above-described printer may be inputted by operating switches of an operation panel 94 employed on the upper portion of this printer. In this case, since the data indicative of the sort of the set paper has been previously stored into RAM 504, a back-up battery 511 is connected to this RAM 504 in order not to lose this data even when the power supply is turned OFF. The CPU 501 continuously monitors whether or not the paper supply cassettes 110 and 120 are loaded. When the paper supply cassettes 110 and 120 are loaded or unloaded on this printer, the CPU 501 requests the display lamp employed in the operation panel

94 to be flickered in order that the sort information of the paper which has been stored into these cassettes is inputted into this operation panel 94. Then, when no sort information of the paper stored in the paper supply cassette is inputted, this stored paper is recognized as normal paper. When the paper supply cassette is loaded or unloaded in case of interruption of the power source, the CPU 501 requests the sort information to be inputted under condition that only the paper size has been changed and the power source is turned ON.

In accordance with this modification, there is a particular advantage that the printer may be constructed at reasonable cost.

Figs. 7 and 8 represent another modification of the image printer system according to the present invention. In this printer, there is provided a pocket 116 on a side wall of the paper supply cassette 110, into which a bar code label 310 representative of a product name (sort) of paper stored into this paper supply cassette 110 is inserted. Furthermore, a bar code reader 95 for reading this bar code label 310 of the paper supply cassette 110 loaded on the cassette loading holes 1a and 1b is employed within the printer body 1. The bar code label 310 may be obtained by either stripping, or cutting away a product name attached on wrapping paper 320 for paper.

Also, a bar code reader controller 512 is employed in the control unit 500, which transfers the paper sort information (product name) read by the bar code reader 95 to the CPU 501. In ROM 503, there is stored control data on the belt charging voltage suitable for this paper and also the surface potential of the paper in accordance with this read paper name. The CPU 501 reads out this control data from ROM 503 based upon the paper name information read by the bar code reader 95, so as to control both the high-voltage power supply 91 and potential control circuit 92.

In case that no control data corresponding to the paper name information read by the bar code reader 95 has been stored into ROM 503, the CPU 501 requests the control data to be inputted by the operation panel. If no input is entered from the operation panel, the paper stored into the cassette is handled as normal paper.

When a print instruction is received from an external information processing apparatus, paper name information is transferred to the information processing apparatus so as to be displayed thereon.

It should be noted that other constructions of this image printer system are common with those of the above-described printer system.

It should also be noted that although each of the above-described preferred embodiments has

employed the belt transferring apparatus, a corona transferring apparatus may be alternatively employed with a similar effect.

While the present invention has been described in detail, since after arbitrary paper has been stored into the paper supply cassette, the sort of this paper can be intentionally set by the operator, there is no necessity to prepare a large number of paper supply cassettes in the image printing apparatus. Furthermore, since the set-paper-sort signal outputting means delivers to the external apparatus the paper sort signal corresponding to the paper which have been stored into all of the paper supply cassettes set in this image printer system, it is convenient in the external information processing apparatus which can previously recognize the usable paper set in this image printer system.

Moreover, the operating characteristic control of the transferring apparatus can be firmly performed in accordance with the used paper.

#### Claims

1. An image printer system including:
  - an external information processing apparatus (600) for generating an image information to be printed;
  - a rotatably driven photoconductive-sensitive body (10);
  - a charging apparatus (20) for uniformly charging the photoconductive-sensitive body;
  - an exposing apparatus (30) for exposing said uniformly charged photoconductive-sensitive body in response to an image signal inputted from said external information processing apparatus so as to form an electrostatic latent image;
  - a developing apparatus (40) for developing the electrostatic latent image formed on the photoconductive-sensitive body to obtain a visible image;
  - a paper transporting apparatus (100; 200) containing a paper supply cassette (110; 120), for extracting paper onto which the visible image formed on the photoconductive-sensitive body is transferred from the paper supply cassette so as to be transported;
  - a transferring apparatus (50) for transferring the visible image formed on the photoconductive-sensitive body to said paper; and
  - paper-sort-signal generating means (112, 114, 115, 410, 420) for generating a paper sort signal in accordance with a sort of the paper stored into said paper supply cassette;
  - set-paper-sort-signal outputting means (507, 410) for sending said paper sort signal to said external information processing apparatus; and

a printer body (1) provided with a control unit (501) for controlling said apparatuses, characterized in that

- (a) said external information processing apparatus (600) is provided with;
  - a display unit (605, 606) for displaying the paper information of the paper stored into said paper supply cassette set in said printer body (1) on the basis of said paper sort signal transmitted from said printer body (1), and for indicating said paper information to an operator,
  - inputting means (602, 603) for inputting an instruction necessary for printing said image information, and
  - means (601, 607) for generating a paper supply cassette selection signal to select said paper supply cassette storing the paper adaptable for printing the image information and for transmitting said paper supply cassette selection signal to said printer body (1),
- (b) and, said printer body (1) is provided with;
  - plurality of cassette inserting holes (1a, 1b) on which paper supply cassettes are detachably set, and
  - plurality of paper supply cassettes (110, 120) which are provided with indicators (112, 114, 115) representative of the size and the sort of the stored paper and are detachably set on said cassette inserting holes,
  - whereby said paper-sort signal generating means (112, 114, 115, 410, 420) generates said paper sort signal corresponding to said indicators of each of said set paper supply cassettes,
  - and said control unit (501) is provided with;
    - operating characteristic controlling function (704) for controlling an operating characteristic of said transferring apparatus in response to the paper stored into the selected paper supply cassette in accordance with the paper supply cassette selection signal transmitted from said external information processing apparatus, and
    - paper supply controlling function (705) for selecting and supplying said selected paper supply cassette.
2. An image printer according to claim 1, characterized in that said indicators (112, 114, 115) represent the size, form and sort of the paper.

## Patentansprüche

1. Bilddruckersystem, enthaltend:
  - ein externes Informationsverarbeitungsgerät (600) zur Erzeugung einer zu druckenden Bildinformation; 5
  - einen drehbar angetriebenen fotoleitend empfindlichen Körper (10);
  - ein Aufladungsgerät (20) zur einheitlichen Aufladung des fotoleitend empfindlichen Körpers; 10
  - ein Belichtungsgerät (30) zur Belichtung des einheitlich aufgeladenen fotoleitend empfindlichen Körpers als Reaktion auf ein Bildsignal, das von dem externen Informationsverarbeitungsgerät eingegeben wird, um so ein elektrostatisches latentes Bild zu erzeugen; 15
  - ein Entwicklungsgerät (40) zur Entwicklung des elektrostatischen latenten Bildes, das auf dem fotoleitend empfindlichen Körper gebildet wird, um ein sichtbares Bild zu erhalten; 20
  - ein Papiertransportgerät (100, 200), enthaltend eine Papierzufuhrkassette (110, 120) zum Extrahieren von Papier, auf das das sichtbare Bild, gebildet auf dem fotoleitend empfindlichen Körper, übertragen wird, aus der Kassette zwecks Transports; 25
  - ein Übertragungsgerät (50) zum Übertragen des sichtbaren Bildes, das auf dem fotoleitend empfindlichen Körper gebildet wird, auf das Papier; und 30
  - Einrichtungen (112, 114, 115, 410, 420) zur Erzeugung eines Papiersortensignals entsprechend der in der Papierzufuhrkassette gespeicherten Papiersorte; 35
  - Einrichtungen (507, 410) zur Ausgabe eines Einsatz-Papiersortensignals, um dieses Signal an das externe Informationsverarbeitungsgerät zu senden; und
  - einem Druckerkörper (1) mit einer Steuereinheit (501) zur Steuerung der Geräte, dadurch gekennzeichnet, daß 40
    - a) das externe Informationsverarbeitungsgerät (600) aufweist:
      - eine Displayeinheit (605, 606) zum Display der Papierinformation des Papiers, das in der in den Druckerkörper eingesetzten Papierzufuhrkassette gespeichert ist, auf der Basis des Papiersortensignals, das von dem Druckerkörper (1) übertragen wird, und zur Anzeige der Papierinformation an die Bedienperson, 45
      - eine Eingabeeinrichtung (602, 603) zur Eingabe einer Instruktion, die zum Drucken der Bildinformation erforderlich ist, und 50
      - eine Einrichtung (601, 607) zur Erzeugung eines Papierzufuhrkassetten-Auswahlsignals zur Auswahl der Papierzufuhrkassette, 55

die das zum Drucken der Bildinformation anwendbare Papier speichert, und zur Übertragung des Papierzufuhrkassetten-Auswahlsignals an den Druckerkörper (1), und daß b) der Druckerkörper (1) ausgerüstet ist mit einer Mehrzahl von Kassetteneinführungsöffnungen (1A, 1B), in die Papierzufuhrkassetten abnehmbar eingesetzt sind, und

einer Mehrzahl von Papierzufuhrkassetten (110, 120), die mit Anzeigern (112, 114, 115) versehen sind, die repräsentativ für Größe und Sorte des gespeicherten Papiers sind und abnehmbar in die Kassetteneinführungsöffnungen eingesetzt sind,

wobei die Einrichtung zur Erzeugung von Papiersortensignalen (112, 114, 115, 410, 420) das Papiersortensignal erzeugt, das den Anzeigern jeder der eingesetzten Papierzufuhrkassetten entspricht,

und daß die Steuereinheit (501) versehen ist mit

einer Betriebscharakteristik-Steuerfunktion (704) zur Steuerung der Betriebscharakteristik des Übertragungsgerätes in Reaktion auf das in der ausgewählten Papierzufuhrkassette gespeicherten Papiers entsprechend dem Papierzufuhrkassetten-Auswahlsignal, das von dem externen Informationsverarbeitungsgerät übertragen wird, und

einer Papierzufuhr-Steuerfunktion (705) für Auswahl und Zufuhr der ausgewählten Papierzufuhrkassette.

2. Bilddrucker nach Anspruch 1, dadurch gekennzeichnet, daß die Anzeiger (112, 114, 115) die Größe, die Form und die Sorte des Papiers repräsentieren.

## Revendications

1. Système d'impression d'images comprenant :
  - un dispositif externe de traitement d'informations (600) servant à produire une information d'image devant être imprimée;
  - un corps photoconducteur sensible (10) entraîné en rotation;
  - un dispositif de charge (20) servant à charger uniformément le corps photoconducteur sensible;
  - un dispositif d'exposition (30) servant à exposer ledit corps photoconducteur sensible chargé de façon uniforme, en réponse à un signal d'image introduit à partir dudit dispositif extérieur de traitement d'images, de manière à former une image latente électrostatique;
  - un dispositif de développement (40) servant à

développer l'image latente électrostatique formée sur le corps photoconducteur sensible pour l'obtention d'une image visible;

un dispositif de transport de papier (100; 200) contenant une cassette d'alimentation en papier (110; 120), pour extraire du papier sur lequel l'image visible formée sur le corps photoconducteur sensible est transférée à partir de la cassette d'alimentation en papier pour être entraînée;

un dispositif de transfert (50) pour transférer l'image visible formée sur le corps photoconducteur sensible, sur ledit papier; et

des moyens (112, 114, 115, 410, 420) de production de signaux de type de papier pour produire un signal de type de papier en fonction d'un type du papier stocké dans ladite cassette d'alimentation en papier;

des moyens (507, 410) de délivrance d'un signal de type de papier réglé pour l'envoi dudit signal de type de papier audit dispositif externe de traitement d'informations; et

un corps d'imprimante (1) équipé d'une unité de commande (501) servant à commander lesdits dispositifs, caractérisé en ce que

(a) ledit dispositif externe (600) de traitement d'informations comporte :

une unité d'affichage (605, 606) servant à afficher l'information du papier stocké dans ladite cassette d'alimentation en papier placée dans ledit corps d'imprimante (1), sur la base dudit signal de type de papier transmis par ledit corps d'imprimante (1) et servant à indiquer ladite information concernant le papier à un opérateur,

des moyens d'entrée (602, 603) servant à introduire une instruction nécessaire pour l'impression de ladite information d'image; et

des moyens (601, 607) pour produire un signal de sélection de cassette d'alimentation en papier pour sélectionner ladite cassette d'alimentation en papier stockant le papier pouvant être adapté pour l'impression de l'information d'image et pour la transmission dudit signal de sélection de cassette d'alimentation en papier audit corps d'imprimante (1), et

(b) ledit corps d'imprimante (1) comporte :

une pluralité de trous d'insertion de cassette (1a, 1b), dans lesquels des cassettes d'alimentation en papier sont fixées de façon amovible, et

une pluralité de cassettes d'alimentation en papier (110, 120), équipées d'indicateurs (112, 114, 115) représentatifs de la taille et du type du papier stocké et qui sont fixées de façon amovible dans lesdits trous d'in-

sertion de cassettes,

lesdits moyens (112, 114, 115, 410, 420) de production du signal de type de papier produisant ledit signal de type de papier qui correspond auxdits indicateurs de chacune desdites cassettes d'alimentation en papier positionnées, et

ladite unité de commande (501) comporte :

une fonction (704) de commande de caractéristique de fonctionnement, servant à commander une caractéristique de fonctionnement dudit dispositif de transfert en réponse au papier stocké dans ladite cassette sélectionnée d'alimentation en papier en fonction du signal de sélection de cassette de la cassette d'alimentation en papier, transmis par ledit dispositif externe de traitement d'informations, et

une fonction de commande d'alimentation en papier (705) pour sélectionner et délivrer ladite cassette sélectionnée d'alimentation en papier.

2. Imprimante d'images selon la revendication 1, caractérisée en ce que lesdits indicateurs (112, 114, 115) représentent la taille, la forme et le type de papier.

FIG. 1

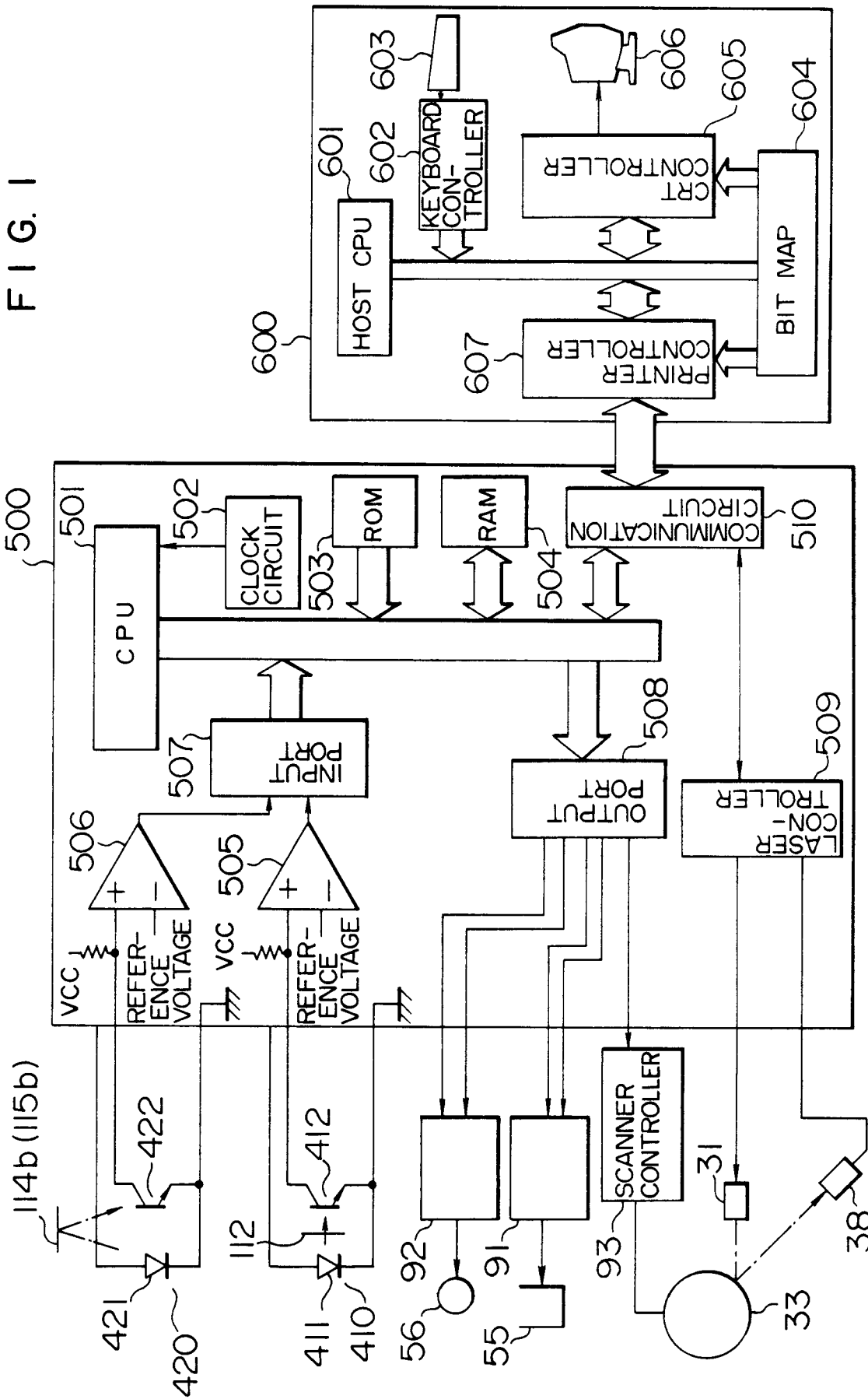

FIG. 2

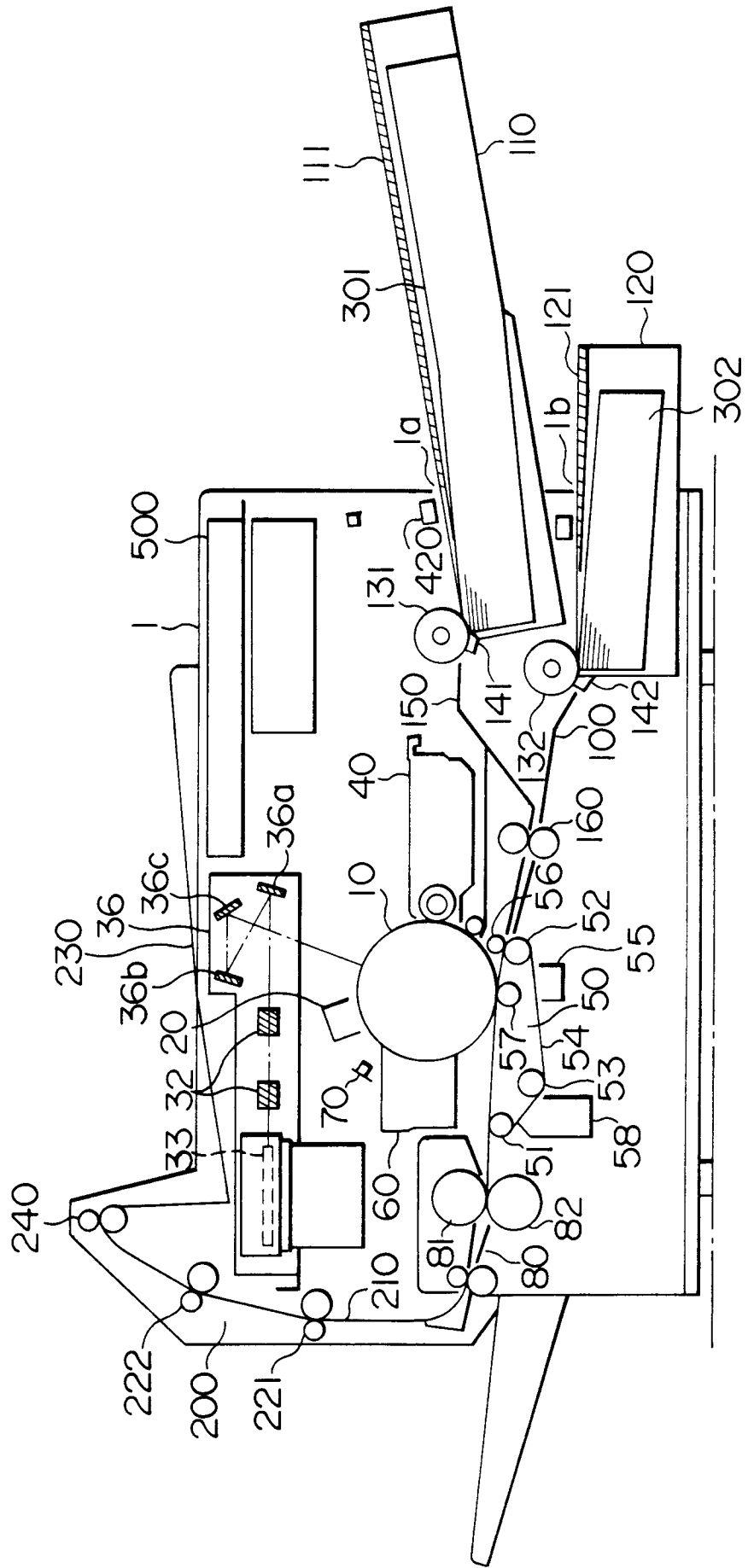

FIG. 3

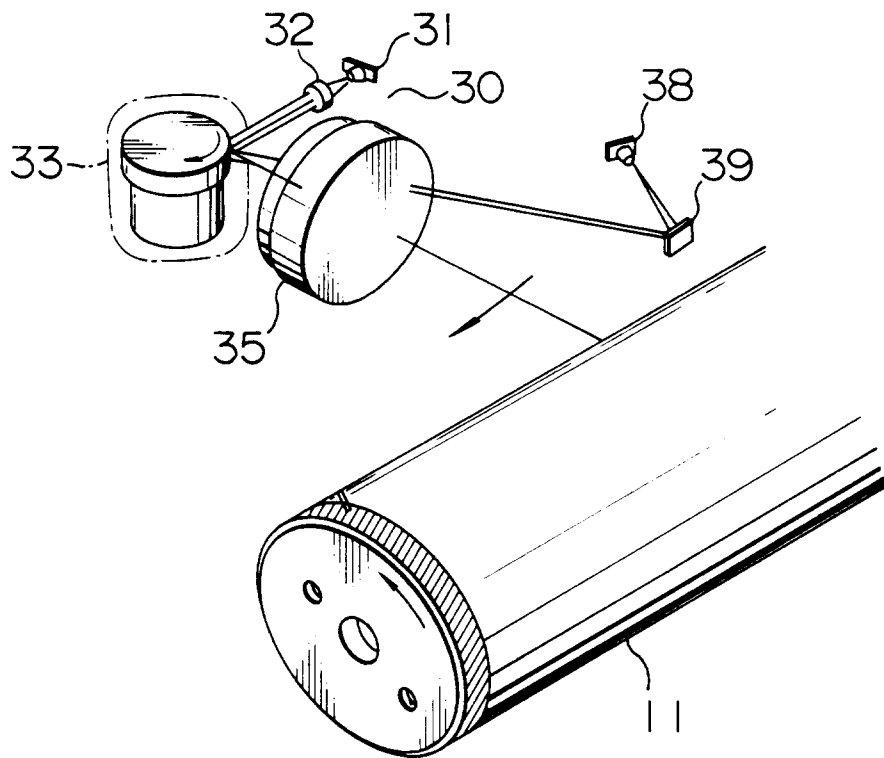

FIG. 4

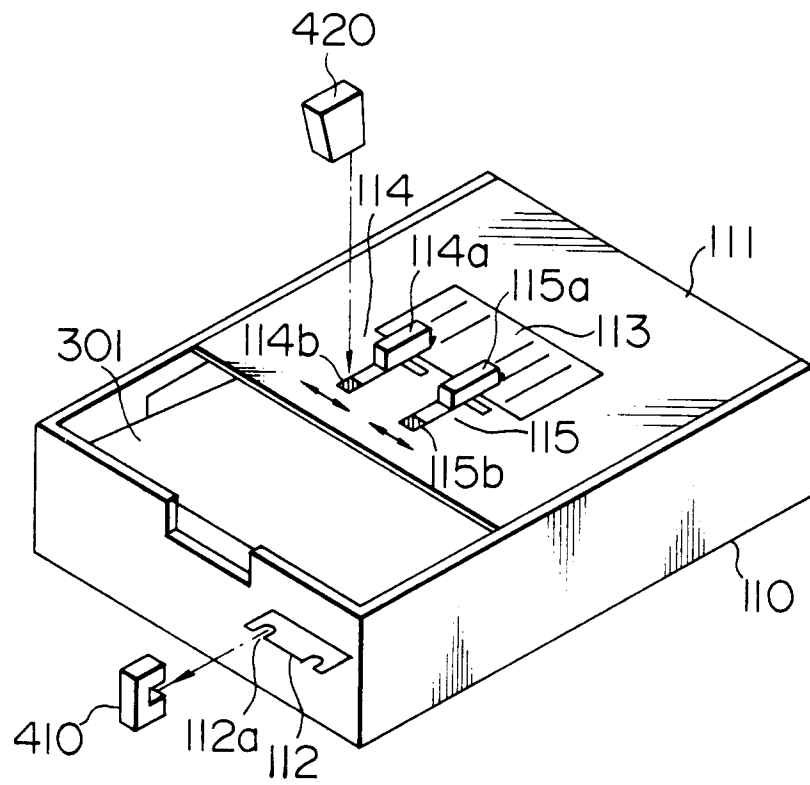

FIG. 5

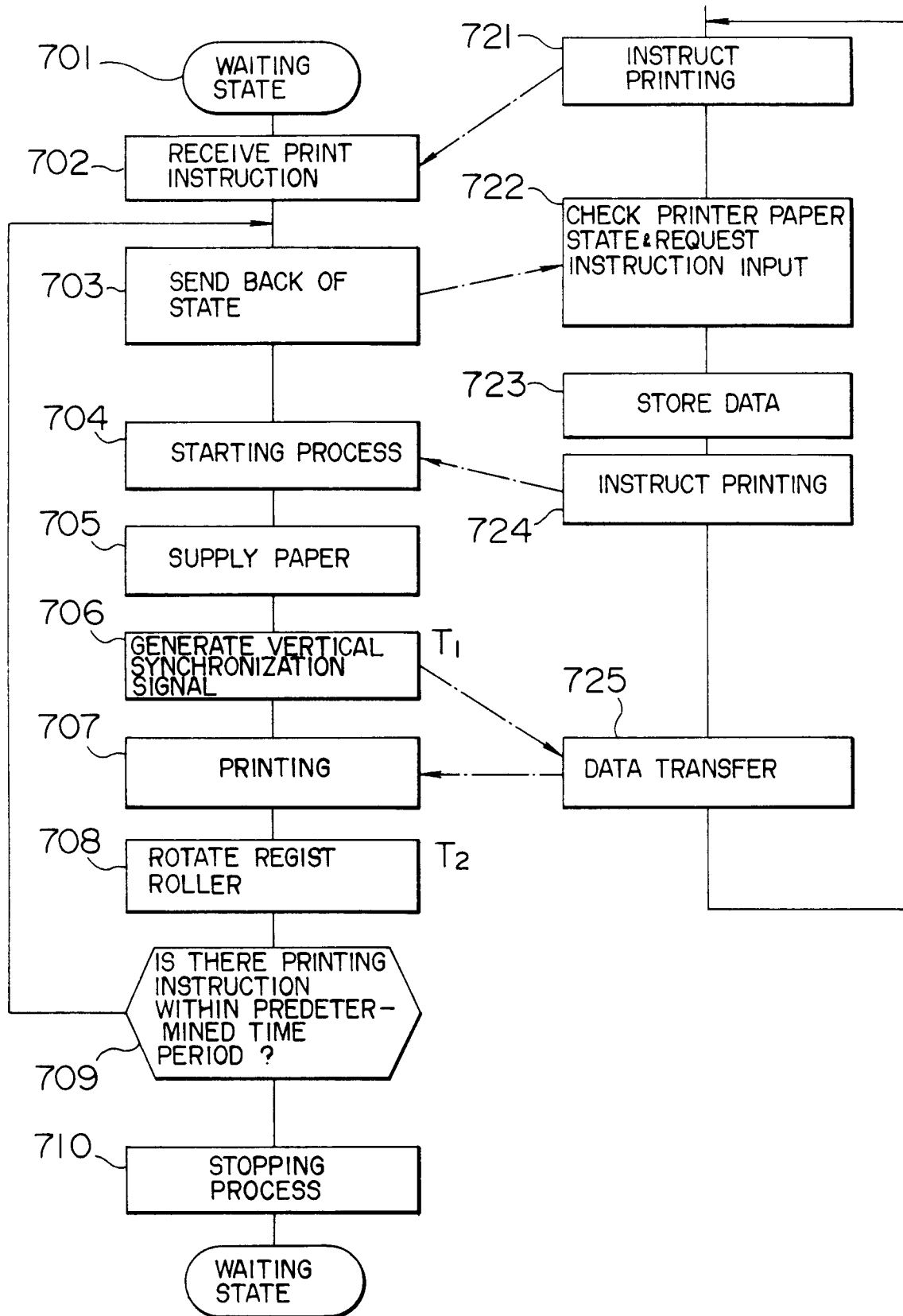

FIG. 6

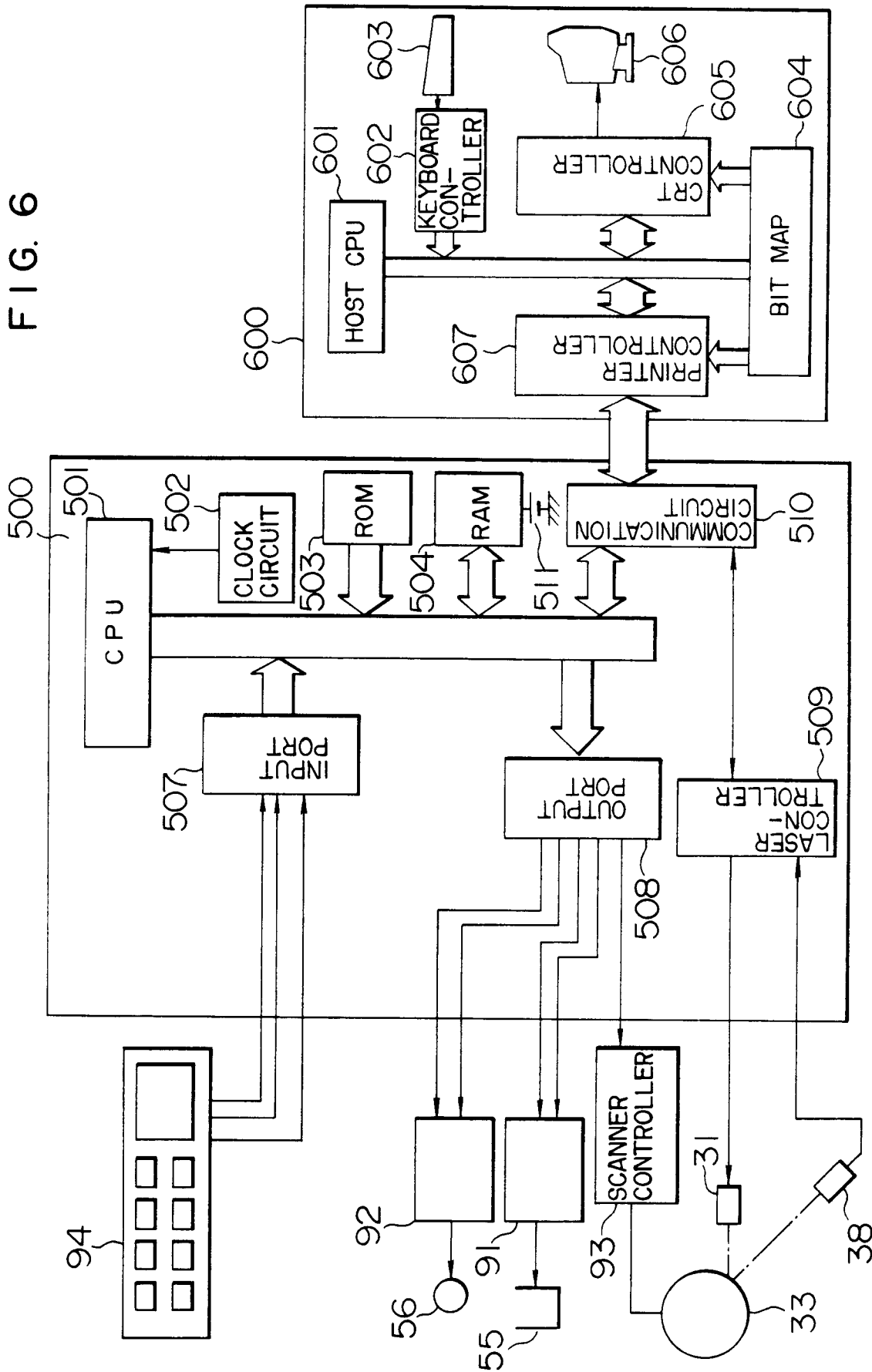

FIG. 7

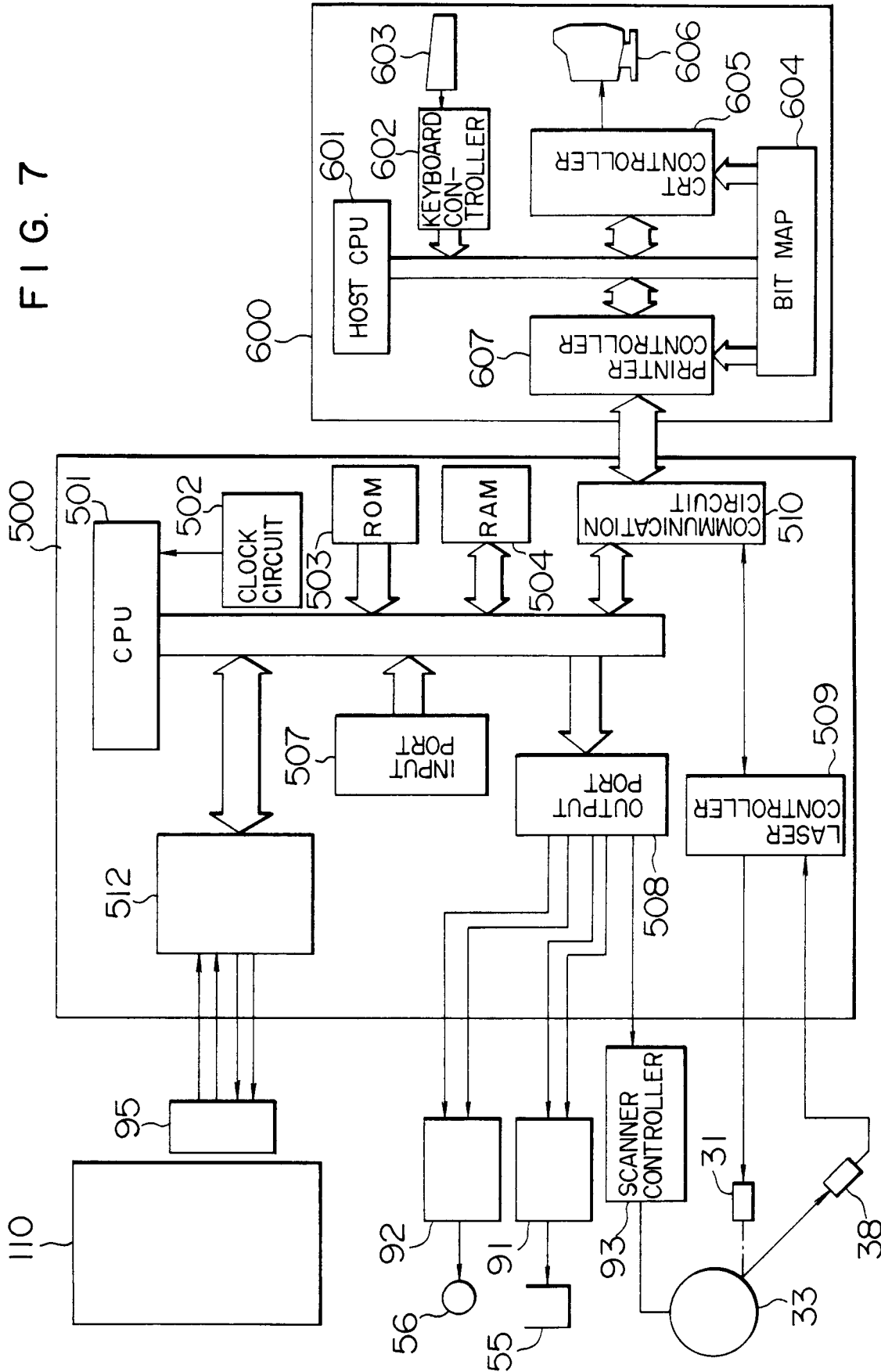

FIG. 8

