

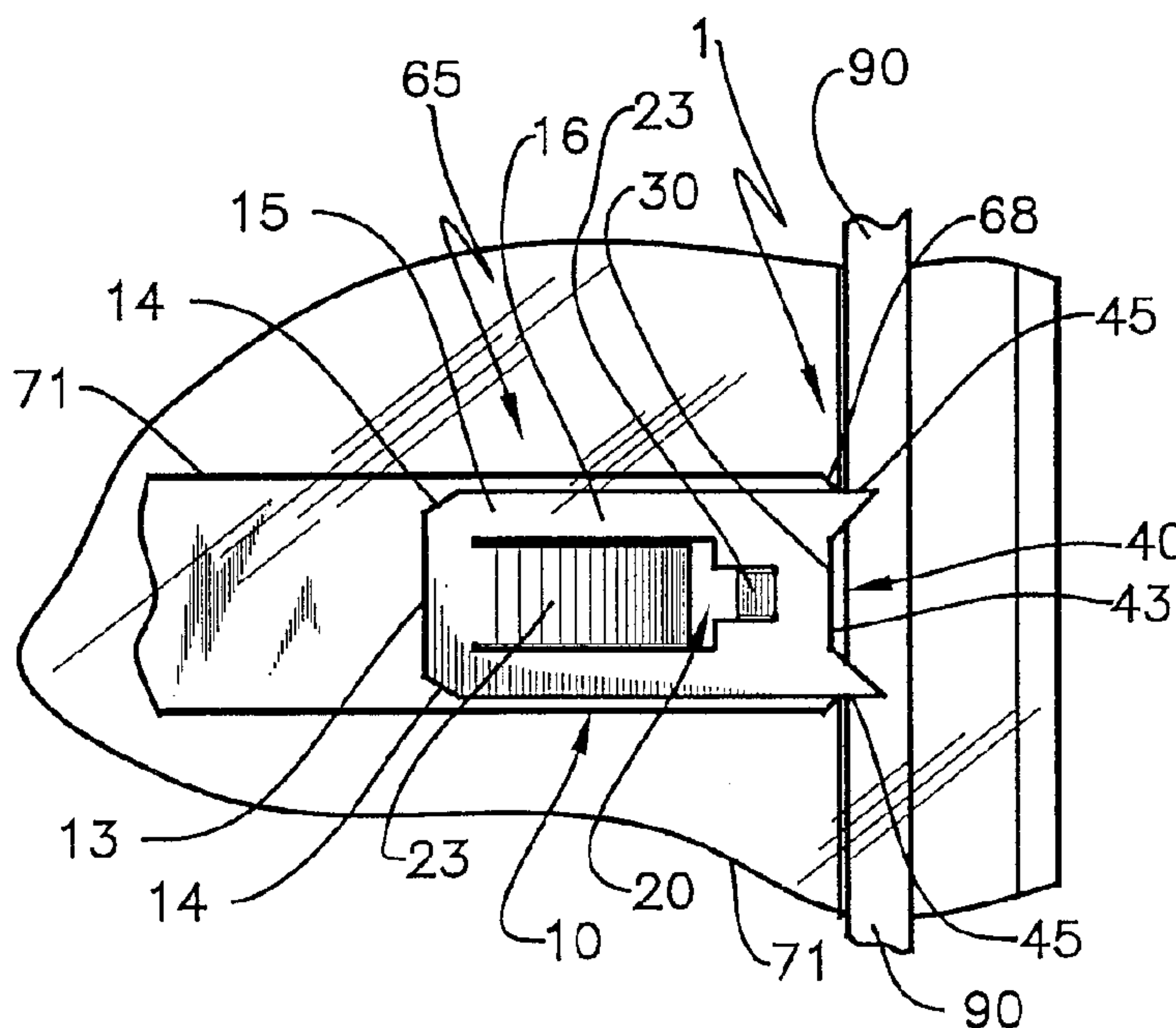

(86) Date de dépôt PCT/PCT Filing Date: 2000/01/13
 (87) Date publication PCT/PCT Publication Date: 2000/07/20
 (85) Entrée phase nationale/National Entry: 2001/07/09
 (86) N° demande PCT/PCT Application No.: US 00/01038
 (87) N° publication PCT/PCT Publication No.: WO 00/42270
 (30) Priorité/Priority: 1999/01/14 (09/231,908) US

(51) Cl.Int.⁷/Int.Cl.⁷ E04C 2/38
 (71) Demandeur/Applicant:
GIESEKE, GERALD G., US
 (72) Inventeur/Inventor:
GIESEKE, GERALD G., US
 (74) Agent: GOODWIN, SEAN W.

(54) Titre : DISPOSITIF DE RETENUE DE PETITS BOIS
 (54) Title: MUNTIN BAR CLIP



(57) **Abrégé/Abstract:**

An apparatus of a muntin bar clip (1) to secure the position of muntin bars (65) during and following the fabrication of multi-pane sealed glass window units (70). The disclosure relates to securing and positioning muntin bars (65) at multi-pane sealed glass window unit (70) perimeters and in joining hollow false muntin bars (65) within such units. The invention relates particularly to muntin bar clips (1) intended to fix the position of hollow false muntin bars (65) at the perimeter of the window unit (70) utilizing the sealing methods including foam strips (80) and or butyl (82) as the sealing medium. The disclosed invention more particularly relates to muntin bar clips (1) for the purpose of fixing the position of hollow false muntin bars (65) at the perimeter of the window unit (70) where the false muntin bar (65) is other than orthogonal in relation to the perimeter of the window. The invention more specifically provides the fixing of the position of muntin bars (65) to lessen the likelihood of either breaking or cracking the glass panes (71), as multi-pane sealed unit (70) occurs, or of causing seal failure of such units either during manufacture or following installation.



PCT

WORLD INTELLECTUAL PROPERTY ORGANIZATION
International Bureau

INTERNATIONAL APPLICATION PUBLISHED UNDER THE PATENT COOPERATION TREATY (PCT)

(51) International Patent Classification ⁷ : E04C 2/38	A1	(11) International Publication Number: WO 00/42270 (43) International Publication Date: 20 July 2000 (20.07.00)
<p>(21) International Application Number: PCT/US00/01038</p> <p>(22) International Filing Date: 13 January 2000 (13.01.00)</p> <p>(30) Priority Data: 09/231,908 14 January 1999 (14.01.99) US</p> <p>(71)(72) Applicant and Inventor: GIESEKE, Gerald, G. [US/US]; 180 Section 1 Road, P.O. Box 566, Tieton, WA 98947 (US).</p> <p>(74) Agent: IVEY, Floyd, E.; P.O. Box 6125, Kennewick, WA 99336 (US).</p>	<p>(81) Designated States: CA, European patent (AT, BE, CH, CY, DE, DK, ES, FI, FR, GB, GR, IE, IT, LU, MC, NL, PT, SE).</p> <p>Published <i>With international search report. Before the expiration of the time limit for amending the claims and to be republished in the event of the receipt of amendments.</i></p>	

(54) Title: MUNTIN BAR CLIP

(57) Abstract

An apparatus of a muntin bar clip (1) to secure the position of muntin bars (65) during and following the fabrication of multi-pane sealed glass window units (70). The disclosure relates to securing and positioning muntin bars (65) at multi-pane sealed glass window unit (70) perimeters and in joining hollow false muntin bars (65) within such units. The invention relates particularly to muntin bar clips (1) intended to fix the position of hollow false muntin bars (65) at the perimeter of the window unit (70) utilizing the sealing methods including foam strips (80) and or butyl (82) as the sealing medium. The disclosed invention more particularly relates to muntin bar clips (1) for the purpose of fixing the position of hollow false muntin bars (65) at the perimeter of the window unit (70) where the false muntin bar (65) is other than orthogonal in relation to the perimeter of the window. The invention more specifically provides the fixing of the position of muntin bars (65) to lessen the likelihood of either breaking or cracking the glass panes (71), as multi-pane sealed unit (70) occurs, or of causing seal failure of such units either during manufacture or following installation.

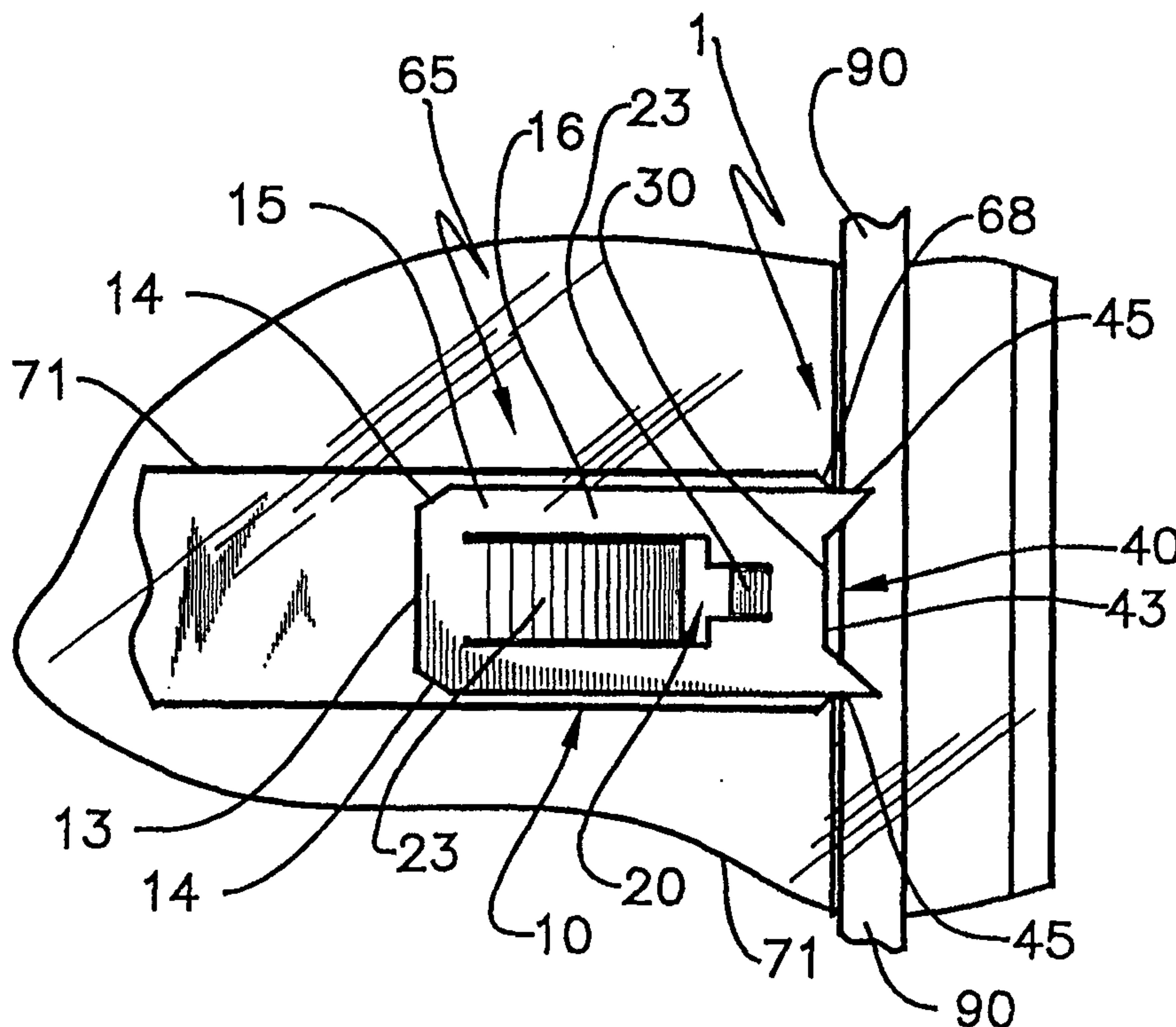

1
2
3
4
5
6
7
8
9
10
11
12
13
14
15
16
17
18
19
20
21
22
23
24
25
26
27
28
29
30

Muntin Bar Clip

Field of the Invention

The present invention relates generally to an apparatus of a muntin bar clip to secure the position of muntin bars during and following the fabrication of multi-pane sealed glass window units. The disclosure relates to securing and positioning muntin bars at multi-pane sealed glass window unit perimeters and in joining hollow false muntin bars within such units. The invention relates particularly to muntin bar clips intended to fix the position of hollow false muntin bars at the perimeter of the window unit utilizing the sealing methods including foam strips and/or butyl as the sealing medium. The disclosed invention more particularly relates to muntin bar clips for the purpose of fixing the position of hollow false muntin bars at the perimeter of the window unit where the false muntin bar is other than orthogonal in relation to the perimeter of the window. The invention more specifically provides the fixing of the position of muntin bars to lessen the likelihood of either breaking or cracking the glass panes, as multi-pane sealed unit assembly occurs, or of causing seal failure of such units either during manufacture or following installation.

Background of the Invention

Sealed multi-pane sealed window units have become standards for new and renovation construction within industrialized nations. Architectural detail is provided by the fixing of false muntin bars between panes of glass within such units. Such detail frequently requires multiple false muntin bars to intersect to form distinct patterns within the unit. The positioning of muntin bars commonly results in muntin bar ends intersecting with the perimeter of a window unit in other than an orthogonal relationship between the muntin bar and the unit perimeter forming, for example, a sunburst or radiating pattern. The securing of muntin bars in place during and following manufacture is critical in that any shifting from proper alignment will result in an unacceptable appearance. The method of or apparatus securing muntin bars, at the perimeter of such units, must not interfere with the sealing method of the unit. A method of fixing the position of muntin bars at a window unit perimeter has included the fixing of a pin at the muntin bar end with

1 the pin to be received into a hole prepared in the window unit perimeter at the frame.
2 The pin and hole combination required additional manufacturing steps and, in the case of
3 sealed units, created potential sealant breaches.

4 The advent of new manufacturing techniques and the production of foam strip
5 sealed and butyl sealed inert gas filled window units renders problematic or unusable
6 methods or apparatus, for the positioning of muntin bars, disclosed in the prior art.
7 Maintenance of gas integrity within such units is of paramount importance in insuring
8 continued heat exchange properties and eliminating the potential for formation of
9 condensation within the interior of the unit. Existing prior art is unlikely to provide for
10 the maintenance of such characteristics with a substantial likelihood that the interior of
11 sealed units will experience a breach of the seal. The apparatus disclosed herein is
12 principally adapted for use with foam strip, butyl and other similar pliable or flexible seal
13 systems.

14 Prior art which is distinguished includes the following which, along with
15 additional patents, are disclosed in an information disclosure statement. Patent 3,686,814
16 to Anderson discloses a barbed clip for use with wood frames and a clip suitable for
17 locking behind a bead on a metal window frame. Patent 4,644,721 to Bloomquist et al.
18 relates to a clip for securing a muntin bar in a single pane window for ease of removal of
19 the muntin bar for cleaning purposes. Patent No. 4,890,435 to Wilkening et al.
20 demonstrates a method of mounting muntin bars on the exterior of a multi-pane unit.
21 Patent No. 4,060,950 to Rackard et al. discloses a clip for the interconnection of muntin
22 bars at their point of crossing. Patent No. 5,574,651 to McKeegan et al. discloses a
23 keeper at the end of a muntin bar having a protrusion secured within an aperture within
24 the frame. Patent No. 3,108,336 to Tate demonstrates an end clip limited to an
25 orthogonal orientation. Patent No. 5,154,034 to Stanek shows an edge clip with a pad
26 form element in contact with the seal material causing a pressure point break of the seal
27 integrity with the window perimeter. Patent No. 3,791,095 to Martin illustrates edge
28 clips with a semi-circular edge sized to fit within one-sixteenth inch bores in the spacing
29 strips. Patent No. 5,678,376 to Poma demonstrates edge clips with protrusions received
30 into apertures in the frame. Patent No. 5,325,579 to Baier shows a multi-pane structure

1 with a muntin bar grid. Patent No. 4,437,284 to Cribben et al. shows muntin bars fixed
2 with pins at the frame. Patent No. 3,307,316 to Gray shows a pin fixing method at the
3 frame. Patent No. 4,989,384 to Kinghorn et al. illustrates a locating pin received in an
4 opening in the perimeter bar. Patent No. 3,645,058 to Jacobson discloses muntin bars
5 with cam or wedge locking with a window sash. Patent No. 3,340,661 to Krieger
6 illustrates an edge clip composed of a tongue member received into a slot and a toothed
7 member engaging a wood sash frame member. Patent No. 4,949,521 to Riegelman et al.
8 disclosed external muntin bars affixed with screw means. Patent No. 4,970,840 to
9 Ouellette et al. discloses a muntin end piece bearing a stud which snap fits into a hollow
10 of the sash. Patent No. 3,099,865 to Burnett demonstrates a magnetic pin means of
11 securing muntin bars in place. Patent No. 5,363,625 to Philippi shows a structural
12 framework having end portions fixed in place by posts received into sockets . Patents
13 No. 5,313,761 and 5,678,377 to Leopold shows an edge clip having fingers received into
14 a hollow muntin bar and secured a sash by latches received through apertures in the sash.
15 Patent No. 5,048,252 to Osborn illustrates muntin bars fixed with cam locks. Patent No.
16 3,293,817 to MacGregor shows muntin bars fixed by a stud, at the sash, received into a
17 slot in the muntin bar. The patents referred to herein are provided herewith in an
18 Information Disclosure Statement in accordance with 37 CFR 1.97.

19 Summary of the Invention

20 The present invention discloses a muntin bar clip having a post, which is received
21 into and friction secured into a hollow muntin, and a tip, distal from the post, terminating
22 in a tip end with either a blunt end or prongs. Alternative to the use of the invention with
23 the hollow muntin is the use with a hub where the muntin bar clip is received into a slot
24 or other connection means of a hub where the hub provides muntin bar connection means
25 receiving muntin bar clip means which is in turn secured into a hollow muntin. The
26 muntin bar clip disclosed herein is directed particularly to use with the multi-pane sealed
27 unit. Several methods are utilized to seal multi-pane sealed window units including the
28 use of hollow metal spacer bars having a butyl bead contacting each pane, as a primary
29 sealing means, and generally a butyl outer seal in contact with each pane and the metal
30 spacer bar separating the panes; this process may be known as a G.E.D. system. A

1 second process of sealing is the use of a solid butyl strip spaced between panes with a
2 metal strip; the butyl strip used in this process is known as a swiggle strip. A third
3 method of sealing multi-pane sealed window units is the use of an inner foam strip having
4 an outer adhesive seal; this method may be known as a super spacer. The multi-pane
5 construction is accomplished with the intent of providing a sealed unit capable of
6 maintaining the sealed integrity during manufacture through shipping, installation and
7 finally use over the years following installation.

8 Multi-pane construction generally includes positioning of muntin bars, between
9 window panes, for architectural detail. Hollow false muntin bars facilitate the formation
10 of patterns desired by the consumer. Muntin bars are interconnected within the unit, for
11 pattern formation, and positioned at the edge of the window unit with muntin bar clips.
12 The post of a muntin bar clip is received into the hollow muntin bar end which is either
13 to be joined with other muntin bars for pattern formation or which is to be positioned at
14 the window edge. Where pattern formation is to be achieved the muntin bar clip may
15 have a plurality of posts interconnected with a swivel means. Where a muntin bar is to
16 be positioned at a window unit perimeter the muntin bar clip will have a tip having a tip
17 end, distal from the post, which is received between a pane and the sealing structure or
18 sealing material separating panes in the multi-pane sealed window unit at the perimeter.
19 The prior art demonstrates a variety of means for receiving the clip into a hollow muntin
20 bar and the receipt of a tip, post or pin into a structure at the perimeter of a window unit.

21

22

Brief Description of the Drawings

23

24

25

26

The foregoing and other features and advantages of the present invention will become more readily appreciated as the same become better understood by reference to the following detailed description of the preferred embodiment of the invention when taken in conjunction with the accompanying drawings, wherein:

27

28

29

30

FIG. 1 is a perspective showing the preferred embodiment of a muntin bar clip 1 with a post 10, a post end 13 with post end bevels 14 and a post surface 15 having a first and second side 16, 17; a fastener means 20, formed at the post surface 15 from the first to the second side 16, 17, having one or a plurality of tang springs 23; a tip 40 having a

1 tip end 43 distal from the post end 13 terminating in one or a plurality of prongs 45; an
2 offset 30 formed intermediate the tip 40 and the fastener means 20.

3 FIG. 1A is a perspective of an alternative embodiment of the tip 40 of the muntin
4 bar clip 1 shown in FIG. 1 wherein the tip end 43 terminates in one prong 45.

5 FIG. 2 is a perspective of an alternative embodiment of a muntin bar clip 1 with
6 a post 10, a post end 13 with post end bevels 14 and a post surface 15 having a first and
7 second side 16, 17; a fastener means 20, formed at the post surface 15 from the first to
8 the second side 16, 17, having a dimple 26; a post second end 13' distal from the post end
9 13; a tip 40 having a tip end 43 distal from the post end 13 terminating in a blunt end
10 50; the tip 40 has a tip second end 43' distal from the tip end 43. An offset 30 formed
11 intermediate the tip 40 and the tip second end 43'. Connecting means 35 connecting the
12 post 10 and the tip 40 at the post second end 13' and the tip second end 43' such that the
13 post 10 and the tip 40 are rotatably secured by the connecting means which provides a
14 swivel function.

15 FIG. 3 is a perspective of an additional embodiment of muntin bar clip 1 of FIG.
16 2 showing the tip 40 with tip end 43 having one or a plurality of prongs 45.

17 FIG. 4 is a perspective of the muntin bar clip 1 of FIG. 2 showing a fastener
18 means 20 provided by tang springs 23.

19 FIG. 5 is a section from a side elevation showing a multi-pane sealed window
20 unit 70 having panes 71, a perimeter 72 and a hollow false muntin bar 65, shown in
21 elevation section, having an aperture 66 and end 68; a muntin bar clip 1 with a post 10,
22 a post end 13 with a post surface 15 having a first and second side 16, 17; a fastener
23 means 20, formed at the post surface 15 from the first to the second side 16, 17, having
24 one or a plurality of tang springs 23; a tip 40 having a tip end 43 distal from the post end
25 13 terminating in a blunt end 50; an offset 30 formed intermediate the tip 40 and the
26 fastener means 20. Also shown is the sealing structure 80 composed of butyl 82, and a
27 super spacer 84. The blunt end 50 is shown positioned between the pane 71 and super
28 spacer 43 at the perimeter 72.

29 FIG. 6 is a section from a side elevation showing a multi-pane sealed window unit
30 70 having panes 71, a perimeter 72 and a hollow false muntin bar 65, shown in elevation

1 section, having an aperture 66 and end 68; a muntin bar clip 1 with a post 10, a post end
2 13 with a post surface 15 having a first and second side 16, 17; a fastener means 20,
3 formed at the post surface 15 from the first to the second side 16, 17, having one or a
4 plurality of tang springs 23; a tip 40 having a tip end 43 distal from the post end 13
5 terminating in a blunt end 50; an offset 30 formed intermediate the tip 40 and the fastener
6 means 20. Also shown is the sealing structure 80 composed of swiggle strip 86. The
7 blunt end 50 is shown positioned between the pane 71 and swiggle strip 86 at the
8 perimeter 72.

9 FIG. 7 is side elevation showing a muntin bar clip 1 with a post 10, a post end
10 13 with a post surface 15 having a first and second side 16, 17; a fastener means 20,
11 formed at the post surface 15 from the first to the second side 16, 17, having one or a
12 plurality of tang springs 23; a tip 40 having a tip end 43 distal from the post end 13
13 terminating in a blunt end 50; an offset 30 formed intermediate the tip 40 and the fastener
14 means 20.

15 FIG. 8 is a section view of a muntin bar 65 showing a plan view of a muntin bar
16 clip 1. The figure illustrates the use of the invention with a sealant strip 90, composed
17 for example of a butyl bead, showing a muntin bar clip 1 with a post 10, a post end 13
18 with post end bevels 14 and a post surface 15 having a first and second side 16, 17; a
19 fastener means 20, formed at the post surface 15 from the first to the second side 16, 17,
20 having one or a plurality of tang springs 23; a tip 40 having a tip end 43 distal from the
21 post end 13 terminating in one or a plurality of prongs 45 positioned at the sealant strip
22 90; an offset 30 formed intermediate the tip 40 and the fastener means 20.

23 FIG. 9 is a section from a side elevation of the view shown in FIG. 8 showing a
24 muntin bar in elevation section and illustrating a muntin bar clip 1 positioned with sealing
25 structure 80 as butyl 82, is the sealing structure 80 composed of butyl 82 and a formed
26 spacer 88 having sealant strips 90. The tip 40 is shown positioned between the pane 71
27 and sealant strip 90 at the perimeter 72.

28 FIG. 10 is a section view of a muntin bar 65 showing a plan view of a muntin bar
29 clip 1. The figure illustrates the use of the invention with a sealing structure 80
30 comprised of butyl 82, super spacer 84 with the blunt end 50 positioned relative to super

1 spacer 84.

2 FIG. 11 is a section from a side elevation of the view shown in FIG. 10 showing
3 a muntin bar in elevation section and further illustrating the blunt end 50 positioned
4 between a pane 71 and super spacer 84.

5 FIG. 12 is a perspective of an alternative embodiment of that shown in FIG. 2
6 wherein the muntin bar clip 2 has a plurality of posts 10, 10'. The respective posts 10,
7 10' have post ends 13 with post end bevels 14 and post surfaces 15 having first and
8 second sides 16, 17; fastener means 20, formed at the post surface 15 from the first to
9 the second side 16, 17, forming dimples 26; post second ends 13' distal from the post
10 ends 13. Tip 40 having a tip end 43 distal from the post ends 13 terminating in a blunt
11 end 50; the tip 40 having a tip second end 43' distal from the tip end 43. An offset 30
12 formed intermediate the tip 40 and the tip second end 43'. Connecting means 35
13 connecting post 10, 10' and the tip 40 at the post second ends 13' and the tip second end
14 43' such that post 10, 10' and the tip 40 are rotatably secured by the connecting means
15 providing a swivel function.

16 FIG. 13 is a perspective of another embodiment of a muntin bar clip 3 having a
17 plurality of post 10, 10' and suggestive of embodiments of the invention having a
18 plurality of posts. The respective posts 10, 10' have post ends 13 with post end bevels
19 14 and post surfaces 15 having first and second sides 16, 17; fastener means 20, formed
20 at the post surface 15 from the first to the second side 16, 17, forming dimples 26; post
21 second ends 13' distal from the post ends 13. Connecting means 35 connecting post 10,
22 10' at the post second ends 13' such that post 10, 10' are rotatably secured by the
23 connecting means providing a swivel function.

24 FIG. 14 is illustrative of a multi-pane sealed window unit 70 presenting a hollow
25 false muntin bar 65 pattern permitting the use of muntin bar clip 1 as shown in FIG. 1 at
26 the first intersection 92, muntin bar clip 3 as shown in FIG. 13 at the second intersection
27 93 and muntin bar hub 51 with muntin bar clip 1, as shown in FIG. 2, at the third
28 intersection 94.

29 FIG. 15 is an elevation view of a muntin bar hub 51 having a hub 52 with a first
30 and a second edge 53, 55; one or a plurality of muntin bar connection means 58 at the

1 first edge 53 receiving muntin bar clip means 56; a slot 57 positioned at the second edge
2 55; a muntin bar clip 4 with a post 10, a post end 13 and a post surface 15; a fastener
3 means 20 at the post surface 15; a tip 40 having a tip end 43 distal from the post end 13
4 terminating in one or a plurality of prongs 45; an offset 30 formed intermediate the tip
5 40 and the fastener means 20; the post 10 at the post end 13 received into the slot 57; the
6 slot 57 positioned so that the tip 40 and one or a plurality of prongs 45 is received
7 between a pane 71 and sealing structure 80.

8 FIG. 16 is an elevation view of FIG. 15 illustrating the muntin bar hub 51 showing
9 the hub 52, first edge 53, muntin bar clip means 56; illustrated is the muntin bar clip 4
10 with tip 40 having a tip end 43 terminating in one or a plurality of prongs 45 and an
11 offset 30.

12 FIG. 17 is a section from FIG. 15 showing the muntin bar hub 51, hub 52, first
13 and second edge 53, 55, muntin bar connection means 58, muntin bar clip means 56;
14 illustrated is the muntin bar clip 4 with post 10, post end 13, post surface 15, fastener
15 means 20 at the post surface 15; an offset 30 and tip 40 having a tip end 43 terminating
16 in one or a plurality of prongs 45 which are received between a pane 71 and sealing
17 structure 80.

18 FIG. 18 is a top plan view illustrating a muntin bar hub 51 showing the hub 52,
19 first edge 53, and muntin bar connection means 58, in the form of apertures.

20 FIG. 19 is an elevation view of the muntin bar hub 51 having a hub 52 with a
21 first and a second edge 53, 55; muntin bar clip means 56; a muntin bar clip 4 with a post
22 10, a post end 13 and a post surface 15; a fastener means 20 at the post surface 15; a tip
23 40 having a tip end 43, distal from the post end 13 terminating in a blunt end 50; an
24 offset 30 formed intermediate the tip 40 and the fastener means 20; the tip 40 and blunt
25 end 50 positioned to be received between a pane 71 and sealing structure 80.

26 FIG. 20 is an elevation view of FIG. 19 illustrating the muntin bar hub 51 showing
27 the hub 52, first edge 53, muntin bar connection means 58; illustrated is the muntin bar
28 clip 4 with tip 40 having a tip end 43 terminating in a blunt end 50 and an offset 30; the
29 tip 40 positioned so that the blunt end 50 is received between a pane 71 and sealing
30 structure 80.

1 FIG. 21 is a bottom plan of the muntin bar hub 51, showing the hub 52, slots 57
2 positioned at the second edge 55; the muntin bar clip 4 with tip 40 showing the tip end
3 43 terminating in a blunt end 50.

4 FIG. 22 is a section elevation view of the muntin bar hub 51 having a hub 52 with
5 a first and a second edge 53, 55; muntin bar connection means 58 receiving muntin bar
6 clip means 56; a muntin bar clip 4 with a post 10, a post end 13 and a post surface 15; a
7 fastener means 20 at the post surface 15; a tip 40 having a tip end 43 distal from the post
8 end 13 terminating in a blunt end 50; an offset 30 formed intermediate the tip 40 and the
9 fastener means 20; the tip 40 and blunt end 50 positioned to be received between a pane
10 71 and sealing structure 80.

11 FIG. 23 is illustrative of a plan view of a muntin bar clip means 56 employed with
12 the muntin bar hub 51 embodiment.

13 FIG. 24 is illustrative of a side plan view of muntin bar clip means 56 employed
14 with the muntin bar hub 51 embodiment.

15 FIG. 25 is illustrative of a multi-pane sealed window unit 70 presenting a hollow
16 false muntin bar 65 pattern permitting the use of muntin bar clip 1 as shown in FIG 1 and
17 1A, at fourth intersection 97; muntin bar clip 1 as shown in FIG. 2, 3 and 4, at fifth
18 intersection 98; and muntin bar hub 51, hub 52 and muntin bar clip 4, as shown in FIG.
19 15 through 17, at sixth intersection 99.

20 Detailed Description

21 The prior art method of fixing of the muntin bar clip 1 in a multi-pane sealed
22 window unit 70 having a perimeter 72 includes the drilling of holes, in the structure at the
23 perimeter 72, to receive a pin. Disadvantages of this method include the precision which
24 is required in the positioning of the drilling of the hole to insure correct location of the
25 muntin bars in relation to the panes and frame. Additionally, the existence of a drilled
26 hole creates added risk of loss of sealing integrity at the perimeter. Another disadvantage
27 is the prior art frequently demonstrates clips which must be sized for each different size
28 muntin bar.

29 The preferred embodiment of the present invention seen in Fig. 1, Fig. 1A and
30 Fig. 5 through 11, is a muntin bar clip 1 with a post 10 having a post end 13 with post

1 end bevels 14 and a post surface 15 having a first and second side 16, 17; a fastener
2 means 20 formed in the post 10 at the post surface 15 from the first to the second side
3 16, 17. The fastener means 20 formed either as a tang fastener 22 having one or a
4 plurality of tang springs 23, having a spring function realized from the material from
5 which the post 10 is manufactured, formed by a cutting or stamping means of the post
6 surface 15 from the first to the second side 16, 17 or as a dimple 25 formed generally by
7 a stamping means of the post surface 15 by deforming the post surface 15 from the first
8 to the second side 16, 17 forming a dimple 26. The tang springs 23 or the dimple 26,
9 formed into a protrusion, is dimensioned to be friction received tightly into a false hollow
10 muntin bar 65, having ends 68, at the end 68. Fastener means 20 is provided by the tang
11 springs 23, dimple 26 or by other means whereby a structure formed at the post 10 will
12 provide a friction securing function when the post 10 is received into an aperture 66 of
13 a hollow false muntin bar 67 at the end 68.

14 The muntin bar clip 1 has a tip 40 having tip first and second side 41, 42 and a tip
15 end 43 distal from the post end 13. The tip end 43 may terminate in one or a plurality of
16 prongs 45, or as a blunt end 50 as shown in Figs. 1, 1A and 2 through 12. The tip end
17 43 is secured between a pane 71 and the sealing structure wherein the tip end 43 form is
18 selected such as to lessen the likelihood of breaking or cracking a pane 71 or of violating
19 the sealing structure integrity of the multi-pane construction. The tip end 43, generally
20 formed from sheet metal, is dimensioned to provide material strength sufficient to
21 maintain the position of the hollow false muntin bar 65 relative to the perimeter 72 while
22 of a thickness which will not cause breaking of the pane 71 or create a sealing structure
23 80 leak. In the preferred embodiment the tip end 43 is formed with one or more prongs
24 45, shown in Figs. 1 and 1A, which are received between the sealing structure and the
25 pane 71, in the instance of use of the G. E. D. sealing method and alternatively, where
26 other sealing systems are used such as the swiggle strip or super spacer, between the
27 sealing structure and the pane 71 and into the sealing structure material. The tip end 43
28 with prongs 45 reduce the area of a tip end 43 to be inserted between the sealing
29 structure and the pane 71, thus reducing the potential for breaking or cracking the glass
30 or violation of the seal either during manufacture or during any subsequent phase of the

1 life of a multi-pane unit. In the preferred embodiment a false hollow muntin bar 65,
2 having an end 68, receives at the end 68 the post 10, at the post end 13, of a muntin bar
3 clip 1. Post end bevels 14 facilitate the insertion of the post end 13 into the end 68. The
4 post 10 is dimensioned to be received into the false hollow muntin bar 65 at the end 68
5 such as to cause a secure friction fit in combination with the dimension of the fastener
6 means 20. The fastener means 20 is dimensioned to further insure a secure friction fit in
7 the false hollow muntin bar 65. The muntin bar clip 1 has an offset 30 formed
8 intermediate the tip 40 and the fastener means 20. The offset 30 is dimensioned to and
9 serves to center and securely position the false hollow muntin bar 65 between the panes
10 71 when the post 10 is received and secured into the false hollow muntin bar 65 end 68
11 and the tip end 43 is received between a pane 71 and the sealing structure at the
12 perimeter 72. The preferred embodiment for the muntin bar clip 1 is shown in Fig. 1 In
13 the preferred embodiment the false hollow muntin bar 65 is positioned orthogonally in
14 relation to the perimeter 72.

15 An alternative embodiment of the invention disclosed herein is shown at Fig. 2,
16 3 and 4 wherein muntin bar clip 1 is utilized for the positioning of false hollow muntin
17 bars 65 where the false hollow muntin bar 65 will be orthogonal or other than orthogonal
18 relative to the perimeter 72. Where the positioning of the false hollow muntin bar 65 will
19 be other than orthogonal relative to the perimeter 72 the post 10 will be fastened by
20 connecting means including swivel means to the tip 40. Where connecting means 35 is
21 utilized, the post 10 has a post second end 13' distal from the post end 13 and the tip 40
22 has a tip second end 43' distal from the tip end 43 and distal from the offset 30. The
23 offset 30 is intermediate the tip end 43 and the tip second end 43'. The connecting means
24 35 is positioned intermediate the post second end 13' and the fastener means 20 and the
25 tip second end 43' and the offset 30 such that the post 10 and the tip 40 are secured
26 together. The connecting means 35 may be a swivel means such that the post 10 and tip
27 40 rotate around the connecting means 35. The connecting means 35 may be a rivet
28 providing a swivel function. Where a pattern is to be formed via interconnection of false
29 hollow muntin bars 65 a plurality of posts 10 are interconnected by connecting means 35
30 including swivel means. The interconnection is positioned intermediate the fastener

1 means 20 and the post second end 13'. The fastener means 20 is intermediate the post
2 end 13 and post second end 13'. Connecting means 35 may be by swivel means.
3 Connecting means 35 may be, for example, with a rivet and may be formed during a
4 stamping process of the muntin bar clip 1.

5 Another embodiment of the disclosure is shown at Fig. 12 wherein muntin bar clip
6 2 has a plurality of posts 10, 10' affixed by connecting means to tip 40 and is utilized for
7 the positioning of more than one false hollow muntin bars 65 where the false hollow
8 muntin bars 65 will be other than orthogonal relative to the perimeter 72.

9 An additional embodiment of the disclosure is shown at Fig. 13 wherein muntin
10 bar clip 3 is utilized for the interconnection of and positioning of more than one false
11 hollow muntin bar 65 for the formation of patterns. In this embodiment a plurality of
12 posts 10, 10' having post ends and second ends 13, 13' and post surfaces 15 having a first
13 and second side 16, 17. The posts 10, 10' will be fastened together by connecting means
14 35 including swivel means proximal to the second ends 13, 13'. The connecting means
15 35 may be a rivet providing a swivel function. Fig. 13 illustrates a fastener means 20
16 formed in the posts 10, 10' at the post surfaces 15 from the first to the second sides 16,
17 17. The fastener means 20 formed having one or a plurality of tang springs 23, the tang
18 springs 23 having a spring function realized from the material from which the muntin bar
19 clip 3 is manufactured, formed by a cutting or stamping means of the post surface 15
20 from the first to the second side 16, 17, or as a dimple 26, as shown in FIG. 12, formed
21 generally by a stamping means of the post surfaces 15 by deforming the post surfaces 15
22 from the first to the second sides 16, 17. The tang springs 23 or the dimple 26, formed
23 into a protrusion, are dimensioned to be friction received tightly into the aperture 66 of
24 a false hollow muntin bar 65, having ends 68, at an end 68. Post bevels 14 may be
25 featured in any embodiment of the invention. FIG. 13 demonstrates an embodiment
26 having two posts, 10, 10'; it will be recognized that a plurality of posts may be connected
27 as required by the number of muntin bars to be interconnected.

28 FIG. 14 is illustrative of a multi-pane sealed window unit 70 presenting a hollow
29 false muntin bar 65 pattern permitting the use of muntin bar clip 3 having a plurality of
30 posts as suggested by FIG. 13, at the first, second and third intersection 92, 93 and 94..

1 Fig. 15 through 17 demonstrate the embodiment of a muntin bar hub 51 having
2 a hub 52 with a first and a second edge 53, 55; one or a plurality of muntin bar
3 connection means 58 affixed at the first edge 53. The muntin bar connection means 58,
4 in the form of an aperture, receives a muntin bar clip means 56 which is received into and
5 provides a friction fit securing the hollow false muntin bar 65 from deviating from the
6 desired orientation relative to a perimeter 72. Illustrated is a slot 57 positioned at the
7 second edge 55 receiving a muntin bar clip 4 with a post 10, a post end 13 and a post
8 surface 15; a fastener means 20 at the post surface 15; a tip 40 having a tip end 43 distal
9 from the post end 13 terminating in one or a plurality of prongs 45; an offset 30 formed
10 intermediate the tip 40 and the fastener means 20; the tip 40 and one or a plurality of
11 prongs 45 positioned to be received between a pane 71 and sealing structure 80. The
12 fastener means 20 of muntin bar clip 4 may be simply the sizing of the post 10 to insure
13 a friction fit of the post 10 as received, at the post end 13, by the slot 57. Additionally,
14 the fastener means 20 may take the form as demonstrated for muntin bar clip 1 in FIG.
15 1 or FIG. 2. It is also recognized that the tip 40 may be formed with either a blunt end
16 50 or with one or a plurality of prongs 45.

17 An additional embodiment is depicted in FIG. 18, 19, 20, 21 and 22 illustrating
18 the muntin bar hub 51 having a hub 52 with a first and a second edge 53, 55; muntin bar
19 connection means 58 receiving muntin bar clip means 56; a muntin bar clip 4 with a post
20 10, a post end 13 and a post surface 15; a fastener means 20 at the post surface 15; a tip
21 40 having a tip end 43 distal from the post end 13 terminating in a blunt end 50; an
22 offset 30 formed intermediate the tip 40 and the fastener means 20; the tip 40 and blunt
23 end 50 positioned to be received between a pane 71 and sealing structure 80. The
24 fastener means 20 of muntin bar clip 4 may be simply the sizing of the post 10 to insure
25 a friction fit of the post 10 as received, at the post end 13, by the slot 57. Additionally,
26 the fastener means 20 may take the form as demonstrated for muntin bar clip 1 in FIG.
27 1 or FIG. 2. It is also recognized that the tip 40 may be formed with either a blunt end
28 50 or with one or a plurality of prongs 45.

29 FIG. 23 and 24 illustrate muntin bar clip means 56 for use with muntin bar hub
30 51 as shown in FIG. 15 - 17 and 18 - 22.

1 FIG. 25 illustrates a multi-pane sealed window unit 70 presenting a hollow false
2 muntin bar 65 pattern permitting the use of muntin bar clip 1 as shown in FIG 1 and 1A,
3 at fourth intersection 97; muntin bar clip 1 as shown in FIG. 2, 3 and 4, at fifth
4 intersection 98; and muntin bar hub 51, as shown in FIG. 15 through 17 at sixth
5 intersection 99.

6 The muntin bar clip 1, 2, 3 or 4, as shown in FIG. 1 through 13, 15 - 17, and 19 -
7 22 may be formed from a material capable of formation by stamping or cutting including,
8 for example, sheet metal. The muntin bar clip 1 and 4, of FIG. 1 and FIG. 15-17 and 19-
9 22, including tip 40 and post 10, may be formed from a single unit of material. Muntin
10 bar clips 2 and 3 are formed from multiple units of material, including for example sheet
11 metal.

12 While a preferred embodiment of the present invention has been shown and
13 described, it will be apparent to those skilled in the art that many changes and
14 modifications may be made without departing from the invention in its broader aspects.
15 The appended claims are therefore intended to cover all such changes and modifications
16 as fall within the true spirit and scope of the invention.

17

18

19

20

21

22

23

24

25

26

27

28

29

30

1
2
3
4
5
6
7
8
9
10
11
12
13
14
15
16
17
18
19
20
21
22
23
24
25
26
27
28
29
30

I CLAIM:

1. A muntin bar clip comprising:
 - A. a post having a post end, a post surface having a first and second side, fastener means formed as a tang fastener formed in the post at the post surface from the first to the second side;
 - B. a tip having a tip end distal from the post end; an offset formed intermediate the tip and the fastener means.
2. A muntin bar clip according to claim 1 wherein:
 - A. the tip end terminates in one or a plurality of prongs.
3. A muntin bar clip according to claim 1 wherein:
 - A. the tip end terminates in a blunt end.
4. A muntin bar clip comprising:
 - A. a post having a post end, a post surface having a first and second side, fastener means formed as a dimple formed in the post at the post surface from the first to the second side;
 - B. a tip having a tip end distal from the post end; an offset formed intermediate the tip and the fastener means.
5. A window with a muntin bar clip according to claim 1 wherein said:
 - A. fastener means formed as a tang fastener having one or a plurality of tang springs; the post end has post end bevels;
 - B. the tip end terminate in one or a plurality of prongs ;
 - C. a false hollow muntin bar has an end and an aperture; the aperture receives at the end the post, at the post end;
 - D. a multi-pane sealed window unit having panes and a perimeter; a sealing structure at the perimeter; hollow false muntin bars received between the panes; the tip end is dimensioned to be secured between a pane and into the sealing structure;
 - E. the offset is dimensioned to center and securely position the false hollow

- 1 muntin bar between the panes when the post is received and secured into
2 the false hollow muntin bar aperture at an end and the tip end is received
3 between a pane and into the sealing structure at the perimeter.
- 4 6. A window with a muntin bar clip according to claim 4 wherein said:
- 5 A. the post end has post end bevels
6 B. the tip end terminates in a blunt end;
7 C. a false hollow muntin bar has an end and an aperture; the aperture
8 receives at the end the post, at the post end;
9 D. a multi-pane sealed window unit having panes and a perimeter; a sealing
10 structure at the perimeter; hollow false muntin bars received between the
11 panes; the tip end is dimensioned to be secured between a pane and into
12 the sealing structure;
13 E. the offset is dimensioned to center and securely position the false hollow
14 muntin bar between the panes when the post is received and secured into
15 the false hollow muntin bar aperture at an end and the tip end is received
16 between a pane and into the sealing structure at the perimeter.
- 17 7. The muntin bar clip of claim 5 wherein:
- 18 A. the tang springs have a spring function.
- 19 8. A muntin bar clip comprising:
- 20 A. a post having a post end and a post second end distal from the post end
21 ; fastener means formed as a tang fastener formed in the post at a post
22 surface from the first to the second side intermediate the post end and
23 post second end;
24 B. a tip has a tip end and a tip second end distal from the tip end ; the tip
25 having an offset intermediate the tip end and tip second end ;
26 C. connecting means is positioned intermediate the post second end and the
27 fastener means and the tip second end and the offset such that the post
28 and the tip are rotatably secured.
- 29 9. A muntin bar clip of claim 8 where the connecting means is a swivel means; the
30 tip end terminates in one or a plurality of prongs.

- 1 10. A muntin bar clip of claim 8 where the connecting means is a swivel means; the
2 tip end terminates in a blunt end.
- 3 11. A window with a muntin bar clip comprising:
- 4 A. a plurality of posts each having a post end and a post second end distal
5 from the post end ; fastener means formed as at least one tang fastener
6 having a spring function in each post at a post surface from a first to a
7 second side intermediate the post end and post second end ;
- 8 B. a tip has a tip end and a tip second end distal from the tip end ; the tip
9 having an offset intermediate the tip end and tip second end ;
- 10 C. connecting means is positioned intermediate each post second end and
11 the fastener means and the tip second end and the offset such that the
12 plurality of posts and the tip are rotatably secured;
- 13 D. a false hollow muntin bar has an end and an aperture; the aperture
14 receives at the end the post, at the post end;
- 15 E. a multi-pane sealed window unit having panes and a perimeter ; a sealing
16 structure at the perimeter ; hollow false muntin bars received between the
17 panes ; the tip end is dimensioned to be secured between a pane and into
18 the sealing structure;
- 19 F. the offset is dimensioned to center and securely position the false hollow
20 muntin bar between the panes when the post is received and secured
21 into the false hollow muntin bar aperture at an end and the tip end is
22 received between a pane and into the sealing structure at the perimeter.
- 23
- 24 12. A window with a muntin bar clip comprising:
- 25 A. a plurality of posts each having a post end and a post second end distal
26 from the post end ; the fastener means formed as a dimple in each post
27 at a post surface from a first to a second side intermediate the post end
28 and post second end into a protrusion dimensioned to be friction received
29 tightly into an aperture of a false hollow muntin bar , having ends , at an
30 end;

- 1 B. a tip has a tip end and a tip second end distal from the tip end ; the tip
2 having an offset intermediate the tip end and tip second end ;
- 3 C. connecting means is positioned intermediate each post second end and
4 the fastener means and the tip second end and the offset such that the
5 plurality of posts and the tip are rotatably secured;
- 6 D. a false hollow muntin bar has an end and an aperture ; the aperture
7 receives at the end the post , at the post end ;
- 8 E. a multi-pane sealed window unit having panes and a perimeter ; a sealing
9 structure at the perimeter ; hollow false muntin bars received between the
10 panes ; the tip end is dimensioned to be secured between a pane and into
11 the sealing structure;
- 12 F. the offset is dimensioned to center and securely position the false hollow
13 muntin bar between the panes when the post is received and secured
14 into the false hollow muntin bar aperture at an end and the tip end is
15 received between a pane and into the sealing structure at the perimeter.
16
- 17 13. A muntin bar clip comprising:
- 18 A. a plurality of posts each having a post end and a post second end distal
19 from the post end ; fastener means formed as a tang fastener formed in
20 each post at a post surface from a first to a second side intermediate the
21 post end and post second end ;
- 22 B. connecting means is positioned intermediate each post second end and
23 the fastener means such that the plurality of posts are rotatably secured.
- 24 14. A method of using the muntin bar clip of claim 2 comprising the steps of:
- 25 A. inserting the fastener means into a muntin bar;
- 26 B. positioning the prongs so that the tip end is received between a pane
27 and into a sealing structure of a multi-pane sealed window unit .
- 28 15. A method of using the muntin bar clip of claim 16 comprising the steps of:
- 29 A. inserting the fastener means into a muntin bar;
- 30 B. positioning the prongs so that the tip end is received between a pane and

- 1 into a sealing structure of a multi-pane sealed window unit .
- 2
- 3 16. A muntin bar clip according to claim 4 wherein:
- 4 A. the tip end terminates in one or a plurality of prongs .
- 5 17. A muntin bar clip according to claim 4 wherein:
- 6 A. the tip end terminates in a blunt end.
- 7 18. A muntin bar clip comprising:
- 8 A. a plurality of posts each having a post end and a post second end distal
- 9 from the post end; fastener means formed as a dimple formed in each post
- 10 at a post surface from a first to a second side intermediate the post end
- 11 and post second end;
- 12 B. connecting means is positioned intermediate each post second end and the
- 13 fastener means such that the plurality of posts are rotatably secured.
- 14 19. A muntin bar clip comprising:
- 15 A. a post having a post end and a post second end distal from the post end;
- 16 fastener means formed as a dimple formed in the post at a post surface
- 17 from the first to the second side intermediate the post end and post
- 18 second end;
- 19 B. a tip has a tip end and a tip second end distal from the tip end; the tip
- 20 having an offset intermediate the tip end and tip second end;
- 21 C. connecting means is positioned intermediate the post second end and the
- 22 fastener means and the tip second end and the offset such that the post
- 23 and the tip are rotatably secured.
- 24 20. A muntin bar clip of claim 19 where the connecting means is a swivel means; the
- 25 tip end terminates in one or a plurality of prongs.
- 26 21. A muntin bar clip of claim 19 where the connecting means is a swivel means; the
- 27 tip end terminates in a blunt end.
- 28 22. A method of using a muntin bar clip with prongs in combination with a multi-pane
- 29 window that has a sealing structure between the panes comprising the steps of:
- 30

1 A. positioning the muntin bar clip whereby the prongs are received between
2 a pane and into a sealing structure of a multi-pane sealed window unit.
3
4
5
6
7
8
9
10
11
12
13
14
15
16
17
18
19
20
21
22
23
24
25
26
27
28
29
30

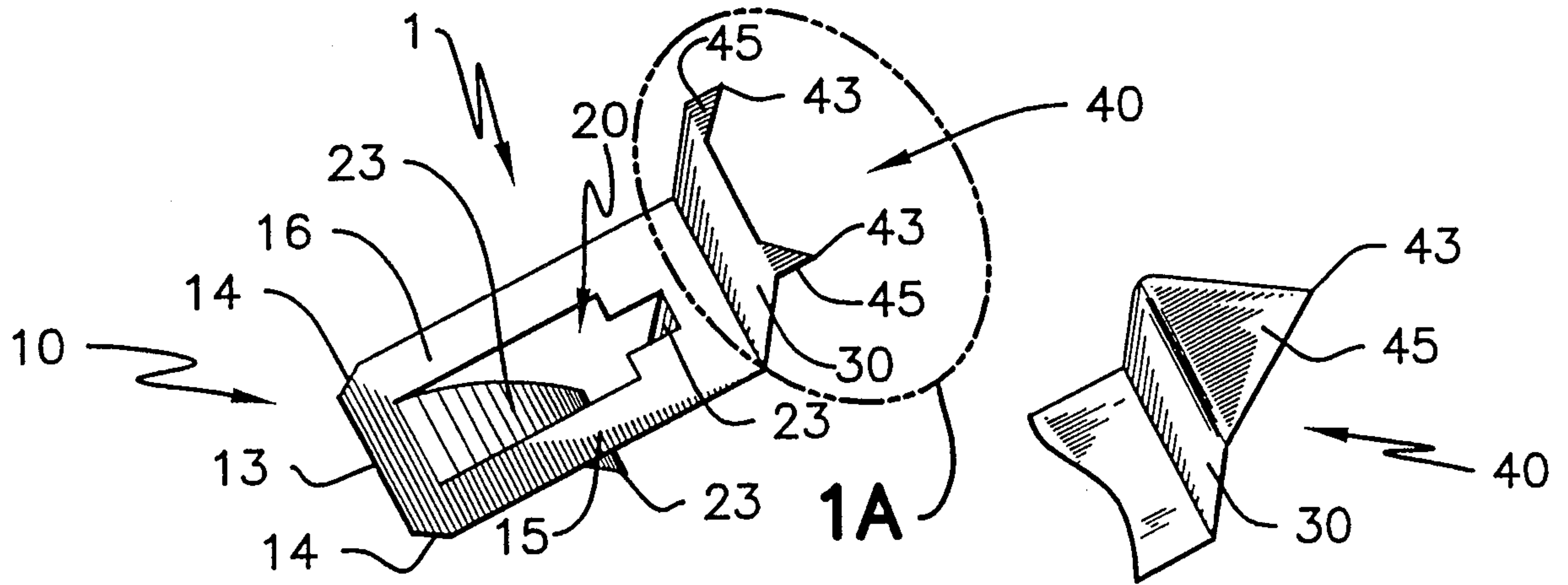

Fig. 1

Fig. 1A

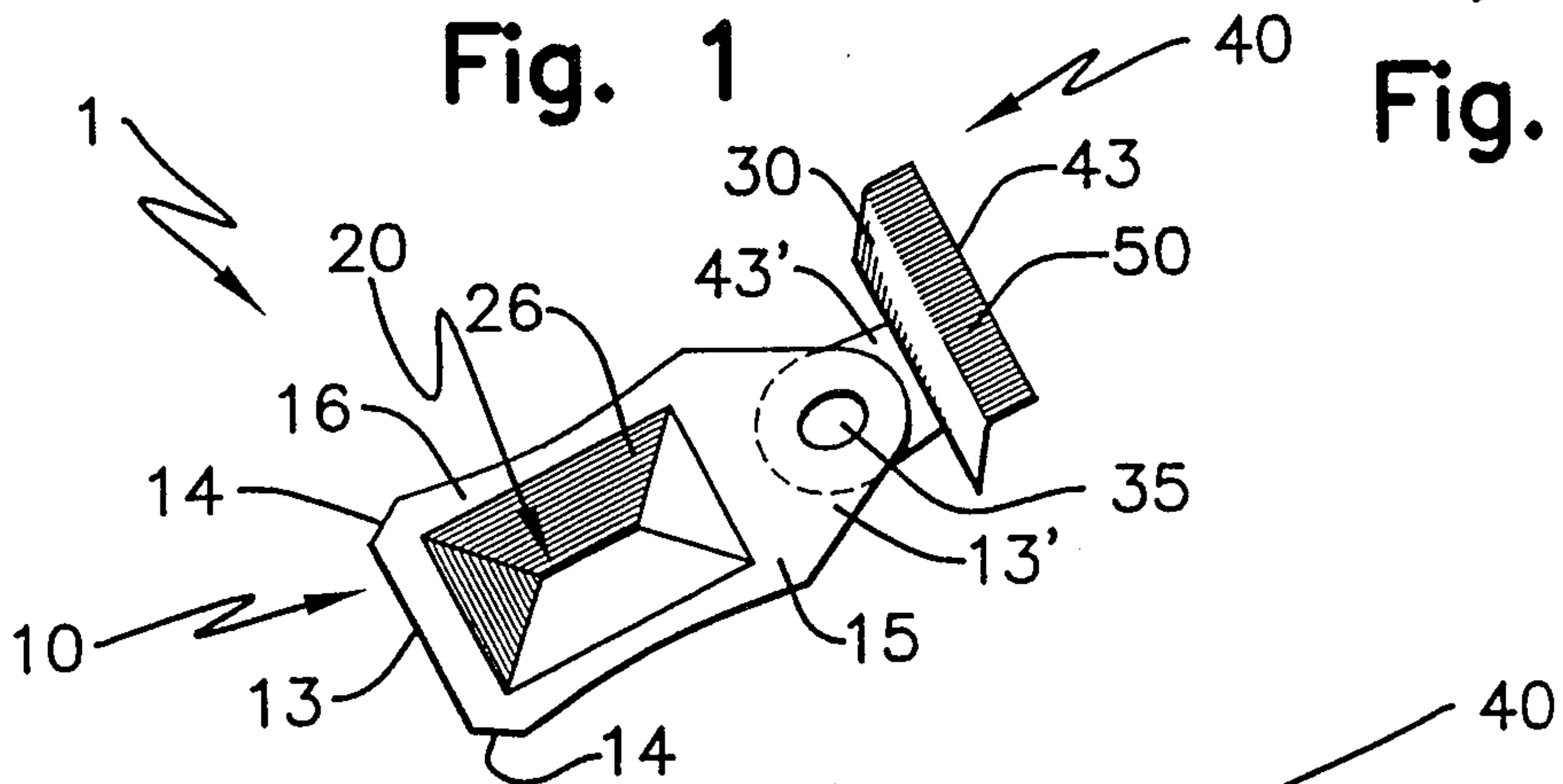

Fig. 2

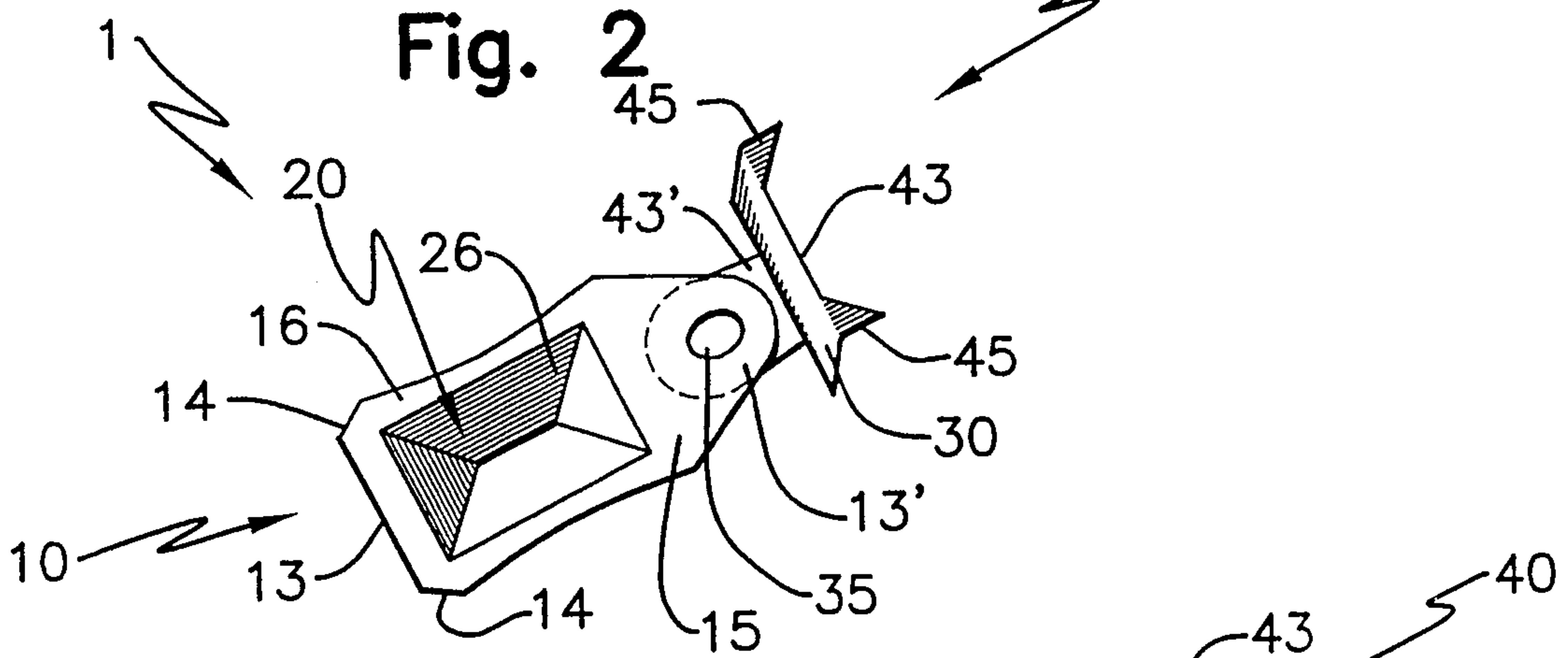

Fig. 3

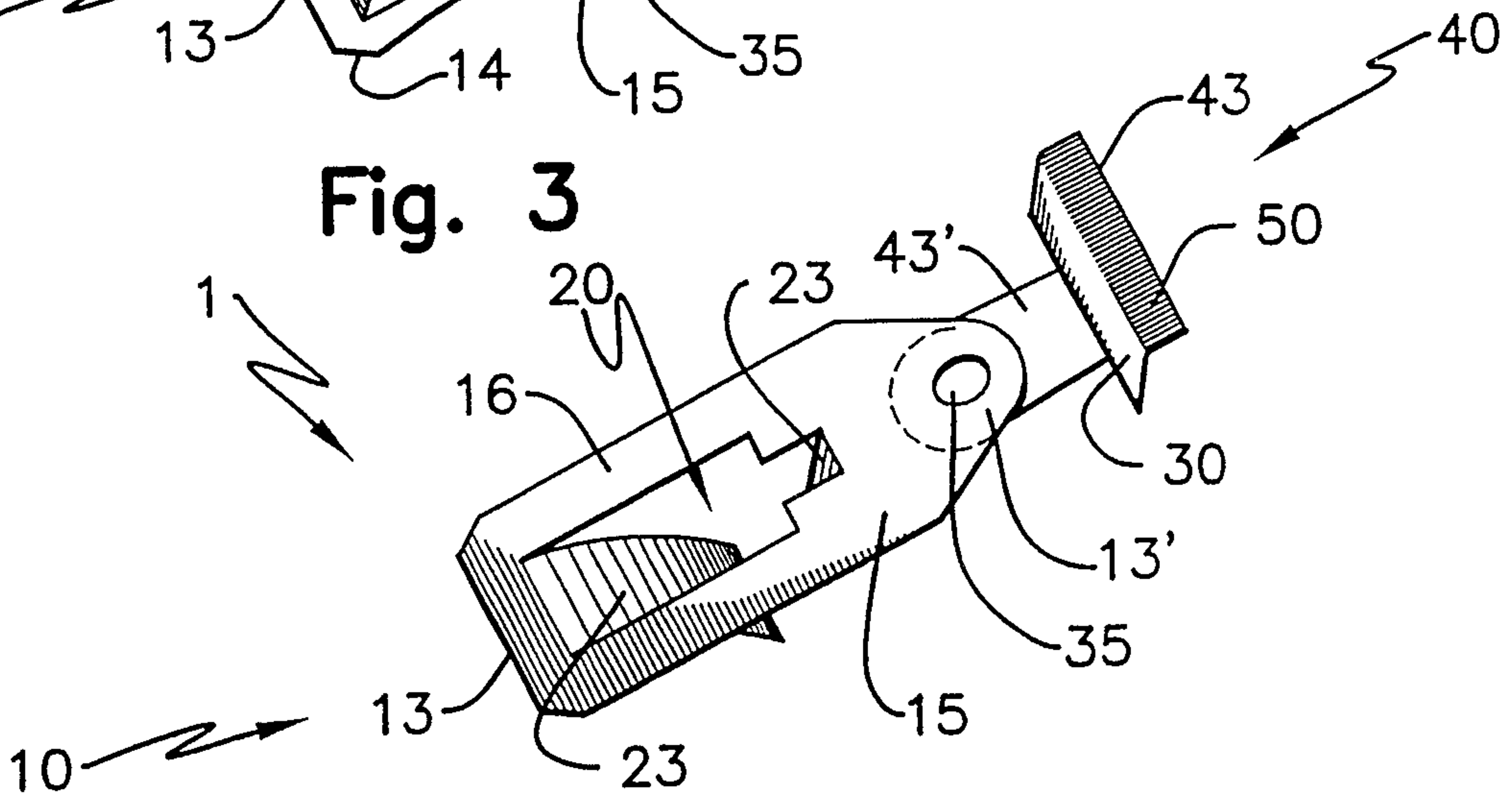

Fig. 4

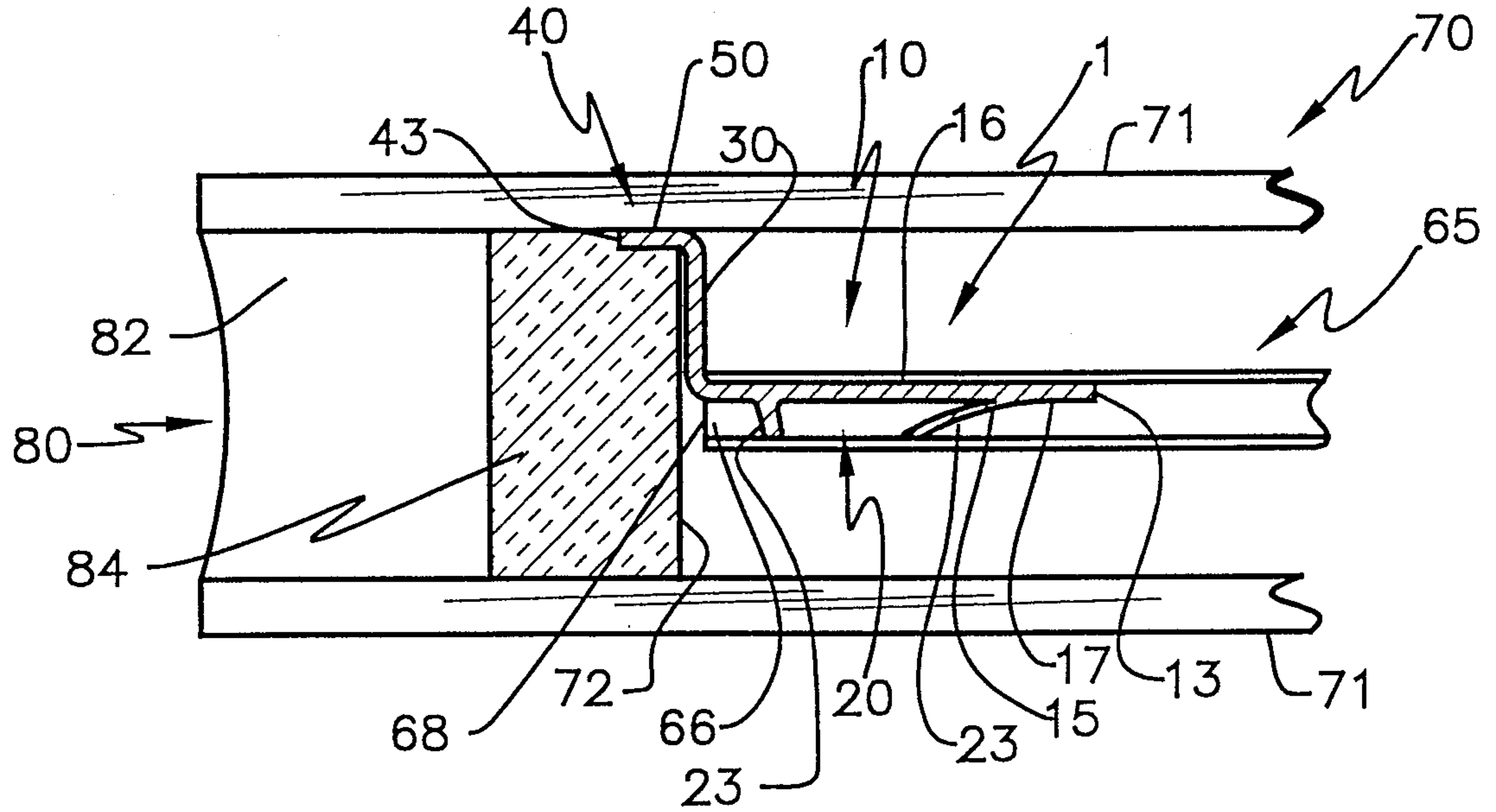

Fig. 5

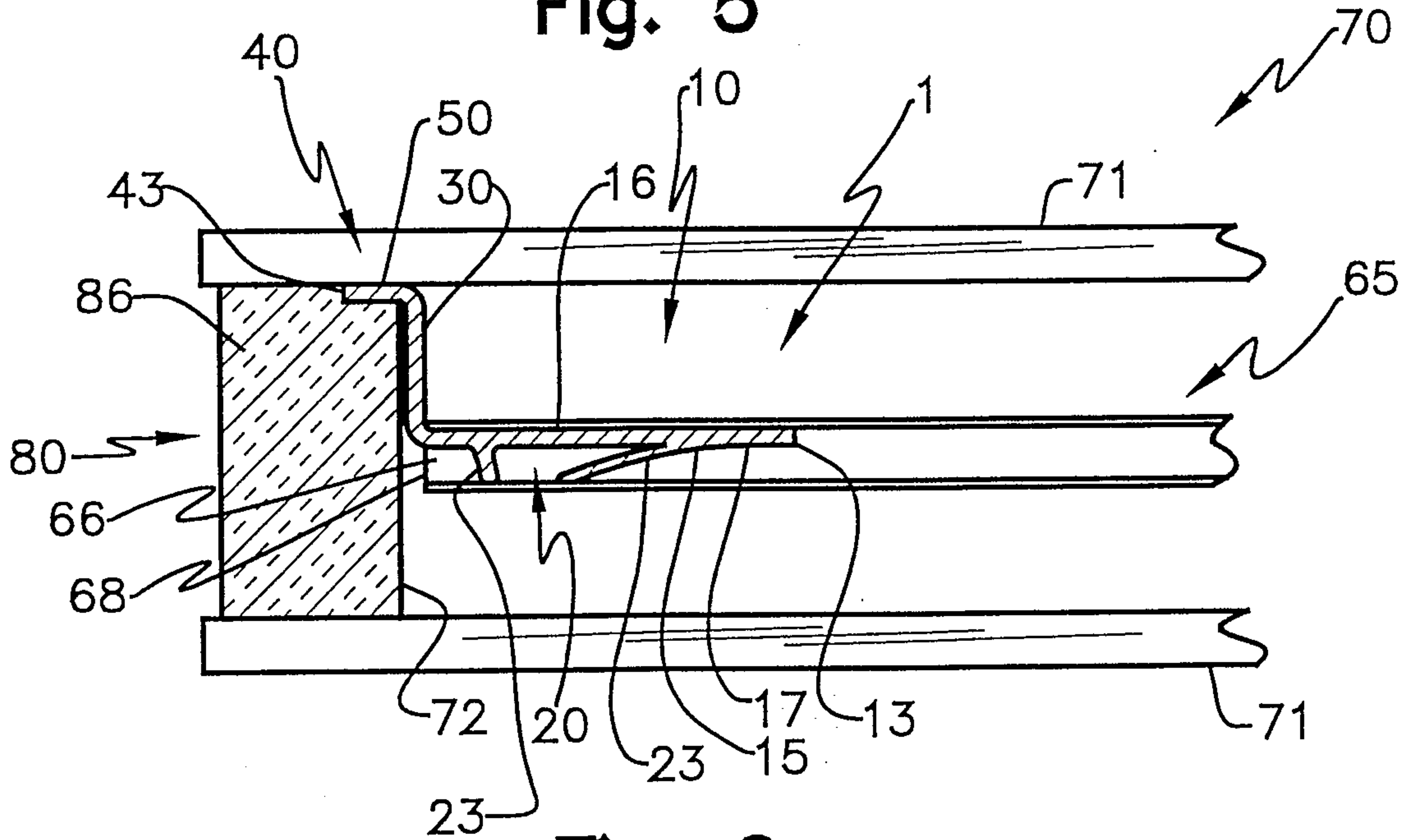

Fig. 6

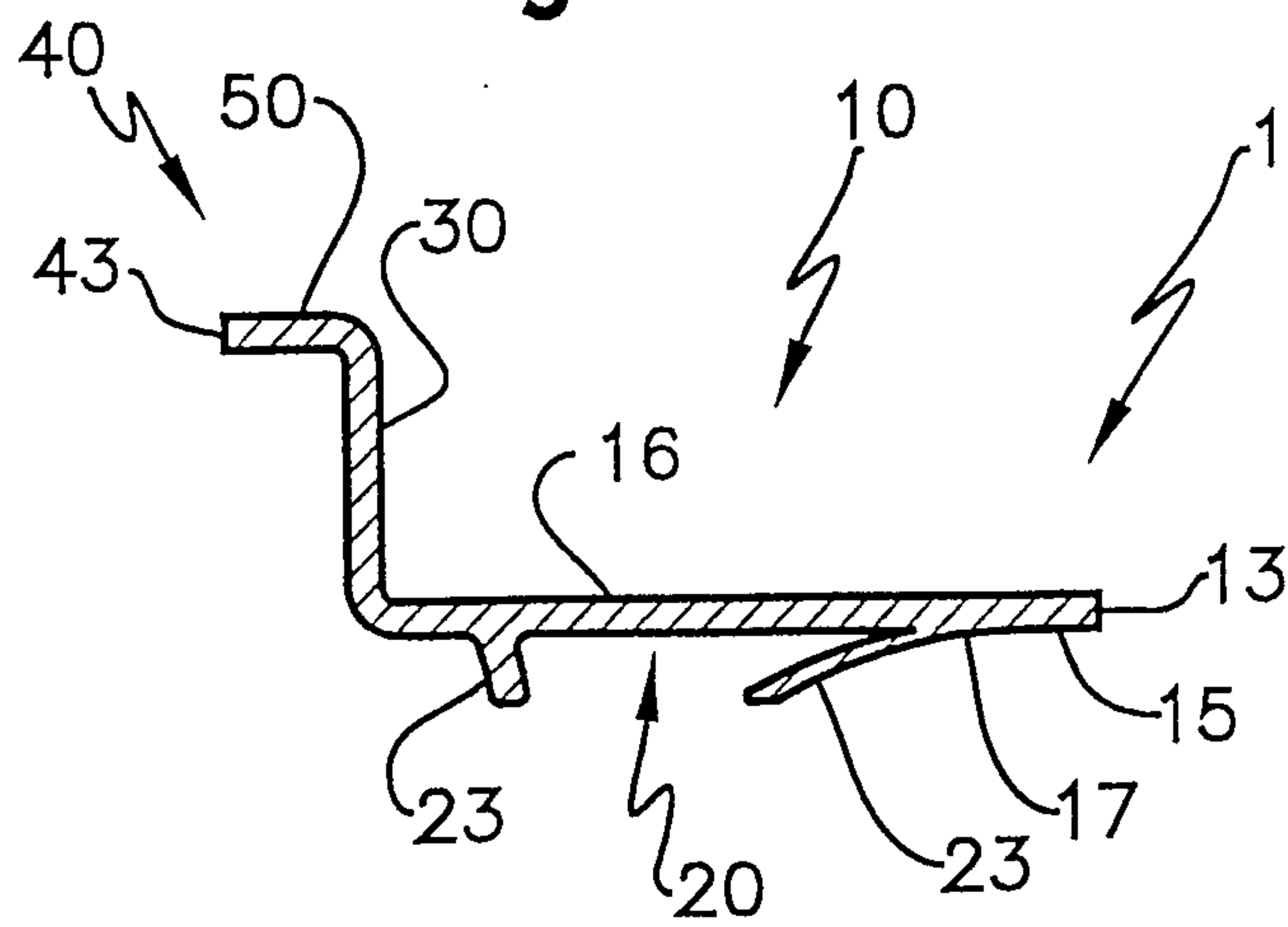

Fig. 7

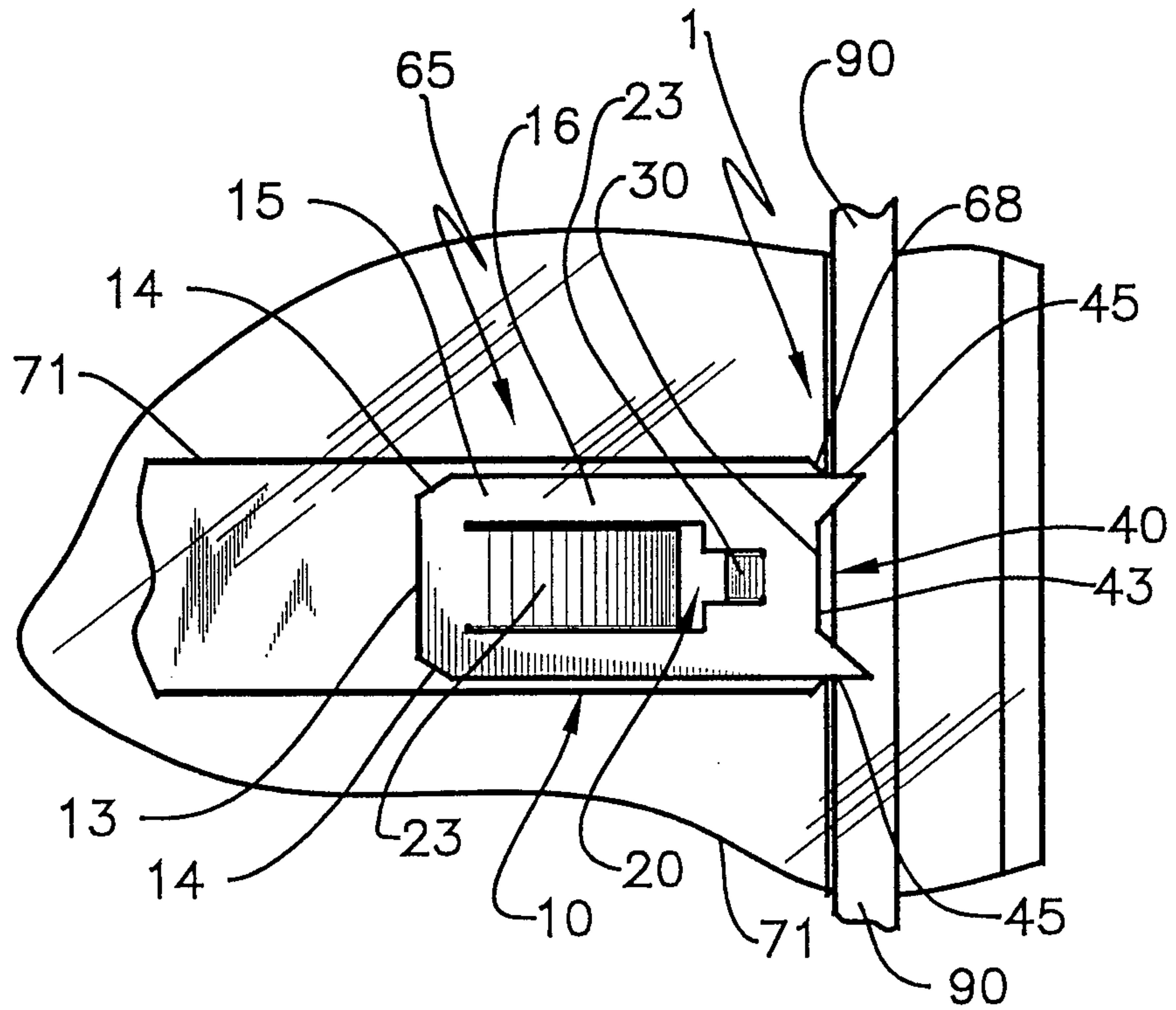

Fig. 8

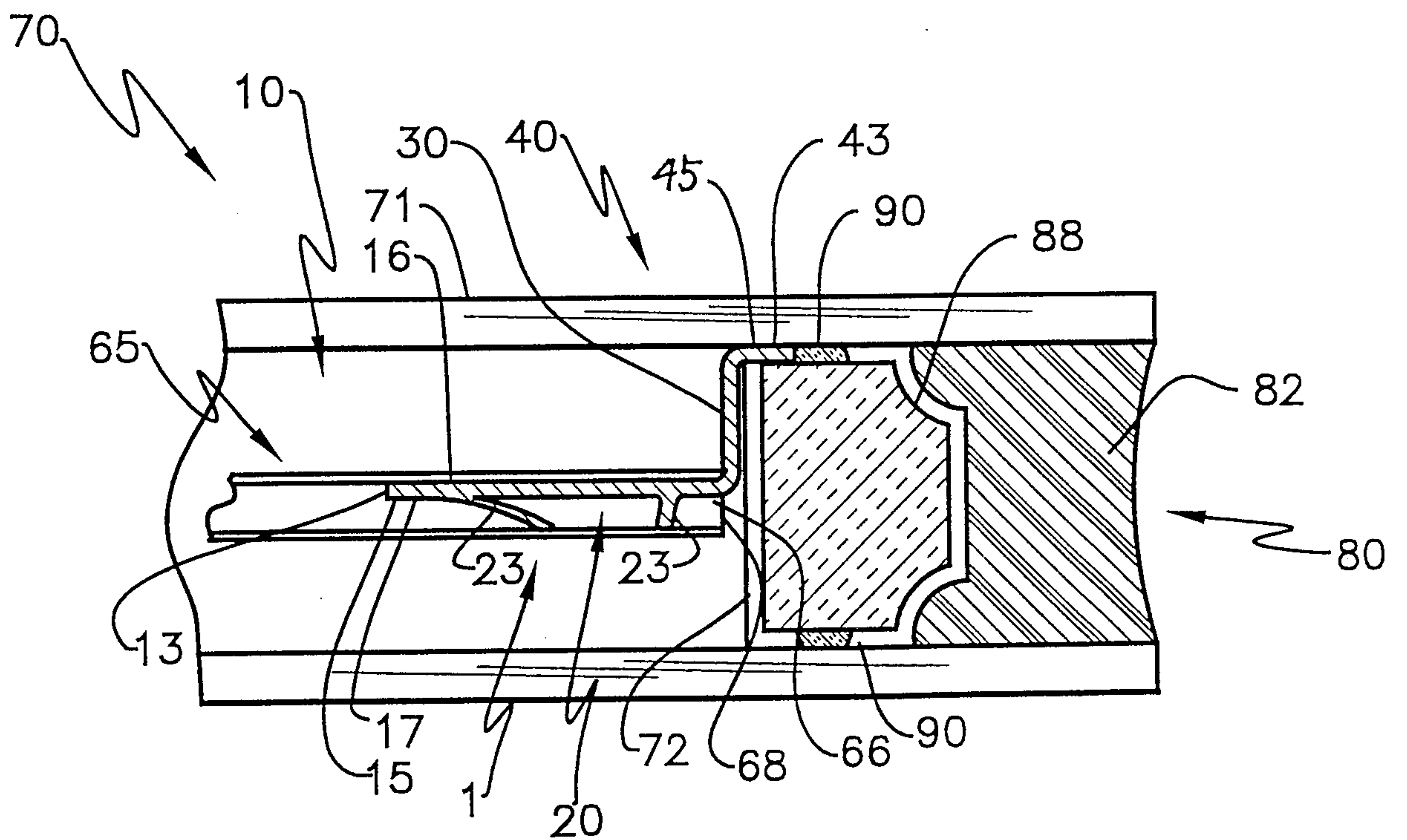

Fig. 9

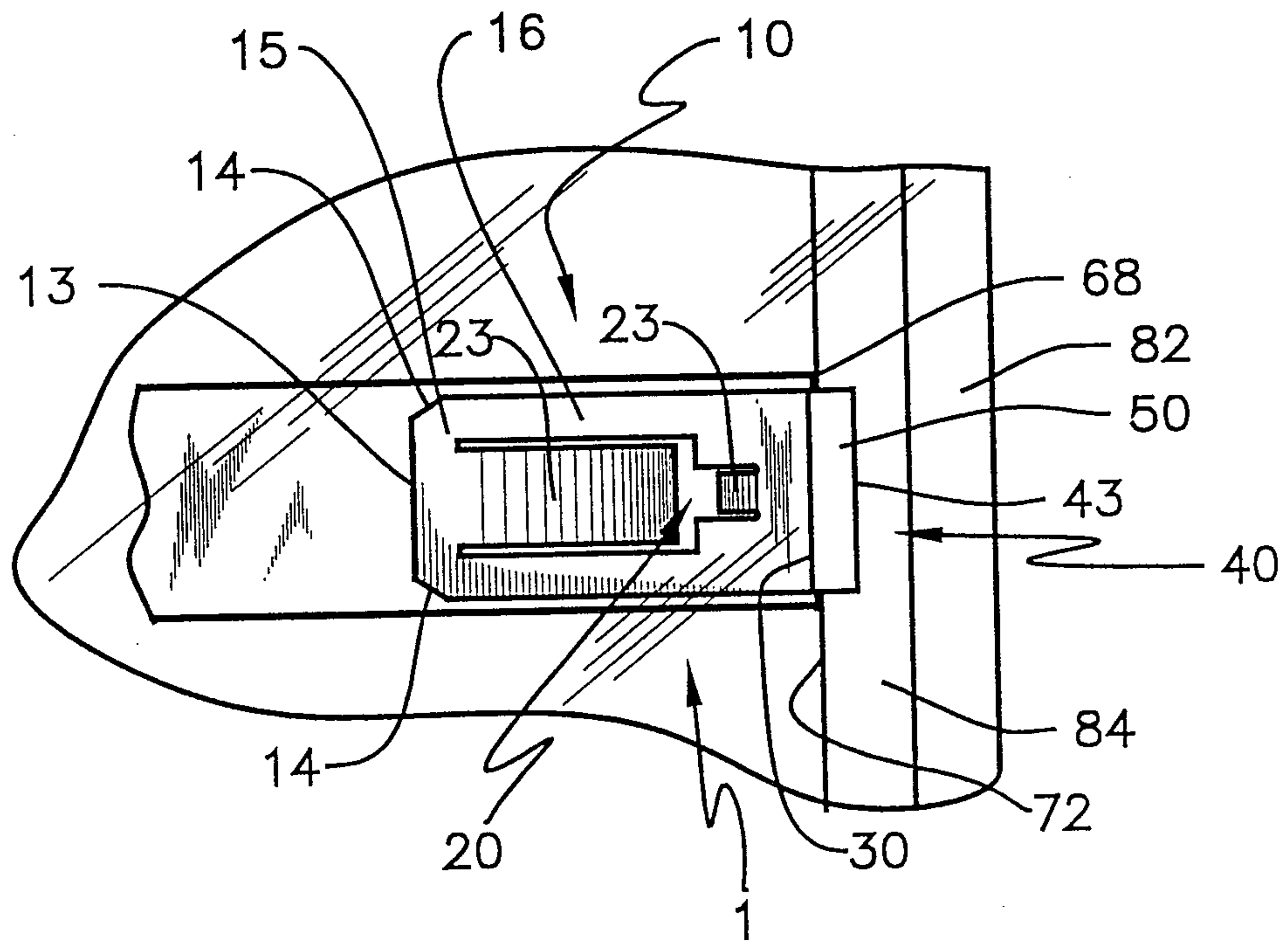

Fig. 10

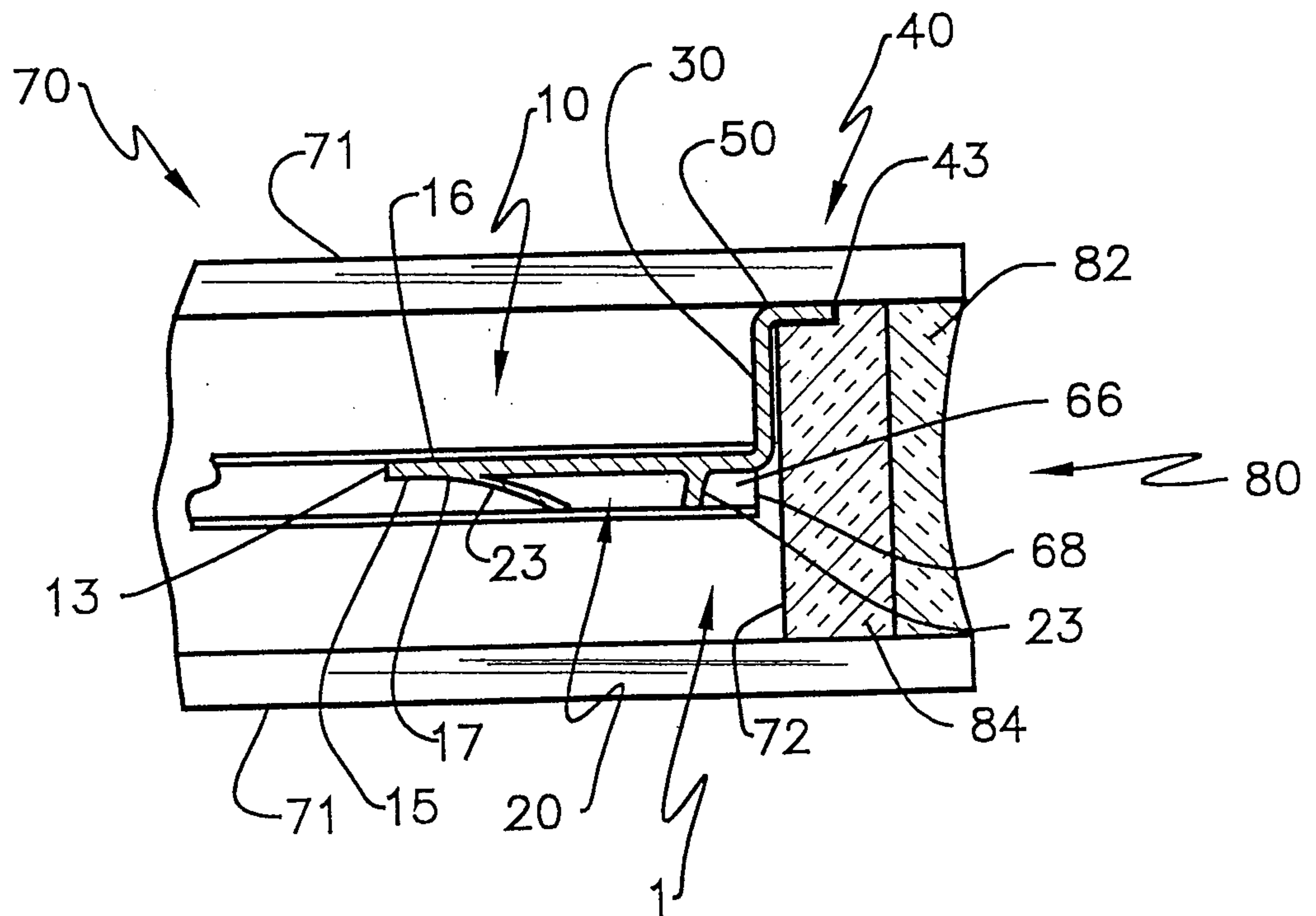

Fig. 11

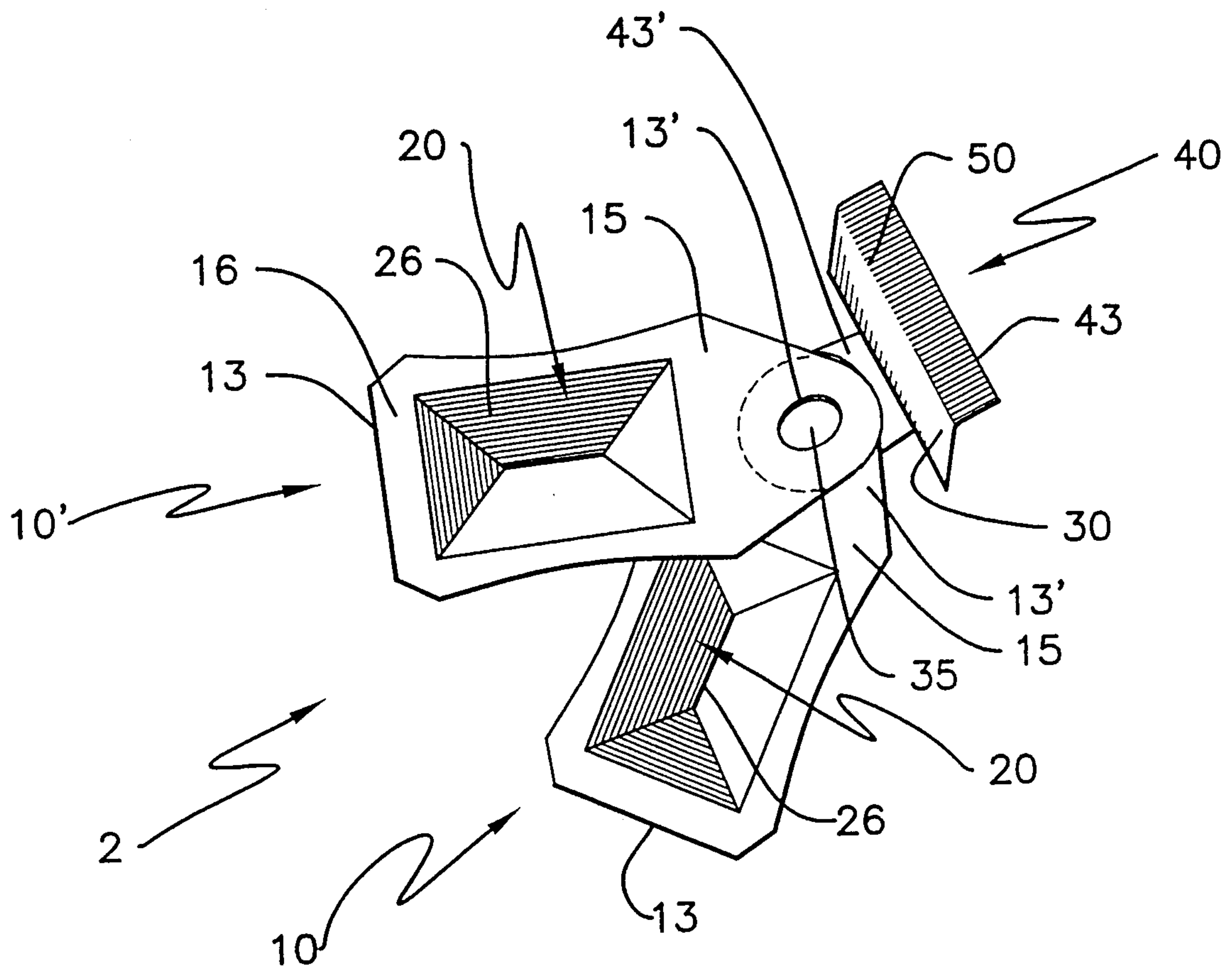

Fig. 12

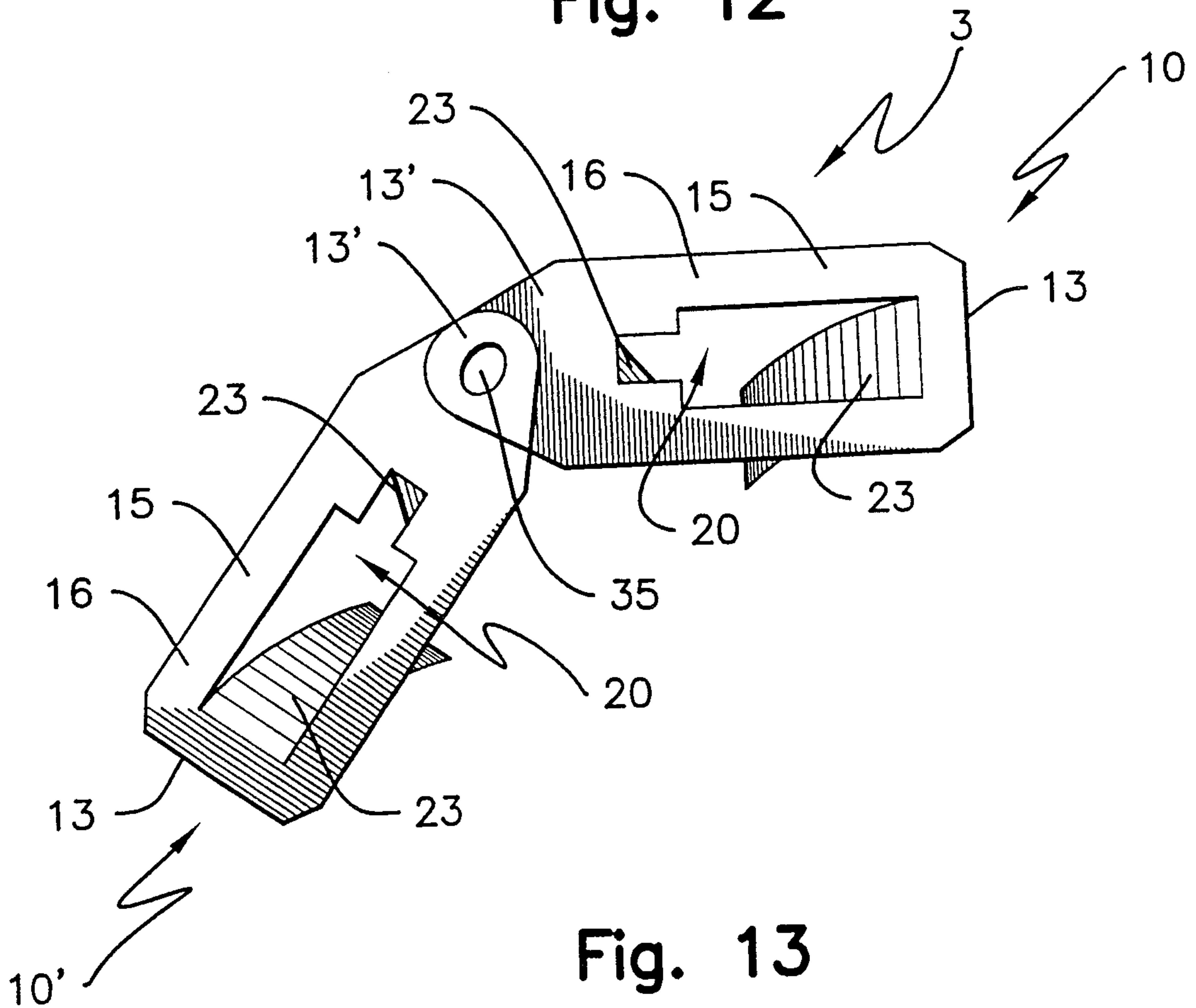

Fig. 13

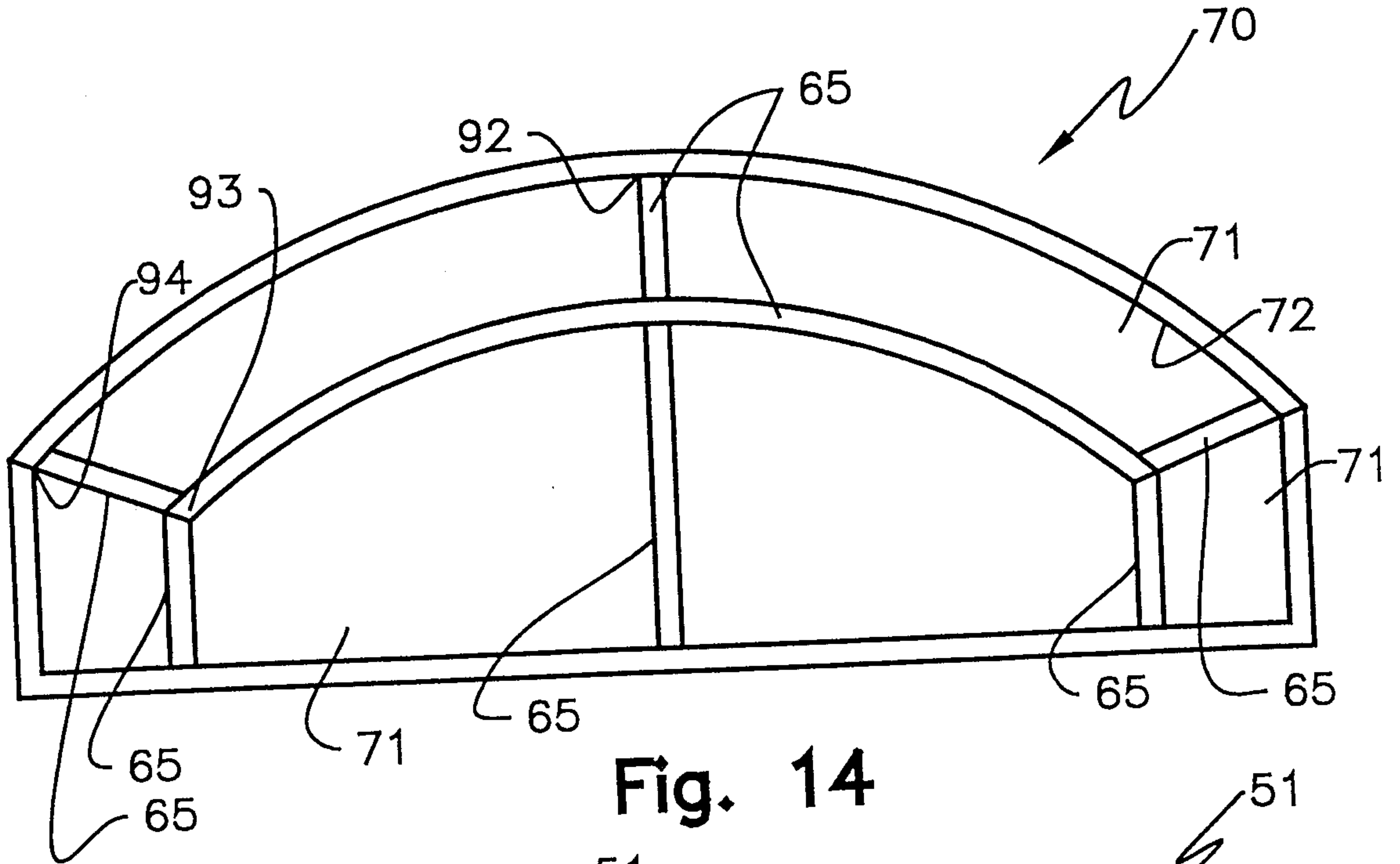

Fig. 14

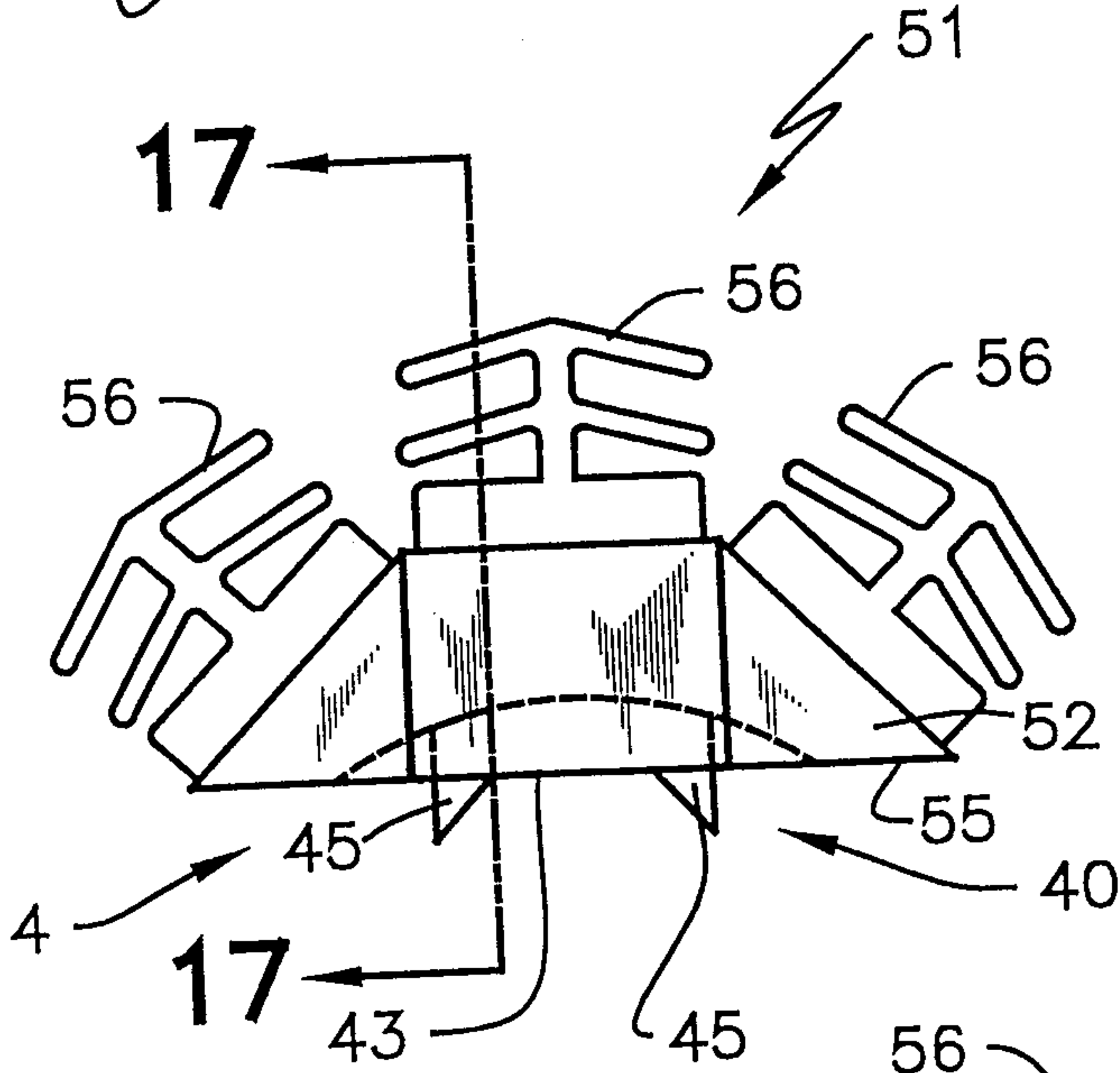

Fig. 15

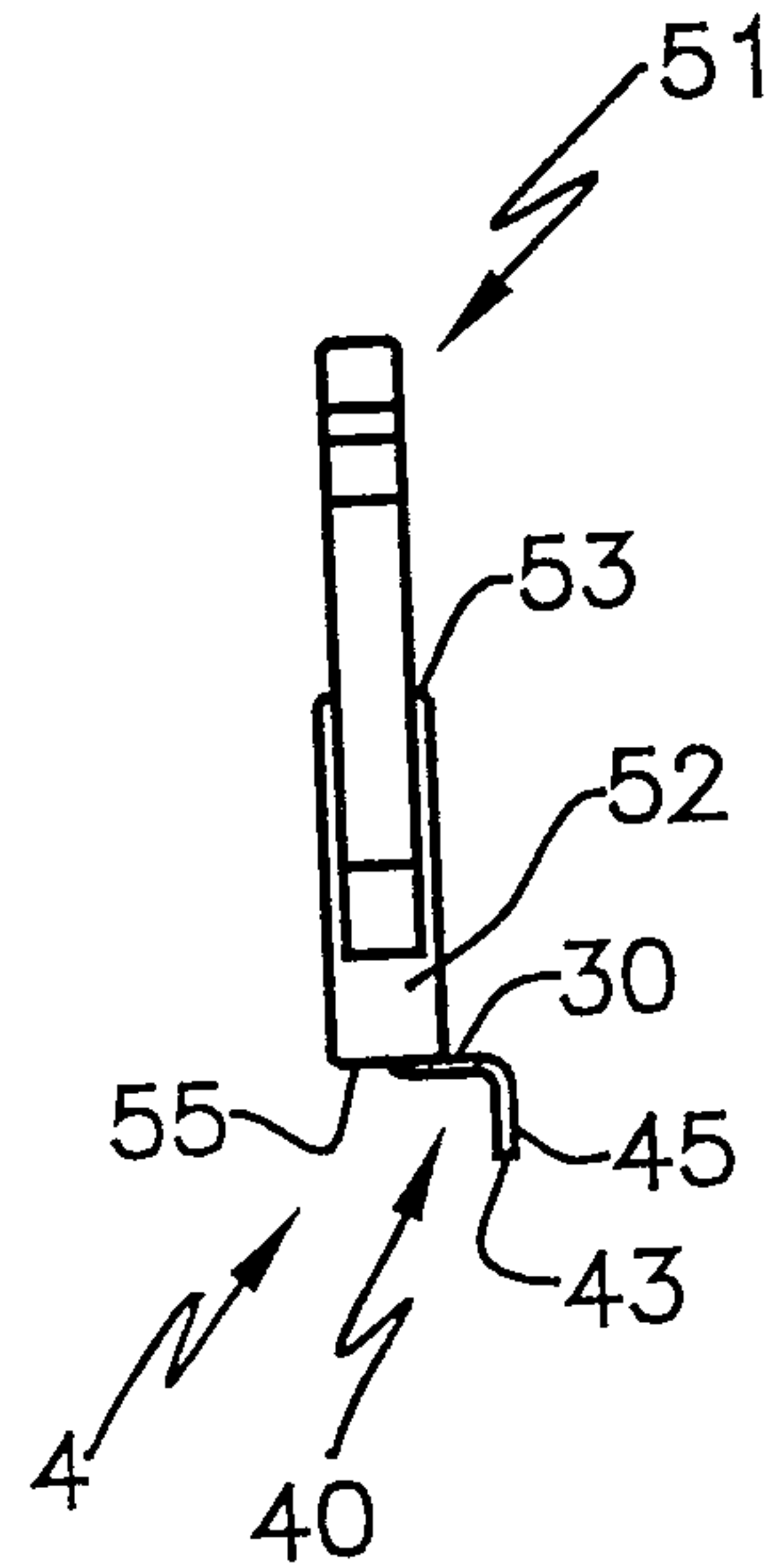

Fig. 16

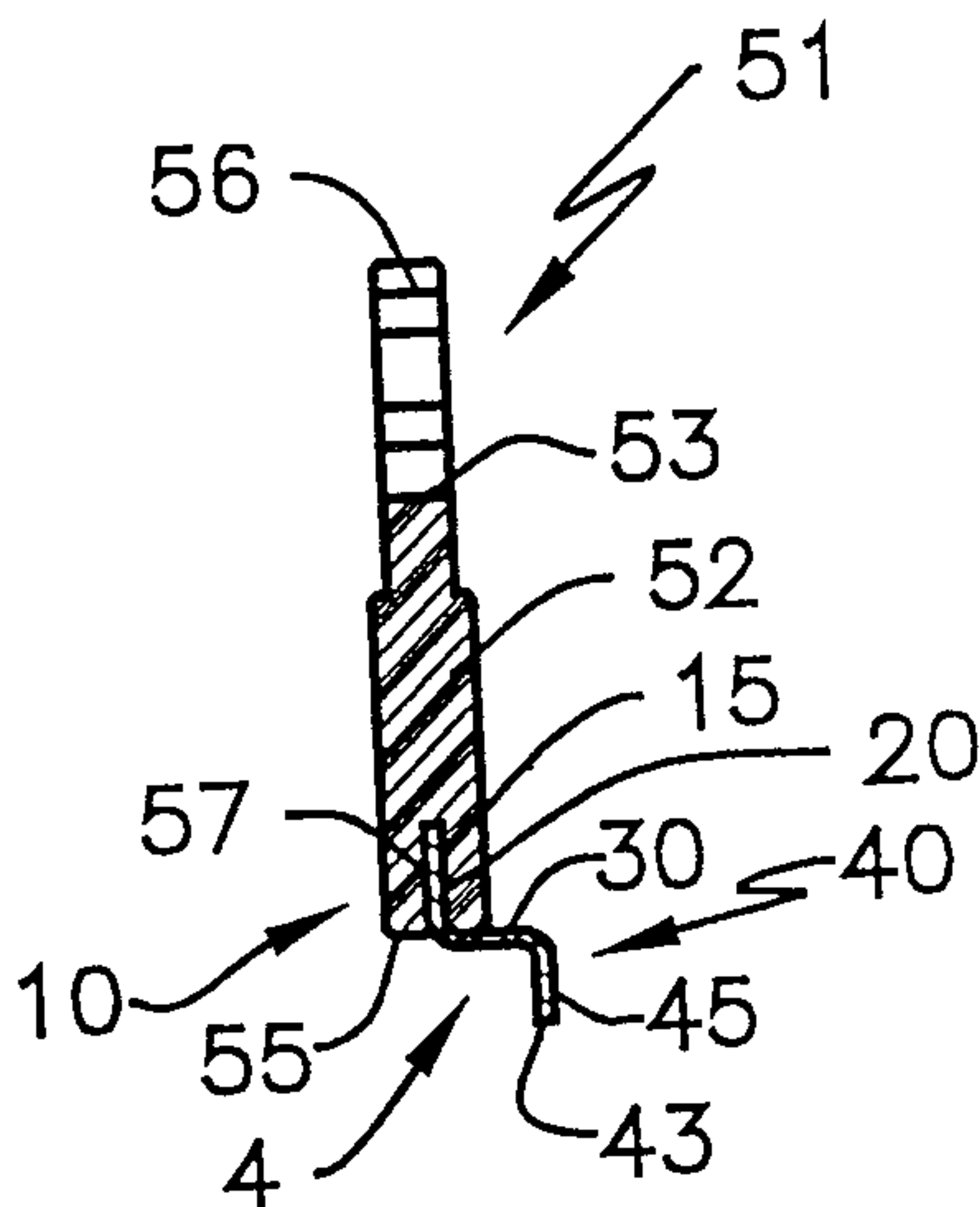
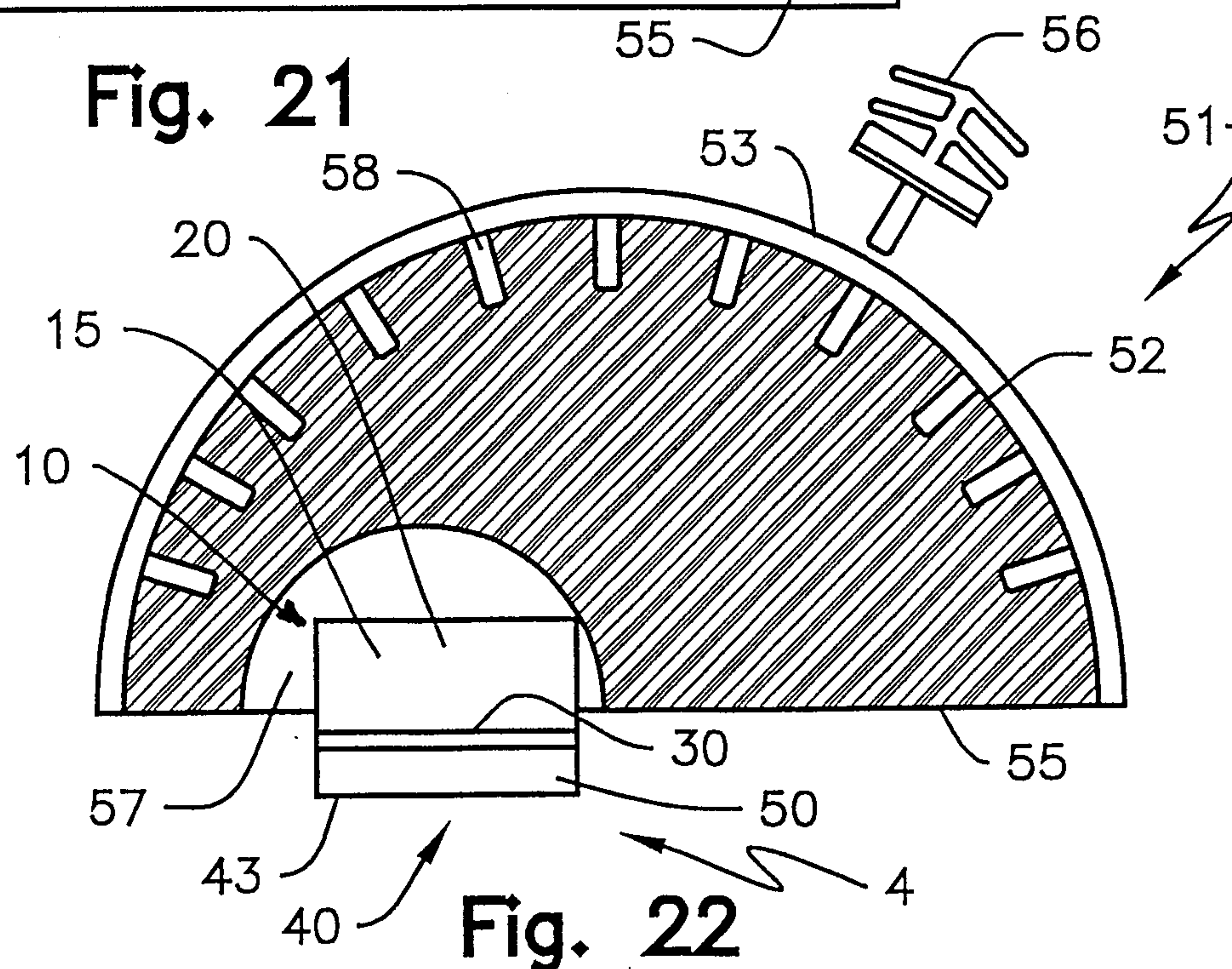
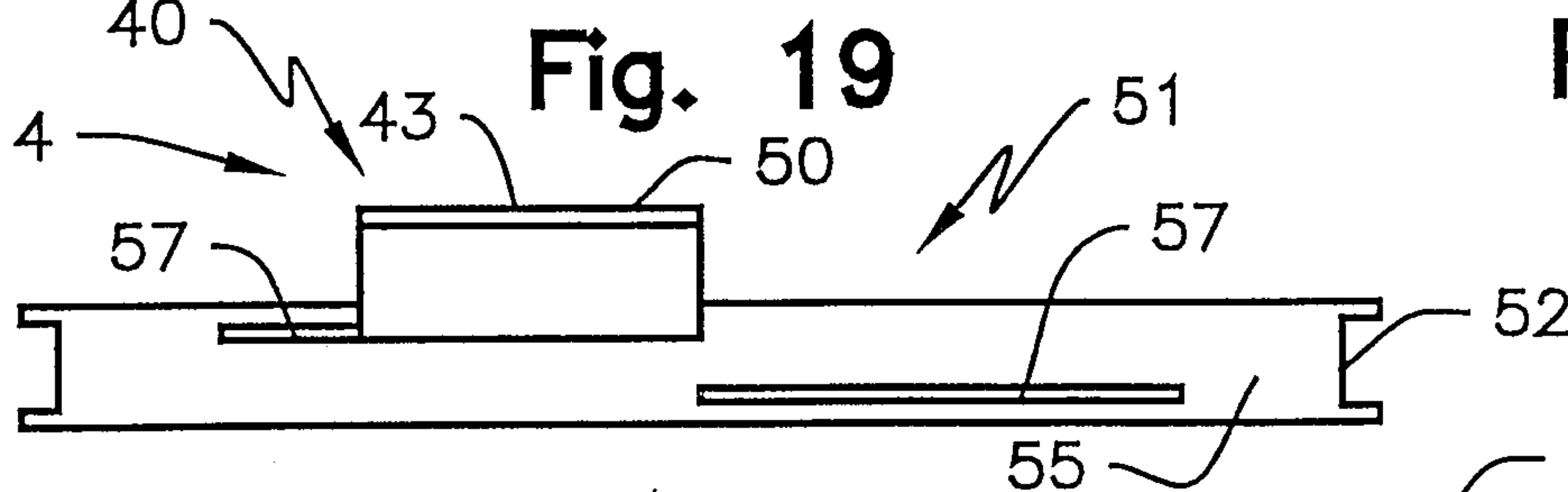
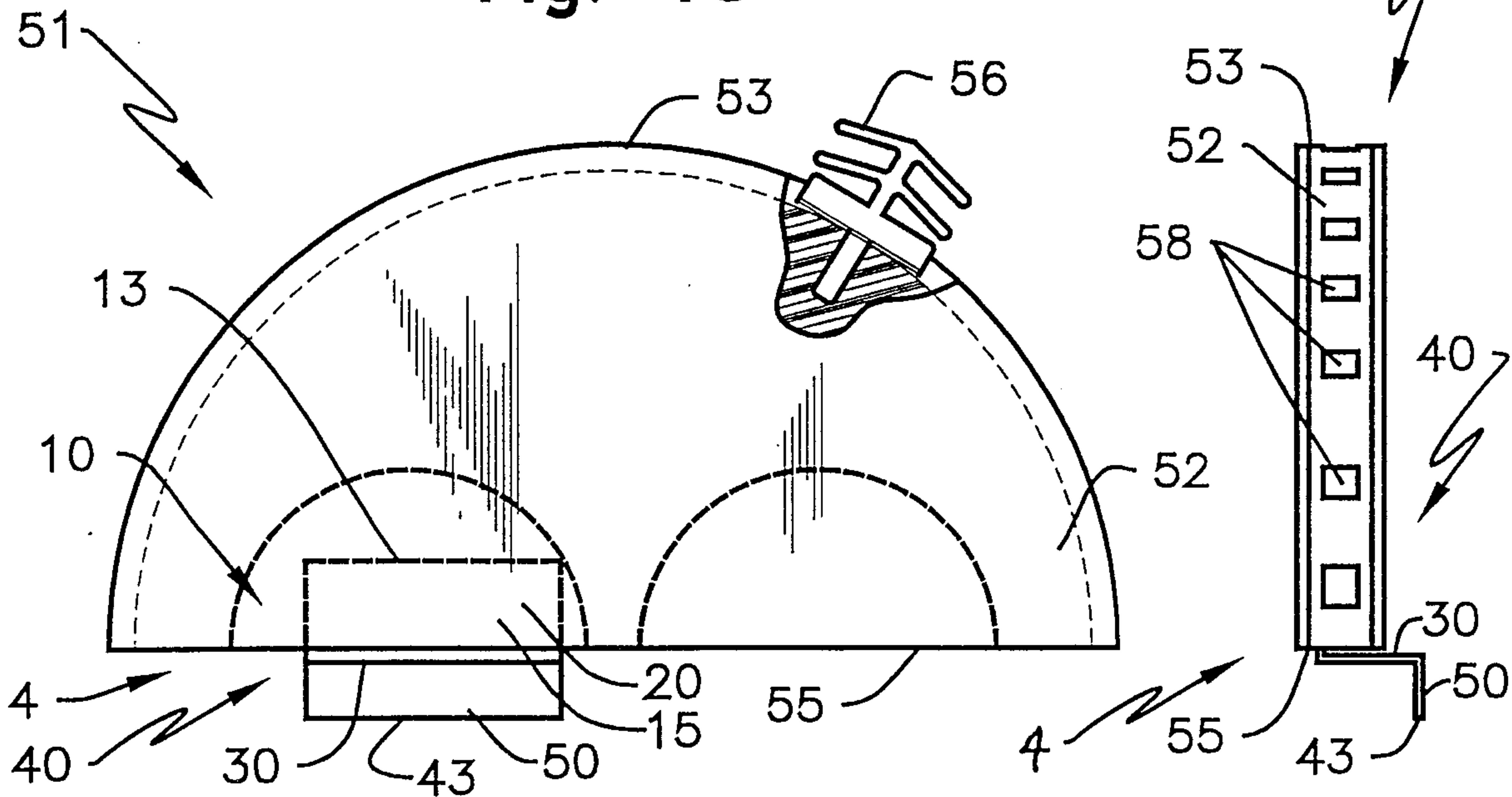
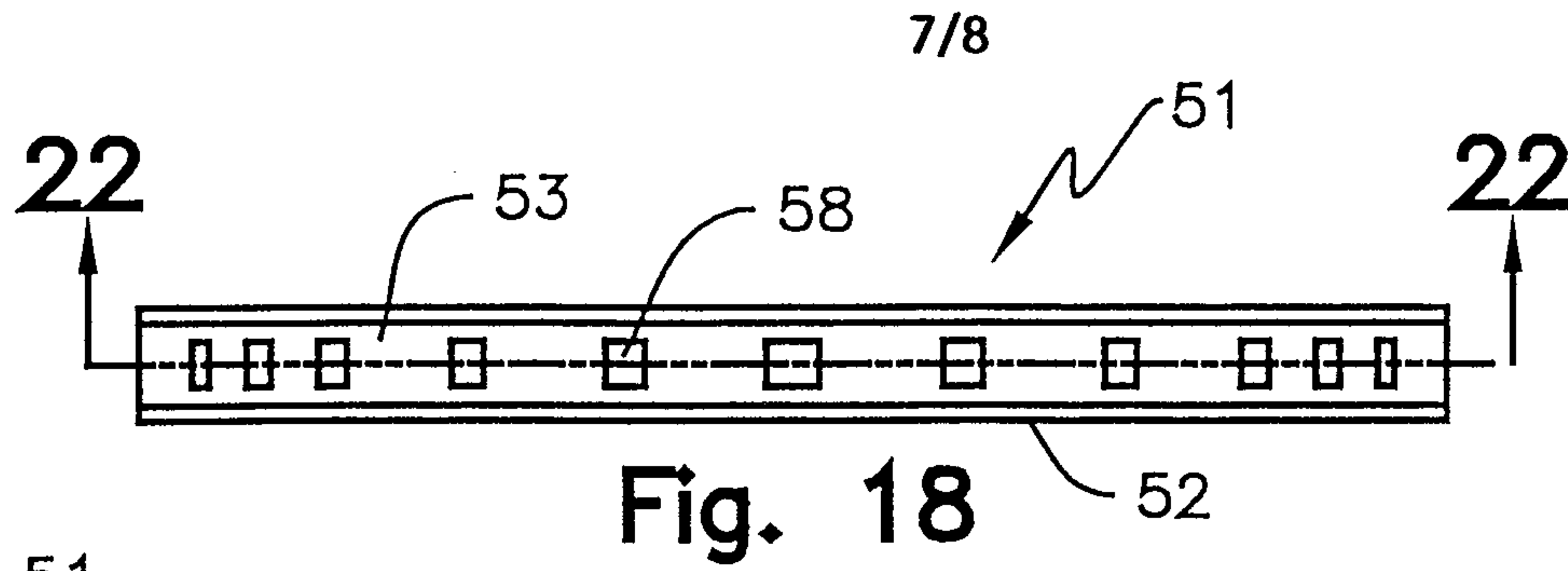

Fig. 17



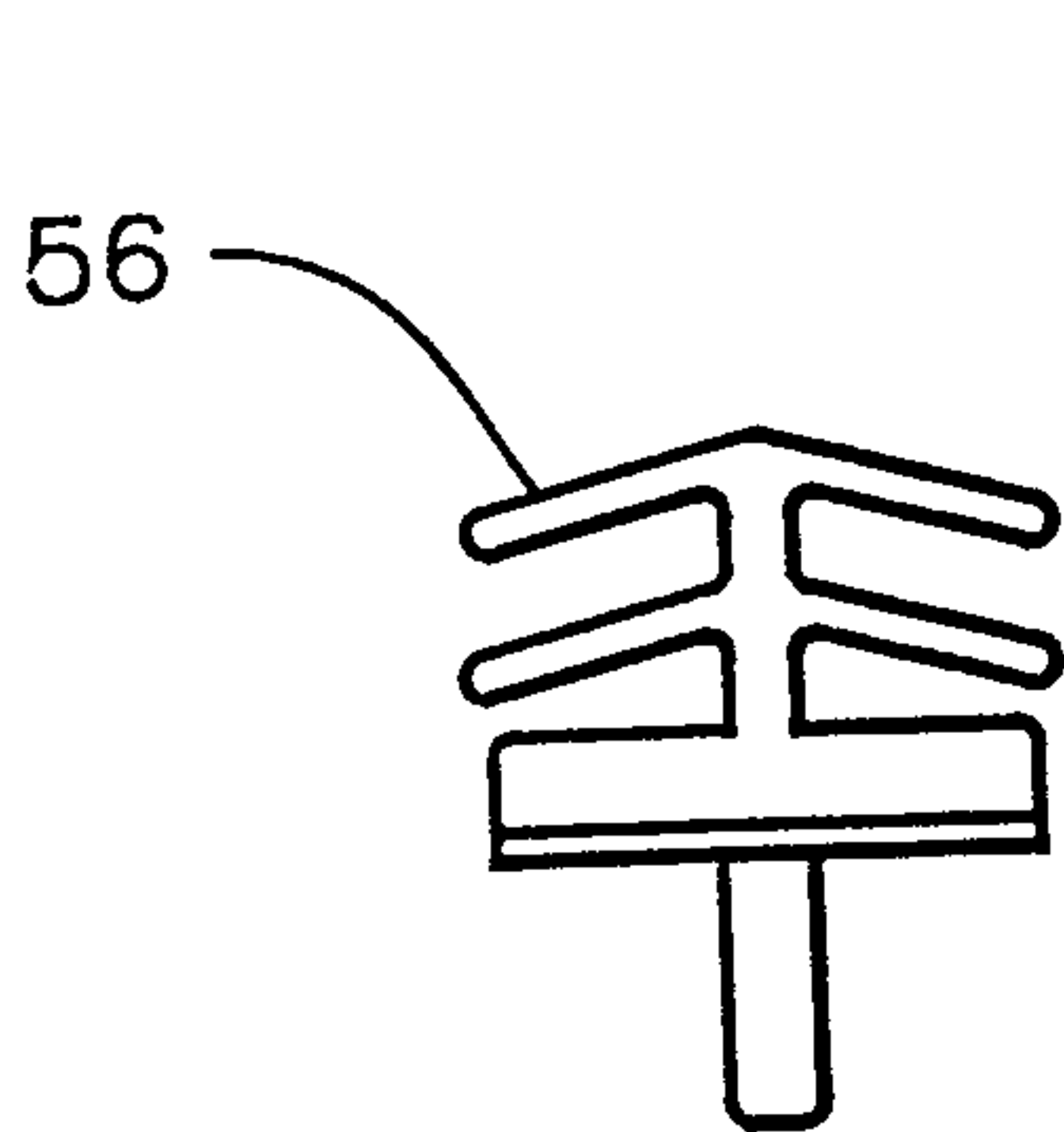

Fig. 23

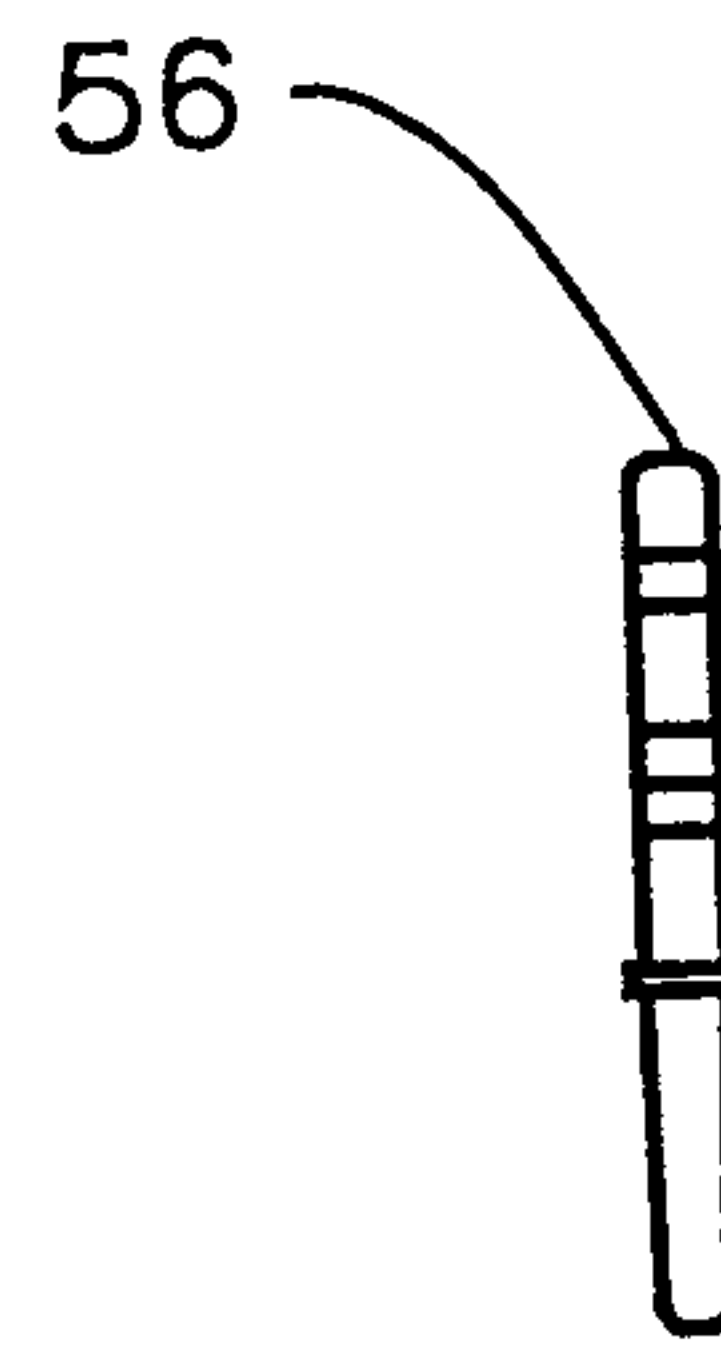

Fig. 24

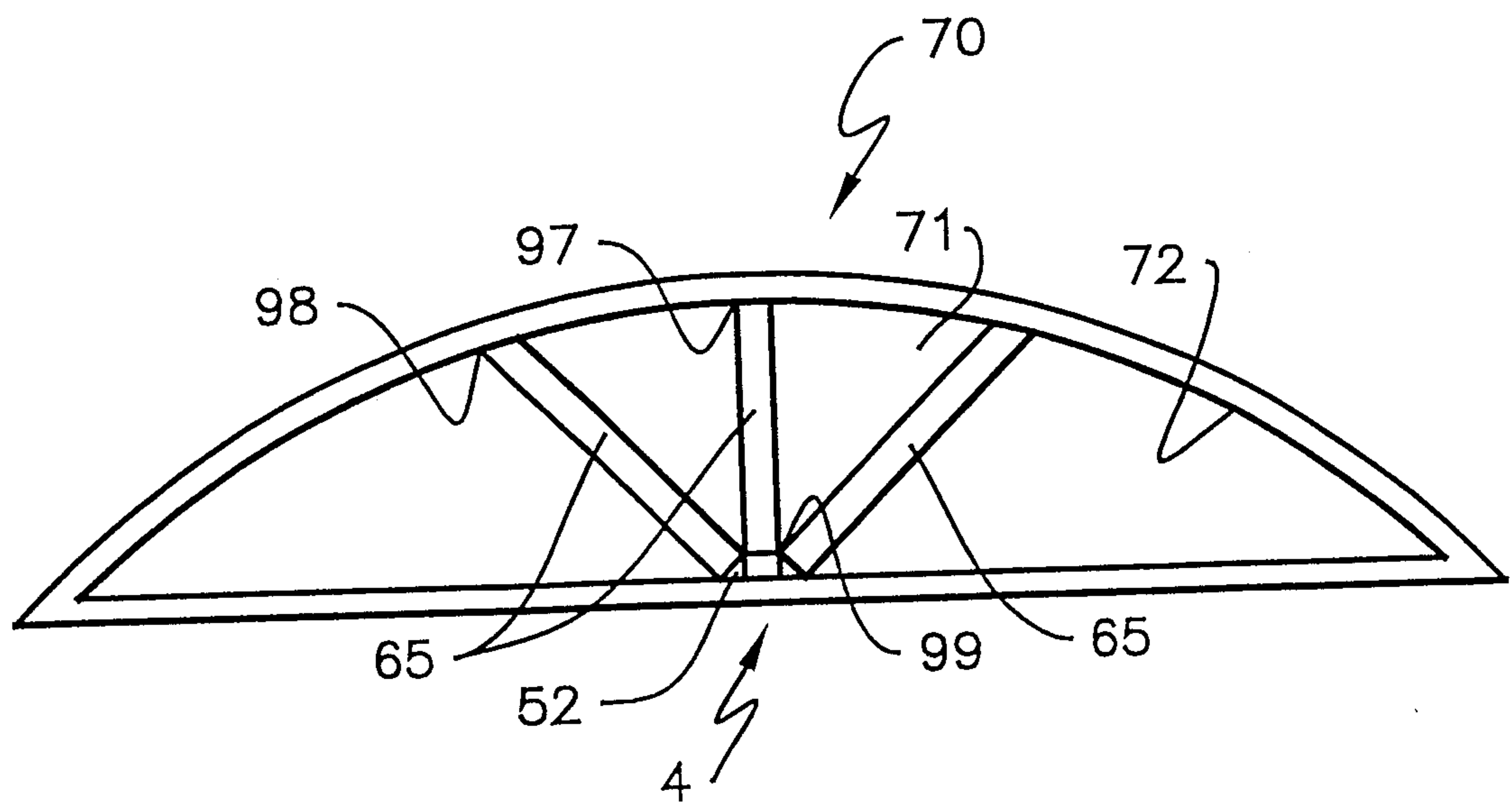

Fig. 25

