

March 4, 1952

L. C. PAGENHARDT
AIR ACTUATED CHANCE DEVICE

2,588,038

Filed March 13, 1950

Fig. 1.

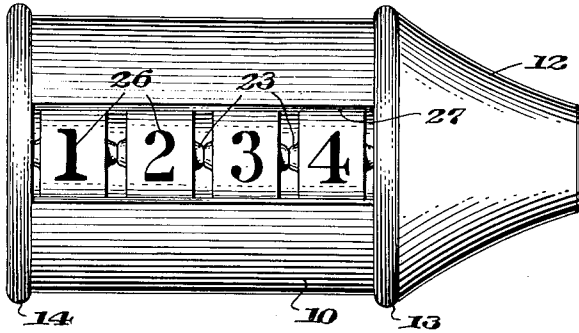

Fig. 3.

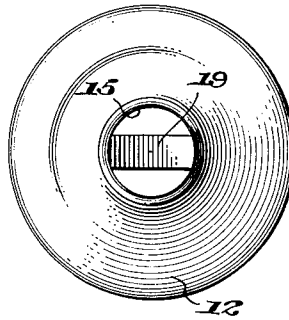

Fig. 2.

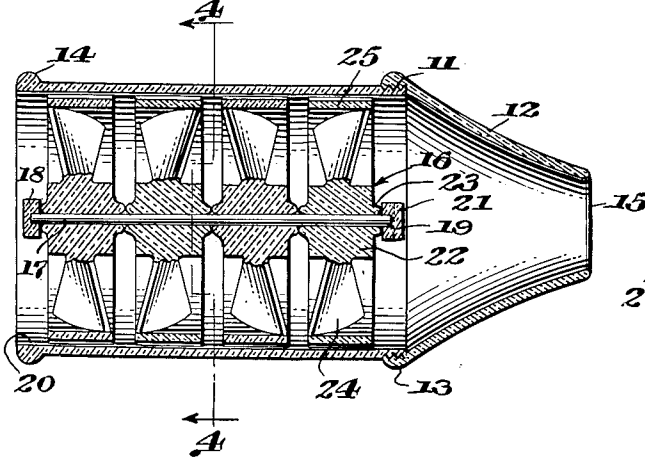

Fig. 4.

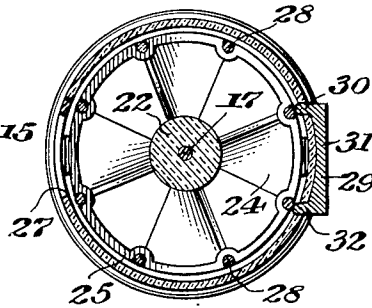
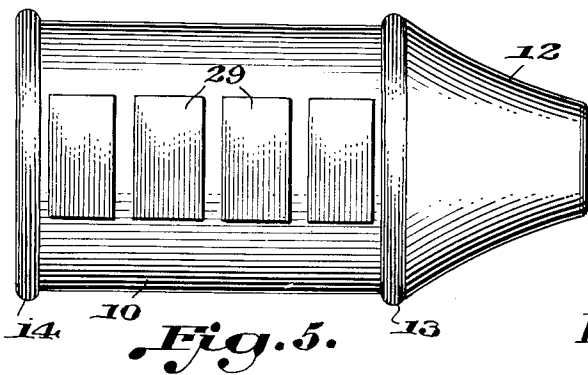
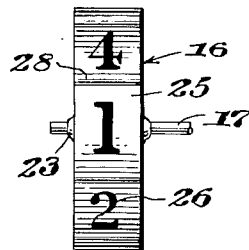

Fig. 6.



INVENTOR

Leonard C. Pagenhardt.

BY

Munn, Liddy & Haccum

ATTORNEYS.

UNITED STATES PATENT OFFICE

2,588,038

AIR ACTUATED CHANCE DEVICE

Leonard C. Pagenhardt, Roanoke, Va.

Application March 13, 1950, Serial No. 149,372

2 Claims. (Cl. 273-143)

1

This invention relates to amusement devices and more particularly to articles for playing games based upon possible combinations of numerals or figures.

An object of the invention is to provide a device comprising a plurality of air actuated wheels which rotate in opposite directions and which contain on the periphery thereof legends that will aline various combinations when the wheels come to rest.

Another object of the invention is to provide an amusement device, as above described, in which permanent magnets are utilized to terminate rotation of the wheels once the supply of motivating air is interrupted.

A further object is to present a small amusement device which is light in weight in order to make the article capable of being carried in a pocket of the owner's clothing.

A still further advantage of my invention is that it provides a game playing article that is economical and simple to manufacture both as to material and structure.

These and other objects and advantages of the invention will become apparent from the following description and the accompanying drawings in which:

Figure 1 is a front elevation view of the invention;

Figure 2 is a sectional view taken along the longitudinal axis of the device;

Figure 3 is a right side elevation of the article as shown in Fig. 1;

Figure 4 is a sectional view taken on the line 4-4 in Fig. 2;

Figure 5 is a rear elevational view of the invention;

Figure 6 is an elevational view of one of the wheels used in the device.

Similar reference characters in the several figures represent similar parts.

In keeping with the constant effort to produce entertainment for the public I have devised the present invention which I feel appeals to not one particular group, such as children, or adults, but, in fact, provides unlimited entertainment and amusement for people of all ages. The device is similar in result to various mechanical devices which utilize complicated and involved machinery to bring about various combinations of numbers or pictures, which combinations are incorporated into the rules of scoring for various games. By means of the structure described in this specification I have not only retained the interest afforded by the above-mentioned devices, but have also added to this interest a greater element of chance by removing the possibility of mechanical adjustment which might bring

2

about artificial alinement of the numerals or figures;

My invention is intended and designed to be merely a pocket article which can be easily tucked away in the clothing so that it is at all times available for entertainment. The entertainment value of this device cannot be over emphasized and it is this type of game apparatus that has for many years been enthusiastically received by the American public. It is an inherent nature of the public to enjoy an uncomplicated game which incorporates the element of chance. The present invention is a device which lends itself to such a game and may be the source of competitive contests or may be equally as amusing and entertaining to an individual who has time on his hands, such as one engaged in traveling, invalids, etc.

The scoring wheel elements of this device may be interchangeable with an equal number of elements containing a different form of numeral or figure and in this manner an infinite number of interesting games are possible with the use of the article. The subject of the individual games is limited only by the imagination of either the manufacturer or the user. In this regard it will be readily seen that by providing index wheels with proper legends, games such as baseball, football, racing, or even several card games may be played.

In addition to the educational and interest aspect afforded by the above described games the unique operation of the rotating index wheels affords unusual attraction to children who may or may not be of insufficient age to enjoy or comprehend complex games which may be played with the same instrument. The device further lends itself to modification in such manner as to provide a whistle or siren sound as the individual wheels rotate, this feature further adding to the amusement of the small child. In reality the device, as shown in the accompanying drawings does produce a slight whirring noise.

To describe the invention in detail reference is first made to Figure 1 of the drawing in which it will be seen that the device consists basically of a hollow cylindrical sleeve or body 10 preferably formed of opaque plastic of any color or combination of colors desired. The outer periphery at one end of the sleeve 10 is provided with screw threads 11 extending inwardly a short distance from the extreme end of the sleeve. The screw threads 11 accommodate mating threads on the inner surface of a conical mouthpiece 12. These inner threads are formed on the end of the mouthpiece having the larger diameter and lie beneath an annular bead 13 provided to give sufficient body for the screw thread

connection. To add symmetry to the appearance of the article a matching annular bead 14 is provided at the opposite end of sleeve 10. The smaller end of mouthpiece 12 is open as at 15 in order to form a passage for an incoming air flow originating in the lungs of the user.

The operating mechanism of the device comprises a plurality of wheel members 16 which for the purpose of illustration have been shown in these drawings as four in number. It will, of course, be understood that any number of wheels from two up may conveniently be used depending upon the nature of the game to be played. Wheels 16 are journaled upon a common axle or pivot shaft 17. This shaft is preferably of cylindrical metallic stock, being journaled at its opposite ends in cross members or supports 18 and 19 disposed respectively at the two extremities of sleeve 10. The support bars 18 and 19 may be of plastic material similar to that used in the construction of sleeve 10, bar 18 being formed integral at each end with the inner surface 20 of the sleeve. Thus bar 18 extends transversely across the air exit at that end of the device, the remaining area of the exit end being completely open and unobstructed for free air flow.

Bar 19 is a removable element which extends through slots (not shown) oppositely disposed in the mouthpiece edge of sleeve 10. The ends of the bar 19 are formed with at least one segmental screw thread (shown as dotted line 21 in Fig. 2). These threaded ends engage with the inner threads on mouthpiece 12 to firmly lock the support bar 19 in position. This prevents longitudinal movement of member 19 relative to the axis of shaft 17 and accordingly retains the several wheels in proper position. As will be seen in Fig. 2, at a central point on the inner face of each member 18 and 19 a small hole or recess is formed which acts as a bearing seat for the appropriate ends of pivot shaft 17.

In considering the particular construction of the individual wheels 16 it will be seen from Fig. 2 of the drawing that each wheel is molded from a plastic composition and has a central hub portion 22 containing an axial opening therethrough which slidably receives shaft 17. Each of hubs 22 has on the opposite faces thereof a protruding lip 23 which is so designed as to present a minimum contact surface between the adjacent wheels and between the end wheels and support bars 18 and 19 respectively. It will be seen that by rounding lips 23 the actual contact between adjacent rubbing surfaces will be held to approximately a circular line around each lip. This feature is extremely important in that it enables the wheel to travel with a greater rate of rotational velocity with a less amount of air or wind and thereby increasing the effective action of the individual wheels.

Each hub 22 has a plurality of radially extending blades 24 which for the purpose of illustration have been shown in the drawing to be four in number for each wheel. Each blade is inclined relative to the vertical plane of the wheel, as shown in Figs. 2 and 6, and each will thus form an obstruction to the passing current of air the force of which will act upon the inclined blades in such a manner as to cause rotation of the blades and hub portion 22.

In order to provide greater interest in the game and greater effectiveness in the operation of the rotating wheels in order to thoroughly mix the numerals or figures I prefer that adjacent wheels alternate as to inclination of their

respective blades 24. In other words, the first index wheel, or that adjacent the mouthpiece of the device, may have its blades inclined in such a manner as to cause counter-clockwise rotation and the second have its baffle blades oppositely inclined so as to cause clockwise rotation of that wheel. This alternation as to blade inclination and direction of rotation is continued throughout the series of wheels. Therefore, in operation the wheels will present a jumbled and intriguing pattern as they rotate in opposite directions.

On the outer edges of the radial blades 24 of each wheel there is integrally formed a plastic rim 25 which completely encircles the previously described blades and hub portion. The outer periphery of rim 25 forms the surface upon which may be inscribed numerals or other figures 26. These characters to be used in the various games may be formed or compressed at the time of the wheel molding operation or may be conveniently attached by means of applying a strip of paper or other material completely around the periphery of the wheel rim, this strip containing the selected series of legend representations.

In order that the combination of numerals or figures may be viewed when the various wheels come to rest I provide an elongated window 27 (Fig. 1) which may be formed of clear plastic enabling the characters to be observed through this opening in the opaque wall of sleeve 10.

Because of the lightness of the plastic material used in the construction of the index wheels 16 and also due to the effective anti-friction bearing arrangement between the adjacent surfaces the rotating wheels attain considerable velocity and even after the current of air from the user's mouth is stopped the wheels would continue their rotation for a considerable time unless sufficient means was provided for preventing such rotation immediately upon discontinuance of the force of the air current. Also an effective means is preferable whereby the numerals on the individual index wheels will come to rest in perfect alignment in order to obviate guesswork or dispute as to the exact numeral or figure on each wheel appearing in window 27. This important feature is taken care of by the provision of a magnetic attraction arrangement consisting first of a plurality of iron wire bars 28 which extend transversely across the peripheral surface of each wheel 16 to divide said surface equally into a predetermined number of sections each section containing an individual numeral or figure. Bars 28 are seated in a semi-cylindrical recess formed in the outer surface of rim 25 and may be press fitted or adhesively connected in some convenient form. The bars 28 are closely adjacent the inner surface 20 of the sleeve member, there being provided only a minute clearance in order to insure free rotation of the various elements.

Referring to Figure 5 of the drawing it will be seen that on the back portion of sleeve 10 I provide a number of individual magnets 29. Obviously the number of these magnets is dependent upon the number of index wheels incorporated in the specific modification of the invention. The magnets are of the permanent type and for effective and sudden operation it has been found that magnets known as "alnico" type are preferable. Each magnet 29 has formed at its opposite ends inwardly extending flanges 30 which form the north and south poles of the magnet. The casing or sleeve 10 is formed with elongated slots in alignment with flanges 30 so that each

5

flange may extend through the wall of the sleeve to lie in close contact with the arcuate plane of the revolving core or bar members 28. The particular shape or design of magnets 29 is immaterial and for the purpose of illustration I prefer to show such magnets as being rectangular in plane with a flat outer surface 31 and an arcuate inner surface 32 similar in degree to the curvature of sleeve 10.

As best seen in Fig. 4 of the drawing the flanges 30, which form the opposite poles of each magnet, are spaced similarly to the symmetrical spacing of the core or bar members 28 so that when an individual wheel comes to rest it will have the member 28 in magnetic contact with each of the two poles of magnet 29. In positioning the individual magnets 29 I have found it advisable to alternate the north and south poles of each so that the north seeking pole of one magnet will be adjacent the south seeking pole of the magnet or magnets lying on each side thereof. This arrangement permits an increased attraction between a magnet and its associated series of core or bar members 28.

In practice it has been found that the moment the air supply is cut off from the revolving elements the strongly energized magnets 29 immediately attract a pair of adjacent core members 28 so that rotation of an individual wheel is interrupted and the wheel is locked in place due to the attraction between the poles 30 of the magnet and the two members 28 which have come to rest opposite those poles.

In the operation of this device the mouthpiece 12 is placed to the lips of the player and a forceful gust of air is transmitted into the device through opening 15. This current of air passing through the sleeve member 10 is opposed by the oppositely inclined blades on the several index wheels, this causing each wheel to rotate in its predetermined direction so that the numerals or figures on the peripheral surfaces of the wheels are completely jumbled. The rotational velocity of the individual wheels will vary minutely depending upon such features as the perfection of its journaling structure and its proximity to the original source of air power. This minute variation prevents any possibility of the wheels turning at a symmetric or uniform rate of rotation so that the identical combination of the numerals or figures will be retained between the several wheels.

Immediately upon the interruption of the air or wind from the player's mouth the individual "alnico" magnets will attract an adjacent pair of transverse iron bars or cores 28 and the various rotating elements will immediately come to rest. At this time the combination of numerals or figures may be observed and recorded, if desired, for purposes of scoring the selected game. The strength of the magnets 29 will insure that the resulting combination is retained in its place adjacent the window 27 until an over-powering force of air is again injected through opening 15 in the mouthpiece. From this simple and automatic operation it will be seen that the game becomes entirely a matter of chance and all possibility of dishonesty in playing the game or operating the device is removed. This is an important feature in view of the universal knowledge that mechanical movement devices of this type have heretofore been of such construction as to enable pre-setting of the apparatus in such a manner as to insure either the possibility or

6

improbability of obtaining winning combinations of characters on rotating wheels.

From the foregoing description of the present invention it will be seen that I have provided a very simple and economically constructed apparatus which may be classified both as a toy for children and an amusement device for both children and adults alike. This device may be made comparatively small in size so that it is at all times available when amusement or entertainment is desired.

While a preferred form of the invention has been shown for the purpose of illustration it is to be understood that it is not intended to limit the invention as to material from which the device may be constructed nor specific games or uses to which the article may be put. Variations in details of form may be made without departure from the invention as defined in the appended claims.

I claim:

1. An amusement device comprising a hollow body member having a passageway extending therethrough with opposite open ends, a shaft, means mounting said shaft longitudinally within the passageway, a plurality of wheels having apertured hubs rotatably mounted on said shaft, said hubs having rounded lateral contact surfaces, inclined blades extending radially from said hubs for rotation of the wheels in response to an air current sent through said passageway, each wheel having a rim disposed at the outer ends of the radial blades, characters on the outer periphery of each rim, means in said body member permitting visibility of desired portions of said outer peripheries and the characters thereon, a plurality of magnetically susceptible metallic members spaced about the circumference of each wheel, and magnetic means in said body member for attracting said metallic members to stop rotation of said wheels when said air current is interrupted.

2. An amusement device comprising a hollow cylindrical body member having opposite open ends, a shaft, means mounting said shaft longitudinally within the body member, a plurality of wheels having apertured hubs rotatably mounted on said shaft, inclined blades extending radially from said hubs for rotation of the wheels in response to air current, the blades on adjacent wheels being pitched in the opposite direction, each wheel having a rim disposed at the outer ends of the radial blades, characters on the outer periphery of each rim, means in said body member permitting visibility of desired portions of said outer peripheries and the characters thereon, a plurality of magnetically susceptible metallic members spaced about the circumference of each wheel, and a permanent magnet carried by said body member opposite each wheel for attracting said metallic members to stop rotation of said wheels when said air current is interrupted.

LEONARD C. PAGENHARDT.

REFERENCES CITED

The following references are of record in the file of this patent:

UNITED STATES PATENTS

Number	Name	Date
547,100	White	Oct. 1, 1895
807,927	Henwood	Dec. 19, 1905
2,041,466	Gertz	May 19, 1936