



(86) Date de dépôt PCT/PCT Filing Date: 2012/12/21
 (87) Date publication PCT/PCT Publication Date: 2013/06/27
 (85) Entrée phase nationale/National Entry: 2014/06/20
 (86) N° demande PCT/PCT Application No.: EP 2012/076782
 (87) N° publication PCT/PCT Publication No.: 2013/093066
 (30) Priorités/Priorities: 2011/12/22 (US61/579,336);
 2012/08/28 (US61/693,842)

(51) Cl.Int./Int.Cl. *H01H 33/59* (2006.01),
H01H 9/54 (2006.01), *H02H 7/26* (2006.01),
H02J 3/36 (2006.01)
 (71) Demandeur/Applicant:
 SIEMENS AKTIENGESELLSCHAFT, DE
 (72) Inventeur/Inventor:
 MOHADDES, MOJTABA, CA
 (74) Agent: SMART & BIGGAR

(54) Titre : DISPOSITIF DISJONCTEUR DE CIRCUIT CC HYBRIDE
 (54) Title: HYBRID DC CIRCUIT BREAKING DEVICE

FIG 3

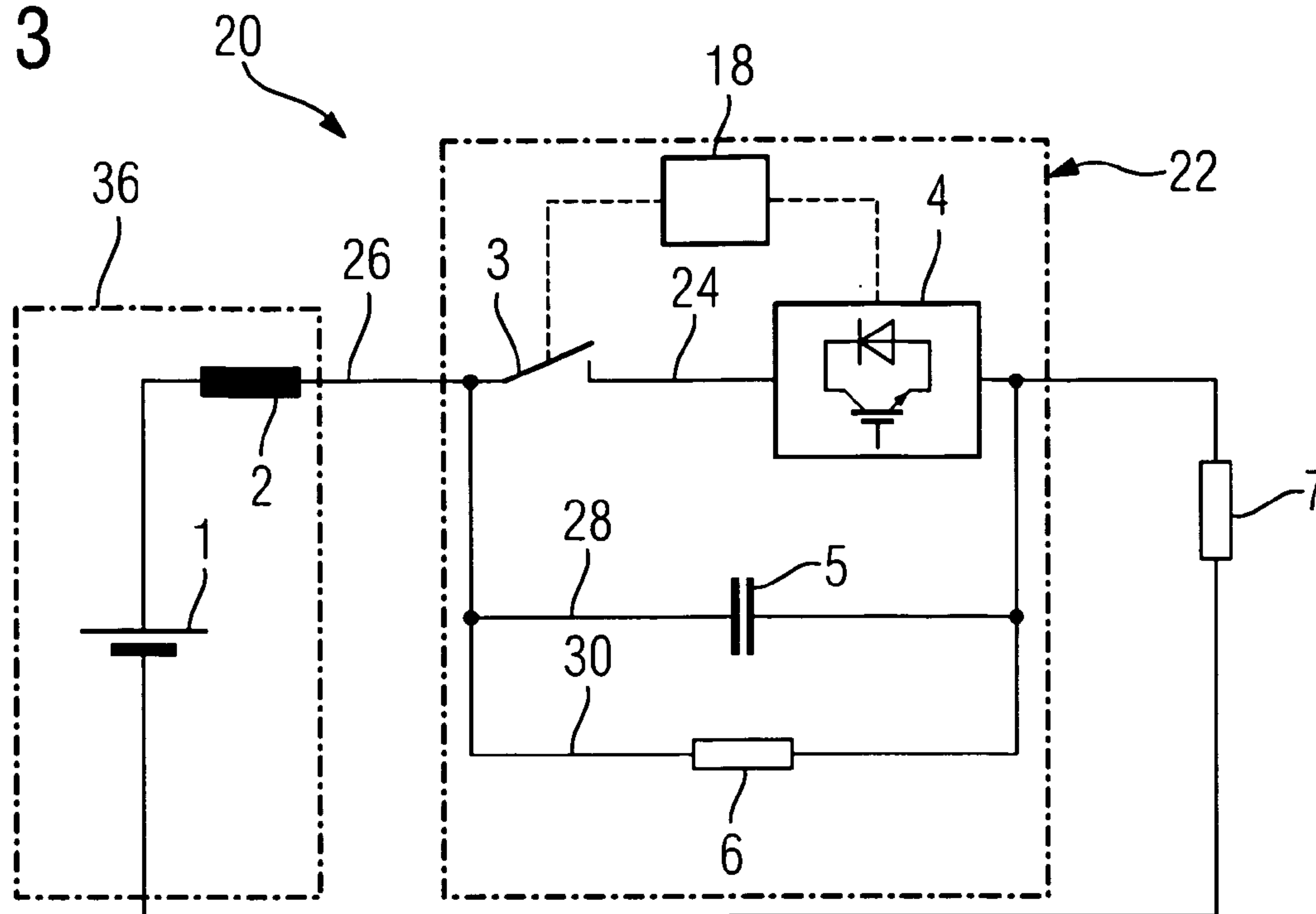

(57) **Abrégé/Abstract:**

According to the invention a dc(20) breaker is provided. The dc breaker is arranged in a main current path (26) connected between a first dc circuit (36) and a second dc circuit (7). The dc breaker comprises a primary current path (24) connected to the main current path. A mechanical interrupter switch (3) and an electronic breaker switch (4) are connected in series in the said primary current path. Furthermore, a secondary current path (28) is provided in parallel to the primary current path. In the secondary current path a capacitor (5) is arranged so as to be in parallel with the serially connected switches of the primary current path.



(12) INTERNATIONAL APPLICATION PUBLISHED UNDER THE PATENT COOPERATION TREATY (PCT)

(19) World Intellectual Property
Organization
International Bureau(10) International Publication Number
WO 2013/093066 A1(43) International Publication Date
27 June 2013 (27.06.2013)

(51) International Patent Classification:

H01H 33/59 (2006.01) H02J 3/36 (2006.01)
H01H 9/54 (2006.01) H02H 7/26 (2006.01)

(21) International Application Number:

PCT/EP2012/076782

(22) International Filing Date:

21 December 2012 (21.12.2012)

(25) Filing Language:

English

(26) Publication Language:

English

(30) Priority Data:

61/579,336 22 December 2011 (22.12.2011) US
61/693,842 28 August 2012 (28.08.2012) US

(71) Applicant: SIEMENS AKTIENGESELLSCHAFT
[DE/DE]; Wittelsbacherplatz 2, 80333 München (DE).(72) Inventor: MOHADDES, Mojtaba; 140 Farmingdale
Boulevard, Winnipeg, Manitoba R3P 2G5 (CA).(81) Designated States (unless otherwise indicated, for every
kind of national protection available): AE, AG, AL, AM,
AO, AT, AU, AZ, BA, BB, BG, BH, BN, BR, BW, BY,
BZ, CA, CH, CL, CN, CO, CR, CU, CZ, DE, DK, DM,
DO, DZ, EC, EE, EG, ES, FI, GB, GD, GE, GH, GM, GT,
HN, HR, HU, ID, IL, IN, IS, JP, KE, KG, KM, KN, KP,

KR, KZ, LA, LC, LK, LR, LS, LT, LU, LY, MA, MD,
ME, MG, MK, MN, MW, MX, MY, MZ, NA, NG, NI,
NO, NZ, OM, PA, PE, PG, PH, PL, PT, QA, RO, RS, RU,
RW, SC, SD, SE, SG, SK, SL, SM, ST, SV, SY, TH, TJ,
TM, TN, TR, TT, TZ, UA, UG, US, UZ, VC, VN, ZA,
ZM, ZW.

(84) Designated States (unless otherwise indicated, for every
kind of regional protection available): ARIPO (BW, GH,
GM, KE, LR, LS, MW, MZ, NA, RW, SD, SL, SZ, TZ,
UG, ZM, ZW), Eurasian (AM, AZ, BY, KG, KZ, RU, TJ,
TM), European (AL, AT, BE, BG, CH, CY, CZ, DE, DK,
EE, ES, FI, FR, GB, GR, HR, HU, IE, IS, IT, LT, LU, LV,
MC, MK, MT, NL, NO, PL, PT, RO, RS, SE, SI, SK, SM,
TR), OAPI (BF, BJ, CF, CG, CI, CM, GA, GN, GQ, GW,
ML, MR, NE, SN, TD, TG).

Declarations under Rule 4.17:

— as to the applicant's entitlement to claim the priority of the
earlier application (Rule 4.17(iii))

Published:

— with international search report (Art. 21(3))
— before the expiration of the time limit for amending the
claims and to be republished in the event of receipt of
amendments (Rule 48.2(h))

(54) Title: HYBRID DC CIRCUIT BREAKING DEVICE

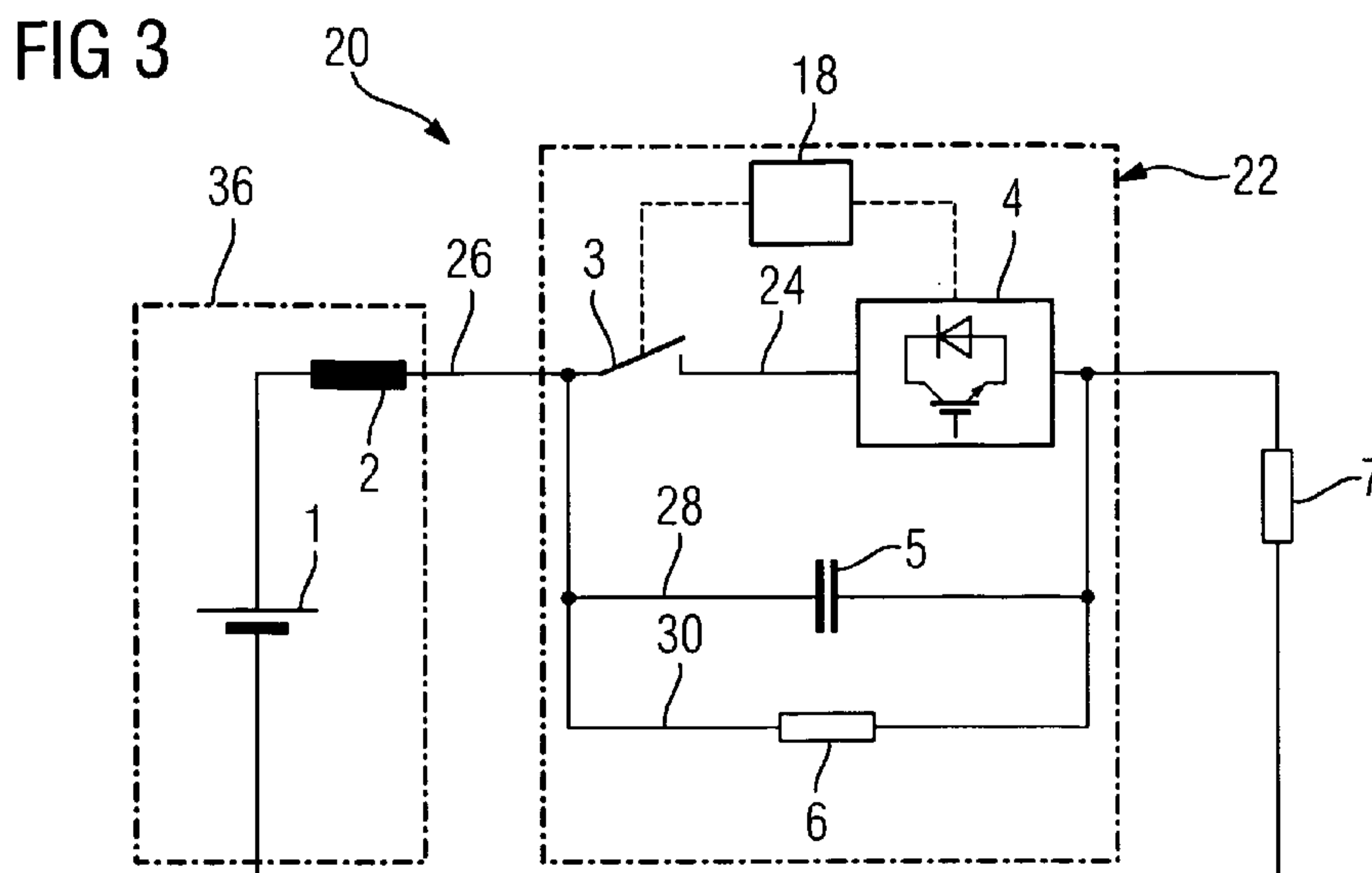

(57) Abstract: According to the invention a dc(20) breaker is provided. The dc breaker is arranged in a main current path (26) connected between a first dc circuit (36) and a second dc circuit (7). The dc breaker comprises a primary current path (24) connected to the main current path. A mechanical interrupter switch (3) and an electronic breaker switch (4) are connected in series in the said primary current path. Furthermore, a secondary current path (28) is provided in parallel to the primary current path. In the secondary current path a capacitor (5) is arranged so as to be in parallel with the serially connected switches of the primary current path.

HYBRID DC CIRCUIT BREAKING DEVICE

FIELD OF THE INVENTION

The present invention relates to a hybrid type dc circuit
5 breaking device comprising a breaker circuit having seri-
ally connected mechanical and electronic switches and a
capacitor in parallel with the serially connected swit-
ches; and more particularly the present invention relates
to possible use of the breaker circuit in combination
10 with one or more varistors to stop or allow the flow of
dc current in an electric circuit. Moreover, this inven-
tion comprises the fast discharge circuit to allow for
fast reclose of the dc breaker.

15 BACKGROUND

A prior art Hybrid dc Circuit breaker as shown in Figure
1 is described in the publication "Protective Hybrid HVdc
Breakers - A Key Innovation for Reliable HVdc Grids," by
Jurgen Hafner and Bjorn Jacobson in CIGRE Intemational
20 Symposium, Bologna, Italy, Sept. 13-15, 2011, which is
incorporated herein by reference. More particularly in
the publication a hybrid dc breaker is disclosed consist-
ing of a mechanical fast disconnecter, an electronic aux-
iliary dc breaker and an electronic main dc breaker as
25 shown in Figure 1. During the normal operation the fast
disconnecter, the auxiliary dc breaker and the residual
dc current breaker are closed and the main dc breaker is
open. The dc current flows through the residual dc cur-
rent breaker, fast disconnecter and the auxiliary dc
30 breaker and current through the main dc breaker remains
at almost zero. When the breaker is required to open the
auxiliary dc breaker is ordered to open and the main dc
breaker is ordered to close. This will commutate the cur-
rent to the main dc breaker in a very short time, nor-
35 mally a fraction of a millisecond. At the same time the
mechanical fast disconnecter is ordered to open. The me-

chanical fast disconnecter opens at zero current as the dc current is already commutated to the main dc breaker. Once the mechanical fast disconnecter is in open position the main dc breaker breaks the current. The hybrid dc
5 breaker is able to break fault currents in a short time and has low losses when it is closed. The hybrid dc breaker described above offers an acceptable breaking time for most applications and reasonably low losses, however it requires an electronic main dc breaker. The main dc
10 breaker must have a voltage rating higher than the rated voltage of the dc circuit. It may also be required that the main dc breaker be able to break the dc current in either direction, which will add to the complexity of its design and increase the number of its components.

15

SUMMARY OF THE INVENTION

The present invention is similar to the above mentioned hybrid dc breaker in using a mechanical switch (which can be a fast disconnecter) and an auxiliary electronic dc
20 breaker, but it replaces the main dc breaker with a capacitor.

According to one aspect of the invention there is provided circuit breaking device for breaking a current containing a dc component in a main current path connected
25 between a first dc circuit and a second dc circuit, the device comprising:

- a primary current path connected to the main current path;
- 30 - a mechanical interrupter switch connected in the primary current path and having contacts movable relative to one another between a closed position arranged to conduct current flowing therethrough and an open position arranged to break a current flowing therethrough;
- 35 - an electronic breaker switch connected in series with the mechanical interrupter switch in the primary current

path and being operable to open from a closed state arranged to conduct current flowing therethrough to an open state arranged to break a current flowing therethrough upon receipt of an electronic opening signal;

- 5 - a secondary current path connected in parallel with the primary current path; and
- a capacitor connected in the secondary current path so as to be in parallel with the serially connected switches.

10

Preferably a controller arranged to displace the mechanical switch into the open position immediately subsequent to opening of the electronic breaker switch. Alternatively the electronic breaker switch can be opened
15 shortly after opening the mechanical switch.

In preferred embodiments the device also includes a tertiary current path connected in parallel with the primary current path and the secondary current path, and a varistor
20 connected in the tertiary current path so as to be in parallel with the serially connected switches and in parallel with the capacitor.

When the primary current path and the secondary current
25 path define a breaker circuit in series with the main current path, the device may further comprise an auxiliary current path connected in parallel with the first dc circuit in which the auxiliary current path includes an auxiliary varistor connected in series therewith.

30

When a first varistor is connected in the tertiary current path so as to be in parallel with the serially connected switches and in parallel with the capacitor and a second varistor connected in the auxiliary current path,
35 preferably the knee voltage of the second varistor is less than the knee voltage of the first varistor. The de-

vice may further include a second auxiliary current path in parallel with the second dc circuit and a third varistor connected in the second auxiliary current path so as to be in parallel with the second dc circuit.

5

The device may further comprise an auxiliary interrupter switch connected in series between the breaker circuit and either one of the first and second dc circuits.

10 The device may further include a fourth current path connected in parallel to the primary and secondary current paths.

The fourth current path preferably comprises a series
15 connected switch and a damping circuit. The damping circuit may comprise a damping resistor and a damping inductor in which the resistor and the inductor are connected in parallel to each other and together in series with the switch.

20

Alternatively the damping circuit may comprise a damping resistor connected in series with a spark gap and a damping inductor connected in parallel to the serially connected damping resistor and spark gap.

25

The switch can be mechanical, electronic, spark gap, plasma injection, vacuum tube or any other device or combination of devices that is capable of closing the circuit upon receiving a command signal and opening the circuit
30 either by a command signal or when its current or voltage is reduced below a threshold level.

The electronic breaker switch may comprise a solid state semiconductor based circuit breaker or a vacuum tube circuit breaker capable of interrupting current either in
35 only one direction or in both directions. Various embodi-

ments of the invention will now be described in conjunction with the accompanying drawings in which:

BRIEF DESCRIPTION OF THE DRAWINGS

5 Figure 1 is a schematic representation of a prior art dc circuit breaking device including a hybrid of mechanical and electrical breakers.

10 Figure 2 is a schematic representation of a dc circuit breaking device including a hybrid of mechanical and electrical breakers.

15 Figure 3 is a schematic representation of the dc circuit breaking device of Figure 2 with an additional tertiary current path and varistor in connection with two dc circuits.

20 Figure 4 is a graphical representation of the dissipation of current and voltage in response to opening of the dc circuit breaking device in Figure 3.

25 Figure 5 is a schematic representation of the dc circuit breaking device of Figure 3 in connection with two dc circuits with an additional auxiliary current path and an auxiliary varistor.

30 Figure 6 is a graphical representation of the dissipation of current and voltage in response to opening of the dc circuit breaking device in Figure 5.

35 Figure 7 is a schematic representation of the dc circuit breaking device of Figure 3 in connection with two dc circuits with two additional auxiliary current paths and auxiliary varistors.

Figure 8 is a graphical representation of the dissipation of current and voltage in response to opening of the dc circuit breaking device in Figure 7.

- 5 Figure 9 is a schematic representation of the dc circuit breaking device of Figure 3 in connection with two dc circuits with additional auxiliary current paths and varistors and an additional auxiliary interrupter switch.
- 10 Figure 10 is a graphical representation of the dissipation of current and voltage in response to opening of the dc circuit breaking device in Figure 9.

Figure 11 is a schematic representation of the dc circuit
15 breaking device of Figure 9 in connection with two dc circuits with additional fourth current path comprising a switch and damping circuit consisting of a resistor and an inductor.

- 20 Figure 12 is a graphical representation of the dissipation of current and voltage in response to opening of the dc circuit breaking device in Figure 11 and the reclose process which consists of discharging the capacitor 5 by closing switch 37 and then closing the mechanical switch
25 3 and the electronic switch 4 when the voltage across capacitor 5 is sufficiently low.

In the drawings like characters of reference indicate corresponding parts in the different figures.

30

DETAILED DESCRIPTION

- Referring to the accompanying figures, there is illustrated a circuit breaking device generally indicated by reference numeral 20. The device 20 is particularly
35 suited for use in series with the main current path 26 between a first direct current (dc) circuit 36 and a sec-

ond (dc) circuit 7 in which the first and second dc circuits 36 and 7 generally include and any bus bars, overhead transmission lines, cables, reactors, breakers, converters or any other components which may be related. In the example graphical representations of Figures 4, 6, 8,10 and 12 generated by computer simulation the dc circuit 36 is assumed to consist of the ideal dc voltage source 1 and the inductor 2, however in general the dc circuit 36 can consist of any other components as mentioned.

Although various embodiments are described, the common features of the various embodiments will first be addressed.

The device 20 generally includes a breaker circuit 22 represented in Figure 2. The circuit 22 includes a primary current path 24 which is arranged to be connected to the main current path 26 connecting the first dc circuit 36 and the second dc circuit 7. The breaker circuit 22 also includes a secondary current path 28 which is connected in parallel with the primary current path such that the primary and secondary current paths are together parallel connected and collectively form the breaker circuit in series with the main current path between the first dc circuit 36 and the second dc circuit 7.

A mechanical interrupter switch 3 is connected in the primary current path 24 in series therewith. Contacts of the mechanical interrupter switch are arranged to be moveable relative to one another between a closed position arranged to conduct current therethrough flowing through the primary current path, and an open position in which the primary current path is opened such that the current flowing therethrough is broken.

An electronic breaker switch 4 is also connected in series with the mechanical interrupter switch 3 in the primary current path 24. The electronic breaker switch 4 is a solid state semi-conductor type breaker which is readily operable from a closed state to an open state upon receipt of an electronic opening signal from a suitable controller 18. In the closed state, the electronic breaker switch is arranged to conduct current flowing through the primary current path. In the open state the switch is arranged to break current flowing therethrough. A rated voltage of the electronic breaker switch is lower than the rated voltage of the dc circuits 7 and 36.

The breaker circuit 22 further includes a capacitor 5 connected in the secondary current path 28 so as to be in parallel with the serially connected mechanical interrupter switch 3 and electronic breaker switch 4.

The controller 18 of the electronic breaker switch is also arranged to order the interrupter switch 3 to be mechanically displaced from the closed position into the open position immediately subsequent to opening of the electronic breaker switch by sending the electronic opening signal to this switch.

In the first embodiment of Figure 3, the device further includes a tertiary current path 30 which is connected in parallel with the primary current path 24 and the secondary current path 28 and also forms part of the collective breaker circuit 22 connected in series with the main current path 26. In this instance, a first varistor 6 is connected in the tertiary current path so as to be parallel with the serially connected switches 3 and 4 and in parallel with the capacitor 5.

35

According to a second embodiment shown in Figure 5, the device 20 also includes an auxiliary current path 32. In this instance, where the primary, secondary and tertiary current paths collectively define the breaker circuit 22 in series with the dc circuit 7, the auxiliary current path 32 is connected in parallel with the dc circuit 36. A second varistor 8 can then be connected in series with the auxiliary current path 32 so as to be connected in parallel with the main current path serially connecting the breaker circuit 22 and the dc circuit 7.

According to a third embodiment shown in Figure 7, the device 20 includes all of the features of the previous embodiment together with an additional auxiliary current path 34 connected in parallel with the dc circuit 7. In this arrangement, the auxiliary current path 34 and parallel connected dc current 7 are collectively connected in series with the breaker circuit 22. A third varistor 9 is connected in series with the auxiliary current path 34 such that the third varistor is in parallel with the second dc circuit 7 and the collective parallel connection of the third varistor and the second dc circuit 7 is in series between the breaker circuit 22 and the return path of the second dc circuit 7 to the first dc circuit 36.

Turning now to a fourth embodiment as shown in Figure 9, in this instance, the device 20 includes all of the features of the previous embodiment along with an additional auxiliary interrupter switch 10 connected in series with the main current path between the first dc circuit 36 and the breaker circuit 22. Alternatively the auxiliary interrupter switch 10 may be connected in series with the main current path 26 on the opposite side of the breaker circuit 22 between the breaker circuit 22 and the second dc circuit 7. The auxiliary current path 32 connects in

parallel with the main current path between the dc circuit 36 and the auxiliary interrupter switch 10.

In the fifth embodiment as shown in Figure 11, the device
5 20 includes all of the features of the previous embodiments with an additional fourth current path 41 defining a supplementary current path connected in parallel to the primary current path 24 and the secondary current path 28 and the tertiary current path 30 so that they are collectively
10 tively in series with the main current path 26.

A damping resistor 39 and a damping inductor 40 are connected in parallel to each other and collectively define a damping circuit which is connected in series to the
15 fourth current path 41.

Additionally a switch 37 is connected in series with the fourth current path 41 and the damping circuit formed by the parallel combination of the damping resistor 39 and
20 the damping inductor 40. The switch 37 can be mechanical, electronic, spark gap, plasma injection, vacuum tube or any other device or combination of devices that is capable of closing the circuit upon receiving a
25 command signal and opening the circuit either by a command signal or when its current or voltage is reduced below a threshold level.

Alternatively the damping circuit may consist of a damping resistor 39 connected in series with a spark gap and
30 a damping inductor 40 connected in parallel to the series combination of the damping resistor and the spark gap.

The functioning of the various embodiments described above will now be described in further detail. As described
35 above, Figure 3 shows an electric circuit consisting of a first dc circuit 36, a mechanical interrupter switch 3,

an electronic breaker switch 4, a capacitor 5, a varistor 6 and the remaining parts of the dc circuit schematically shown as block 7. In this case the first dc circuit 36 consists of a source of dc current 1 and an inductor 2 that represents the inductance present in the circuit, however in general the first dc circuit 36 can consist of any busbars, overhead transmission lines, cables, reactors, breakers, converters or any other components.

10 The source 1 can be a battery, a dc generator or any kind of electronic ac to dc converter. The reactor 2 represents the total inductance present between the source and the breaker. This includes any physical inductor and the inductance of the busbars, conductors and any stray inductances.

The mechanical switch 3 can be a circuit breaker, a load switch or a fast disconnecter. This mechanical switch will open at near zero dc voltage and current. The electronic breaker 4 is an electronic switch made of IGBT's, GTO's, GeT's, electron tubes or any other electronic components that is capable of being turned on and off by an electronic signal. The voltage rating of the auxiliary breaker 4 is lower than the rated voltage of the dc circuit. If the hybrid dc circuit breaker is required to break the dc current in both directions, the auxiliary electronic breaker must be capable of blocking current in both directions. The remaining parts of the dc circuit including any busbars, overhead transmission lines, cables, reactors, breakers, converters or any other components are schematically shown as block 7.

The current breaking principle of the new hybrid dc breaker circuit 22 is explained here with reference to Figure 3. When the hybrid dc breaker is closed the mechanical switch 3 is closed and the electronic breaker 4 is con-

ducting. The voltage across the capacitor 5 is equal to the voltage drop across the mechanical switch 3 plus the electronic breaker 4. Normally this voltage is very small compared to the rated voltage of the dc circuit. When the hybrid dc breaker is required to open a "turn off" order is sent to the electronic breaker 4. Within a short time before or after the electronic breaker 4 the mechanical switch 3 is also ordered to open. As a result of the "turn off" order to the electronic breaker the resistance of this device is increased, which will cause the dc current to be commutated to the capacitor 5. The capacitor voltage will start to rise at a rate related to its capacitance and the dc current intensity. The current flow through the mechanical switch 3 is reduced to nearly zero, which permits this device to open without any significant arcing. The voltage across the capacitor 5 will continue to rise until the current flow is stopped. The varistor 6 protects capacitor 5 from an overvoltage. Figure 4 shows the current and voltage waveforms for an example case where a short circuit occurs between the dc conductors at a point between the hybrid dc breaker 22 and the rest of the dc circuit 7.

When the short circuit occurs the dc current through mechanical switch 3 rises at a rate determined by the source 1 and the inductance 2. The first graph 1_3 in Figure 4 shows the current through the mechanical switch 3. As explained above shortly after the hybrid breaker is ordered to open the electronic breaker 4 is turned off causing the current to be commutated to the capacitor 5. This will cause the capacitor voltage V_5 to grow up to the knee voltage of the varistor 6. At this point varistor starts conducting and V_5 remains almost constant. The varistor knee voltage is higher than the voltage of the dc source 1 by design, therefore the polarity of the

voltage across the inductor 2 is such that the dc current is diminished. In Figure 4 - 3 is the current through the mechanical switch 3, 1_5 is the current through the capacitor 5, 1_6 is the current through the varistor 6 and 5 V_5 is the voltage across the capacitor 5.

As shown in the example above, in the hybrid dc breaker shown in Figure 3 some current may flow through the varistor 6 toward the dc circuit 7 for some time after the mechanical switch 3 was opened. The magnitude and duration of this current depends on the parameters such as the capacitance of the capacitor 5, the inductance of the reactor 2 and the knee voltage of the varistor 6. The flow of the current through the varistor after opening the breaker may not be acceptable in some applications. Figure 5 shows a variation of the hybrid dc circuit breaker where a varistor 8 is added to the circuit. The knee voltage for varistor 8 is selected below the knee voltage for the varistor 6. Figure 6 shows the simulation results for a short circuit event similar to the case shown in Figure 4. In Figure 6 all current and voltage designations are similar to Figure 4, the new trace L8 represents the current through the varistor 8. Figure 6 shows that the current through the varistor 6 is reduced to almost zero in this arrangement.

The hybrid dc breaker can be designed to break the current in both directions as explained earlier. In this case for a short circuit fault that occurs at a point on the circuit between the hybrid dc breaker and the first dc circuit 36, or within the first dc circuit 36, the behaviour of the hybrid dc breaker is similar to the previous cases discussed above. The rate of rise for the fault current will depend on the inductance of the complete fault current path in this case. Similar to the previous example the flow of current through the varistor 6 may

not be acceptable in some applications. A variation of the hybrid dc breaker shown in Figure 7 will reduce the current flow through varistor 6 to almost zero following a fault on either side of the breaker.

5

Depending on the characteristics of the first dc circuit 36 and the second dc circuit 7 and the location of the fault, when the hybrid dc breaker is ordered to open the current through the capacitor 5 may oscillate a number of times before settling at zero. Figure 8 shows an example of such possible situation. The flow of oscillatory current through the hybrid dc breaker's capacitor may not be acceptable in some applications. An embodiment of the dc hybrid breaker with an additional auxiliary interrupter switch 10 as shown in Figure 9 is capable of avoiding such oscillatory currents. When the hybrid dc breaker is required to open the auxiliary interrupter switch 10 is ordered to open as well as the mechanical switch 3 and the electronic breaker 4. The residual breaker completely stops the dc current as soon as its current reach zero. Figure 10 shows the same example simulation case shown in Figure 8, but with the embodiment of the hybrid dc breaker shown in Figure 9.

25 Some applications may require a fast reclose of the dc circuit breaker to resume the flow of the dc current. The fifth embodiment shown in Figure 11 allows a fast discharge of the capacitor 5 and reclosing of the mechanical interrupter switch 3 and electronic breaker switch 4.

30 Figure 12 shows a computer simulation example of the open and reclose procedure for the hybrid dc circuit breaker. The process of opening the dc breaker is similar to the process described in connection to the forth embodiment and the simulation example shown in Figure 10. At the end of this process the capacitor 5 is charged to the voltage V₅ as shown in Figure 12. When a fast reclose is re-

35

quired the switch 37 is ordered to close. This will provide a path for capacitor 5 to discharge through the damping resistor 39 and the damping inductor 40. The resistance and inductance of these elements are selected
5 such that the capacitor 5 is discharged within the required time. Once the capacitor voltage and current are below acceptable threshold the mechanical interrupter switch 3 and electronic breaker switch 4 are ordered to close and the current flow through the breaker is re-
10 sumed.

Since various modifications can be made in my invention as herein 25 above described, and many apparently widely different embodiments of same made within the spirit and
15 scope of the claims without department from such spirit and scope, it is intended that all matter contained in the accompanying specification shall be interpreted as illustrative only and not in a limiting sense.

Claims

1. A circuit breaking device for breaking a current containing a dc component in a main current path connected between a first dc circuit and a second dc circuit, the device comprising:
- a primary current path connected to the main current path;
 - a mechanical interrupter switch connected in the primary current path and having contacts movable relative to one another between a closed position arranged to conduct current flowing therethrough and an open position arranged to break a current flowing therethrough;
 - an electronic breaker switch connected in series with the mechanical interrupter switch in the primary current path and being operable to open from a closed state arranged to conduct current flowing therethrough to an open state arranged to break a current flowing therethrough upon receipt of an electronic opening signal;
 - a secondary current path connected in parallel with the primary current path; and
 - a capacitor connected in the secondary current path so as to be in parallel with the serially connected switches.
2. The device according to Claim 1 wherein a rated voltage of the electronic breaker switch is lower than a rated voltage of the first and second dc circuits.
3. The device according to either one of Claims 1 or 2 further comprising a controller arranged to order the electronic breaker switch to open or close and to displace the mechanical switch into the open position immediately subsequent to opening of the electronic breaker switch.
4. The device according to any one of Claims 1 through 3 further comprising a tertiary current path connected in parallel, with the primary current path and the secondary current path, and a varistor connected in the tertiary current path

so as to be in parallel with the serially connected switches and in parallel with the capacitor.

5. The device according to any one of Claims 1 through 4 wherein the primary current path and the secondary current path define a breaker circuit in series with the main current path, and wherein the device further comprises an auxiliary current path connected in parallel with the first dc circuit, the auxiliary current path including a varistor connected in series therewith.

6. The device according to any one of Claims 1 through 5 wherein the primary current path and the secondary current path define a breaker circuit in series with the main current path, and wherein the device further comprises:

- a tertiary current path connected in parallel with the primary current path and the secondary current path;
- a first varistor connected in series with the tertiary current path so as to be in parallel with the serially connected switches and in parallel with the capacitor;
- an auxiliary current path connected in parallel with the first dc circuit; and
- a second varistor connected in series with the auxiliary current path;

- a knee voltage of the second varistor being less than a knee voltage of the first varistor.

7. The device according to any one of Claims 1 through 6 wherein the primary current path and the secondary current path define a breaker circuit in series with the main current path, and wherein the device further comprises:

- a tertiary current path connected in parallel with the primary current path and the secondary current path;
- a first varistor connected in the tertiary current path so as to be in parallel with the serially connected switches and in parallel with the capacitor;
- a first auxiliary current path connected in parallel with the first dc circuit;

- a second varistor connected in the first auxiliary current path;
- a second auxiliary current path connected in parallel with the second dc circuit; and
- 5 - a third varistor connected in the second auxiliary current path.

8. The device according to any one of Claims 1 through 7 wherein the primary current path and the secondary current path
10 define a breaker circuit in series with the main current path, and wherein the device further comprises:

- an auxiliary interrupter switch connected in series between the breaker circuit and one of the first and second dc circuits.

15

9. The device according to any one of Claims 1 through 8 wherein the electronic breaker switch comprises a solid state semiconductor based circuit breaker capable of interrupting current in only one direction.

20

10. The device according to any one of Claims 1 through 8 wherein the electronic breaker switch comprises a solid state semiconductor based circuit breaker capable of interrupting current in both directions.

25

11. The device according to any one of Claims 1 through 8 wherein the electronic breaker switch comprises a vacuum tube circuit breaker capable of interrupting current in only one direction.

30

12. The device according to any one of Claims 1 through 8 wherein the electronic breaker switch comprises a vacuum tube circuit breaker capable of interrupting current in both directions.

35

13. The device according to any one of Claims 1 through 12 further comprising:

- a supplementary current path connected in parallel with the primary current path and the secondary current path;
 - a damping circuit connected in the supplementary current path; and
- 5 - a supplementary switch connected in series with the damping circuit in the supplementary current path in which the switch is operable between a closed state arranged to conduct current flowing therethrough and an open state arranged to break a current flowing therethrough.
- 10
14. The device according to Claim 13 wherein the damping circuit comprises a damping resistor and a damping inductor connected in parallel with one another.
- 15 15. The device according to Claim 13 wherein the damping circuit comprises a damping resistor connected in series with a spark gap and a damping inductor connected in parallel to the serially connected damping resistor and spark gap.

FIG 1
(PRIOR ART)

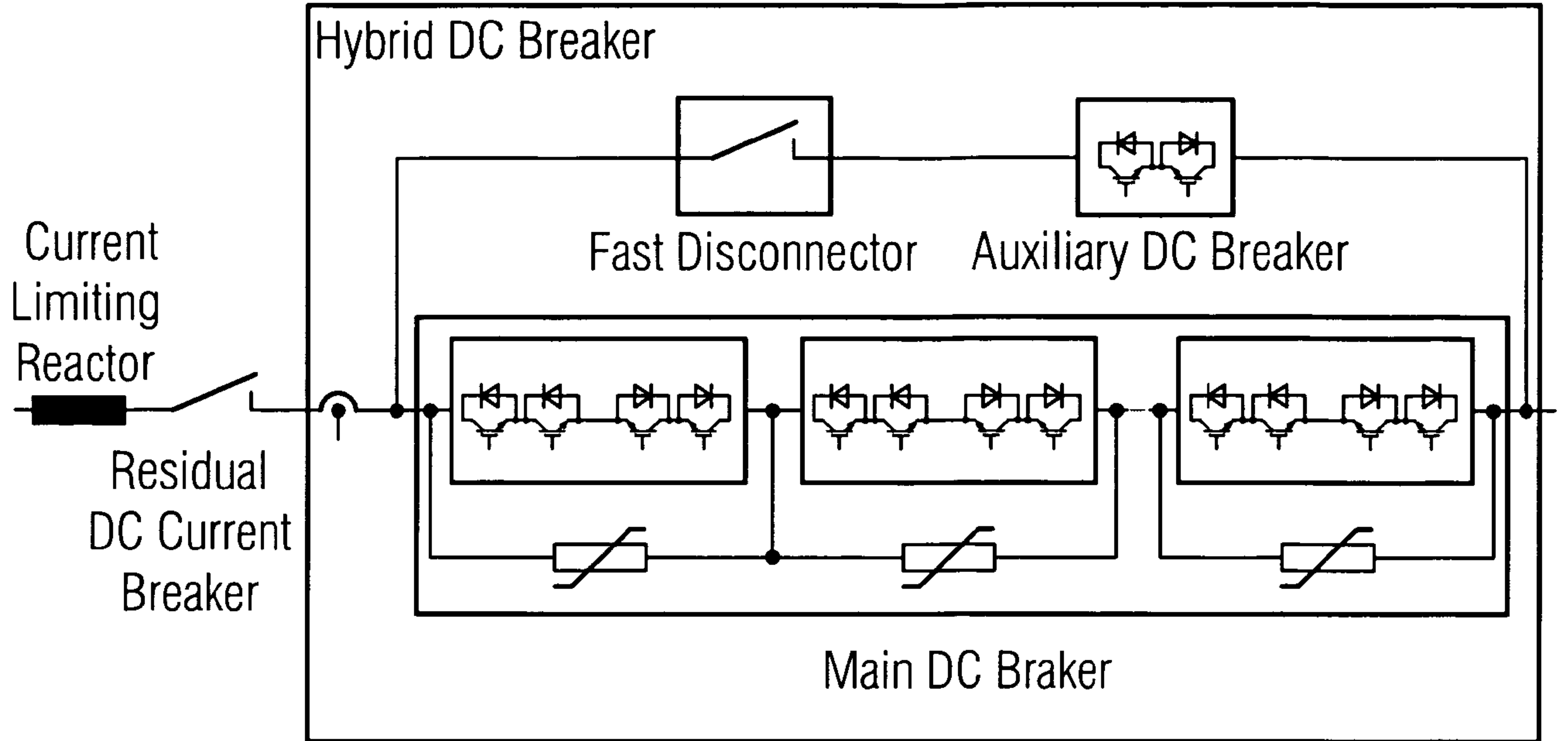

FIG 2

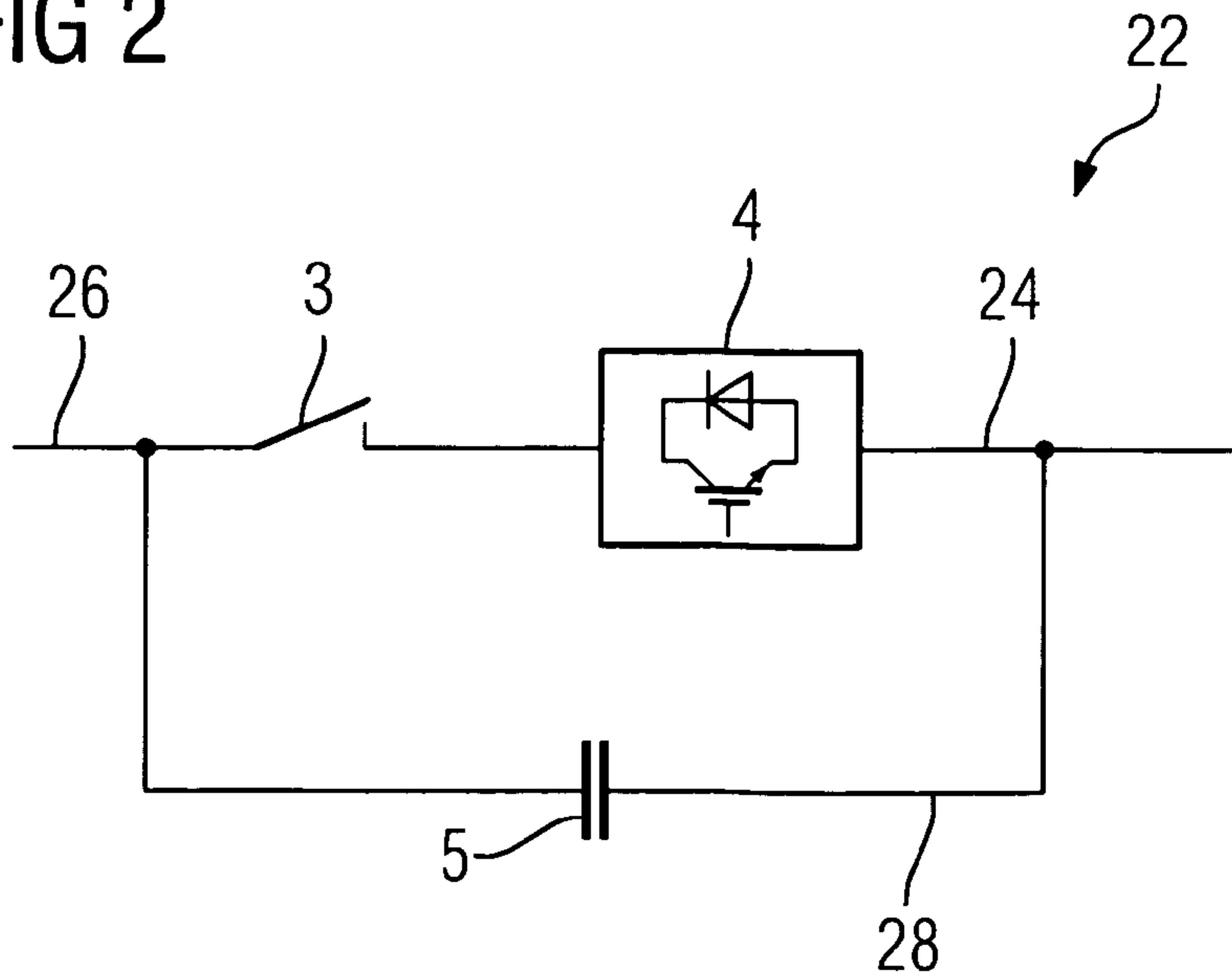

FIG 3

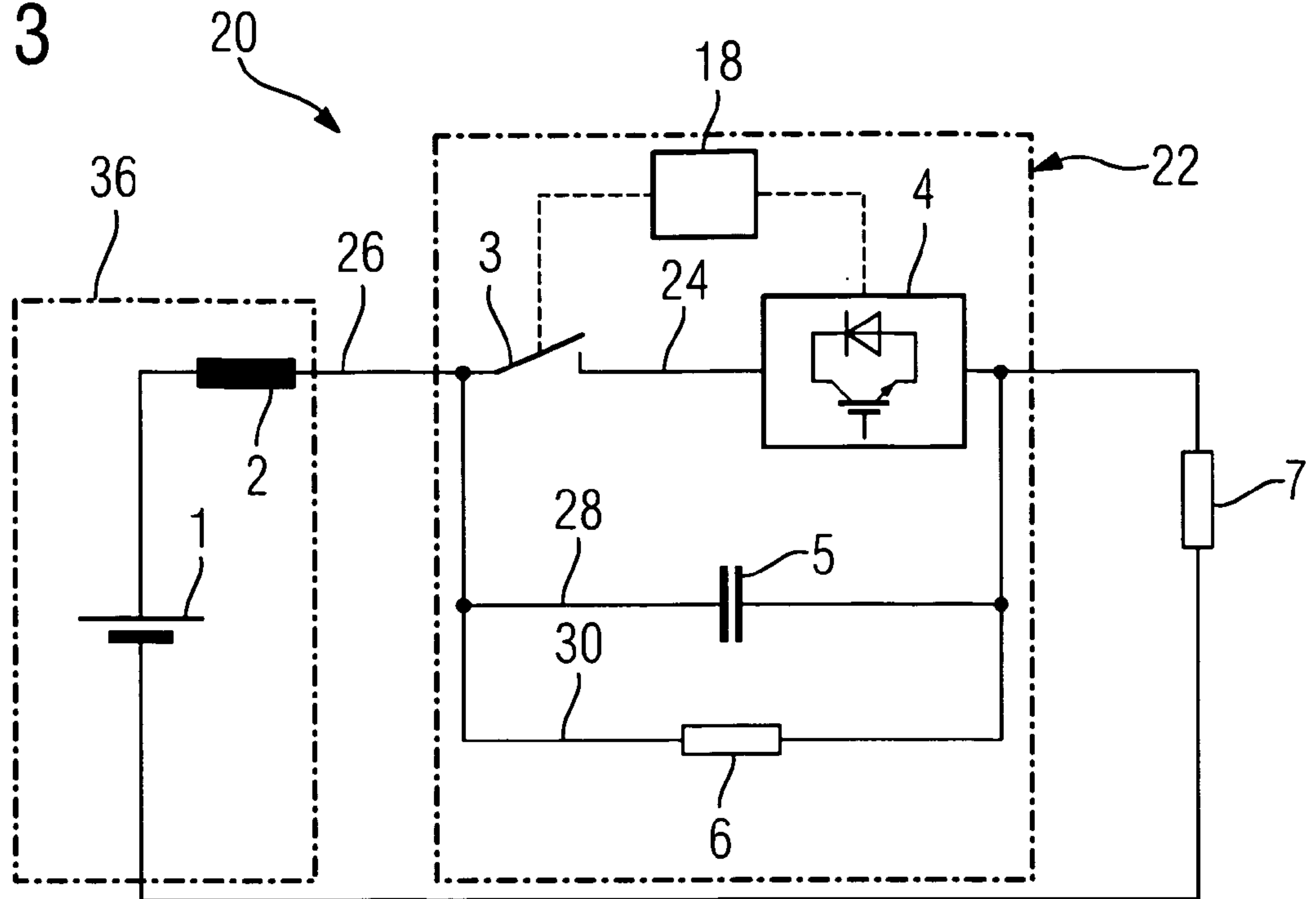

FIG 4

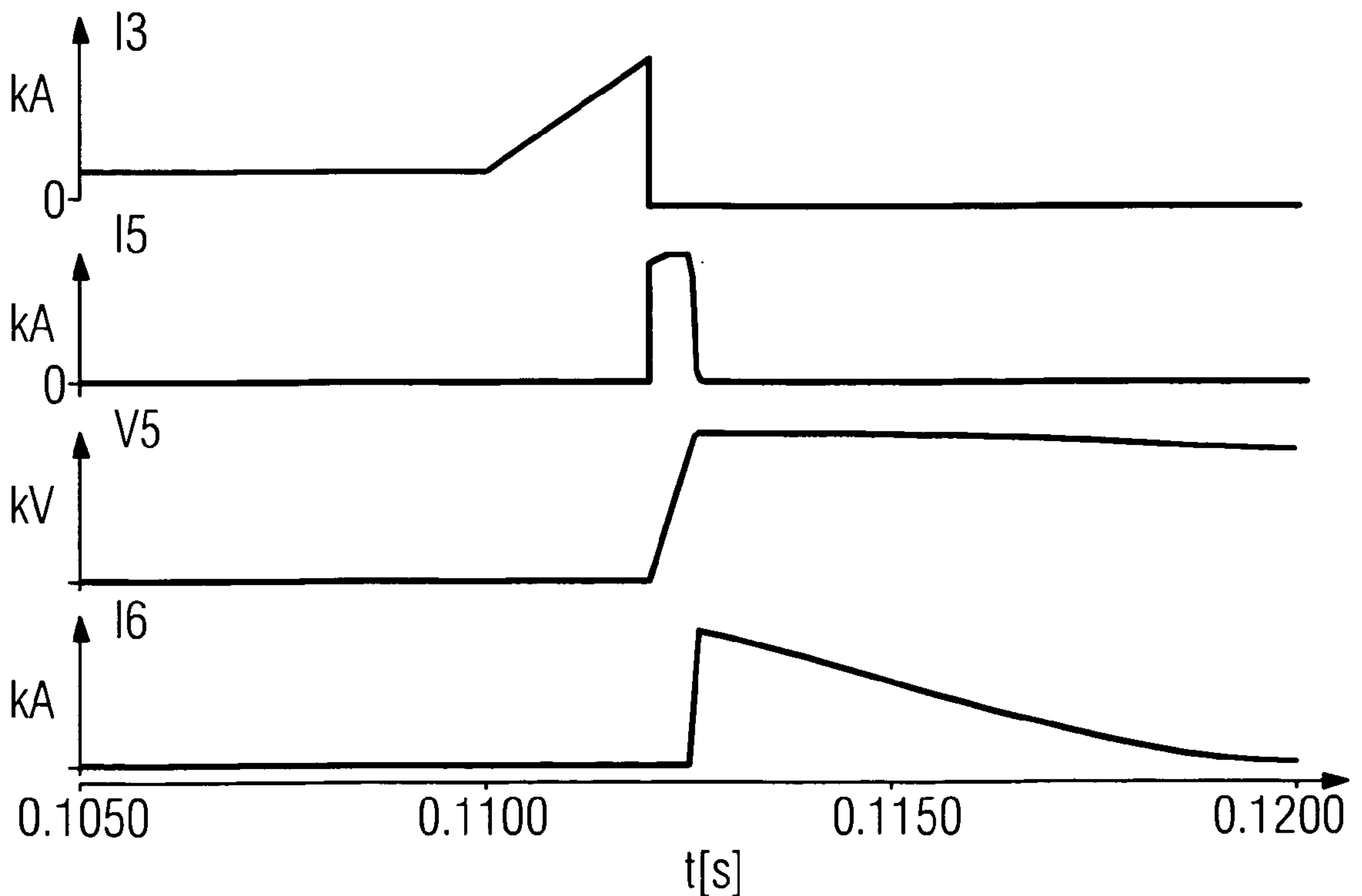

FIG 5

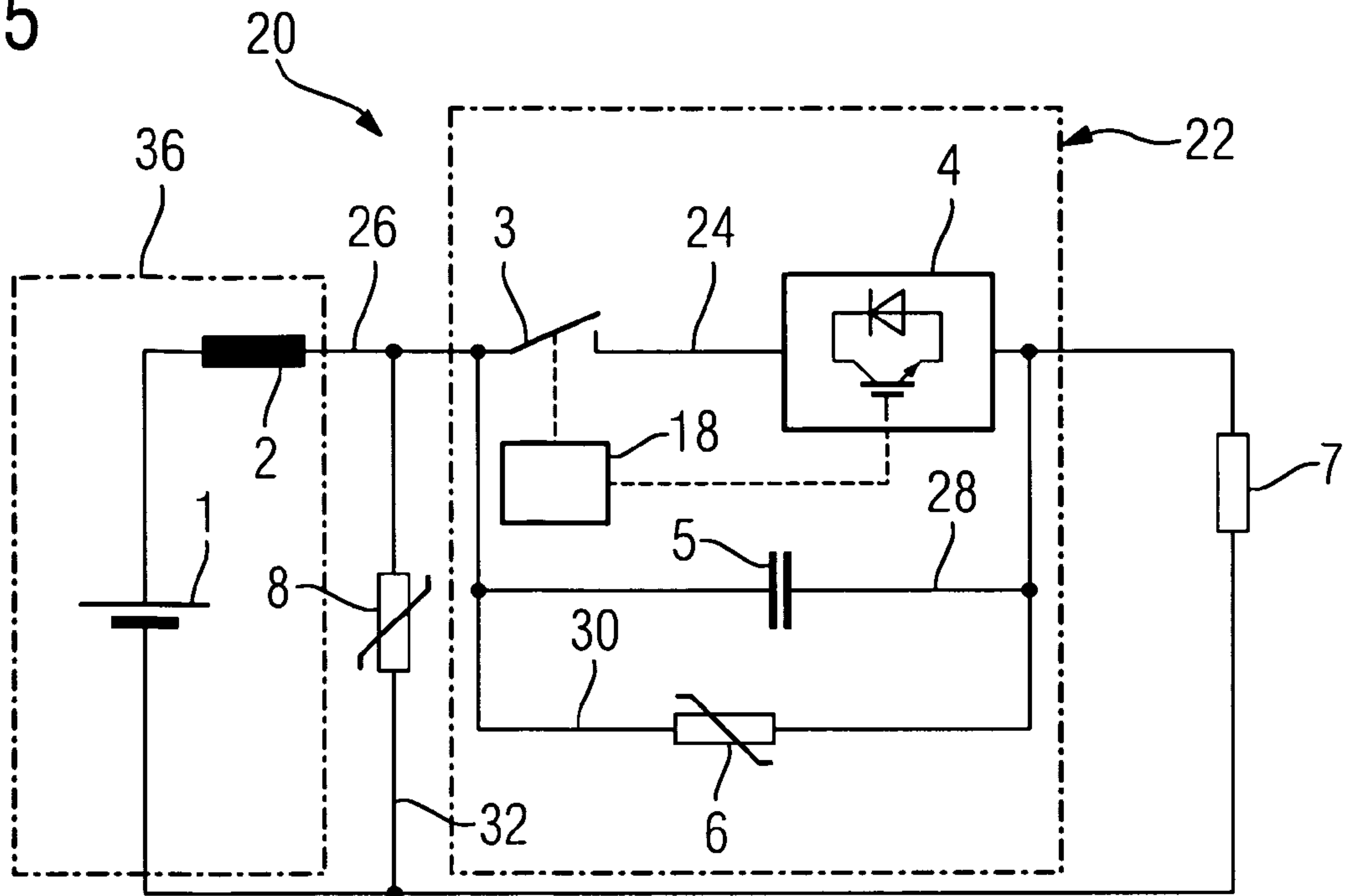

FIG 6

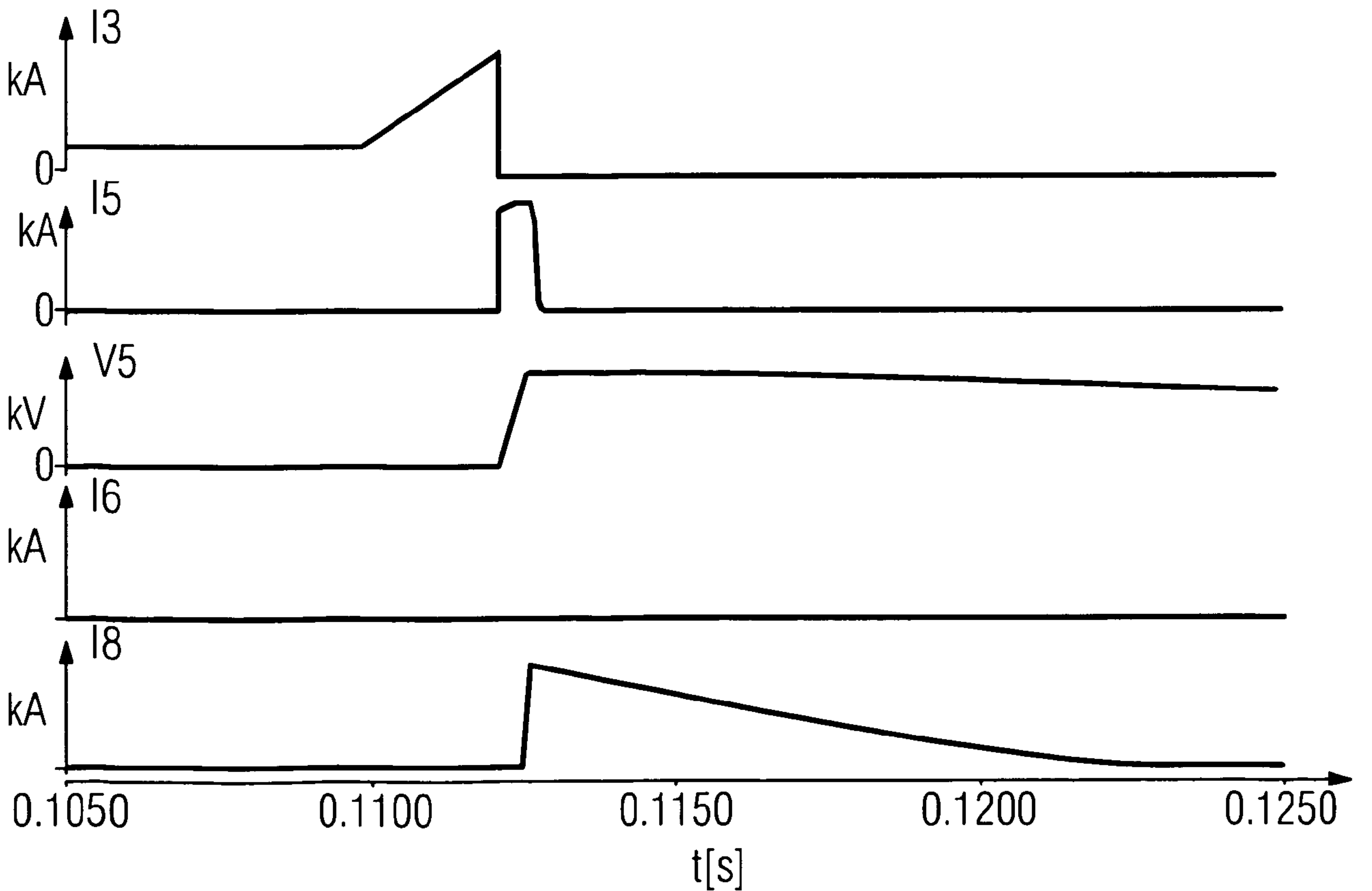

FIG 7

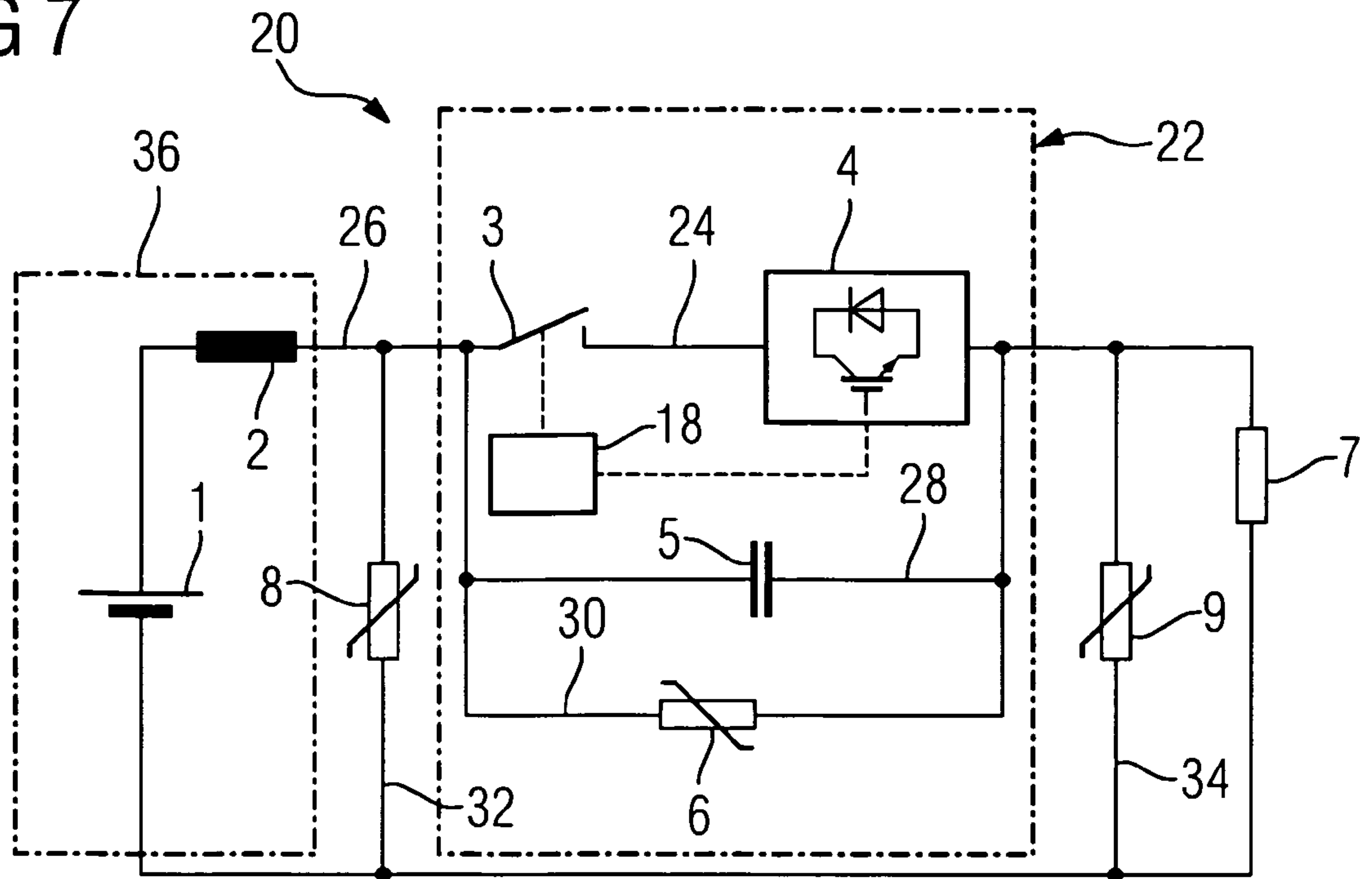

FIG 8

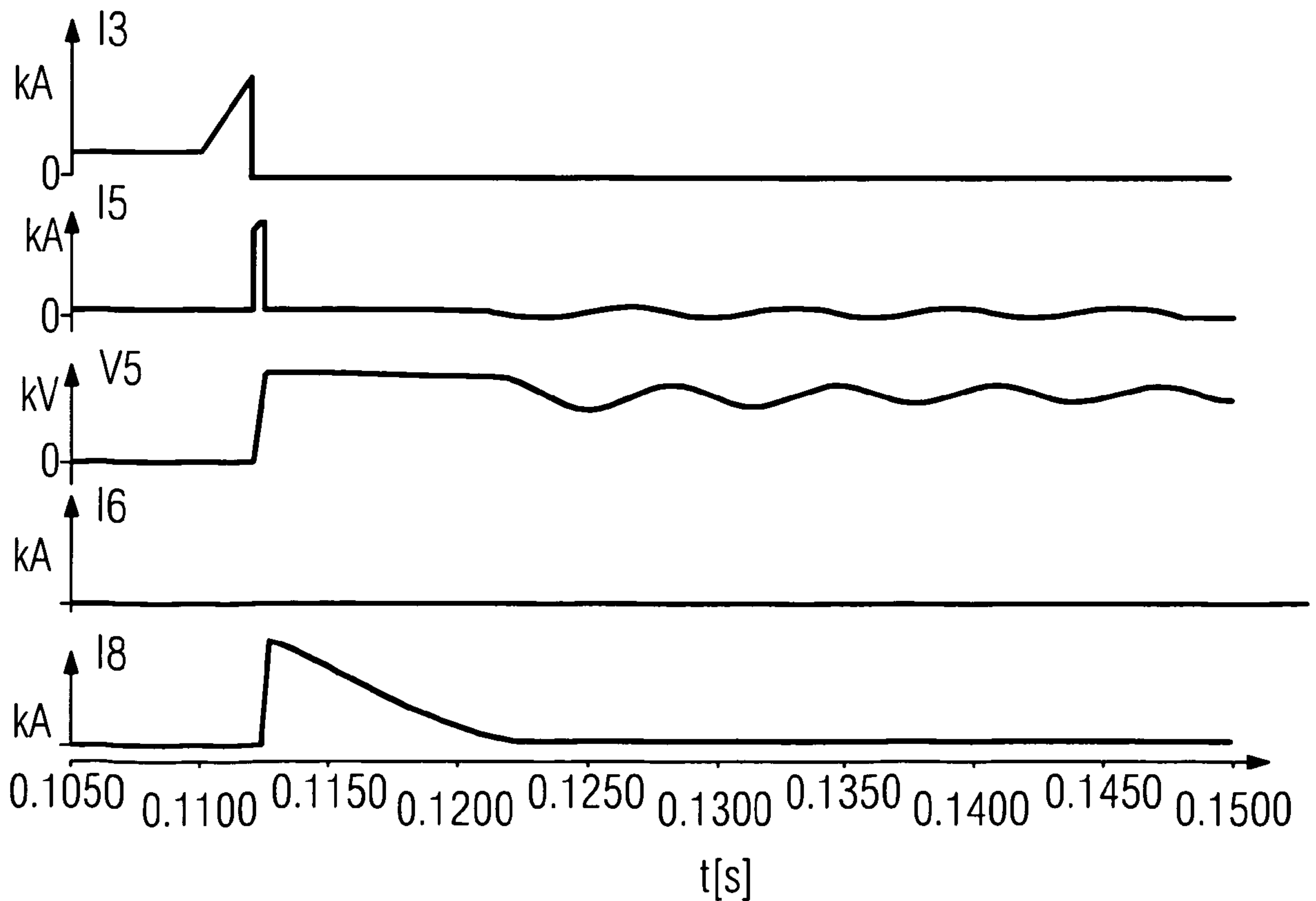

FIG 9

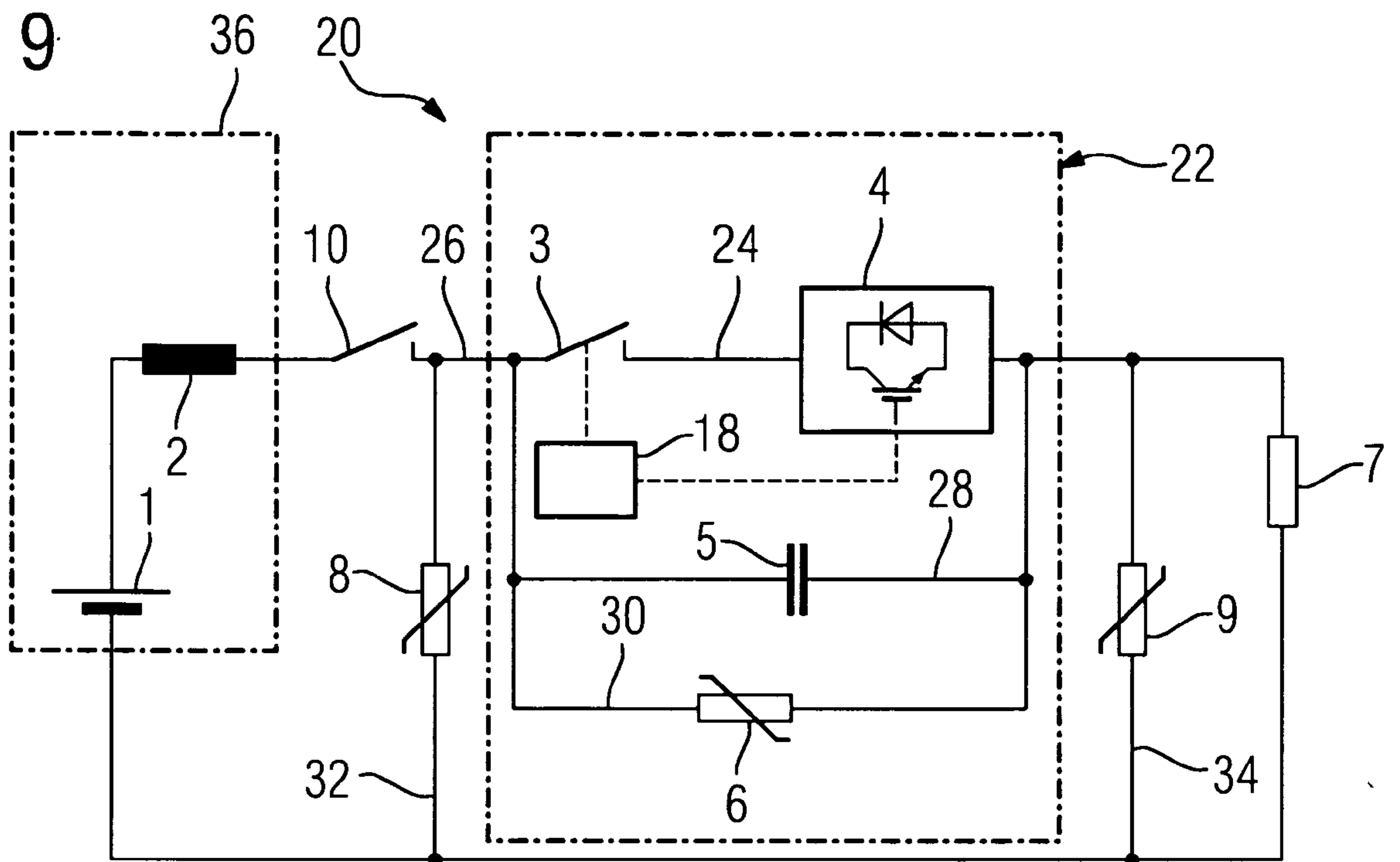

FIG 10

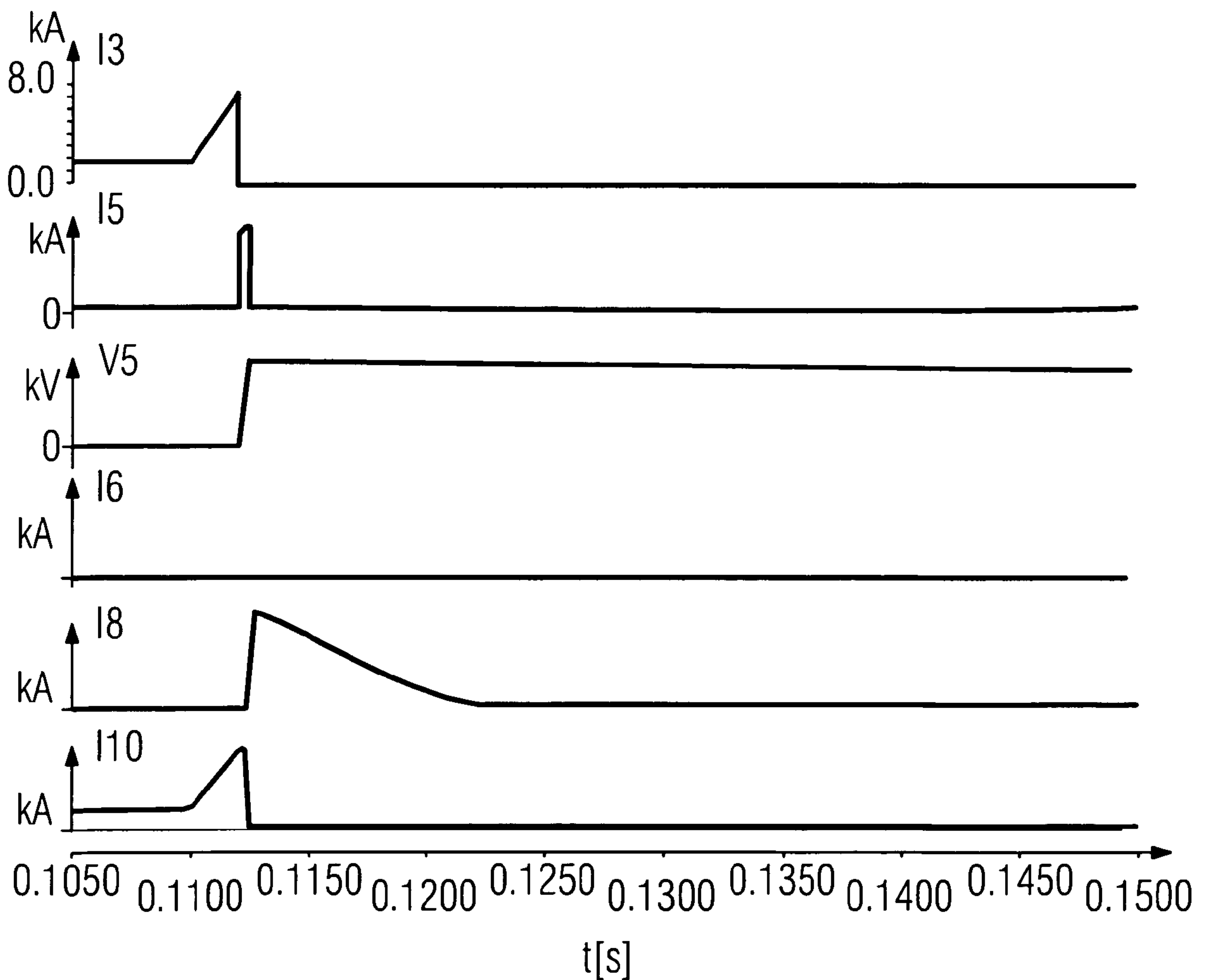

FIG 11

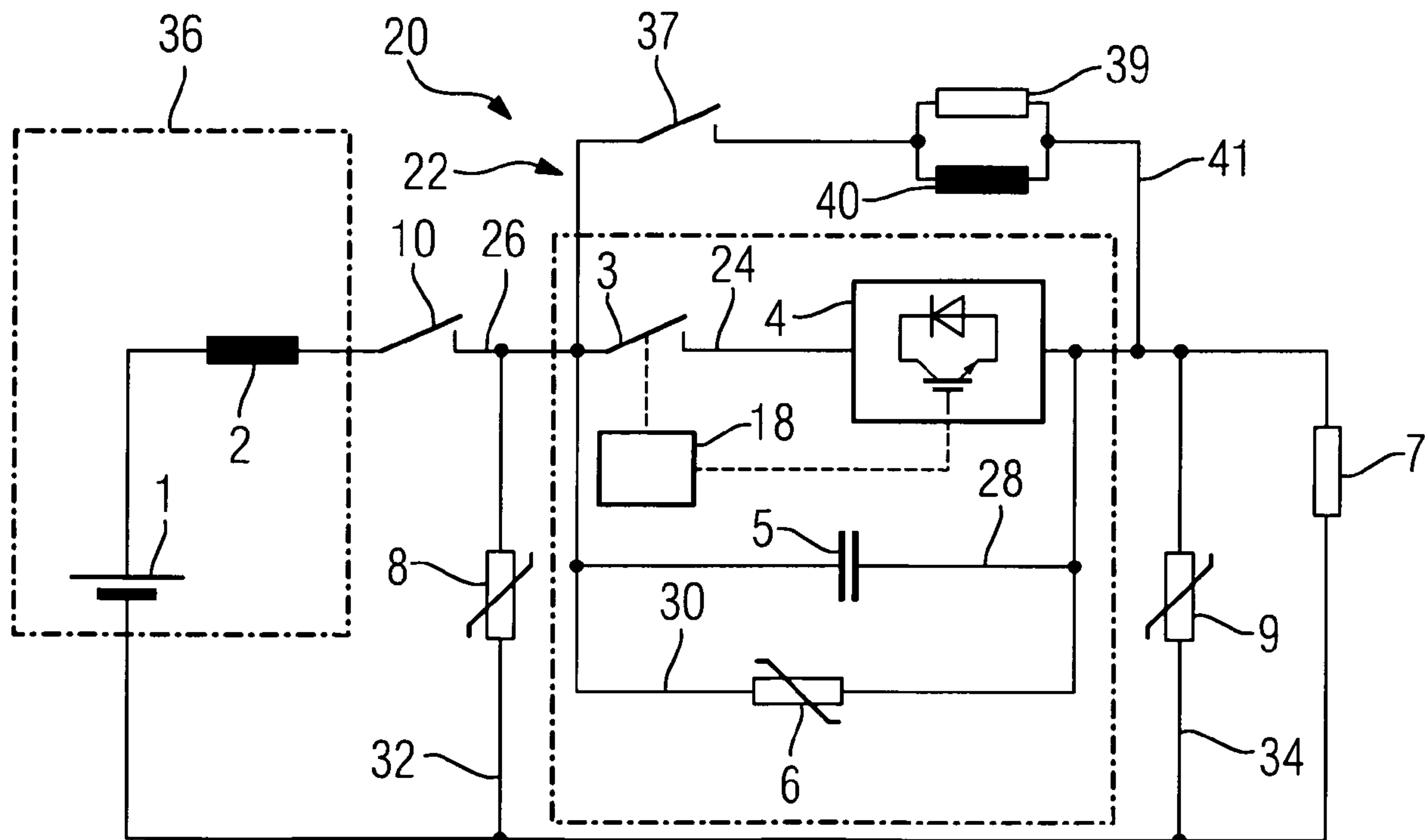

FIG 12

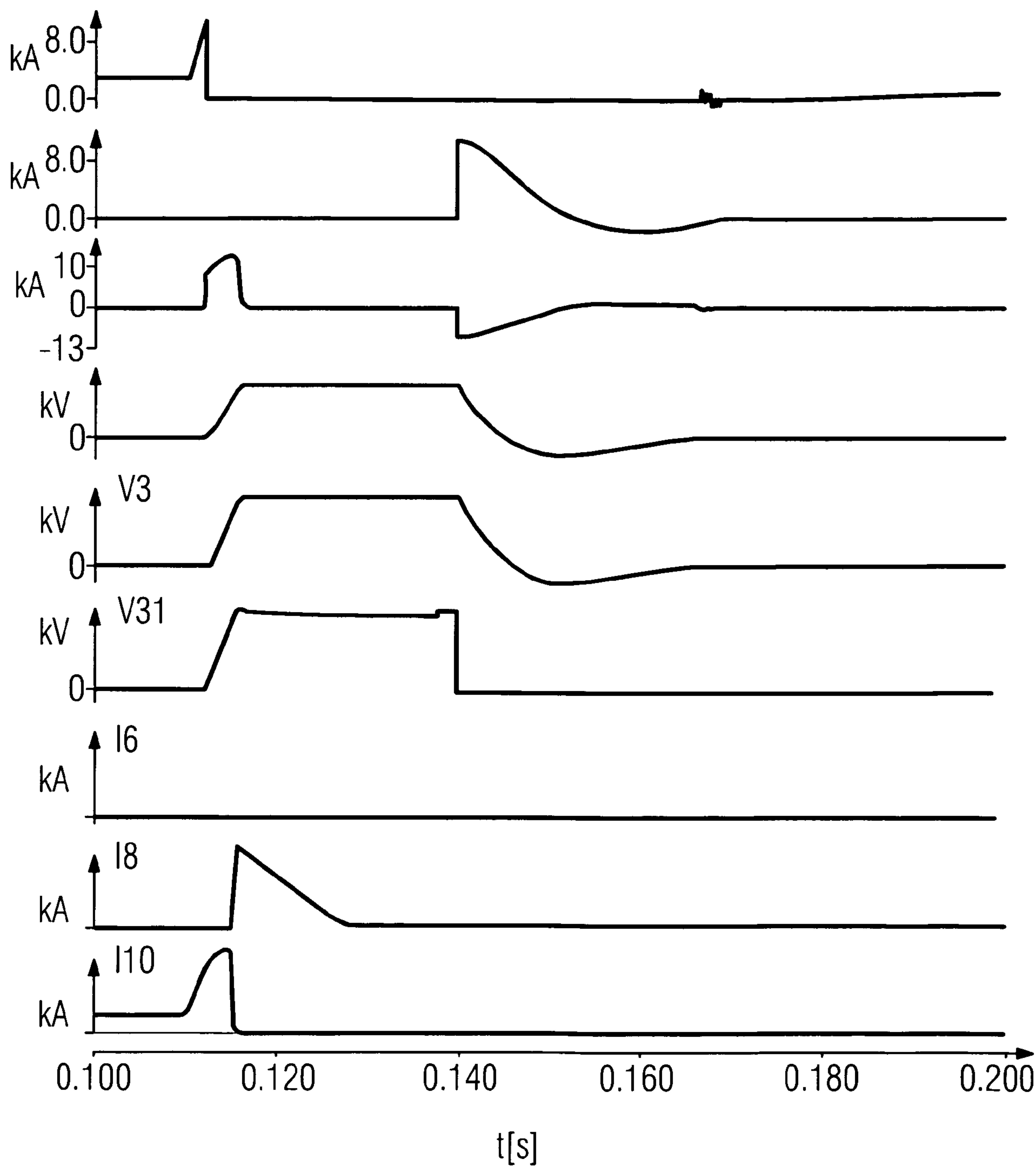

FIG 3

