



Office de la propriété
intellectuelle
du Canada

Un organisme
d'Industrie Canada

Canadian
Intellectual Property
Office

An Agency of
Industry Canada

(11) © **1,341,327**
 (21) 610,259
 (22) 1989/09/05
 (45) 2001/12/18
 (52) 204-22.6
 C.L. CR 204-22.7

(51) Int.Cl. ⁷ C25D 11/02; C23C 18/18; C25D 5/34

(19) (CA) **CANADIAN PATENT** (12)

(54) **Methods for Depositing Finish Coatings on Substrates of Anodisable Metals and the Products Thereof**

(72) Fern, Dan, CA
 Hanthorn, Christopher James, CA

(73) **ALCAN INTERNATIONAL LIMITED, CA**

(57) **23 Claims**

ABSTRACT

134 1327

610,259

New processes are disclosed for depositing metal coatings on substrates of anodisable metals, such as aluminum and its alloys, the coatings being applied directly on to a porous anodised layer of relatively wide pores that has been produced on the surface of the substrate by phosphoric acid anodisation. Pore-filling metal is first electrolytically deposited in the pores, the metal depositing initially on the bottom walls and the lower parts of the side walls; usually until the pores are from about 3% to about 30% filled. Metal deposition is then continued using an electroless process until the pores are filled to the desired extent, usually until a support coating has been applied over the entire anodised layer. Other metal coatings can then be applied over the support layer, either by electrolytic or electroless methods. Electroless coatings of considerable thickness (as much as 75 micrometres) can successfully be applied. The new products of such processes comprise a substrate of anodisable metal having on a surface an anodised layer of thickness of about 0.5 to about 50 micrometres; the pores of the anodised layer have pore-filling metal electrolytically deposited therein, and pore-filling metal electroless deposited on the electrolytically deposited metal. The electroless metal may constitute the final layer or other layers may be deposited over it to give the final product. The interposed electrolytically deposited metal provides improved adhesion to the anodised material as compared to direct electroless deposited metal.

METHODS FOR DEPOSITING FINISH COATINGS ON SUBSTRATES OF
ANODISABLE METALS AND THE PRODUCTS THEREOF

Field of the Invention

5 This invention is concerned with improvements in or relating to methods for depositing metal coatings on substrates of anodisable metals, such as aluminum and its anodisable alloys, and to the products of such methods.

Review of the Prior Art

10 The deposition of metals on a substrate, usually steel or aluminum, is a well-developed art. Plating on less easily oxidized metals such as steel is relatively routine, involving for example the deposition of a layer of copper directly on the steel substrate, followed in succession by a thick "semi-bright"
15 nickel layer, a thinner "bright" nickel layer, and an even thinner finish layer of chromium; the chromium is semi-transparent and the bright appearance is actually provided by the bright nickel layer seen through the finish chromium layer.

20 Plating on anodisable metals, such as aluminum and its anodisable alloys, is considerably more difficult owing to their relative ease of oxidation, and the consequent inevitable presence of an oxide coating which must be removed if adequate adhesion of the deposited layers to the underlying metal
25 substrate is to be obtained. The art currently is dominated by two methods of preparing the substrate surface, namely zincate and stannate immersion. In these processes the substrate surface is immersed in a suitable zincate or stannate solution, usually of the sodium salt, together with other additions that
30 have been found in practice to increase the appearance and adhesion of the coatings. The zinc or tin atoms respectively displace aluminum atoms at the surface, in the process removing the oxide layer, to result in an adherent zinc or tin layer on which other layers, for example copper followed by nickel and
35 chromium can be deposited. Both of these processes are relatively expensive and are therefore mainly used on expensive commodities. The stannate immersion processes are reported to provide better anti-corrosion performance and adhesion of the

resultant coatings, but are the more expensive of the two because of the more expensive components and longer processing times.

It has also been proposed to deposit adherent metal coatings directly on aluminum or aluminium alloy substrates by producing a porous anodized layer at the surface of the substrate onto which the subsequent metal layers are deposited; this anodized layer incorporating the oxide layer that was present on the substrate surface. In an article entitled "Plating on Aluminum, a Review" by D.S. Lashmore, published in the June 1985 issue of "Plating & Surface Finishing" (pp 36-39), summarizing previous publications, it was reported that studies have shown that there must be a minimum pore size in the anodized coating, into which the subsequent metal coatings can mechanically "lock" or "key", and that this limits the process to the use of electrolytes that will produce fairly large pores of the order of 0.07 micrometres (700 Angstroms). The report goes on to state it has been found empirically that only anodising solutions comprising phosphoric acid are successful, sulfuric or oxalic acid sometimes being mixed with the phosphoric acid. The report further states that the adhesion of the subsequent coatings is primarily mechanical, with the cohesive strength of the porous oxide coatings to the metal substrate being the limiting factor, so that improvements in the anodic process should be directed towards increasing this cohesive strength and the strength of the oxide layer itself. Despite developments of these phosphoric acid anodizing/coating processes for over 50 years they have not yet been widely adopted commercially, apparently because of relatively poor adhesion and brightness.

Definition of the Invention

It is therefore the principal object of the present invention to provide new methods for plating metal layers on substrates of aluminum and its alloys, and to provide substrates of aluminum and its alloys having metal layers plated thereon by the new methods.

In accordance with the present invention there is

provided a new method of depositing metal on a surface of a substrate of an anodisable metal, said method comprising:

5 a) anodising the substrate using phosphoric acid to produce a porous anodised layer which is of pore size greater than about 0.03 micrometre and of thickness from about 0.5 to about 50 micrometres;

b) electrolytically depositing pore-filling metal into the pores to adhere to the walls thereof and so as to fill each pore from about 3% to about 30% of its volume; and

10 c) continuing the deposition of pore-filling metal by electroless deposition on the electrolytically deposited metal to fill each pore to the required extent.

Also in accordance with the invention there is provided a metal plated product consisting of an anodisable metal substrate acid anodised to have a porous anodised layer and having metal deposited in the pores thereof wherein:

15 a) the anodised layer is phosphoric acid anodised to have pores of pore size greater than about 0.03 micrometre and to have a thickness of about 0.5 to about 50 micrometres;

20 b) the porous layer has pore-filling metal electrolytically deposited in the pores thereof so as to adhere to the walls thereof and fill each pore from about 3% to about 30% of its volume; and

25 c) the porous layer has pore-filling metal electrolessly deposited in the pores on the electrolytically deposited metal so as to fill each pore to the required extent.

Description of the Drawings

30 Methods of depositing various layers of metals on a surface of an anodisable substrate, and the products of such methods, constituting particular preferred embodiments of the invention, will now be described by way of example with reference to the accompanying drawings, wherein:-

Figure 1 is a plane cross-section through the surface and adjacent portion of an aluminum substrate, through the porous anodised layer formed thereon by phosphoric acid anodising, and through the various layers of metal that have
5 been deposited on the anodised layer; and

Figure 2 is a plane cross-section to a much enlarged scale of the small portion 2 in Figure 1, showing the anodised layer and the immediately adjacent metal layers.

10 Description of the Preferred embodiments

As indicated above, Figure 1 is a cross-section through an aluminum substrate 10 at the upper surface of which there has been formed by acid anodising a layer 12 of aluminum oxide, a portion of which, together with the immediately adjacent
15 portions of the substrate and deposited metal layers, are shown to a larger scale in Figure 2. The anodising employs phosphoric acid which produces elongated wide pores 14 (not seen in Figure 1), and in accordance with this invention at least the bottom portions of the pore walls have had applied thereto by
20 electrolytic deposition a layer of adherent pore-filling metal 16 (also not seen in Figure 1). The electrolytically deposited metal is found initially to deposit principally at the bottoms of the pores and the immediately adjacent parts of the side walls, and the resultant coatings or layers then grow
25 progressively in thickness upwards in the pores as more metal is deposited. It is also found initially that discontinuous patches 17 of the metal are deposited on the side walls in what appears at present to be a random manner. After sufficient metal has been electrolytically deposited the filling of the
30 pores is continued using electroless deposited metal 18 until, in this embodiment, they are completely filled and a continuous support layer has been formed over the entire surface of the anodised layer 12. In this embodiment cobalt is used as the initial electrolytically deposited metal 16 and 17, while
35 electroless nickel is employed for the metal 18. The deposition of metal layers is continued to provide a semi-bright nickel layer 20, a bright nickel layer 22 and a tri-chrome finish layer 24.

The invention thus employs the electrolytic deposition of pore filling metal to apply an initial "seed" coating to the bottom wall portion of each pore and to at least the lower portion of the side wall of each pore. It is found that such an electrolytically deposited metal coating adheres very well to the anodised material, and the subsequently electroless deposited metal adheres very well to the electrolytically deposited metal, whereas metals deposited by electroless processes directly on aluminum oxide do not adhere well and result in lower strength metal coatings. Electroless coating processes have the advantage that they are more efficient than electrolytic processes in filling the pores and result in more dense or compact coatings, and the processes of the invention enable advantage to be taken of this property while overcoming the potential problem of insufficient adherence of the electroless deposited metal to the anodised layer.

The anodised layer is inherently porous in structure because of the manner of its formation, and a typical structure of a layer 12 obtained by phosphoric acid anodising of the aluminum substrate 10 is illustrated by Figure 2. For convenience in drawing the horizontal surfaces of the layers are shown as flat, but in practice they will be seen to be highly irregular even at quite low magnification.

Figure 1 illustrates an embodiment in which an anodised layer 12 of aluminum oxide (Al_2O_3) has been produced of about 2 micrometres (20,000 Angstroms) thickness, typically by use of phosphoric acid at about 20°C and of about 109g/litre or 10% by weight concentration, employing an anodising voltage of about 50-60 volts for 10 minutes. The porous structure obtained is relatively uniform, although highly idealised as shown in Figure 1 for convenience in drawing, and typically the pores 14 will be found to average 0.09 micrometre (900 Angstroms) in transverse dimension, spaced on average about 0.07 micrometre (700 Angstroms) from one another. The pores have an average length/width ratio of 20:1. The bottoms of the pores do not end at the surface of the aluminum substrate, but instead they are on average spaced about 0.07 micrometre (700 Angstroms) from that surface to form a continuous non-porous barrier layer 26 of

the relatively non-conductive aluminum oxide, the thickness of this layer depending principally directly on the value of the anodising voltage. It may be noted that references herein and in the literature to pore sizes, etc. are usually made in
5 Angstroms, while references to thicknesses are made in micrometres, merely to avoid the need to refer to large numbers or small fractions, 1 micrometre being equal to 10,000 Angstroms.

It has been found possible in previous commercial practice with sulfuric acid anodising that produces long narrow
10 pores of average transverse dimension 0.015 micrometre (150 Angstroms) to deposit pore filling metal layers that are sufficiently strong and stable of up to about 5 micrometres thickness, but beyond this value the hydrogen that is generated in the long, narrow pores (i.e. length to width ratio of about
15 330:1) by the electrolytic deposition process tends to cause spalling of the anodised coating, destroying its strength to the extent that it is unsuitable to receive and retain the pore filling metal. Another problem is that it is difficult to deposit a sufficiently adherent coating of a pore-filling metal
20 into the long narrow pores employing conventional D.C. plating methods. Thus, there is too great a tendency for the plating step to cause physical disruption of the anodised layer, so that the plated metal layer is poorly adherent.

Metal deposition processes may use either alternating
25 current or direct current, or a combination thereof. A.C. deposition is usually much slower than the equivalent D.C. current and D.C. is therefore preferred if speed is important. However, D.C. has a greater tendency to cause disruption of the coating especially with the narrow pores characteristic of
30 sulfuric acid anodising. It is therefore also known to use modified A.C., preferably one in which a predetermined negative-going D.C. has been superimposed on the A.C. Such a system avoids the disruption that would be produced by a pure D.C. current. A.C. produces metal deposition owing to the
35 rectification characteristic of the aluminum oxide, but as the thicknesses of the coatings increase such unmodified A.C. deposition gives poorer pore penetration and slower deposition rates. The D.C. component is therefore increased to the maximum level that does not cause disruption. This method of deposition

is disclosed for example in U.S. Patent No. 4,226,680, assigned to Alcan Research and Development Limited; these processes have now become known as the Alcan "ANOLOK" (Trade Mark) processes. Other modified A.C. systems are also possible; for example,
5 another system offsets the A.C. waveform in a manner that will produce an effective negative bias, while a further way is to increase the amplitude of the negative portion of the waveform relative to that of the positive portion, which again has the same effect.

10 The processes of the invention are applicable generally to anodisable metals, their alloys and composites; whether rolled, pressed, cast or wrought. Cast metals are generally less dense and more porous in structure than the corresponding
15 rolled, pressed or wrought product. Attempts to use only electroless deposition, or only electrolytic deposition, directly on the anodised surface of a cast material have not been as successful as the processes of the invention because of this higher porosity and because of the usual higher silicon
20 content (e.g. 7-12%) of such metals. Thus, the more porous metal structure results in anodised layers of lower strength and quality, and electrolytic deposits are more adversely affected by the anodic layer quality than are electroless layers, it is believed because of entrapment of some of the silicon in the
25 barrier layer which interferes with the normal flow of electrons in the deposition current. On the other hand, as explained above, layers applied by direct electroless deposition are generally poorly adherent to the already lower strength anodised layer.

Suitable substrate metals, in addition to aluminum and
30 its anodisable alloys, are magnesium and its anodisable alloys. Metals suitable for the electrolytic deposition of the initial "seed" layer are cobalt, nickel, zinc, copper, tin and palladium. When the substrate is aluminum or an alloy thereof cobalt has been found to be particularly suitable for
35 electrolytic deposition and nickel for electroless deposition.

It is found that as the thickness of the electrolytic layers within the pores increases a point may be reached at

which the adhesion to the aluminum begins to decrease, and this then sets an upper limit at which the electrolytic deposition should be stopped and replaced by the electroless deposition. Of course the electrolytic deposition can be discontinued earlier depending upon the other parameters of the particular process. It is found that the thickness of the initial seed coatings, as measured from the bottom of the pores, correlates well with the apparent colour of the substrate surface as seen by an observer, and the table below shows a specific correlation that is obtained when the anodised layer that has been produced by sulfuric acid anodising is 5 micrometres thick; the electrodeposited metal is cobalt. The same principle applies with phosphoric acid anodising but the colours obtained are slightly different. The thickness of the electrolytically deposited metal is most expeditiously expressed in the units milligrams (mg) of metal per square metre (m^2) of anodic surface. It is found with this combination that the cut-off for good adhesion is between about 550 and about 850 mg/m^2 .

20

TABLE

<u>Colour</u>	<u>mg Co/m²</u>	<u>%Fill</u>	<u>Adhesion</u>
Champagne	70	3.5	good
Very Light Bronze	180	9.0	good
Light Bronze	340	17.0	good
25 Medium Bronze	550	27.5	good
Dark Bronze	850	42.5	poor
Black	2000	100.0	poor

It will be seen that as little as about 3% will give good adhesion and this is the minimum value for satisfactory results, while at the upper thickness limit of medium bronze for pores of 5 micrometres depth it is estimated that each pore is about 30% filled in volume with the electrolytically deposited metal, leaving the remaining 70% to be filled with the electroless deposited metal. Nickel is found to produce

35

approximately the same colour correlation as cobalt. Copper produces a range of different colours extending from pink through light maroon and dark maroon to black. Tin requires a thicker anodised coating of about 10 micrometres before black is
5 obtained.

The amount of electroless applied metal that is deposited in the pores will of course depend upon the required properties and intended use of the resultant product, and for some applications the pores may not need to be completely
10 filled; from about 6% to about 60% of complete filling may be all that is required. Thus, while a useful range for the electrolytic deposition is about 3% to about 30%, a useful range for the electroless deposition is also from about 3% to the remainder required to fill the pores to the required extent.

15 Once the initial electrolytic seed deposit and the subsequent electroless deposit have been applied the subsequent processing steps will also depend upon the commercial application of the resultant product and the characteristics and appearance that are required. For example, the electroless
20 deposition can simply be continued until a final layer (over the anodised layer) of adequate thickness is obtained, the usual range for such an application being from about 50 micrometres to about 75 micrometres. More usually the electroless deposition is continued until it forms a support layer of adequate
25 thickness over the entire surface of the anodised layer, as illustrated by Figures 1 and 2, the usual values being from about 0.5 micrometre to about 3 micrometres, more preferably in the range 1-2 micrometres. Thereafter, a finish layer (for example chromium) may be applied over the support layer, with or without
30 the provision of one or more intermediate layers between the support and finish layers.

The use of phosphoric acid is found to be particularly advantageous with cast materials, and it has been found for
35 example that the cast aluminum such as is used for automotive wheels the adhesion of the final coating/s was increased by at least 50% upon use of phosphoric acid in place of sulfuric acid

for the anodising. A suitable test for adhesion is to cut the finished part through the substrate and coatings and then to attempt to lift or peel the coating away from the substrate by use of a sharp knife edge; it was found possible with this test to peel the coatings from sulfuric acid anodised substrates with various degrees of difficulty depending on the processing conditions, but not possible to peel it from phosphoric acid anodised substrates.

The use of an anodised layer before plating introduces the possibility, if desired, of a reduction in the thickness of the subsequent plated layers with consequent cost savings. The anodising processes described employing acid baths in the temperature range of 20-35°C are usually characterised as "conventional" anodising, but "hard anodising" processes can also be employed for the invention, the usual bath temperature being in the range 3-7°C; such hard anodised layers are usually thicker than the conventional anodised layers. Further reductions in the subsequent layers therefore are possible by using a thicker and/or stronger anodic film such as that produced using these lower temperature anodising processes. Such hard layers also constitute an excellent basis for the pore-filling metal deposition characteristic of the invention, the electroless layer being the support layer for further deposits, which can be thinner than those normally previously used. It will be understood that this industry is particularly cost conscious, especially with regard to the relatively expensive corrosion-resistant metals that are employed in the intermediate and finish coatings, so that any saving that can be achieved in their thickness for an equivalent performance in protection and/or appearance is commercially important.

In the processes of the invention the anodised layer can be of a thickness in the range 0.5 - 50 micrometres, usually in the range 1-10 micrometres, preferably in the range 2-6 micrometres, and more preferably 3-5 micrometres, with a thickness of 5 micrometres being usually commercially suitable. The electroless-deposited pore-filling material need not form a

support coating of more than about 2 micrometres thickness and excellent results can be obtained with the application of a single thin finish coating of chromium over the support layer. The preferred electroless deposited metal is nickel. Metals
5 other than nickel, such as cobalt, tin or copper, can also be used. Because of the thin coatings that are employed it is preferred in some processes to pre-treat the surface of the anodisable metal to obtain a very smooth surface; this can be a "macro" treatment by buffing and/or a "micro" treatment of
10 chemical or electro-brightening. The finished chromium layer if provided preferably is of thickness in the range of 0.2-0.3 micrometres.

The invention is further illustrated by the following specific example:

15 Example 1

The process is employed to provide a bright finishing procedure for articles such as cast aluminum automotive wheels, giving a simulation of the appearance of bright chrome or stainless steel, and includes the following steps.

20 1. An aluminum substrate consisting of cast alloy A413, or forge grade material, is pre-treated by cleaning with appropriate alkaline and/or acid solutions, or is pretreated by mechanical buffing.

25 2. The pretreated substrate is then subjected to a phosphoric acid anodising treatment using acid of 109g/L (10%) concentration by weight at 21°C; the anodising is begun at 60VDC for 30 minutes and is then ramped down to approximately 18 VDC for about 0.5 minute.

30 3. The anodised substrate has the initial "seed" electrolytic coating of cobalt applied using a cobalt-based "ANOLOK" (trade mark) electrolyte as disclosed in U.S. Patent No. 3,616,309 at 21°C and 12.5 V.A.C., with or without up to 4 V.D.C. bias. The electrolytic deposition proceeds for a period of about one minute.

35 4. A pore-filling coating of nickel is then applied by immersion in an electroless nickel solution (Harshaw "Alpha

103B" - trade mark) for 20 minutes at pH4.7 and temperature 93°C, thus completely filling the pores and forming a support coating of about 0.5 to about 3.0 micrometres thickness

5. The support layer is coated with an
5 electrolytically-deposited semi-bright layer of nickel of about 10 micrometres thickness using Harshaw "PERFLOW" (trade mark) semi-bright solution at pH4.3; temperature 57°C; current density 5 amps per square decimetre (A/dm^2); and for a period of thirty minutes.

10 6. The semi-bright layer is coated with a bright layer of nickel of about 10 micrometres thickness using Harshaw "SUPREME" (trade mark) bright solution at pH4.0; temperature 66°C; current density $4A/dm^2$ and period 10 minutes.

15 7. The example is completed by electrolytically depositing a trichrome finish layer using Harshaw "TRI-CHROME PLUS" (trade mark) solution at pH2.7; temperature 30°C; current density $10 A/dm^2$ for 5 minutes.

20 During the process the substrate will be rinsed in known manner which need not be detailed here. It may be noted that in this and the other examples described a cyanide or hexavalent chromium bath is not used, which is environmentally desirable.

Example 2

25 In the process of Example 1 the cobalt-based electrolyte employed to deposit the initial layer is replaced with a copper-based electrolyte comprising for example 35g/l of $CuSO_4 \cdot 5H_2O$; 20g/l $MgSO_4 \cdot 7H_2O$ and 5g/l H_2SO_4 at pH 1.3 and 21°C.

Example 3

30 In the process of Example 1 the cobalt-based electrolyte employed to deposit the initial layer is replaced with a tin-based electrolyte comprising for example 10g/l of $SnSO_4$ and 20g/l of H_2SO_4 at pH 1.3 and 21°C.

Example 4

35 In the process of Example 1 the cobalt-based electrolyte employed to deposit the initial layer is replaced

with a conventional Watt's nickel-based electrolyte comprising for example 240g/l of $\text{NiSO}_4 \cdot 6\text{H}_2\text{O}$; 60g/l of $\text{NiCl}_2 \cdot 6\text{H}_2\text{O}$ and 45g/l of H_3BO_3 at pH 4.5 and 21°C.

Example 5

5 In the process of Example 1 the cobalt-based electrolyte employed to deposit the initial layer is replaced with a palladium-based electrolyte comprising for example a 10 ml/litre "PALLAMERSE" (trade mark) aqueous solution of Technic Inc. This process is particularly suited for articles with a
10 simulated stainless look for exterior application.

Example 6

To obtain a bright black finish, especially for cast aluminum automobile wheels, the process of any of of examples 1 through 5 is followed by the deposition of a black-chrome finish
15 layer using Harshaw "CHROMONYX" (trade mark) solution at temperatures 21°C; current density 10-40 A/dm^2 and period of 5 minutes.

Example 7

20 To obtain articles with a simulated appearance of stainless steel and for interior applications a substrate cast alloy is subjected to the processes of any one of examples 1 through 5 with the omission of the deposition of the semi-bright nickel layer.

Example 8

25 To obtain machine parts and articles suitable for other engineering applications the anodising and electrolytic deposition steps of any one of examples 1 through 5 are followed by a nickel electroless deposition step in which the deposition period is about 30 minutes to about 120 minutes, as required, to
30 give layers of about 10.0 micrometres to about 40.0 micrometres thickness.

Example 9

To obtain black material particularly suitable for the fabrication of solar panels a substrate is subjected to the
35 anodising, initial electrolytic plating and electroless plating steps of any one of examples 1 through 5, followed by the

deposition of semi-bright nickel for a reduced period of about 10 to about 20 minutes, and the deposition of black chrome by the step in example 6.

Example 10

- 5 Bright aluminum plated composite articles are prepared from a substrate of composite material AA-6061 (incorporating 10% by weight of aluminum oxide) using the plating procedure of any one of examples 1 through 5.

CLAIMS:

1. A method of depositing metal on a surface of a substrate of an anodisable metal, said method comprising:
 - a) anodising the substrate using phosphoric acid to produce a porous anodised layer of which is of pore size of transverse dimension greater than about 0.03 micrometre and of thickness from about 0.5 to about 50 micrometres;
 - b) electrolytically depositing pore-filling metal into the pores to adhere to the walls thereof and so as to fill each pore from about 3% to about 30% of its volume; and
 - c) continuing the deposition of pore-filling metal by electroless deposition on the electrolytically deposited metal to fill at least 3% of the volume of each pore.
2. A method as claimed in claim 1, wherein the anodisation produces pores of transverse dimension from about 0.03 to 0.10 micrometre.
3. A method as claimed in claim 1, wherein the electrolytic deposition is continued to a cut-off value at which adhesion of the metal begins to decrease.
4. A method as claimed in claim 3, wherein the electrolytically deposited pore-filling metal is deposited to a thickness of up to 550 milligrams per square metre.
5. A method as claimed in any one of claims 1 to 4, wherein the electroless deposition is continued until a coating of the metal of thickness in the range of about 0.5 to 3 micrometres is deposited on the surface of the anodised layer.

6. A method as claimed in claim 5, wherein the electroless deposited metal is deposited to form a support layer on the surface of the substrate of a thickness in the range of about 0.5 to 3 micrometres, and in that one or more subsequent layers are deposited on the support layer.

7. A method as claimed in any one of claims 1 to 4, wherein the electroless deposited metal is deposited to a thickness of about 10 to 25 micrometres on the surface of the substrate.

8. A method as claimed in any one of claims 1 to 4, wherein the anodisable substrate metal is selected from aluminum and magnesium and an anodisable alloy thereof.

9. A method as claimed in any one of claims 1 to 4, wherein the anodisable metal is selected from cast aluminum and an alloy thereof.

10. A method as claimed in any one of claims 1 to 4, wherein the electrolytically deposited pore-filling metal is selected from nickel, cobalt, zinc, copper, tin, palladium and an alloy thereof.

11. A method as claimed in any one of claims 1 to 4, wherein the electroless pore-filling metal is selected from nickel, cobalt, copper, tin and an alloy thereof.

12. A method of depositing metal on a surface of a cast aluminum substrate, said method comprising:

a) anodising the cast aluminum substrate using phosphoric acid to produce a porous anodised layer which is of pore size of transverse dimension greater than about 0.03 micrometre and a thickness from about 0.5 to about 50 micrometres;

b) electrolytically depositing pore-filling metal into the pores to adhere to the walls thereof and so as to fill each pore from about 3% to about 30% of its volume; and

c) continuing the deposition of pore-filling metal by electroless deposition on the electrolytically deposited metal to fill at least 3% of the volume of each pore.

13. A metal plated product consisting of an anodisable metal substrate anodised by acid so as to have a porous anodised layer and having metal deposited in the pores thereof, wherein:

a) the anodised layer is phosphoric acid anodised to have pores of transverse dimension greater than about 0.03 micrometre and to have a thickness of about 0.5 to about 50 micrometres;

b) the porous layer has a pore-filling metal electrolytically deposited in the pores thereof so as to adhere to the walls thereof and fill each pore from about 3% to about 30% of its volume; and

c) the porous layer has pore-filling metal electrolessly deposited in the pores on the electrolytically deposited metal so as to fill at least 3% of the volume of each pore.

14. A product as claimed in claim 13, wherein the substrate has been anodised to produce pores of transverse dimensions from about 0.03 to 0.10 micrometre.

15. A product as claimed in claim 13, wherein the electrolytically deposited pore-filling metal is deposited to a thickness of up to 550 milligrams per square metre.

16. A product as claimed in claim 13, wherein the electroless metal is sufficiently thick to form a coating deposited on the surface of the anodised layer.

17. A product as claimed in claim 16, wherein the electroless deposited metal is deposited to a thickness of about 10 to 25 micrometres on the surface of the substrate.

18. A product as claimed in any one of claims 13 to 16, wherein the electroless deposited metal is deposited to form a support layer on the surface of the substrate of a thickness in the range of about 0.5 to 3 micrometres, and in that one or more subsequent layers are deposited on the support layer.

19. A product as claimed in any one of claims 13 to 16, wherein the anodisable substrate metal is selected from aluminum and magnesium and an anodisable alloy thereof.

20. A product as claimed in any one of claims 13 to 16, wherein the anodisable metal is selected from cast aluminum and an alloy thereof.

21. A product as claimed in any one of claims 13 to 16, wherein the electrolytically deposited pore-filling metal is selected from nickel, cobalt, zinc, copper, tin, palladium and an alloy thereof.

22. A product as claimed in any one of claims 13 to 16, wherein the electroless pore-filling metal is selected from nickel, cobalt, copper, tin and an alloy thereof.

23. A metal plated product consisting of a cast aluminum substrate acid anodised to have a porous anodised layer and having metal deposited in the pores thereof wherein:

a) the anodised layer is phosphoric acid anodised to have pores of pore size in transverse dimension greater than about 0.03 micrometre and of thickness of about 0.5 to about 50 micrometres;

b) the porous layer has pore-filling metal electrolytically deposited in the pores thereof so as to adhere to the walls thereof and so as to fill each pore from about 3% to about 30% of its volume; and

c) the porous layer has pore-filling metal electrolessly deposited in the pores on the electrolytically deposited metal so as to fill at least 3% of the volume of each pore.

//

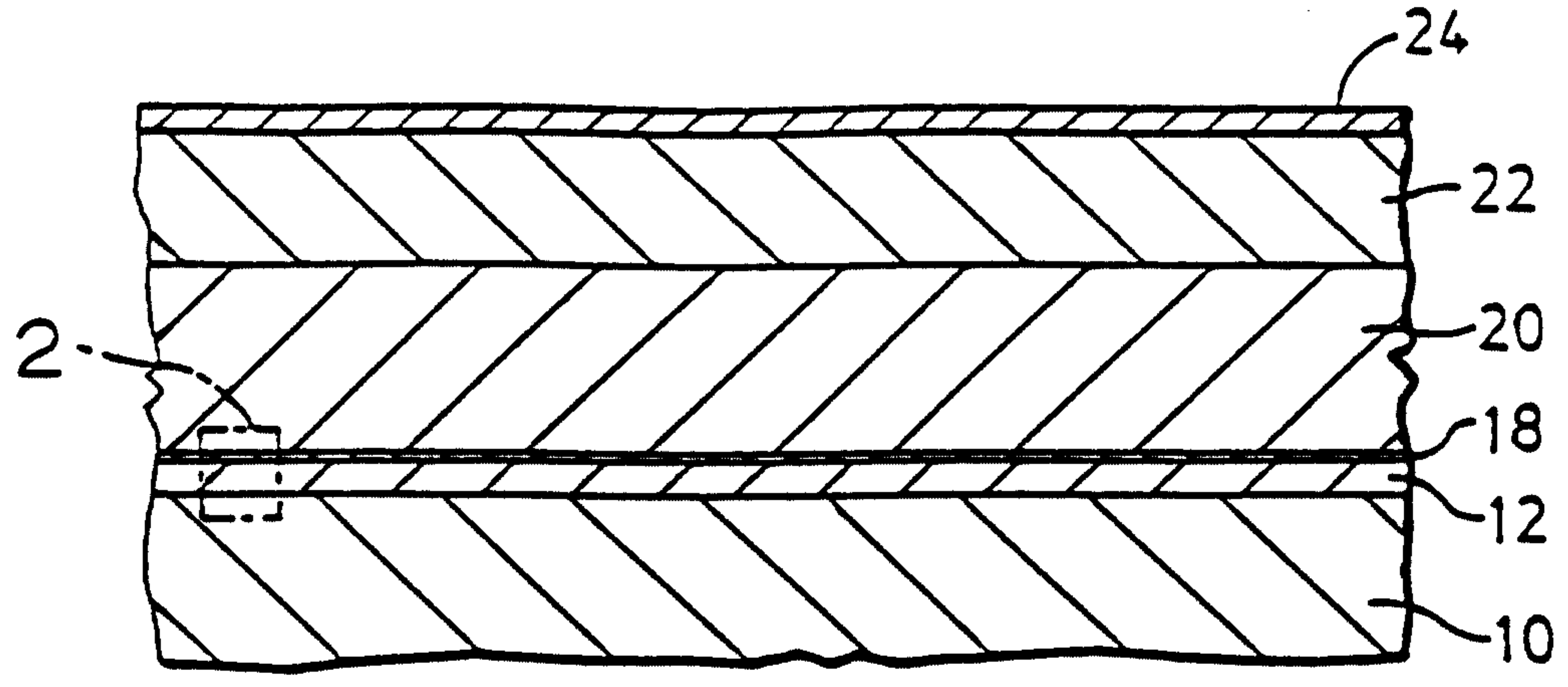

FIG. 1

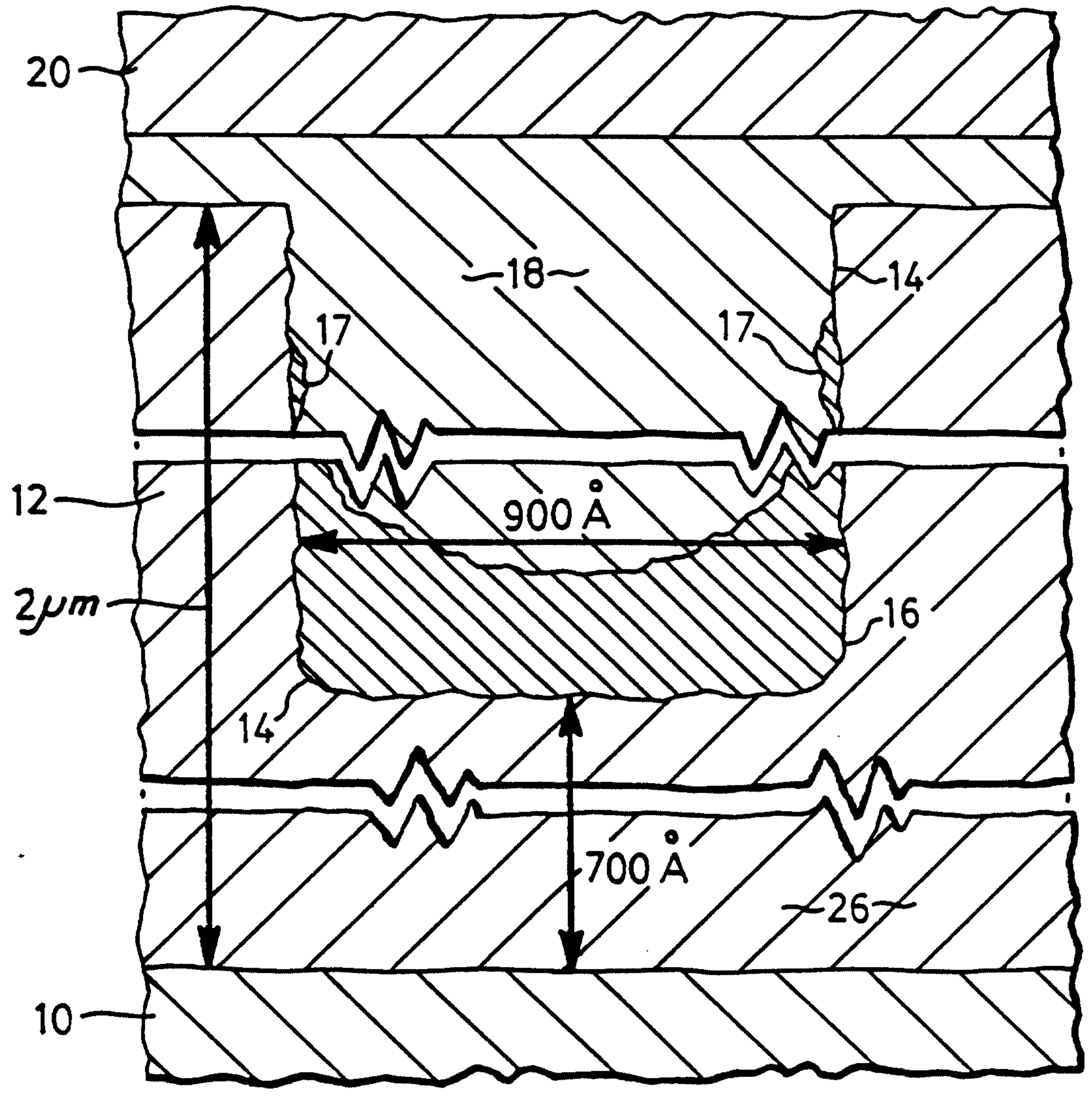

FIG. 2

Ray & Smith
Agents for the Applicant/s