

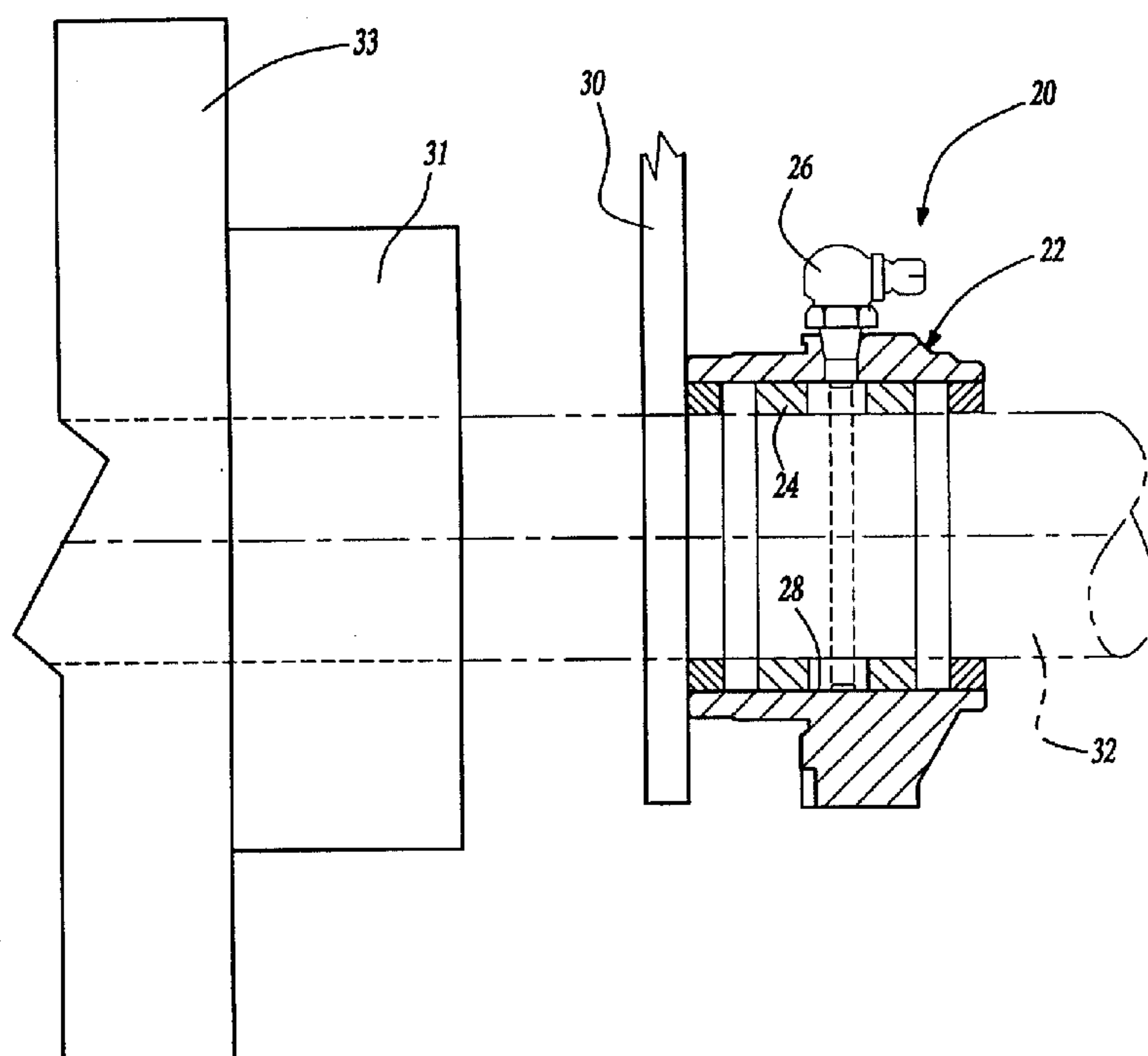

(72) DELEEuw, WILLIAM L., US
(72) PFISTER, DAVID K., US
(71) MERITOR HEAVY VEHICLE SYSTEMS, LLC, US
(51) Int.Cl.⁷ F16D 65/02, F16D 51/16
(30) 1999/04/06 (09/287,081) US
(54) **BAGUE DE CAME POUR SYSTEME DE FREIN A CAME**
(54) **CAM BUSHING FOR CAM BRAKING SYSTEM**



(57) A cam bushing assembly for supporting a camshaft in a cam braking system on a vehicle has a bushing retainer removable from a brake spider, and a bushing removable from the bushing retainer. The bushing retainer is bolted to the brake spider and can be removed simply by unfastening the bolts. A bushing is removably disposed within the bushing retainer. The bushing can be removed from the bushing retainer without removing the retainer from the brake spider. Further, the bushing assembly incorporates strategically located grooves that significantly increase lubricant flow to and around the camshaft.

Attorney Docket No. 98 AUT 083

CAM BUSHING FOR CAM BRAKING SYSTEM**ABSTRACT OF THE DISCLOSURE**

A cam bushing assembly for supporting a camshaft in a cam braking system on a vehicle has a bushing retainer removable from a brake spider, and a bushing removable from the bushing retainer. The bushing retainer is bolted to the brake spider and can be removed simply by unfastening the bolts. A bushing is removably disposed within the bushing retainer. The bushing can be removed from the bushing retainer without removing the retainer from the brake spider. Further, the bushing assembly incorporates strategically located grooves that significantly increase lubricant flow to and around the camshaft.

CAM BUSHING FOR CAM BRAKING SYSTEM

BACKGROUND OF THE INVENTION

This invention generally relates to a cam bushing assembly for a cam braking system. More particularly, this invention relates to a removable, detachable multiple-component cam bushing assembly. The assembly fits on the brake spider as part of a cam braking system.

There are two main functions of a cam bushing assembly. The primary purpose of a cam bushing is to support the camshaft in a brake spider housing. A secondary purpose of a cam bushing assembly is to allow for lubrication of the camshaft so that it can freely rotate.

Broadly speaking, there are two known types of brake camshaft bushing assemblies. Each has its own disadvantages.

A first type has a bearing retainer portion either welded to a brake spider or formed integrally with the spider. The bushing is removably placed in the retainer. However, the retainer may sometimes wear, and require replacement. With this type of assembly, the entire spider must be replaced. Also, it is desirable to pivot the camshaft for removal. However, the camshaft cannot be pivoted in a non-removable retainer. Thus, to remove the camshaft in this type of assembly, the wheel hub must be removed. This is undesirable.

A second type of bearing assembly has a one-piece retainer/bushing bolted to the spider. With this assembly, the bushing is integral to the retainer and cannot be removed. This is undesirable since it would be cheaper to simply replace the bushing. Also, the retainer is typically bolted to the spider with a closely controlled torque. It would be desirable to not need to replace the retainer, and achieve the torque load every time the bushing wears.

One other disadvantage of the single piece cam bushing is insufficient flow of lubrication to the camshaft. The use of the fixed components makes formation of lubricant passages quite difficult.

Attorney Docket No. 98 AUT 083

SUMMARY OF THE INVENTION

The cam bushing assembly of the present invention overcomes the above problems of single piece cam bushings. In general terms, this invention discloses a cam bushing assembly that includes a bushing retainer having an aperture and a bushing disposed within the aperture. The bushing retainer is removably attached to the brake spider and the bushing is removably attached to the retainer.

The bushing assembly is serviceable in several ways. The bushing itself can be removed from the retainer without removing the retainer from the brake spider. This is advantageous because the bolts that fasten the retainer to the brake spider, which are torqued to a predetermined value, do not have to be removed. Alternatively, the whole bushing assembly can be removed by unfastening the bolts. Since each component is individually removable, maintenance costs and time are minimal.

These and other features of this invention can be best understood from the following specification and drawings. Moreover, the use of the two removable components facilitates the inclusion of lubricant grooves. Thus, the present invention also ensures good lubricant flow.

BRIEF DESCRIPTION OF THE DRAWINGS

Figure 1 is a side view of a system designed according to this invention.

Figure 2 is a perspective view of a system designed according to this invention.

Figure 3 is a front view of a system designed according to this invention.

Figure 4 is an exploded perspective view of a system designed according to this invention.

Attorney Docket No. 98 AUT 083

DETAILED DESCRIPTION OF THE PREFERRED EMBODIMENT

Figure 1 schematically illustrates a cam bushing assembly, generally shown at 20. The bushing assembly 20 includes a bushing retainer 22, a bushing 24, and a grease fitting 26. The bushing retainer 22 has an aperture 28 in which the bushing 24 is placed. As will be described below, the bushing retainer 22 is removably attached to a brake spider 30.

The primary purpose for the bushing assembly 20 is to support the brake camshaft 32, shown in phantom. As known, a brake camshaft 32 drives a brake cam 31, shown schematically. This particular bushing assembly 20 is preferably used as the camshaft support closest to the wheel hub 33.

As shown in Figure 2, bushing assembly 20 has a longitudinal axis and transverse axis. The retainer aperture 28 preferably extends along the longitudinal axis. Further, the aperture 28 forms a retainer side wall 34 having an inner retainer surface 36 and an outer retainer surface 38. The bushing is preferably cylindrically shaped having an outer circumference surface 40 and an interior surface 42.

The retainer 22 preferably has four flanges 44 each having a hole 46. As shown in figure 3, preferably bolts 48 are received within the holes 46 for bolting the retainer 22 to the brake spider 30.

As best shown in Figure 4, the retainer 22 has a hole 50 that extends along the transverse axis through the retainer side wall 34 from the outer retainer surface 38 to the inner retainer surface 36 to the retainer aperture 28. The hole 50 allows for the flow of a lubricant into the aperture 28 to lubricate the camshaft 32. A grease fitting 26 is received within the retainer hole 50 to guide the lubricant into the retainer aperture 28.

The outer circumference 40 of the bushing 24 is adjacent the inner retainer surface 36 when the bushing 24 is disposed within the retainer 22. The bushing 24 has a groove 52 extending along its outer circumference 40 that is aligned with the retainer hole 50. The groove 52 receives the lubricant from the grease fitting 26 and further allows for the flow of the lubricant.

Attorney Docket No. 98 AUT 083

The bushing 24 also has at least one outlet hole 54 that is aligned with the circumferential groove 52. The outlet hole 54 extends along a transverse axis through the bushing wall 56 and allows for release of the lubricant from the circumferential groove 52 into the aperture 28. The outlet hole or holes 54 are preferably spaced apart from the retainer hole 50.

The bushing 24 also has at least one groove 58 and preferably two, on its interior surface 42 extending along the longitudinal axis to further facilitate the flow of the lubricant around the cam shaft 32. The groove or grooves 58 are preferably spaced by 90° from the outlet holes 54.

The bushing 24 is removably connected to the retainer 22. Preferably, it is pressed in the bushing retainer 22 creating an interference fit. The bushing 24 can be pressed out from the retainer 22, thus leaving the retainer 22 in place. This allows for reduced maintenance costs. The bushing 24 can be removed for maintenance, replacement, or for access to the camshaft. As mentioned above, since bushing 24 can be removed without removing retainer 22, the torque on the retainer bolts can be maintained.

In the prior art, when using non-removable retainers, the wheel hubs 33 needed to be removed to remove camshaft 32. Also, the retainers 22 will sometimes wear with non-removable retainers. This required replacement of the entire spider. For this reason, it is desirable to have both a removable bushing and a removable retainer. The present invention is the first to provide the combination.

Both the bushing retainer 22 and the bushing 24 are preferably formed from powdered metal. The bushing retainer 22 preferably consists of carbon steel, whereas, the bushing 24 preferably consists of a high copper content ferrous alloy.

Attorney Docket No. 98 AUT 083

The invention has been described in an illustrative manner, and it is to be understood that the terminology that has been used is intended to be in the nature of words of description rather than of limitation. Modifications and variations of the examples described above are possible and it must be understood that such changes may be within the scope of the following claims. In other words, the invention may be practiced otherwise than as specifically described above.

Attorney Docket No. 98 AUT 083

CLAIMS

What is claimed is:

1. A cam bushing assembly for a cam braking system comprising:
a removable bushing retainer having an aperture; and
a bushing having an interior bore for supporting a camshaft, said camshaft being disposed within said aperture, and said bushing is removably connected to said retainer.
2. The assembly of claim 1, wherein said bushing retainer and said bushing are made of metal.
3. The assembly of claim 2, wherein said bushing retainer and said bushing are made of powdered metal.
4. The assembly of claim 1, further comprising a brake spider, said brake spider being mounted to support a brake cam, and said bushing retainer being removably connected to said brake spider.
5. The assembly of claim 4, wherein said bushing retainer has at least one flange having a hole.
6. The assembly of claim 5, wherein said bushing retainer is bolted to said brake spider by at least one bolt received in said retainer flange hole.

Attorney Docket No. 98 AUT 083

7. The assembly of claim 6, wherein said bushing retainer has four flanges each having a hole, said retainer is bolted to said brake spider with four bolts, wherein each bolt is received within one of said four retainer flange holes.
8. The assembly of claim 7, wherein said retainer has a longitudinal axis and a transverse axis, said aperture extends along the longitudinal axis.
9. The assembly of claim 8, wherein said aperture in said retainer forms a side wall having an inner retainer surface and an outer retainer surface, said retainer having a hole extending along the transverse axis through said side wall from said outer retainer surface to said inner retainer surface into said aperture allowing for flow of a lubricant into said aperture.
10. The assembly of claim 9, further comprising a grease fitting received within said hole through said side wall of said retainer, said grease fitting further facilitates the flow of lubricant into said retainer aperture.

Attorney Docket No. 98 AUT 083

11. The assembly of claim 1, wherein said bushing is cylindrical in shape having an outer circumference and said interior bore, said bushing outer circumference is adjacent an inner retainer surface of said aperture when said bushing is disposed within said retainer;

said bushing having a groove extending around its outer circumference aligned with a hole through a side wall of said retainer when said bushing is disposed within said retainer, said groove further allows flow of the lubricant introduced through said hole, said bushing having at least one outlet hole extending through said bushing from said outer circumference to said interior bore, said outlet hole being aligned with said groove for release of the lubricant into said aperture.

12. The assembly of claim 11, wherein said at least one outlet hole in said bushing is spaced apart from said hole in said retainer.

13. The assembly of claim 12, wherein said bushing has at least one groove on said interior bore extending along a longitudinal axis allowing flow of the lubricant.

Attorney Docket No. 98 AUT 083

14. A cam assembly for a cam braking system comprising:

a brake spider for supporting and facilitating lubrication of a cam shaft portion of a cam brake;

a cam mounted adjacent said spider;

a bushing retainer having an aperture along a longitudinal axis, said retainer having at least one flange having a hole for receiving a bolt to bolt said retainer to said brake spider and allowing said retainer to be removably connected to said brake spider, said retainer having a hole facilitating the flow of a lubricant into said aperture; and

a bushing being generally cylindrical in shape having an outer circumference and an interior surface, said bushing being pressed into said retainer aperture creating an interference fit and is removably connected to said retainer.

15. An assembly as set forth in claim 14, wherein said bushing having a groove extending around said outer circumference, said groove aligned with said hole in said retainer for receiving lubricant introduced through said retainer hole.

16. An assembly as set forth in claim 15, wherein said bushing has at least one outlet hole extending through said bushing from said outer circumference to said interior surface along the transverse axis for release of the lubricant into said aperture, said at least one outlet hole being spaced apart from said retainer hole.

Attorney Docket No. 98 AUT 083

17. An assembly as set forth in claim 16, wherein said bushing having at least one groove along the longitudinal axis on said interior surface, said at least one groove further allows for the flow of the lubricant.

18. An assembly as set forth in claim 14, wherein said bushing and said retainer are formed of powdered metal.

19. An assembly as set forth in claim 14, wherein there are four of said flanges and said holes.

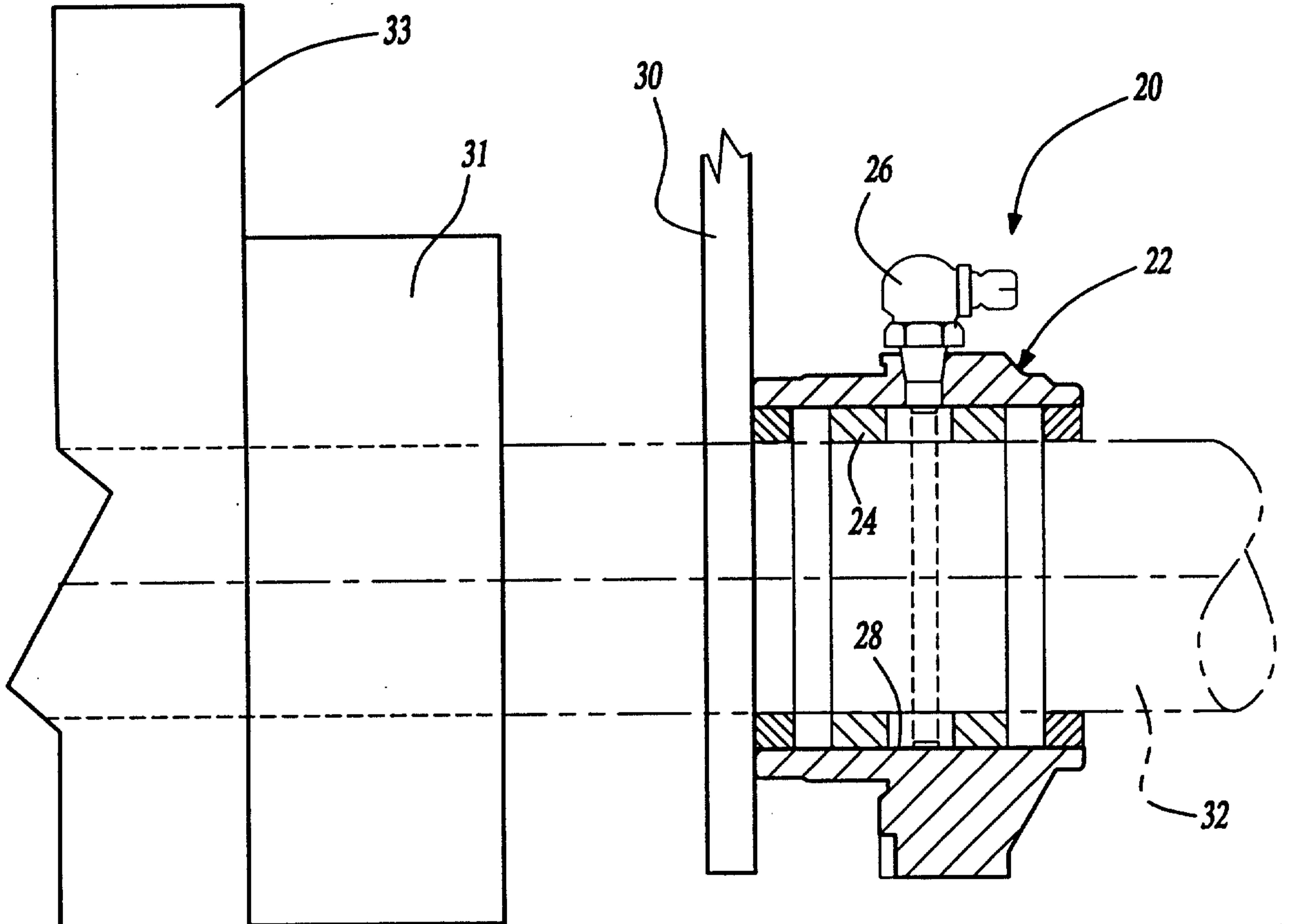

Fig-1

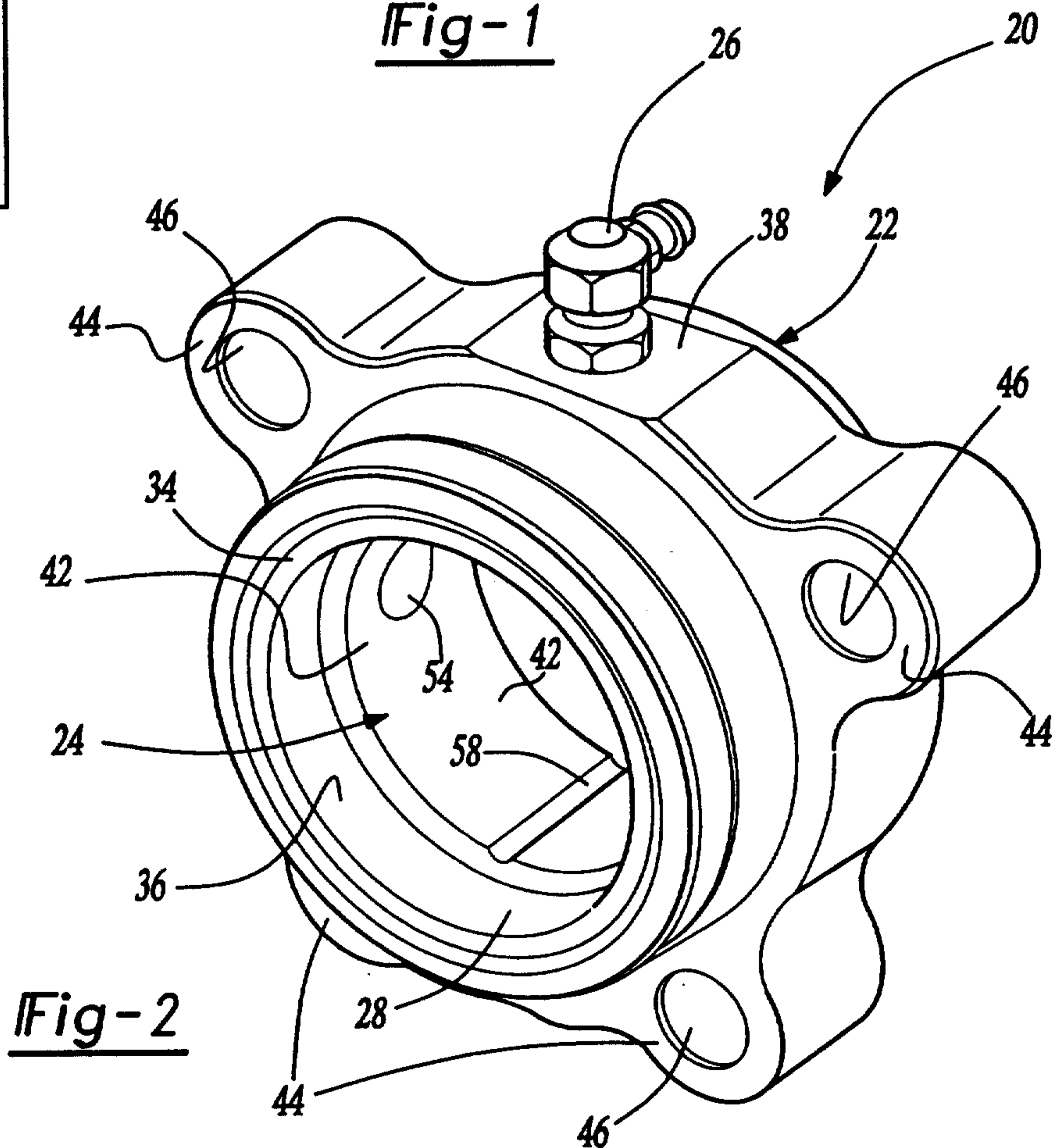

Fig-2

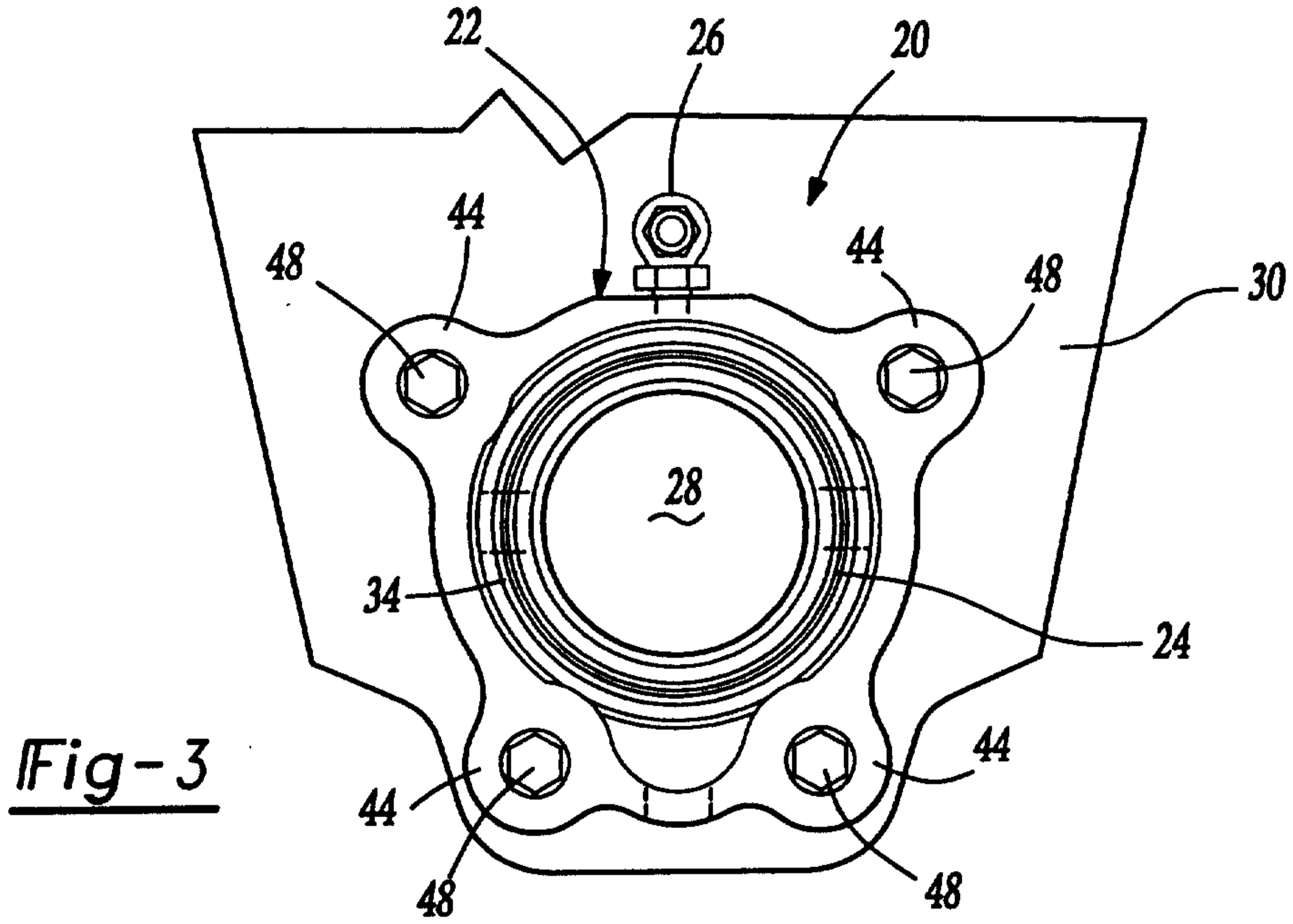

Fig-3

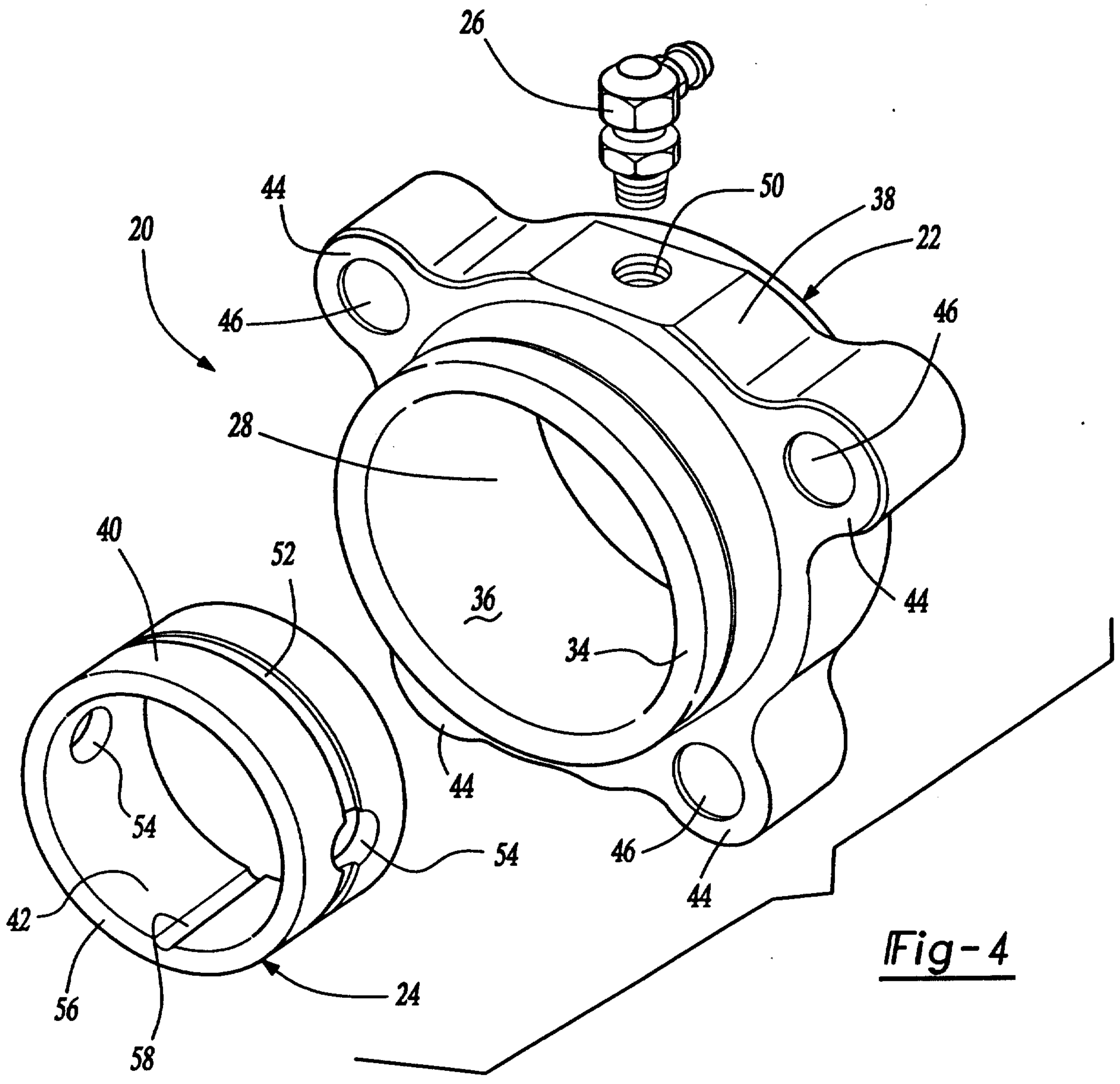

Fig-4

