

J. L. ANDERSON.

Railroad Switch-Locks.

No. 133,556.

Patented Dec. 3, 1872.

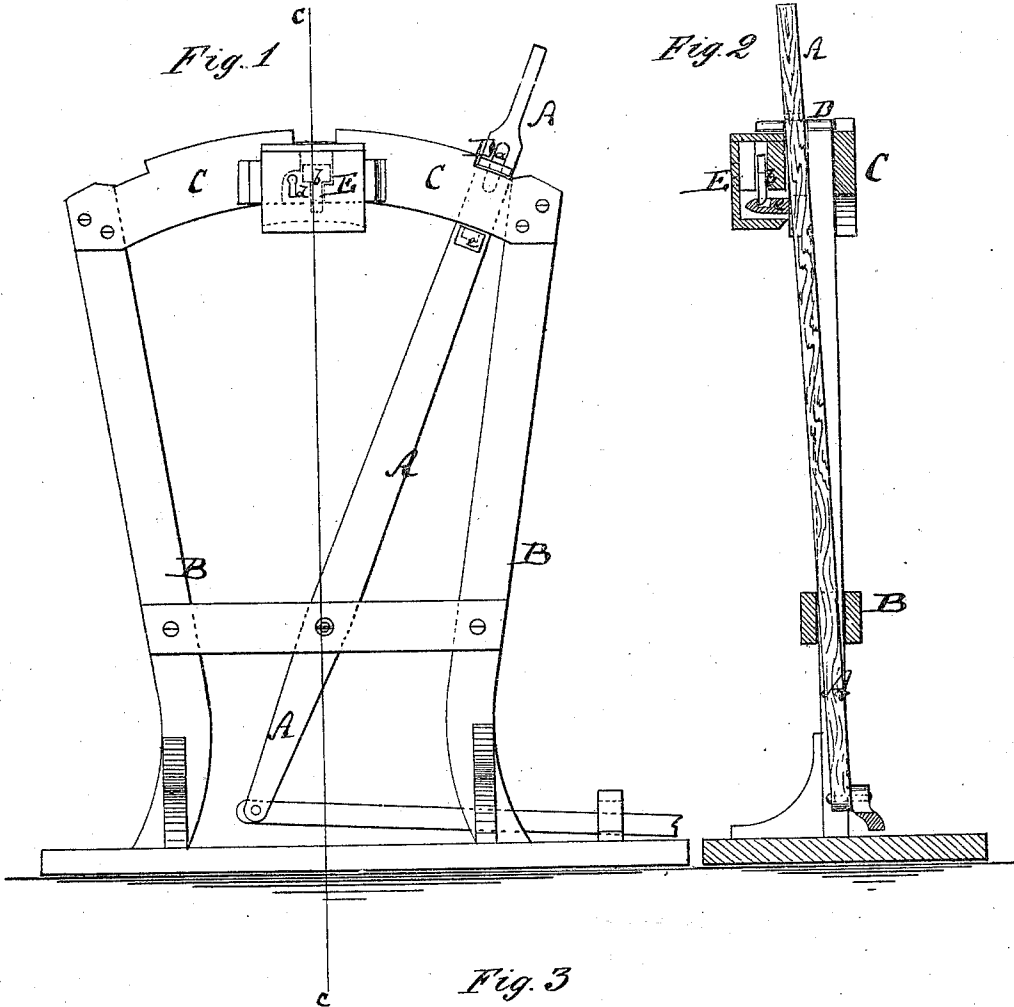

Witnesses:  
*A. W. Almquist*  
*Chiquiet*

Inventor:  
*J. L. Anderson*  
PER *Munn & Co.*  
Attorneys.

# UNITED STATES PATENT OFFICE.

JAMES L. ANDERSON, OF BUCYRUS, OHIO.

## IMPROVEMENT IN RAILROAD-SWITCH LOCKS.

Specification forming part of Letters Patent No. 133,556, dated December 3, 1872.

*To all whom it may concern:*

Be it known that I, JAMES L. ANDERSON, of Bucyrus, in the county of Crawford and State of Ohio, have invented a new and Improved Railroad-Switch Lock, of which the following is a specification:

Figure 1 is a face view of my improved railroad-switch lock. Fig. 2 is a vertical transverse section of the same on the line *c c*, Fig. 1. Fig. 3 is a top view of the upper bolt of the lock.

Similar letters of reference indicate corresponding parts.

This invention relates to a new means for locking the switch-levers on railroads automatically and effectively. The invention consists in providing the switch-lever with an up-and-down adjustable transverse bolt, which will drop into notches of the arcs between which the lever can be moved. The invention also consists in combining with the aforementioned key a projecting ear on the lever, a vertical drop-bolt for locking into it, and an ordinary key for raising the drop-bolt and liberating the lever when desired.

A in the drawing represents the switch-lever pivoted in a stationary frame, B, and guided between two arcs, C C, which are rigidly connected with the said frame B. D is a bolt fitted transversely through the lever A, and up and down adjustable in a slot, *a*, of said lever. The upper edges of the arcs C C are notched in the places in which the switch-lever may have to be locked. Whenever the lever in being moved arrives in line with a set of such notches

in the arcs the bolt D drops into the notches and locks the lever thus automatically to the arcs in the manner indicated in Fig. 1. E is a box or case fastened to the side of one arch, C, and containing a drop-bolt, *b*, and also a key-hole, *d*, for the admission of a key (not shown) for raising the drop-bolt. On the lever A is formed a projecting ear, *e*, as shown in Fig. 2. Whenever the lever A arrives in the middle of the space between the arches, or wherever else it holds the rails in the normal ordinary position, it arrives also in line with the box or case E, and is moved toward the box in the recess of the arc, so that its ear *e* enters the box under the bolt *b*. The latter bolt drops into a notch of the ear *e*, as shown in Fig. 2, and thus double locks the lever. By means of the key the bolt *b* can be raised off the ear *e* to release the lever and allow it to be moved, provided the bolt D is also raised out of the notch.

Having thus described my invention, I claim as new and desire to secure by Letters Patent—

1. The transverse bolt D, fitted through the vertical slot of the lever A to lock in the notched arcs C C, as set forth.
2. The combination of the lever A and bolt D with the ear *e* and drop-bolt *b*, all operating as specified.

JAMES LEWIS ANDERSON.

Witnesses:

J. C. HALL,  
S. R. HARRIS.