



(19) **United States**

(12) **Patent Application Publication**
Cauthen

(10) **Pub. No.: US 2003/0120345 A1**

(43) **Pub. Date: Jun. 26, 2003**

(54) **SPINAL DISC ANNULUS RECONSTRUCTION METHOD AND SPINAL DISC ANNULUS STENT**

No. 09/484,706, filed on Jan. 18, 2000, now abandoned.

(76) Inventor: **Joseph C. Cauthen**, Gainesville, FL (US)

(60) Provisional application No. 60/160,710, filed on Oct. 20, 1999.

Publication Classification

Correspondence Address:

SALIWANCHIK LLOYD & SALIWANCHIK
A PROFESSIONAL ASSOCIATION
2421 N.W. 41ST STREET
SUITE A-1
GAINESVILLE, FL 326066669

(51) **Int. Cl.⁷** **A61F 2/44**
(52) **U.S. Cl.** **623/17.16; 623/17.12**

(21) Appl. No.: **10/365,730**

(22) Filed: **Feb. 12, 2003**

(57) **ABSTRACT**

Related U.S. Application Data

A surgical method of repair and reconstruction of the spinal disc wall (annulus) after surgical invasion or pathologic rupture, incorporating suture closure, or stent insertion and fixation, designed to reduce the failure rate of conventional surgical procedures on the spinal discs.

(63) Continuation of application No. 09/947,078, filed on Sep. 5, 2001, which is a continuation of application

The design of the spinal disc annulus stent allows ingrowth of normal cells of healing in an enhanced fashion strengthening the normal reparative process.

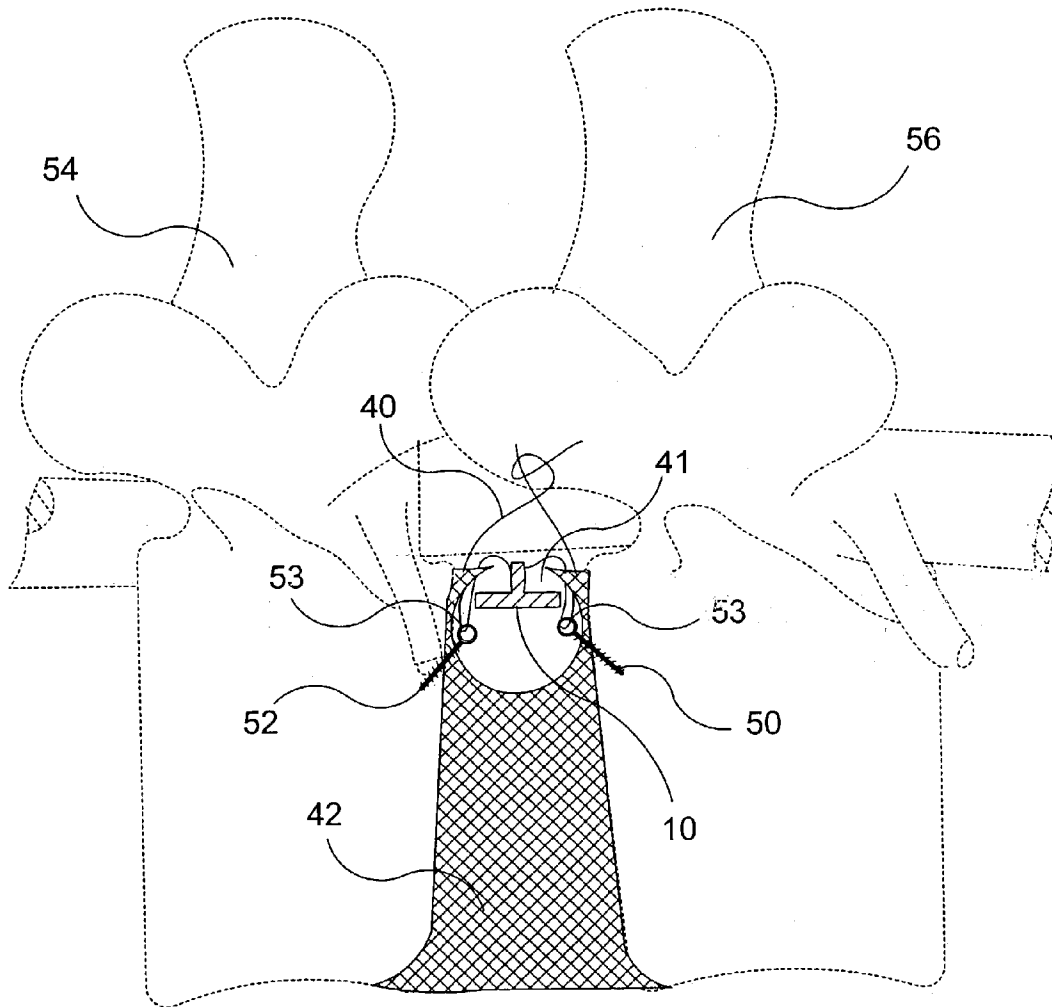

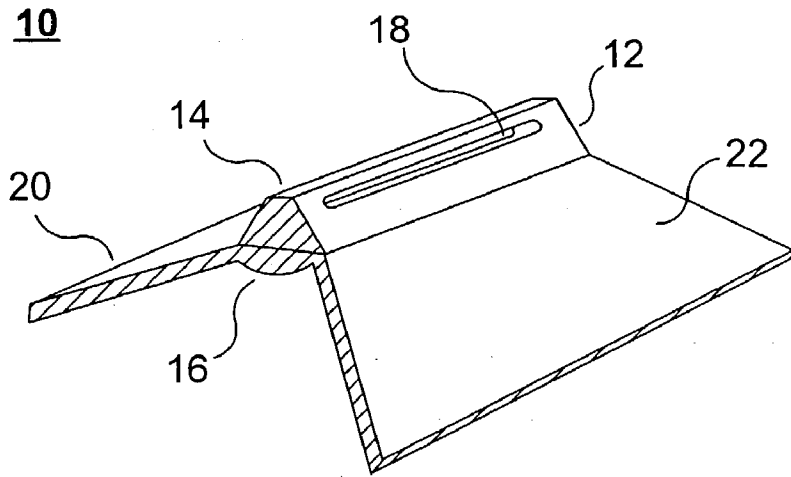

FIG. 1

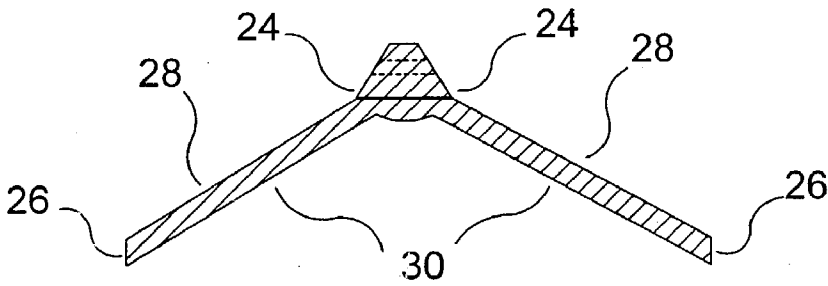

FIG. 2

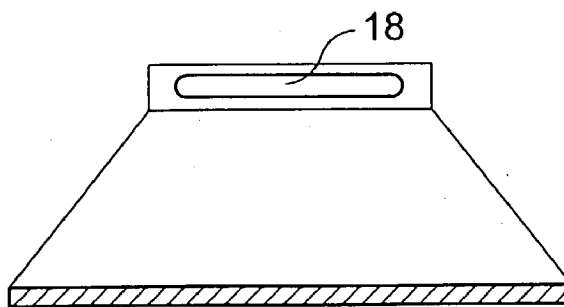

FIG. 3

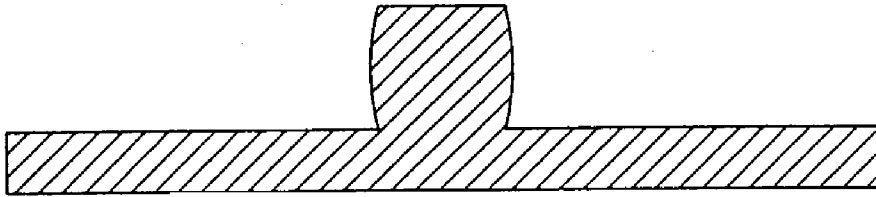

FIG. 4A

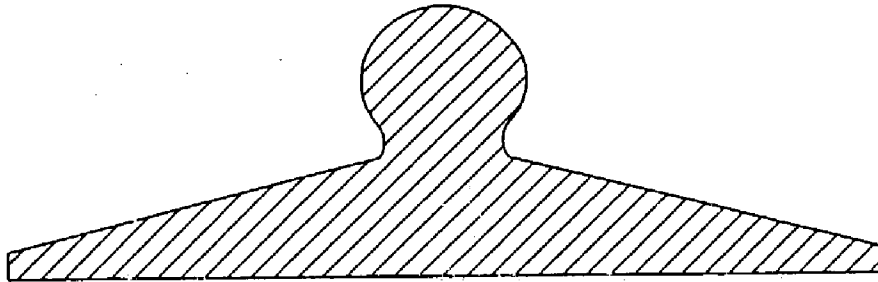

FIG. 4B

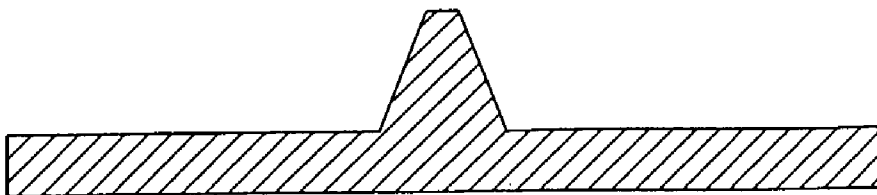

FIG. 4C

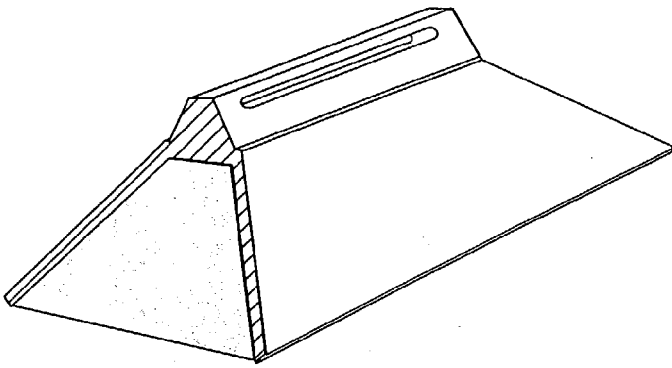

FIG. 5A

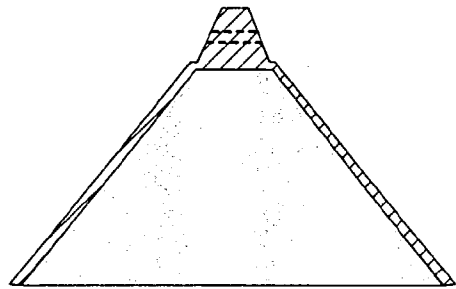

FIG. 5B

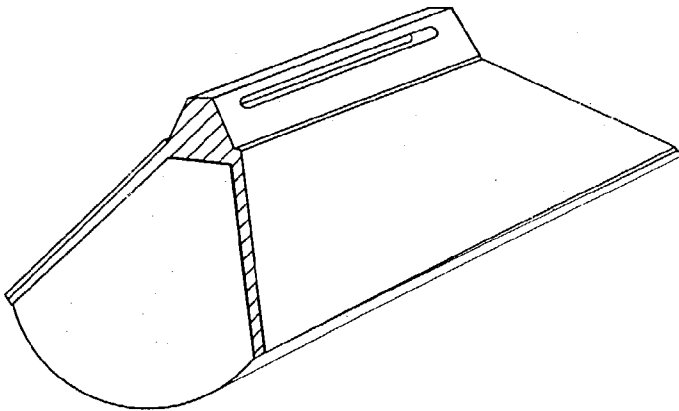

FIG. 6A

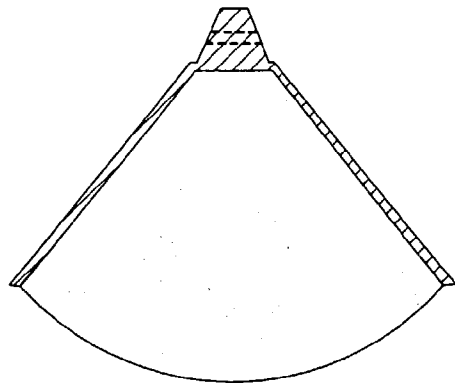

FIG. 6B

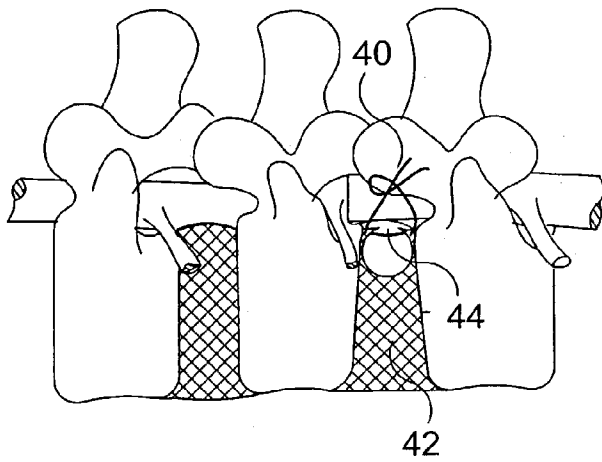

FIG. 7A

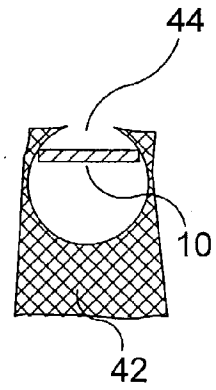

FIG. 7B

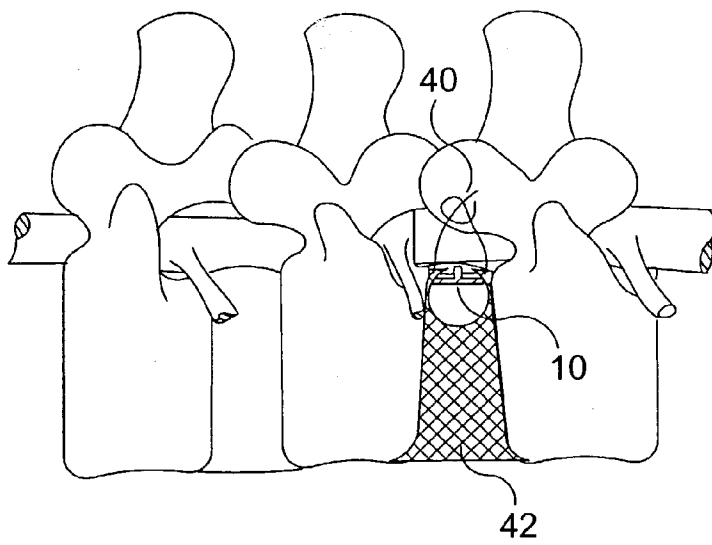

FIG. 8A

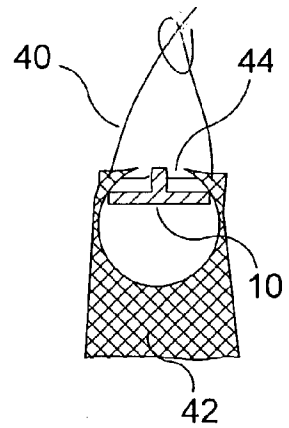

FIG. 8B

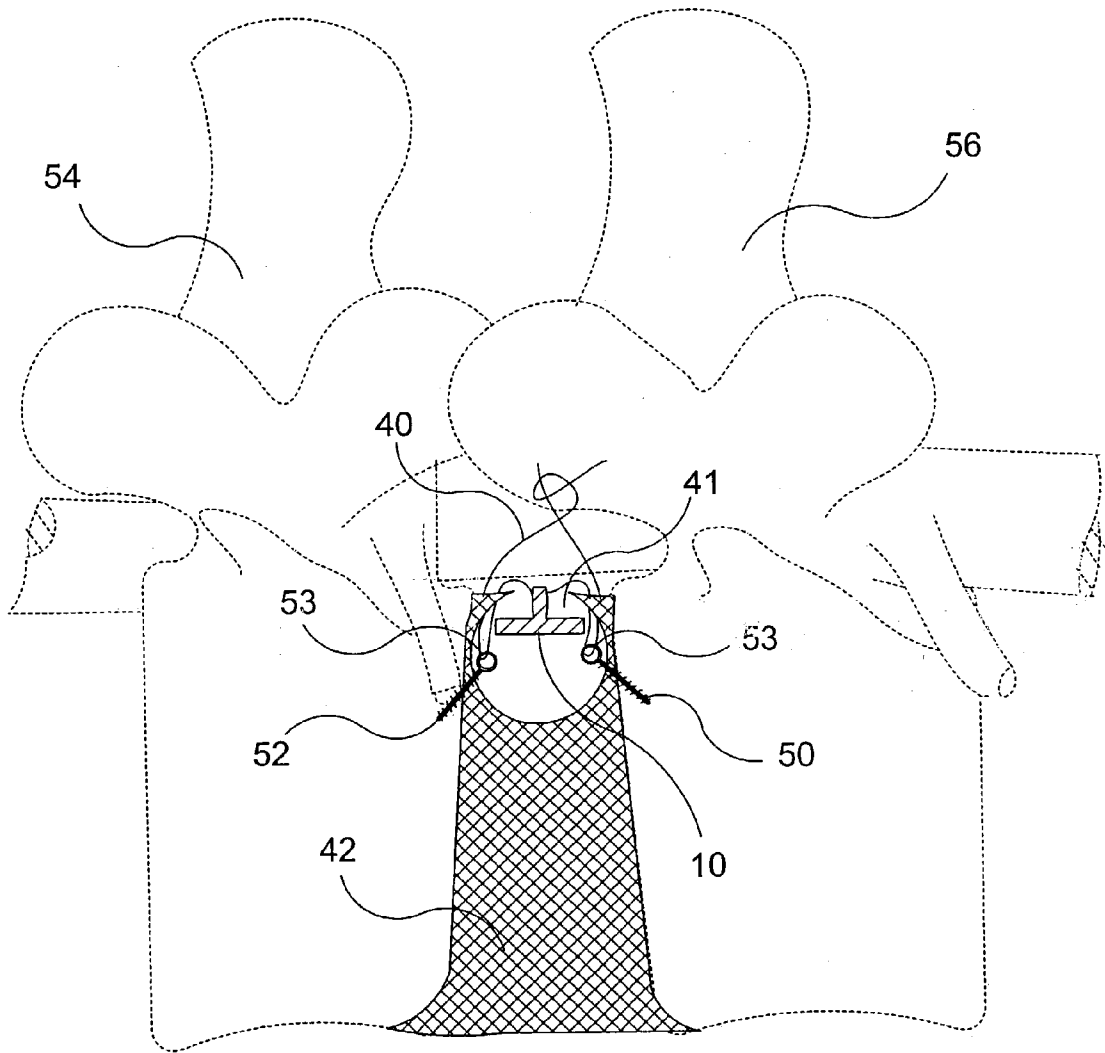

FIG. 9

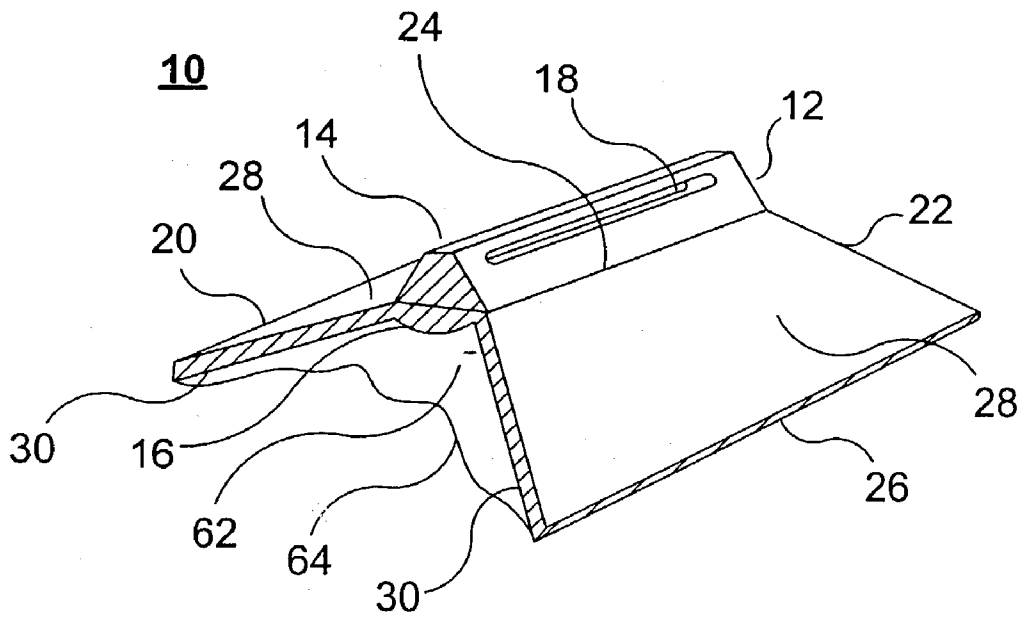

FIG. 10A

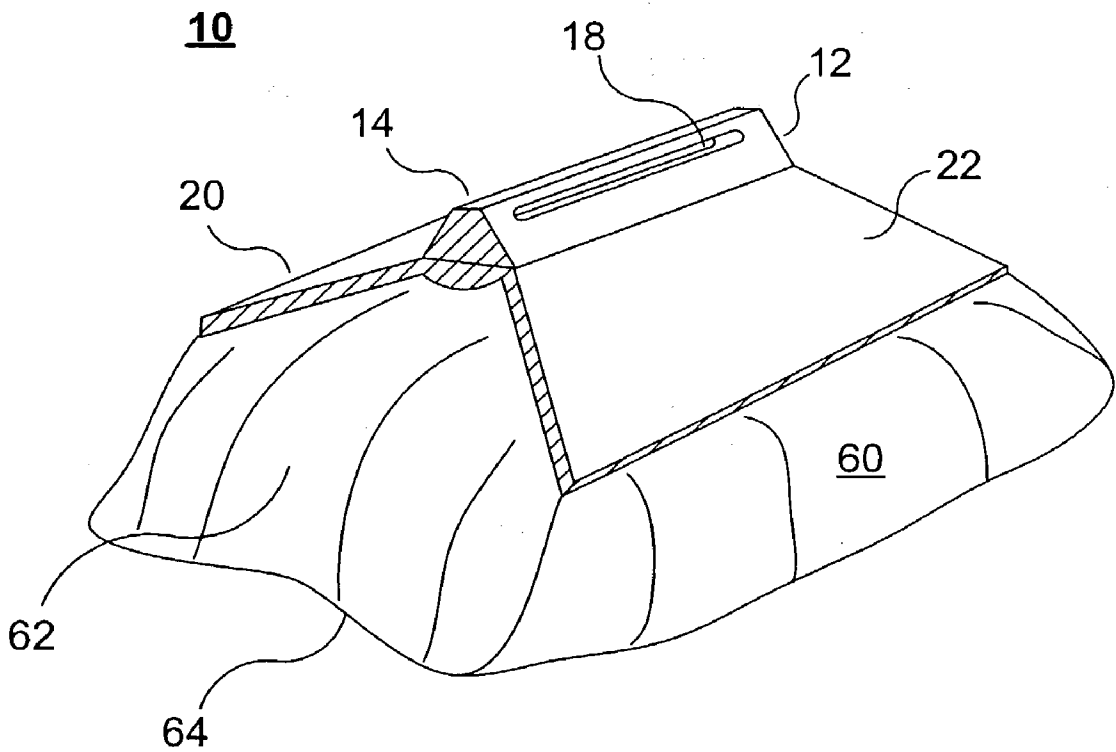

FIG. 10B

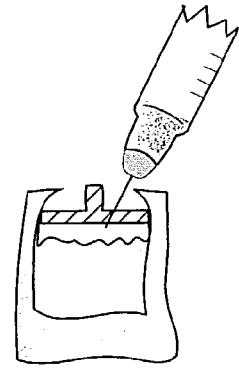
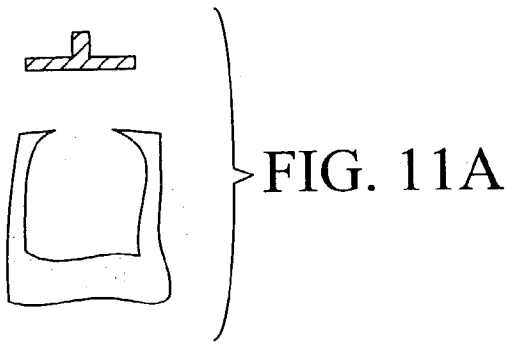

FIG. 12A

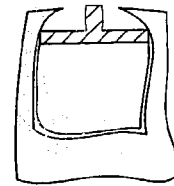
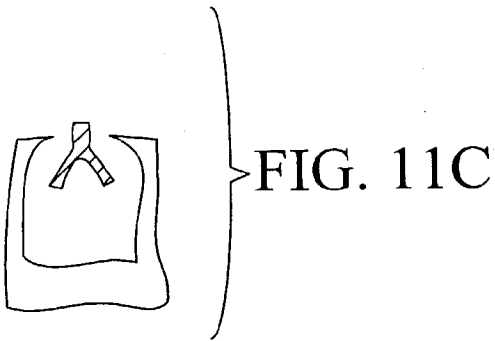
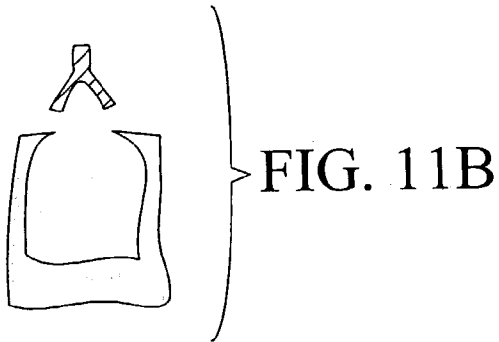
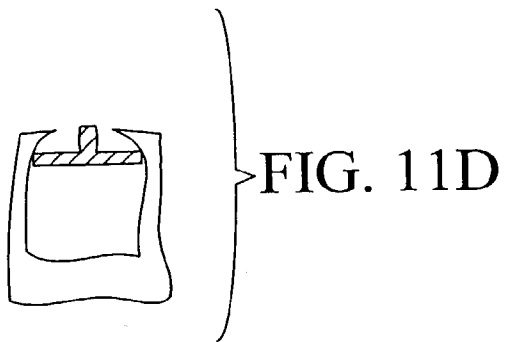

FIG. 12B



SPINAL DISC ANNULUS RECONSTRUCTION METHOD AND SPINAL DISC ANNULUS STENT

CROSS-REFERENCE TO A RELATED APPLICATION

[0001] This application is a continuation of co-pending U.S. Ser. No. 09/947,078, filed Sep. 5, 2001; which is a continuation of U. S. Ser. No. 09/484,706, filed Jan. 18, 2000 (now abandoned); which claims the benefit of U.S. Provisional Application No. 60/160,710, filed Oct. 20, 1999.

FIELD OF THE INVENTION

[0002] The invention generally relates to a surgical method of intervertebral disc wall reconstruction with a related annulus stent augmenting the repair. The effects of said reconstruction are restoration of disc wall integrity and reduction of the failure rate (3-21%) of a common surgical procedure (disc fragment removal or discectomy). This surgical procedure is performed about 390,000 times annually in the United States.

BACKGROUND OF THE INVENTION

[0003] The spinal column is formed from a number of vertebrae, which in their normal state are separated from each other by cartilaginous intervertebral discs. The intervertebral disc acts in the spine as a crucial stabilizer, and as a mechanism for force distribution between the vertebral bodies. Without the disc, collapse of the intervertebral space occurs in conjunction with abnormal joint mechanics and premature development of arthritic changes.

[0004] The normal intervertebral disc has an outer ligamentous ring called the annulus surrounding the nucleus pulposus. The annulus binds the adjacent vertebrae together and is constituted of collagen fibers that are attached to the vertebrae and cross each other so that half of the individual fibers will tighten as the vertebrae are rotated in either direction, thus resisting twisting or torsional motion. The nucleus pulposus is constituted of loose tissue, having about 85% water content, which moves about during bending from front to back and from side to side.

[0005] As people age, the annulus tends to thicken, desiccate, and become more rigid. The nucleus pulposus, in turn, becomes more viscous and less fluid and sometimes even dehydrates and contracts. The annulus also becomes susceptible to fracturing or fissuring. These fractures tend to occur all around the circumference of the annulus and can extend from both the outside of the annulus inwards, and the interior outward. Occasionally, a fissure from the outside of the annulus meets a fissure from the inside and results in a complete rent or tear through the annulus fibrosis. In situations like these, the nucleus pulposus may extrude out through the annulus wall. The extruded material, in turn, can impinge on the spinal cord or on the spinal nerve rootlet as it exits through the intervertebral disc foramen, resulting in a condition termed ruptured disc or herniated disc

[0006] In the event of annulus rupture, the inner-nucleus component migrates along the path of least resistance forcing the fissure to open further, allowing migration of the nucleus pulposus through the wall of the disc, with resultant nerve compression and leakage of chemicals of inflammation into the space around the adjacent nerve roots supplying

the extremities, bladder, bowel and genitalia. The usual effect of nerve compression and inflammation is intolerable back or neck pain, radiating into the extremities, with accompanying numbness, weakness, and in late stages, paralysis and muscle atrophy, and/or bladder and bowel incontinence. Additionally, injury, disease or other degenerative disorders may cause one or more of the intervertebral discs to shrink, collapse, deteriorate or become displaced, herniated, or otherwise damaged.

[0007] The surgical standard of care for treatment of herniated, displaced or ruptured intervertebral discs is fragment removal and nerve decompression without a requirement to reconstruct the annular wall. While results are currently acceptable, they are not optimal. Various authors report 3.1-21% recurrent disc herniation, representing a failure of the primary procedure and requiring re-operation for the same condition. An estimated 10% recurrence rate results in 39,000 re-operations in the United States each year.

[0008] An additional method of relieving the symptoms is thermal annuloplasty, involving the heating of sub-annular zones in the non-herniated painful disc, seeking pain relief, but making no claim of reconstruction of the ruptured, discontinuous annulus wall.

[0009] There is currently no known method of annulus reconstruction, either primarily or augmented with an annulus stent.

BRIEF SUMMARY OF THE INVENTION

[0010] The present invention provides methods and related materials for reconstruction of the disk wall in cases of displaced, herniated, ruptured, or otherwise damaged intervertebral discs.

[0011] In a preferred form, one or more mild biodegradable surgical sutures are placed at about equal distances along the sides of a pathologic aperture in the ruptured disc wall (annulus) or along the sides of a surgical incision in the weakened, thinned disc annulus.

[0012] Sutures are then tied in such fashion as to draw together the sides of the aperture, effecting reapproximation or closure of the opening, to enhance natural healing and subsequent reconstruction by natural tissue (fibroblasts) crossing the now surgically narrowed gap in the disc annulus.

[0013] A 25-30% reduction in the rate of recurrence of disc nucleus herniation through this aperture, has been achieved using this method.

[0014] In another embodiment, the method can be augmented by placement of a patch of human muscle fascia (the membrane covering the muscle) or any other autograft or allograft acting as a bridge in and across the aperture, providing a platform for traverse of fibroblasts or other normal cells of repair existing in and around the various layers of the disc annulus, prior to closure of the aperture.

[0015] A 30-50% reduction in the rate of recurrence of disc herniation has been achieved using the aforementioned fascial augmentation with this embodiment.

[0016] Having demonstrated that human muscle fascia is adaptable for annular reconstruction, other biocompatible

membranes can be employed as a bridge, stent, patch or barrier to subsequent migration of the disc nucleus through the aperture. Such biocompatible materials may be, for example, a medical grade biocompatible fabric, biodegradable polymeric sheets, or form fitting or non-form fitting fillers for the cavity created by removal of a portion of the disc nucleus in the course of the disc fragment removal or discectomy. The prosthetic material can be placed in and around the intervertebral space, created by removal of the degenerated disc fragments.

BRIEF DESCRIPTION OF THE DRAWINGS

[0017] FIG. 1 shows a perspective view of the annulus stent.

[0018] FIG. 2 shows a front view of the annulus stent.

[0019] FIG. 3 shows a side view of the annulus stent.

[0020] FIGS. 4A-4C show a front view of various alternative embodiments of the annulus stent.

[0021] FIGS. 5A-5B shows the alternative embodiment of a pyramid shaped annulus stent.

[0022] FIGS. 6A-6B shows the alternative embodiment of a coned shaped annulus stent.

[0023] FIG. 7 shows the primary closure of the opening in the disc annulus, without an intervertebral or subannular stent.

[0024] FIGS. 8A-8B shows the primary closure with a stent in generic form.

[0025] FIG. 9 shows a method of suturing the annulus stent into the disc annulus, utilizing sub-annular fixation points.

[0026] FIGS. 10A-10B show the annulus stent with flexible bladder being expanded into the disc annulus.

[0027] FIGS. 11A-11D show the annulus stent being inserted into the disc annulus.

[0028] FIGS. 12A-12B show the annulus stent with the flexible bladder being expanded by injection.

DETAILED DESCRIPTION OF THE INVENTION

[0029] The present invention provides methods and related materials for reconstruction of the disk wall in cases of displaced, herniated, ruptured, or otherwise damaged intervertebral discs.

[0030] In one embodiment of the present invention, as shown in FIG. 7, a damaged annulus 42 is repaired by use of surgical sutures 40. One or more surgical sutures 40 are placed at about equal distances along the sides of a pathologic aperture 44 in the ruptured annulus 42. Reapproximation or closure of the aperture 44 is accomplished by tying the sutures 40 in such a fashion that the sides of the aperture 44 are drawn together. The reapproximation or closure of the aperture 44 enhances the natural healing and subsequent reconstruction by the natural tissue crossing the now surgically narrowed gap in the annulus 42. Preferably, the surgical sutures 40 are biodegradable, but permanent non-biodegradable may be utilized.

[0031] Additionally, to repair a weakened or thinned disc annulus 42, a surgical incision is made along the weakened or thinned region of the annulus 42 and one or more surgical sutures 40 are placed at about equal distances along the sides of the incision. Reapproximation or closure of the incision is accomplished by tying the sutures 40 in such a fashion that the sides of the incision are drawn together. The reapproximation or closure of the incision enhances the natural healing and subsequent reconstruction by the natural tissue crossing the now surgically narrowed gap in the annulus 42. Preferably, the surgical sutures 40 are biodegradable, but permanent non-biodegradable materials may be utilized.

[0032] In an alternative embodiment, the method can be augmented by the placement of a patch of human muscle fascia or any other autograft, allograft or xenograft in and across the aperture 44. The patch acts as a bridge in and across the aperture, providing a platform for traverse of fibroblasts or other normal cells of repair existing in and around the various layers of the disc annulus, prior to closure of the aperture.

[0033] In a further embodiment, as shown in FIG. 8, a biocompatible membrane can be employed as an annulus stent 10, being placed in and across the aperture 44. The annulus stent 10 acts as a bridge in and across the aperture 44, providing a platform for a traverse of fibroblasts or other normal cells of repair existing in and around the various layers of the disc annulus, prior to closure of the aperture 44.

[0034] In a preferred embodiment, as shown in FIGS. 1-3, the annulus stent 10 comprises a centralized vertical extension 12, with an upper section 14 and a lower section 16. The centralized vertical extension 12 can be trapezoid in shape through the width and may be from about 8 mm-12 mm in length.

[0035] Additionally, the upper section 14 of the centralized vertical extension 12 may be any number of different shapes, as shown in FIGS. 4A and 4B, with the sides of the upper section 14 being curved or with the upper section 14 being circular in shape. Furthermore, the annulus stent 10 may contain a recess between the upper section 14 and the lower section 16, enabling the annulus stent 10 to form a compatible fit with the edges of the aperture 44.

[0036] The upper section 14 of the centralized vertical extension 12 can comprise a slot 18, where the slot 18 forms an orifice through the upper section 14. The slot 18 is positioned within the upper section such that 14 it traverses the upper section's 14 longitudinal axis. The slot 18 is of such a size and shape that sutures, tension bands, staples or any other type of fixation device known in the art may be passed through, to affix the annulus stent 10 to the disc annulus 44.

[0037] In an alternative embodiment, the upper section 14 of the centralized vertical extension 12 may be perforated. The perforated upper section 14 contains a plurality of holes which traverse the upper section's 14 longitudinal axis. The perforations are of such a size and shape that sutures, tension bands, staples or any other type of fixation device known in the art may be passed through, to affix the annulus stent 10 to the disc annulus 44.

[0038] The lower section 16 can comprise a pair of lateral extensions, a left lateral extension 20 and a right lateral extension 22. The lateral extensions 20 and 22 comprise an

inside edge 24, an outside edge 26, an upper surface 28, and a lower surface 30. The lateral extensions 20 and 22 can have an essentially constant thickness throughout. The inside edge 24 is attached to the lower section 16 and is about the same length as the lower section 16. The outside edge 26 can be about 8 mm-16 mm in length. The inside edge 24 and the lower section 16 meet to form a horizontal plane, essentially perpendicular to the centralized vertical extension 12. The upper surface 28 of the lateral extensions 20 and 22 can form an angle of about 0°-60° below the horizontal plane. The width of the annulus stent 10 may be from about 3 mm-5 mm.

[0039] Additionally, the upper surface 28 of the lateral extensions 20 and 22 may be barbed for fixation to the inside surface of the disc annulus 40 and to resist expulsion through the aperture 44.

[0040] In an alternative embodiment, as shown in FIG. 4B, the lateral extensions 20 and 22 have a greater thickness at the inside edge 24 than at the outside edge 26.

[0041] In a preferred embodiment, the annulus stent 10 is a solid unit, formed from one or more of the flexible resilient biocompatible or bioresorbable materials well known in the art.

[0042] For example, the annulus stent may be made from:

[0043] a porous matrix or mesh of biocompatible and bioresorbable fibers acting as a scaffold to regenerate disc tissue and replace annulus fibrosus as disclosed in, for example, U.S. Pat. No. 5,108,438 (Stone) and U.S. Pat. No. 5,258,043 (Stone);

[0044] a strong network of inert fibers intermingled with a bioresorbable (or biosorbable) material which attracts tissue ingrowth as disclosed in, for example, U.S. Pat. No. 4,904,260 (Ray et al.);

[0045] a biodegradable substrate as disclosed in, for example, U.S. Pat. No. 5,964,807 (Gan et al.); or

[0046] an expandable polytetrafluoroethylene (ePTFE), as used for conventional vascular grafts, such as those sold by W.L. Gore and Associates, Inc. under the trademarks GORE-TEX and PRECLUDE, or by Impra, Inc. under the trademark IMPRA.

[0047] Furthermore, the annulus stent 10, may contain hygroscopic material for a controlled limited expansion of the annulus stent 10 to fill the evacuated disc space cavity.

[0048] Additionally, the annulus stent 10 may comprise materials to facilitate regeneration of disc tissue, such as bioactive silica-based materials which assist in regeneration of disc tissue as disclosed in U.S. Pat. No. 5,849,331 (Ducheyne, et al.), or other tissue growth factors well known in the art.

[0049] In further embodiments, as shown in FIGS. 5-6, the left and right lateral extensions 20 and 22 join to form a solid pyramid or cone. Additionally, the left and right lateral extensions 20 and 22 may form a solid trapezoid, wedge, or bullet shape. The solid formation may be a solid biocompatible or bioresorbable flexible material, allowing the lateral extensions 20 and 22 to be compressed for insertion into aperture 44, then to expand conforming to the shape of the annulus' 42 inner wall.

[0050] Alternatively, a compressible core may be attached to the lower surface 30 of the lateral extensions 20 and 22, forming a pyramid, cone, trapezoid, wedge, or bullet shape. The compressible core may be made from one of the biocompatible or bioresorbable resilient foams well known in the art. The compressible core allows the lateral extensions 20 and 22 to be compressed for insertion into aperture 44, then to expand conforming to the shape of the annulus' 42 inner wall and to the cavity created by pathologic extrusion or surgical removal of the disc fragment.

[0051] In a preferred method of use, as shown in FIGS. 10A-10D, the lateral extensions 20 and 22 are compressed together for insertion into the aperture 44 of the disc annulus 40. The annulus stent 10 is then inserted into the aperture 44, where the lateral extensions 20 and 22 expand, with the upper surface 28 contouring to the inside surface of the disc annulus 40. The upper section 14 is positioned within the aperture 44 so that the annulus stent 10 may be secured to the disc annulus 40, using means well known in the art.

[0052] In an alternative method, where the length of the aperture 44 is less than the length of the outside edge 26 of the annulus stent 10, the annulus stent 10 must be inserted laterally into the aperture 44. The lateral extensions 20 and 22 are compressed, and the annulus stent 10 is laterally inserted into the aperture 44. The annulus stent 10 is then rotated inside the disc annulus 40, such that the upper section 14 is pulled back through the aperture 44. The lateral extensions 20 and 22 are then allowed to expand, with the upper surface 28 contouring to the inside surface of the disc annulus 40. The upper section 14 is positioned within the aperture 44 such that the annulus stent 10 may be secured to the disc annulus, using means well known in the art.

[0053] In an alternative method of securing the annulus stent 10 in the aperture 44, as shown in FIG. 9, a first surgical screw 50 and second surgical screw 52, with eye holes 53 located at the top of the screws 50 and 52, are opposingly inserted into the adjacent vertebrae 54 and 56 below the annulus stent 10. After insertion of the annulus stent 10 into the aperture 44, a suture is passed down through the disc annulus 40, adjacent to the aperture 44, through the eye hole 53 on the first screw 50 then back up through the disc annulus 40 and through the orifice 18 on the annulus stent 10. This is repeated for the second screw 52, after which the suture is secured. One or more surgical sutures 40 are placed at about equal distances along the sides of the aperture 44 in the disc annulus 42. Reapproximation or closure of the aperture 44 is accomplished by tying the sutures 40 in such a fashion that the sides of the aperture 44 are drawn together. The reapproximation or closure of the aperture 44 enhances the natural healing and subsequent reconstruction by the natural tissue crossing the now surgically narrowed gap in the annulus 42. Preferably, the surgical sutures 40 are biodegradable but permanent nonbiodegradable forms may be utilized. This method should decrease the strain on the disc annulus 40 adjacent to the aperture 44, precluding the tearing of the sutures through the disc annulus 40.

[0054] It is anticipated that fibroblasts will engage the fibers of the polymer or fabric of the intervertebral disc stent, forming a strong wall duplicating the currently existing condition of healing seen in the normal reparative process.

[0055] In an additional embodiment, as shown in FIGS. 10A-B, a flexible bladder 60 is attached to the lower surface

30 of the annulus stent **10**. The flexible bladder **60** comprises an internal cavity **62** surrounded by a membrane **64**, where the membrane **64** is made from a thin flexible biocompatible material. The flexible bladder **60** is attached to the lower surface **28** of the annulus stent **10** in an unexpanded condition. The flexible bladder **60** is expanded by injecting a biocompatible fluid or expansive foam, as known in the art, into the internal cavity **62**. The exact size of the flexible bladder **60** can be varied for different individuals. The typical size of an adult nucleus is 2 cm in the semi-minor axis, 4 cm in the semi-major axis and 1.2 cm in thickness.

[**0056**] In an alternative embodiment, the membrane **64** is made of a semipermeable biocompatible material.

[**0057**] In a preferred embodiment, a hydrogel is injected into the internal cavity of the flexible bladder **28**. A hydrogel is a substance formed when an organic polymer (natural or synthetic) is cross-linked via covalent, ionic, or hydrogen bonds to create a three-dimensional open-lattice structure which entraps water molecules to form a gel. The hydrogel may be used in either the hydrated or dehydrated form.

[**0058**] In a method of use, where the annulus stent **10** has been inserted into the aperture, as has been previously described and shown in FIGS. **12 A-b**, an injection instrument, as known in the art, such as a syringe, is used to inject the biocompatible fluid or expansive foam into the internal cavity **62** of the flexible bladder **60**. The biocompatible fluid or expansive foam is injected through the annulus stent **10** into the internal cavity of the flexible bladder **28**. Sufficient material is injected into the internal cavity **62** to expand the flexible bladder **60** to fill the void in the intervertebral disc cavity. The use of the flexible bladder **60** is particularly useful when it is required to remove all or part of the intervertebral disc nucleus.

[**0059**] The surgical repair of an intervertebral disc may require the removal of the entire disc nucleus, being replaced with an implant, or the removal of a portion of the disc nucleus thereby leaving a void in the intervertebral disc cavity. The flexible bladder **60** allows for the removal of only the damaged section of the disc nucleus, with the expanded flexible bladder **60** filling the resultant void in the intervertebral disc cavity. A major advantage of the annulus stent **10** with the flexible bladder **60** is that the incision area in the annulus can be reduced in size as there is no need for the insertion of an implant into the intervertebral disc cavity.

[**0060**] In an alternative method of use, a dehydrated hydrogel is injected into the internal cavity **28** of the flexible bladder **60**. Fluid, from the disc nucleus, passes through the semi-permeable membrane **64** hydrating the dehydrated hydrogel. As the hydrogel absorbs the fluid the flexible bladder expands **60**, filling the void in the intervertebral disc cavity.

[**0061**] All patents referred to or cited herein are incorporated by reference in their entirety to the extent they are not inconsistent with the explicit teachings of this specification, including; U.S. Pat. No. 5,108,438 (Stone), U.S. Pat. No. 5,258,043 (Stone), U.S. Pat. No. 4,904,260 (Ray et al.), U.S. Pat. No. 5,964,807 (Gan et al.), U.S. Pat. No. 5,849,331 (Ducheyne et al.), U.S. Pat. No. 5,122,154 (Rhodes), U.S. Pat. No. 5,204,106 (Schepers et al.), U.S. Pat. No. 5,888,220 (Felt et al.) and U.S. Pat. No. 5,376,120 (Sarver et al.).

[**0062**] It should be understood that the examples and embodiments described herein are for illustrative purposes

only and that various modifications or changes in light thereof will be suggested to persons skilled in the art and are to be included within the spirit and preview of this application and the scope of the appended claims.

1. An annulus stent, for repair of an intervertebral disc annulus, comprising an elongated centralized vertical extension, said centralized vertical extension comprising a left and a right lateral extension along said centralized vertical extension's horizontal axis.

2. The annulus stent according to claim 1, wherein said vertical extension further comprises a slot.

3. The annulus stent according to claim 1, wherein said vertical extension is perforated.

4. The annulus stent according to claim 1, wherein said left and right lateral extensions comprise an inside edge, an outside edge, an upper surface and a lower surface, wherein said inside edge joins said centralized vertical extension to form a horizontal plane.

5. The annulus stent according to claim 4, wherein said upper surface forms an angle of about 0 to 60 degrees below said horizontal plane.

6. The annulus stent according to claim 4, wherein the length of said inside edge is less than the length of said outside edge.

7. The annulus stent according to claim 4, wherein said inside edge has a greater thickness than said outside edge.

8. The annulus stent according to claim 4, wherein said upper surface is barbed.

9. The annulus stent according to claim 4, further comprising a recess wherein said upper surface joins said centralized vertical extension.

10. The annulus stent according to claim 4, wherein said lateral extension further comprises a compressible core affixed to said lower surface.

11. The annulus stent according to claim 10, wherein said compressible core is made of a compressible biocompatible material.

12. The annulus stent according to claim 10, wherein said compressible core is made of a compressible bioreabsorbable material.

13. The annulus stent according to claim 4, further comprising a flexible bladder affixed to said lower surface of said left and right lateral extensions.

14. The annulus stent according to claim 13, wherein said flexible bladder comprises a membrane enclosing an internal cavity.

15. The annulus stent according to claim 14, wherein said internal cavity is empty.

16. The annulus stent according to claim 14, wherein said membrane comprises a thin flexible biocompatible material.

17. The annulus stent according to claim 16, wherein said membrane further comprises a semi-permeable material.

18. The annulus stent according to claim 17, wherein said internal cavity contains a biocompatible fluid.

19. The annulus stent according to claim 18, wherein said biocompatible fluid is a hydrogel.

20. The annulus stent according to claim 16, wherein said membrane further comprises an impermeable material.

21. The annulus stent according to claim 20, wherein said internal cavity contains a biocompatible fluid.

22. The annulus stent according to claim 1, wherein said centralized vertical extension is of a shape selected from the group consisting of a trapezoid, circular and curved.

23. The annulus stent according to claim 1, wherein said annulus stent is made from a material selected from the group consisting of a biocompatible material, a bioactive material, and a bioreabsorbable material.

24. The annulus stent according to claim 23, wherein said annulus stent is made from a biocompatible fiber mesh.

25. The annulus stent according to claim 23, wherein said annulus stent is made from a bioreabsorbable fiber mesh.

26. The annulus stent according to claim 23, wherein said annulus stent is made from expandable polytetra fluoroethylene.

27. The annulus stent according to claim 1, wherein said annulus stent comprises a material to facilitate regeneration of disc tissue.

28. The annulus stent according to claim 1, wherein said annulus stent comprises a hygroscopic material.

29. An annulus patch, wherein said annulus patch is of the size and shape for repair of a intervertebral disc annulus.

30. The annulus patch according to claim 29, wherein said annulus patch is human muscle fascia, an autograft, an allograft or a xenograft.

31. A method for repairing an intervertebral disc, wherein said intervertebral disc comprises a disc nucleus and a disc annulus, comprising the steps of;

- a) forming an aperture in said intervertebral disc annulus; and
- b) securing across said aperture to said intervertebral disc annulus an annulus patch.

32. The method for repairing an intervertebral disc according to claim 31, wherein said annulus patch is human muscle fascia, an autograft, an allograft, or a xenograft.

33. The method for repairing an intervertebral disc according to claim 31, further comprising the step of preparing said intervertebral disc, wherein said preparation step comprises the steps;

- a) identifying a damaged section of said disc nucleus; and
- b) removing said damaged section of said disc nucleus.

34. A method for repairing an intervertebral disc, wherein said intervertebral disc comprises a disc nucleus and a disc annulus, comprising the steps of;

- a) forming an aperture in said intervertebral disc annulus;
- b) inserting an annulus stent into said aperture, wherein said annulus stent comprises an elongated centralized vertical extension, a left and a right lateral extension along said centralized vertical extension's horizontal axis; and
- c) securing said annulus stent to said intervertebral disc annulus.

35. The method for repairing an intervertebral disc according to claim 34, wherein said step of forming said aperture in said disc annulus comprises the step of making a surgical incision into said disc annulus.

36. The method for repairing an intervertebral disc according to claim 34, wherein said step of inserting said annulus stent into said aperture comprises the steps of;

- a) compressing said left and right lateral extensions together;
- b) inserting said annulus stent into said aperture, such that an upper surface of said left and right lateral extensions conforms to an inside surface of said disc annulus; and

- c) positioning said centralized vertical extension within said aperture, such that said annulus stent may be secured to said disc annulus.

37. The method for repairing an intervertebral disc according to claim 34, wherein said step of inserting said annulus stent into said aperture comprises the steps of;

- a) compressing said left and right lateral extension together;
- b) rotating said annulus stent, such that said annulus stent may be laterally inserted into said intervertebral disc;
- c) inserting said annulus stent laterally through said aperture into said intervertebral disc;
- d) rotating said annulus stent within said intervertebral disc, such that an upper surface of said left and right lateral extensions conforms to an inside surface of said disc annulus; and

- e) positioning said centralized vertical extension within said aperture, such that said annulus stent may be secured to said disc annulus.

38. The method for repairing an intervertebral disc according to claim 34, further comprising a step of preparing said intervertebral disc, wherein said preparation step comprises the steps of inserting a set surgical screws into a pair of adjacent intervertebral, wherein said surgical screws comprise an eye hole located at the top of said surgical screw.

39. The method for repairing an intervertebral disc according to claim 38, wherein said step of securing said annulus stent to said intervertebral disc comprises the steps of threading a surgical suture through said eye hole on said surgical screw.

40. The method for repairing an intervertebral disc according to claim 34, further comprising the step of preparing said intervertebral disc, wherein said preparation step comprises the steps;

- a) identifying a damaged section of said disc nucleus; and
- b) removing said damaged section of said disc nucleus.

41. The method for repairing an intervertebral disc according to claim 40, wherein said step of inserting said annulus stent into said aperture comprises the steps of;

- a) compressing said left and right lateral extensions together;
- b) inserting said annulus stent into said aperture, such that an upper surface of said left and right lateral extensions conforms to an inside surface of said disc annulus;
- c) positioning said centralized vertical extension within said aperture, such that said annulus stent may be secured to disc annulus; and

- d) injecting a biocompatible fluid into said internal cavity, through said annulus stent.

42. The method for repairing an intervertebral disc according to claim 41, wherein said biocompatible fluid comprises a hygroscopic material.

43. The method for repairing an intervertebral disc according to claim 40, wherein said step inserting said annulus stent into said aperture comprises the steps of;

- a) compressing said left and right lateral extensions together;

- b) rotating said annulus stent, such that said annulus stent may be laterally inserted into said intervertebral disc;
 - c) inserting said annulus stent laterally through said aperture into said intervertebral disc;
 - d) rotating said annulus stent within said intervertebral disc, such that an upper surface of said left and right lateral extensions conforms to an inside surface of said disc annulus;
 - e) positioning said centralized vertical extension within said aperture, such that said annulus stent may be secured to disc annulus; and
 - f) inject a biocompatible fluid into said internal cavity, through said annulus stent.
- 44.** The method for repairing an intervertebral disc according to claim 43, wherein said biocompatible fluid comprises a hygroscopic material.

* * * * *