

J. A. WIDNER.
 METALLIC RAILWAY TIE.
 APPLICATION FILED MAR. 26, 1908.

903,252.

Patented Nov. 10, 1908

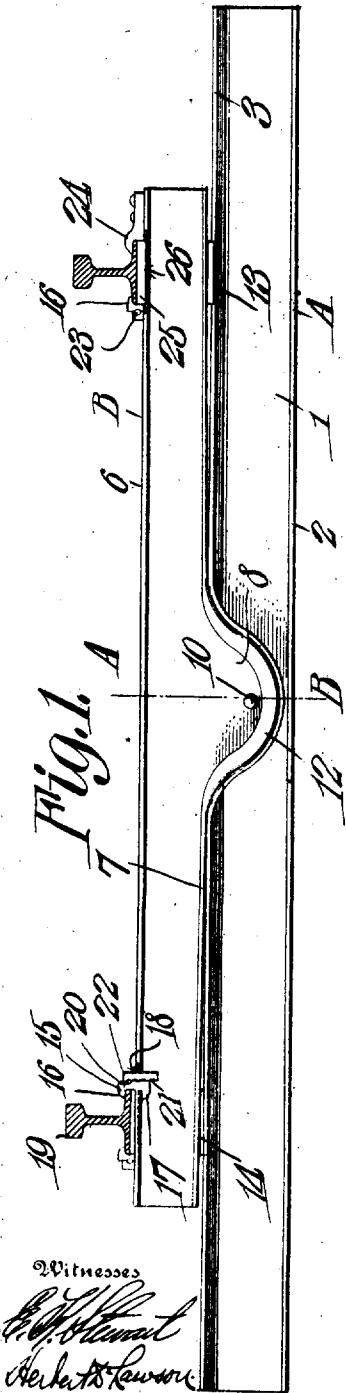

Witnesses
E. W. Stewart
Herbert S. Lawrence

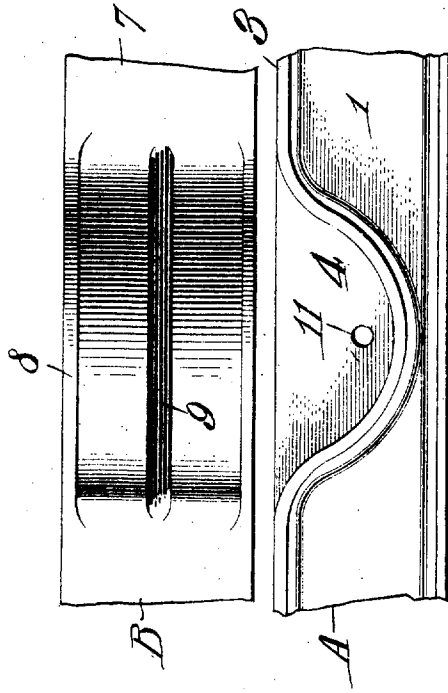

Fig. 3.

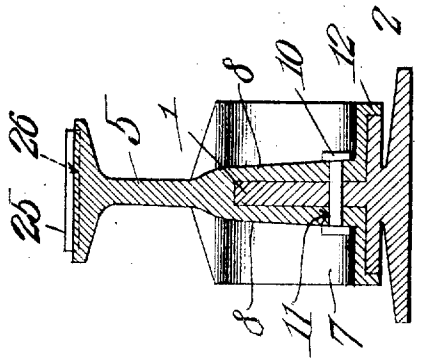

Fig. 2.

Inventor
John A. Widner, Jr.
 By *Chas. S. Co.*
 Attorneys

UNITED STATES PATENT OFFICE.

JOHN A. WIDNER, OF ALPENA, MICHIGAN.

METALLIC RAILWAY-TIE.

No. 903,252.

Specification of Letters Patent.

Patented Nov. 10, 1908.

Application filed March 26, 1908. Serial No. 423,424.

To all whom it may concern:

Be it known that I, JOHN A. WIDNER, a citizen of the United States, residing at Alpena, in the county of Alpena and State of Michigan, have invented new and useful Metallic Railway-Ties, of which the following is a specification.

This invention relates to metallic railway tie and its object is to provide an all-metal tie consisting of two movably connected members, one of said members being centrally supported and being disposed to yield when subjected to the weight of a car so as to constitute a cushion.

A further object is to provide a tie of this character having auxiliary cushioning means interposed between the members thereof.

With these and other objects in view the invention consists of certain novel features of construction and combinations of parts which will be hereinafter more fully described and pointed out in the claims.

In the accompanying drawings is shown the preferred form of the invention.

In said drawings: Figure 1 is a side elevation of a tie constructed in accordance with the present invention, one end portion of the cushioning member of the tie being broken away. Fig. 2 is an enlarged section on line A—B, Fig. 1. Fig. 3 is a view showing in side elevation and in bottom plan the middle portions of the base and cushioning members respectively of the tie.

Metallic railway ties as heretofore constructed have generally been objectionable because they have not usually been capable of producing the desired cushioning effect without the use of springs, wood, or other similar devices of an unreliable nature. The present invention, however, overcomes all such defects incident to metallic ties and consists of a base member A consisting of an upstanding longitudinal web 1, oppositely extending base flanges 2, and oppositely extending top flanges 3. These flanges 3 are parallel with the base flanges 1 for the greater part of their lengths but at the center of the base A the top flanges are curved downwardly to form recesses 4 at opposite sides of the web 1 as clearly indicated in Fig. 3. The member A may be rolled or otherwise formed from suitable metal and it is designed to make it of the same length as the ordinary railway tie.

The upper or cushioning member of the tie has been indicated at B and consists of an

upstanding longitudinal web 5 having oppositely extending top flanges 6 and oppositely extending base flanges 7. That portion of the web located at the center of the member B is extended downwardly below the planes occupied by the flanges 7 so as to constitute a rocker 8 which is thickened as indicated in Fig. 2 and provided with a longitudinal slot 9 to receive that portion of web 1 located between the recesses 4. The rocker 8 bears within the two recesses 4 and constantly contacts with the bottoms of the recesses.

In order that the members A and B may be held against separation a rivet or other connecting device 10 is extended through registering openings 11 within the web 1, and the rocker 8 as indicated in Fig. 2. Those portions of the flange 7 formed upon the rocker 8 are extended downwardly as indicated at 12 so as to lap the curved portions of the flanges 3 and thus prevent dirt, etc., from working into the recesses 4.

As clearly indicated in Fig. 1 the lower face of the member B is inclined upwardly toward the ends of said member from the rocker 8, the inclination being such that the member B can be rocked so as to bring either inclined portion of the bottom thereof flat upon the adjoining portion of the member A. Sockets 13 are formed in the upper face of member A and below the end portions of the member B and constitute seats for cushion blocks 14 of wood or other suitable material. These blocks are normally spaced from the member B.

Arranged upon each end portion of the member B are means for fastening a rail thereto. These fastening means constitute the subject matter of a co-pending application filed on March 26, 1908, Serial No. 423,425. As shown in the drawings each of these fasteners consists of a plate 15 having jaws 16 and 17 at the ends thereof and each plate is designed to be inserted through a slot 18 in one of the flanges 6 and then shifted so that the jaw 16 will lap one of the base flanges of a rail 19 while jaw 17 will engage the lower surface of the flange 6. A notch 20 is formed in the longitudinal edge of plate 15 and is designed to register with any one of a series of notches 21 formed in one edge of a tapered key 22 designed to be driven into the slot after plate 16 has been positioned therein. After this key has been forced into the slot a rivet 23 or other fastening device is secured within the registering notches 20 and

21 so as to prevent the key 22 from being lifted out of the slot and freeing the plate 16. As shown at the left of Fig. 1 one of these fastening devices can be placed in engagement with each base flange of the rail but if preferred, and as shown at the right of Fig. 1, the outer base flange of each rail can be engaged by a fixed jaw 24 secured to or formed with the upper surface of the member B. In order that the rails 19 may be further cushioned, blocks 25 of wood or other suitable material are seated within recesses 26 in the upper face of member B and the rails are designed to rest upon these blocks, as shown. When the car is passing over the rails which are fastened to the tie the upper member B of the tie will bend downward at its ends until stopped by coming into contact with the cushions 14. By mounting the members A and B so that they have relative movement the elasticity of the tie is greatly increased. It will be seen that the rocker 8 bears directly upon the bottoms of the recesses 4 and therefore the pin or rivet 10 receives no strain whatever but merely acts to hold the parts together.

It is of course to be understood that the rail fasteners herein described can be used in connection with any form of tie having lateral flanges and, if desired, the upper member B can be dispensed with and said fasteners placed in slots formed in the flanges 3 of member A. Of course, with this arrangement the tie would lose its resiliency.

What is claimed is:

1. A metallic railway tie comprising a relatively fixed member, a centrally pivoted and supported cushioning member balanced thereon, and rail engaging devices carried by the end portions of said cushioning member.

2. A metallic railway tie comprising a relatively fixed member, and a centrally pivoted and supported relatively movable cushioning member mounted thereon.

3. A metallic railway tie comprising a relatively fixed member, a centrally pivoted and supported cushioning member mounted to rock thereon, rail engaging devices upon the end portions of the cushioning member, and auxiliary cushioning devices interposed between the end portions of the two members.

4. A metallic railway tie comprising a relatively fixed member, a centrally pivoted cushioning member supported at its center and disposed to rock upon the fixed member, and rail engaging devices upon the end portions of the cushioning member.

5. A metallic railway tie comprising a relatively fixed member having a recess therein, a rail engaging cushioning member having an integral rocker movably mounted within the

recess, and rail engaging devices upon the cushioning member and at opposite sides of the rocker.

6. A metallic railway tie comprising a relatively fixed member having a recess, a rail engaging cushioning member having an integral central rocker movably mounted within the recess, the end portions of said cushioning member being normally spaced from the fixed member.

7. A metallic railway tie comprising a relatively fixed member having a recess, a cushioning member having a central rocker movably mounted within and bearing upon the bottom of the recess, and means for pivotally connecting the rocker to the fixed member.

8. A metallic railway tie comprising a relatively fixed member having a recess, a cushioning member having a centrally located rocker movably mounted within and bearing upon the bottom of the recess, means for pivotally connecting the fixed member and the rocker, and rail engaging devices upon the cushioning member at opposite sides of the rocker.

9. A metallic railway tie comprising a relatively fixed member, a rail engaging cushioning member bearing thereon at its center and having its lower face inclined toward its ends away from the fixed member, said cushioning member being mounted to rock relative to the fixed member, and rail engaging devices carried by the end portions of the cushioning member.

10. A metallic railway tie comprising a relatively fixed member, a centrally supported cushioning member mounted thereon and having its end portions spaced from the fixed member, and auxiliary cushioning devices interposed between the spaced portions of the members.

11. In a metallic railway tie the combination with a relatively fixed member comprising an upstanding web and top flanges extending laterally therefrom, said flanges being extended downwardly upon opposite faces of the web to form central side recesses; of a cushioning member having a longitudinally grooved rocker seated within the recesses and straddling the web, said cushioning member having its end portions normally spaced from the fixed member.

In testimony that I claim the foregoing as my own, I have hereto affixed my signature in the presence of two witnesses.

JOHN A. WIDNER.

Witnesses:

E. W. CADY,
JAS. M. WALKER.