

G. W. PARSHALL.

Car Coupling.

No. 23,698.

Patented Apr. 19, 1859.

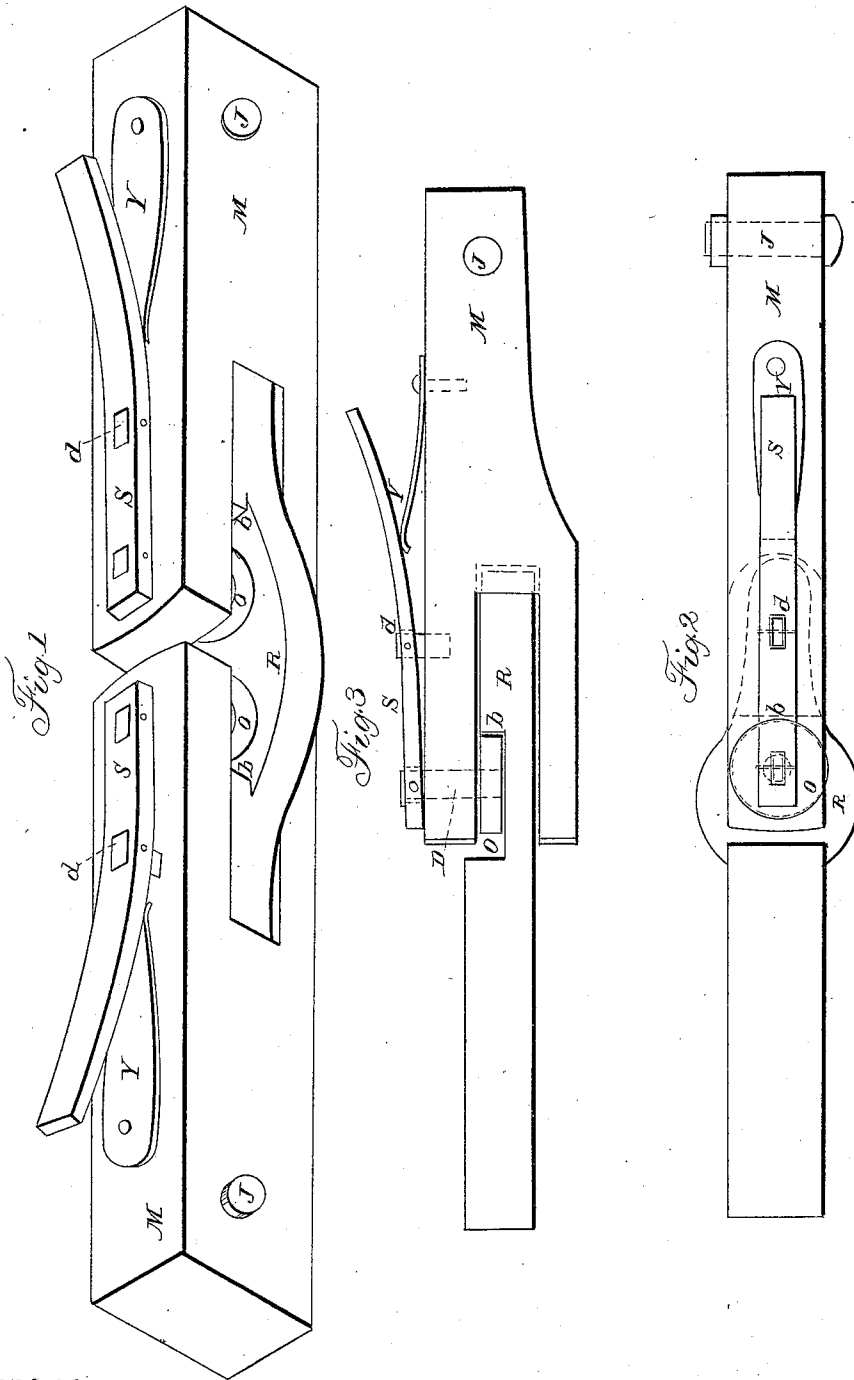

Witnesses:  
Samuel Harper  
Washington & Son

Inventor:  
George W. Parshall

# UNITED STATES PATENT OFFICE.

GEORGE W. PARSHALL, OF MIDDLEFIELD, NEW YORK.

## RAILROAD-CAR COUPLING.

Specification of Letters Patent No. 23,698, dated April 19, 1859.

*To all whom it may concern:*

Be it known that I, GEORGE W. PARSHALL, of the town of Middlefield, in the county of Otsego and State of New York, have invented a new and Improved Car-Coupling; and I do hereby declare that the following is a full and exact description thereof, reference being had to the annexed drawings, making a part of this specification, in which—

Figure 1st is a perspective view, Fig. 2nd is a plan view and Fig. 3rd is a side elevation.

Same letters represent corresponding parts in the several figures.

The nature of my invention consists in constructing a coupling by which the cars can be all detached simultaneously if required, and if a car gets off the track it will detach itself from the others.

To enable those skilled in the art to make and use my invention I will describe its construction and operation.

It may be constructed of any suitable material.

M, is a head piece which is attached to the buffer of the car; it is constructed with a slot in one end.

R, is the tongue which fits and operates in said slot; the end of said tongue is tapered and rounded and fits in a corresponding receptacle in the head piece M, forming a kind of knuckle joint.

O, is a friction wheel which is held in place by the coupling pin D.

S, is a lever attached to the coupling pin; it works on a fulcrum at *d*.

Y, is a spring which operates against the lever S, and prevents the coupling pin from coming out of the wheel and releasing the tongue.

By having a rod or any suitable device

connected to the levers S, all the cars can be detached simultaneously when desired.

To use my invention, the head piece M may be let into the buffer of the car as far or a little farther than the commencement of the slot in the said head piece, with sufficient room to play up and down to allow for the rise and fall of the cars above and below each other but must not be allowed much side play; and it is secured to the buffer by the bolt J.

To attach the cars, the tongue R is put within the slot in the head piece M, and the friction wheel is placed on said tongue under the coupling pin, and the said pin fits in a hole in the wheel O and is held there by the spring Y.

The shoulder *b*, of the tongue operates against the wheel O, and is held from drawing out by the said wheel while the head piece and tongue are kept in a straight position to each other; but if the tongue is drawn to one side as would be the case should a car be thrown from the track it releases itself. They can be constructed to release at any desired angle.

The wheel may be connected to the pin or it may be a separate piece as desired; and some other suitable device might be used in place of the lever and spring.

What I claim as my invention and desire to secure by Letters Patent is—

I claim the construction and combination of the head piece M, tongue R, wheel O, and pin D, arranged and operating as described and set forth for the purpose specified.

GEORGE W. PARSHALL.

Witnesses:

SAMUEL HARPER,  
GARRET J. OLENDORF.