

J. SHOLL.  
Bee Hive.

No. 1,402.

Patented Nov. 9, 1839.

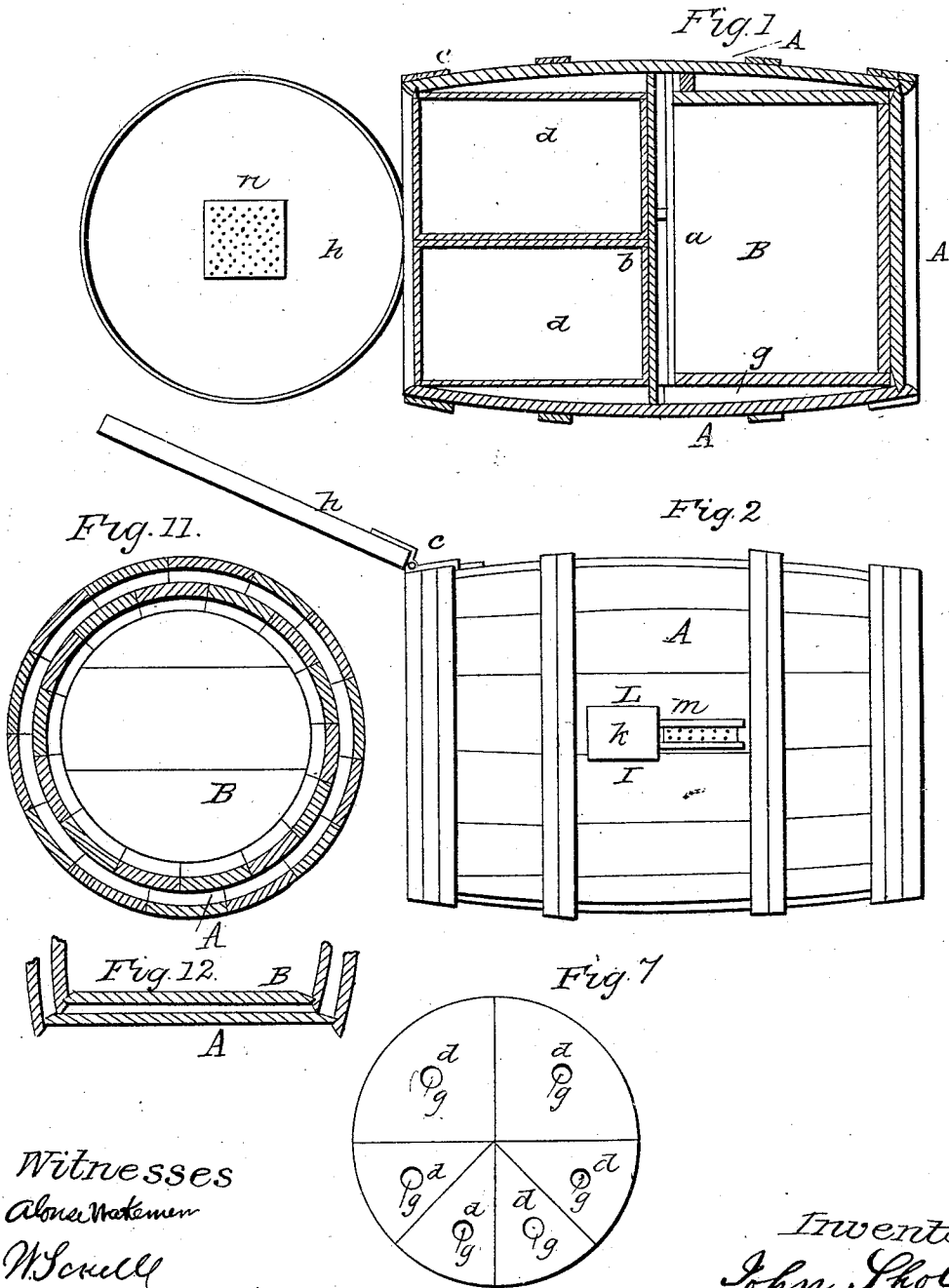

Witnesses  
Abner Wakeman  
W. Scull

Inventor  
John Sholl



# UNITED STATES PATENT OFFICE.

JOHN SHOLL, OF NEW YORK, N. Y.

## CONSTRUCTION OF BEEHIVES.

Specification of Letters Patent No. 1,402, dated November 9, 1869.

*To all whom it may concern:*

Be it known that I, JOHN SHOLL, of the city of New York, in the State of New York, have invented or discovered a new and useful Manner of Constructing a Combined Bee House or Hive, which is simple in its arrangements and possesses by the combination of its respective parts many advantages over those bee houses or hives previously in use; and I do hereby declare that the following is a full and exact description thereof.

The outer case of my hive consists, in general, of a barrel, which may be of the ordinary size of a flour barrel, or of any other size that may be preferred; or, instead of a barrel, a case of any form, or size, may be used which will admit of the arrangement of the respective parts to be described; in the drawings that accompany this specification I have represented my house, or hive, as having a barrel for its outer case, and shall so speak of it in further describing the same. This barrel is to be placed so as to stand horizontally, although it may be used vertically; one of its heads is to be removed, but the other is to remain in place; that which is removed is to be replaced by a hinged cover. The barrel may be placed upon a suitable stand, or it may be slung to a branch of a tree, or otherwise suspended, so as to be capable of being inverted, or turned around, at pleasure. The part of the barrel toward the stationary end is to be occupied by a separate box, or hive, either square, or round, or in any other preferred form; this box, or hive, is to be secured to the stationary head of the barrel by means of screws, or otherwise. It is to extend to about the middle of the barrel, there being in all cases a space between the sides of the two, which space will necessarily exist when the interior box is square. In front of this box hive, the space in the barrel is to be occupied by a number of separate boxes, extending from it to the open end of the exterior case, which separate boxes are removable at pleasure, so that when filled with honey, they may be taken away, and others substituted for them. They are so constructed and arranged as that a communication between them and the main box may be opened, or closed, at pleasure, by means to be presently described.

In Figures 1 and 2, of the accompanying drawings, A, A, represent the exterior case, 55 or barrel, A<sup>1</sup>, being its stationary, C its upper end, and h its hinged end, or cover. Fig. 1, is a sectional view through the axis of the barrel; B, being the square, or other formed, box, or hive, the open end of said 60 box being toward the open end of the barrel; d, d, are the removable boxes within which the bees are to build after having filled the main box, or hive, B. This box, or hive, is to be furnished with a top, or cover, 65 which has sliding valves affixed to it, by which I govern the communication between the box B, and the respective boxes d, d, standing in front of it; this cover, with its valves, is shown at Fig. 4. Within this 70 cover, at, or near, the open end of the box B, I place movable cross bars, or grating, as seen at a, a, Fig. 3; c, c, are buttons, hooks, or cleats, by which the cover b, b, may be held in front of the grating a, a; the cover 75 b, b, I make in three parts, so that it may be readily removed when desired. Fig. 4, shows the interior side of this cover b, b, for the purpose of representing the valves, or shutters, by which the openings p, p, 80 made through it, may be either left free, or closed, at pleasure; e, e, e, are the valves, or shutters, turning upon pins, or pivots, and are made of tin, or other thin metal; they are held in place by straps of metal. To 85 open and close these valves, there are strings f, f, attached to each of their sides, by means of which they may be drawn in either direction. r, r, r, represent wire staples, through which these strings may pass in their way to 90 the holes s, s, s, which holes, however, ought to be made close to the edges of the cover b, b, as the strings may then extend up directly through them, against the inside of the staves, to the top, or end, e, of the bar- 95 rel, where their ends are secured in any convenient way, allowing them to be pulled at pleasure; it will be manifest that these strings may be passed directly through holes in the sides of the barrel, but in that case 100 they will be exposed on its outside, which would be attended with inconvenience.

The boxes marked d, d, in the respective figures, may vary in form; in Fig. 5, they are represented as rectangular; in Figs. 6 105 and 7, they are shown as triangular, one of

their sides being curved, to adapt them to the form of the barrel; in each of these figures their inner ends are represented, there being in that end openings *q, q, q*, to which the openings *p, p*, in the cover *b, b*, are to correspond. The cases *d, d*, may be made of thin wood, fastened together in any convenient way. In their sides I usually insert one or two pieces of glass, for the purpose of examining the interior, and ascertaining its contents. When either of the boxes *d, d*, is removed, it will frequently happen that a number of bees will be within it, and to prevent any unpleasant result from this I place a shutter, as shown at *v*, Fig. 6, on the ends of each of them, in such manner as that it may be made to cover the holes *q, q*, and in the instant of removing it I close this cover.

The entrance for the bees is through the side of the barrel, or case, at, or near to its middle, so as to lead into the area, or space, below the cover *b, b*, and the opening into the box, or hive, *B*. This entrance I cover with a metal shield *h*, Fig. 2, shown also on a larger scale at Fig. 8. This shield is arched so as to stand up from the cask along its edges *l, l*, where a number of slits are made along it, and the pieces between said slits are twisted around, and thus leaving spaces for entrance, as seen at Fig. 9. The opening *i*, through the cask, I cover with a perforated slide *m*, which when pushed in will inclose the bees, and yet allow of space for ventilation.

The lid *h*, which is hinged to the open end *C*, of the cask is furnished with a hasp and staple for the purpose of locking it up. Through this lid there is an opening which is covered by wire gauze, or perforated tin, as at *n*, for the purpose of ventilation; and this I also provide with a sliding cover by which the amount of ventilation may be adjusted. I make a similar opening in the bottom *A*<sup>1</sup>, which is ordinarily kept closed; but when it is desired to produce thorough ventilation, I open this and give a clear passage for air from end to end of the barrel.

It has already been observed that I do not intend to confine myself to the use of a square box in the bottom of the barrel; in fact I prefer, in commencing a new hive, to have said box round, or like a half barrel, occupying nearly all the inner area, leaving only sufficient space between it and the outer case for a stratum of air, to serve as a non-conductor of heat. In Figs. 11 and 12, this arrangement is represented, there being an air space not only between the sides of the two, but also between the bottom of the inner half barrel and the fixed head of the case.

Beneath and around the box *B* the unoccupied space in the barrel becomes a receptacle for any filth or dead bees from above;

where a square box is used the lower space between the sides of this and of the barrel will allow ample room for their removal; and in this case a small door *o* Fig. 4, making part of the partition *b, b*, may be raised to obtain access thereto. Instead of the door *o*, closing the space *g*, it may be occupied by a drawer, which when pulled out will bring the accumulated filth with it.

In the event of the bee moth, or any other enemy of bees, obtaining access to the interior, so as to make it needful to remove the bees, or clear the hive, I use the following means and apparatus for this purpose. I take a small metal, or earthenware, plate, as shown at *t*, Fig. 10, and inclose it in a gauze bag *u*, and I ignite upon this plate a portion of that vegetable matter known under the name of fungus, or puff ball, which will, temporarily, intoxicate the bees, having removed the outer cases and middle partition from the barrel, I turn it so that the end *C*, shall be downward, and then hang the bag containing the ignited puff ball within it; the bees will thus be made to fall down on a sheet, or cloth, placed to receive them. The whole interior may then be thoroughly cleansed, or a fresh cask and hive may be substituted, and the bees transferred to it. The fresh air will quickly revivify them, and prepare them for taking their stations in a clean, or new hive.

Having thus fully described the manner in which I construct my combination bee house, or hive, and also pointed out the uses of the respective parts thereof, what I claim as constituting my invention, and desire to secure by Letters Patent, is as follows:

1. I claim the mode of arranging the valves *e, e*, in the partition *b, b*, by placing a separate valve, so as to govern each of the holes leading through said partition to the boxes *d, d*; each of said valves moving on a pivot at one of its ends, and having strings attached to each of its sides on the opposite end, for opening, or closing, said valves, the strings extending to the outside of the hive, and passing through, or up, the case, so that they may be readily moved in either direction, substantially as set forth.

I do not claim to be the first who has used valves, or slides, to cover openings in partitions between separate hives, or boxes, to allow of, or to prevent, the passing of bees from one to the other; but I do claim, as above stated, the combination and arrangement of the respective parts by which I govern such openings.

2. I claim, in combination, the shield *h*, and the perforated slide *m*; the shield *h* being armed with teeth, or notches, on its edges, for allowing an entrance to the bees, and protecting them from vermin; and the slide *m*, having perforations which serve for ventilating the hive when said slide is closed.

3. I also claim, in combination therewith,  
the opening in the bottom of the barrel, cov-  
ered with perforated metal and a slide, or  
valve, by the opening of which a perfect  
5 ventilation may be established from end to  
end of the barrel.

4. I claim, likewise, the using of the ar-

ticle Lycopodium, called also fungus or puff  
ball, in the manner herein set forth, for the  
purpose of removing the bees from the hive. 10  
JOHN SHOLL.

Witnesses:

THOS. P. JONES,

W. THOMPSON.