



INTERNATIONAL APPLICATION PUBLISHED UNDER THE PATENT COOPERATION TREATY (PCT)

<p>(51) International Patent Classification ⁶ : G01N 27/26, 27/447</p>	<p>A1</p>	<p>(11) International Publication Number: WO 96/23213 (43) International Publication Date: 1 August 1996 (01.08.96)</p>
<p>(21) International Application Number: PCT/US96/01613 (22) International Filing Date: 23 January 1996 (23.01.96) (30) Priority Data: 08/376,853 23 January 1995 (23.01.95) US (71)(72) Applicants and Inventors: MURRAY, Anthony, J. [AU/US]; Pharmacia U.S. Inc., 800 Centennial Avenue, Piscataway, NJ 08855 (US). STEGEMANN, Josef [DE/DE]; Hausackerweg 28, D-69118 Heidelberg (DE). ANSORGE, Wilhelm [DE/DE]; Heidelberg Strasse 49, D-69251 Gaiberg (DE). (74) Agent: SCHAEFER, Kenneth, R.; Norris, McLaughlin & Marcus, P.O. Box 1018, Somerville, NJ 08876-1018 (US).</p>		<p>(81) Designated States: CA, JP, European patent (AT, BE, CH, DE, DK, ES, FR, GB, GR, IE, IT, LU, MC, NL, PT, SE). Published With international search report.</p>

(54) Title: ANALYSIS OF BIOLOGICAL MOLECULES

(57) Abstract

Apparatus (12) and method for detection and separation of biological molecules that are tagged with a photosensitive label. Molecules are separated by size, in both horizontal and vertical planes, in parallel electrophoretic path ways (18) in a gel matrix (16). An electric potential is applied to the gel matrix (16) while laser light excites the molecules as they migrate in a predetermined direction. The output light signals emitted from the excited molecules are detected, collected, stored and analyzed using a monitor (36), controller (35) and a digital data processor (37).

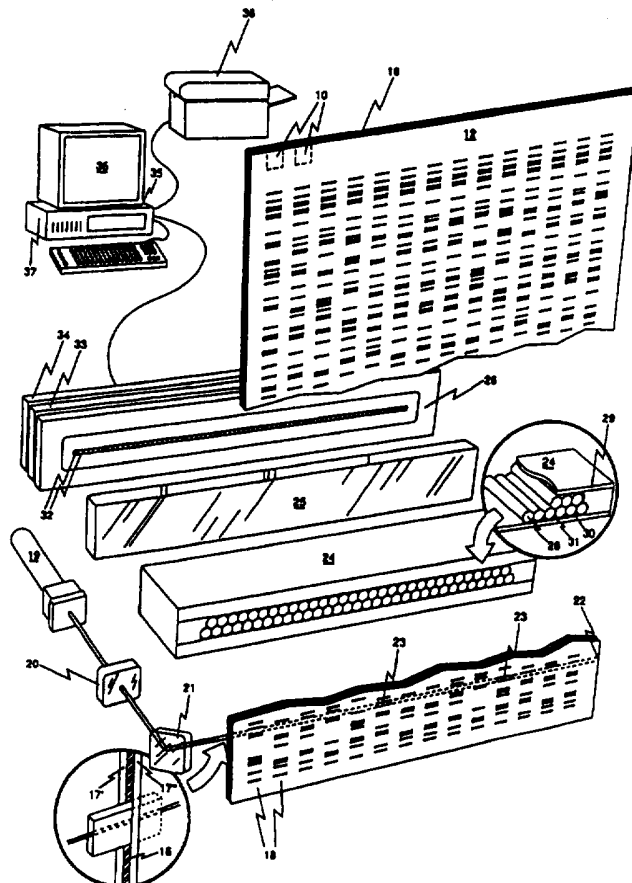

FOR THE PURPOSES OF INFORMATION ONLY

Codes used to identify States party to the PCT on the front pages of pamphlets publishing international applications under the PCT.

AM	Armenia	GB	United Kingdom	MW	Malawi
AT	Austria	GE	Georgia	MX	Mexico
AU	Australia	GN	Guinea	NE	Niger
BB	Barbados	GR	Greece	NL	Netherlands
BE	Belgium	HU	Hungary	NO	Norway
BF	Burkina Faso	IE	Ireland	NZ	New Zealand
BG	Bulgaria	IT	Italy	PL	Poland
BJ	Benin	JP	Japan	PT	Portugal
BR	Brazil	KE	Kenya	RO	Romania
BY	Belarus	KG	Kyrgystan	RU	Russian Federation
CA	Canada	KP	Democratic People's Republic of Korea	SD	Sudan
CF	Central African Republic	KR	Republic of Korea	SE	Sweden
CG	Congo	KZ	Kazakhstan	SG	Singapore
CH	Switzerland	LI	Liechtenstein	SI	Slovenia
CI	Côte d'Ivoire	LK	Sri Lanka	SK	Slovakia
CM	Cameroon	LR	Liberia	SN	Senegal
CN	China	LT	Lithuania	SZ	Swaziland
CS	Czechoslovakia	LU	Luxembourg	TD	Chad
CZ	Czech Republic	LV	Latvia	TG	Togo
DE	Germany	MC	Monaco	TJ	Tajikistan
DK	Denmark	MD	Republic of Moldova	TT	Trinidad and Tobago
EE	Estonia	MG	Madagascar	UA	Ukraine
ES	Spain	ML	Mali	UG	Uganda
FI	Finland	MN	Mongolia	US	United States of America
FR	France	MR	Mauritania	UZ	Uzbekistan
GA	Gabon			VN	Viet Nam

ANALYSIS OF BIOLOGICAL MOLECULES

Introduction

5 Deoxyribonucleic acid (DNA) consists of two linear strands
composed of individual nucleosides which are linked to one
another by phosphodiester bonds. In its natural state, DNA
exists in the form of complementary chains of nucleosides
interconnected as a double helix. The double helix is held
10 together by the hydrogen bonds formed between the individual
complementary nucleosides situated opposite each other.
Nucleotides (composed of a nitrogenous purine or pyrimidine
base, a deoxyribose sugar and a phosphate group) are the basic
building blocks of the molecule and their sequence defines the
gene and ultimately the protein encoded by the gene. There
15 are four nucleotides - deoxyadenosine (A) which pairs with
thymidine (T) and deoxyguanosine (G) which pairs with
deoxycytidine (C).

The ability to sequence DNA and ribonucleic acid (RNA) has
20 given scientists a valuable tool with which to dissect the
genomes of many viruses, bacteria, plants and animals.
Indeed, the development of improved and more efficient
procedures for the sequence analysis of DNA and RNA has been
a crucial element in many of the greatest advances in
recombinant DNA technology and genetic engineering.

25 DNA sequencing technology has now reached the level of
sophistication whereby the scientific establishment has been
able to undertake perhaps its most ambitious project to date -
the DNA sequence analysis of the entire 3,000,000,000 bases
of the human genome. Although, in recent years, DNA
30 sequencing technology has seen many advances, both in the
protocols used for sequencing reactions themselves and in the
means used to visualize the products of these reactions, it is
clear that improvements must be made if the task of sequencing
the human genome is to be completed within a reasonable length
35 of time and at an affordable cost. The current invention
relates generally to an apparatus and methods for the analysis

of labeled biological molecules. The flexibility and versatility of the current invention allow it to be used in conjunction with a number of different methods of electrophoretic separation, e.g. slab, channel and capillary means. As electrophoretic methods and procedures become more efficient and sensitive, such versatility and flexibility will be of great importance in extending the current invention's utility and viability as a research and diagnostic tool. Capillary electrophoresis techniques, for example, can be as much as 10,000 times more sensitive than traditional means of electrophoretic detection and be so sensitive as to be able to detect quantities of biological material approaching single molecule quantities.

As detailed below, the invention has particular application to the sequence analysis of DNA and, in this regard, an apparatus for the improved detection and interpretation of the sequence data so derived is described.

BACKGROUND OF THE INVENTION

The determination of the sequence of DNA has been undertaken utilizing two basic approaches: the chemical degradation method of Maxam et.al. (Proceedings of the National Academy of Sciences, Volume 74, pgs. 560-564 (1977)); and the dideoxy chain termination method of Sanger et.al. (Proceedings of the National Academy of Sciences, Volume 74, pgs. 5463-5467 (1977)). The two methods are still widely used, one having advantages over the other depending on specific circumstances. In both the chemical degradation and chain termination methods of sequencing DNA it is necessary to generate labeled DNA fragments, each having a common origin and each terminating with a known base. The labeled-DNA fragments which are a product of either procedure are separated according to size by high resolution gel electrophoresis and a so-called "sequence ladder" is thus generated upon visualization of the gel by exposure to photographic film or other image storage means. Gel electrophoresis usually involves loading the labeled-DNA

fragments onto one end of a polyacrylamide gel formed between two glass plates in such a way that, at one end, it contains slots or wells for the placement of samples.

5 During the loading procedure, both ends of the polyacrylamide gel are immersed in an electrolyte solution contained in electrode tanks. When sample loading is completed, a voltage from a power supply is applied across the electrode tanks and thus across the polyacrylamide gel. The applied voltage electrophoreses the labeled-DNA samples
10 through the polyacrylamide gel and so the fragments migrate according to size.

The expense of generating sequence information in terms of both human labor and reagent costs, even when advanced sequencing protocols are combined with the most efficient
15 methods of fragment separation such as those previously discussed, as well as the immense value of such information for research and diagnostic purposes, has led to a number of attempts to make the procedure more efficient. To this end, automation of the methods used for DNA sequencing has proven
20 to be an attractive and often successful proposition. Improvements in the dideoxy chain termination procedure (e.g. Sanger et.al., Journal of Molecular Biology, Volume 143, pgs. 161-178 (1980); Schreier et.al., Journal of Molecular Biology, Volume 129, pgs. 169-172 (1979); Smith et.al., Nucleic Acids Research, Volume 13, pgs. 2399-2412 (1985); Smith et.al., Nature, Volume 321, pgs. 674-679 (1987); Prober et.al., Science, Volume 238, pgs. 336-341 (1987); Church et.al., Science, Volume 240, pgs. 185-188 (1988); and Connell et.al., Biotechniques, Volume 5, pgs. 342-348 (1987)) have made it the
25 method of choice for automated DNA sequencing machines and other rapid sequencing applications.
30

Manual DNA sequencing procedures and some of the early attempts at automation utilized radiolabeling of fragments i.e. incorporating nucleotides containing a radioactive label
35 such as ³²P or ³H into the DNA fragment. For example, U.S. Patent No. 4,707,235 issued to Englert and Wheeler on November

17, 1987 describes a method and apparatus for determining the nucleotide sequence of labeled DNA fragments. In the preferred embodiment of the '235 patent, samples containing radioactively-labeled DNA fragments are electrophoresed through a gel matrix. As the labeled fragments migrate to the bottom of the gel, they pass the window of a detector. Ionizing radiation from the radiolabeled fragments of sufficient energy passes through the window, producing free electrons in the gaseous environment of the detector. The free electrons are accelerated towards an anode wire which, in response, produces electronic signals. The electronic signals so generated are ultimately stored and interpreted by means of a computer.

However, as the availability and efficiency of fluorescent-labeling techniques improved, detection of DNA sequence information by fluorescence became the method of choice, especially in fully automated systems. Excitation of fluorophore-labeled DNA fragments during electrophoresis through a gel matrix combined with fluorescence detection systems and computer-based methods of data interpretation and storage have allowed the generation of sequence information in an increasingly more labor efficient and cost effective manner.

A variety of strategies can be utilized in order to derive DNA sequence data using DNA fragments labeled with fluorescent dyes e.g. using only one fluorescent dye, and sequence information obtained from a parallel analysis of four lanes on a gel (Ansorge et.al., Journal of Biochem. Biophys. Methods, Volume 13, pgs. 315-323 (1986); Ansorge et.al., Electrophoresis, Volume 13, pgs. 616-619 (1992)); using four dyes, each associated with a specific base, and the sequence information obtained from analysis of one lane on the gel (Smith et.al. Nature Volume 321, pgs. 674-679 (1986); with the use of different dyes, T7 DNA polymerase, manganese, and inorganic pyrophosphatases in combination with an analysis of peak heights (see U.S. Patent No. 5,124,247 issued to Wilhelm

5 Ansorge on June 23, 1992; Tabor and Richardson, Journal of Biological Chemistry, Volume 265, pgs. 8322-8329 (1990)); or with the use of different dyes in combination with a two-laser-two-window automated approach for maximum signal and dye discrimination (Carson et.al., Analytical Chemistry, Volume 85, pgs. 3219-3226 (1993)).

10 In the majority of systems utilizing fluorescent labeling techniques, the fluorescent dyes are attached either to a primer, e.g. Smith et.al. (1987, cited above); the base of a terminal dideoxynucleotide, e.g. Prober et.al. (1987, cited above); or to internal nucleotides of the DNA fragment (see PCT Application WO 93/03180, Wilhelm Ansorge and Hartmut Voss).

15 The latter method of labeling utilizes labeled deoxynucleoside triphosphates e.g. deoxyadenosine triphosphate (dATP), and is particularly advantageous in that it allows the use of unlabeled primer. When combined with optimal primer design, fragment labeling with fluorescent dATP enables sequence information to be read beyond 1000 bases from a single lane or group of four lanes after electrophoresis of the labeled DNA fragments through a gel matrix. The increased amount of sequence data that can be obtained from a single gel is due, in part, to the increased efficiency of DNA fragment labeling disclosed in the Ansorge and Voss protocol.

20 No matter the labeling procedure, the labeled fragments, as discussed above, are loaded onto a gel for electrophoretic separation and the DNA sequence is determined from the pattern of fluorescent signals emitted by the fragments as they pass a detector during the separation process.

25 Critical components of automated DNA sequencing machines are the optical systems used to collect and focus fluorescent light onto the fluorescence detection system and the fluorescence detection systems themselves. Numerous approaches have been taken in the design of these components. With regard to the fluorescence detection systems, two types have shown considerable utility in automated DNA sequencing

machines - those which use CCDs and those which use diode/amplifier assemblies as the primary means of fluorescence detection.

5 Linear CCDs in the CCD-based fluorescence detectors are divided into a vast number of photosensitive cells, often as many as 5,000. Two-dimensional CCDs, which can also be utilized in the CCD-based fluorescence detectors, contain even more such photosensitive cells. Information from the cells can be analyzed on an individual or collective basis. This
10 ability imparts a high data collection sensitivity and efficiency to the detection system. The sensitivity of the CCD-based detector systems is increased when they are combined with optical systems which can efficiently capture the fluorescent light emitted by excited fluorophore-labeled DNA
15 fragments as they migrate through the matrix of a gel.

Although diode/amplifier-based detection systems have been incorporated into the design of a number of automated DNA sequencing systems, their utility has been limited by physical constraints. In such DNA sequencing machines, each lane on
20 the gel must correspond to a discrete diode which is separately combined with a signal amplifier. In the discrete diode/amplifier detection systems, any increase in the number of lanes on the gel must be accompanied by a concomitant increase in the number of diodes. Recent innovations such as
25 those which have allowed the integration of multiple amplifiers and diodes into a single unit have enabled diode/amplifier-array-based fluorescence detection systems to overcome some of the disadvantages associated with their use. As with the CCD-based detection systems, the sensitivity of
30 the integrated diode/amplifier-array-based fluorescent detection systems can also be increased when they are combined with optical systems which can efficiently capture fluorescent light emitted by excited fluorophore-labeled DNA fragments as they migrate through the matrix of the gel.

35

AUTOMATED DNA SEQUENCING MACHINES

At present, the commercially available automated DNA sequencing machines can be divided into two types - those which use a scanning laser means to excite fluorescence and those which use fixed laser means to achieve this goal.

Scanning Fluorescence Detection

DNA sequencing machines which rely on a scanning laser excitation means are exemplified by the apparatus described in U.S. Patent No. 4,811,218 issued to Hunkapillar et.al. on March 7, 1989.

The '218 patent describes an automated DNA sequencing apparatus which uses a laser as the source of the fluorescence-inducing electromagnetic radiation. An optical excitation system which moves horizontally on a motorized translational stage consists essentially of a focusing telescope which decreases the size of the incoming laser beam and then focuses it onto each of the gel lanes, independent of one another. A collector lens system collects a portion of the fluorescence from the labeled DNA fragments on the gel and directs it toward a filter wheel made up of four filters. Located at the focus of the collector lens is a Fabry lens group, configured so as to image the collected light onto the active area of a photomultiplier tube. The photomultiplier tube generates a signal which can be interpreted by appropriate means and converted to readable DNA sequence information.

Light from the laser is launched into the gel lanes at the Brewster angle. This detection means calls for utilization of a laser of high power. The use of the high power laser for the purposes of illumination is expensive and results in a higher cost for the apparatus.

Another significant disadvantage of the apparatus described in the '218 patent involves the integration time for the information contained in the lanes of the gel which are scanned. A band on a gel containing a labeled fragment is examined for a shorter time in a laser scanning excitation

system than in a static laser excitation system. This shorter scanning time results in a shorter detector integration time because the laser must not only scan each lane but also scan at different emission wavelengths to collect sufficient data points in order to make a base determination. In addition, the use of mechanical means for scanning causes a reduction in the system's overall reliability.

DNA sequencing machines utilizing the laser scanning means of excitation are marketed by Applied Biosystems Inc. of Foster City, California and Li-cor, Inc. of Lincoln, Nebraska. The Li-cor apparatus uses an infra-red dye, an avalanche diode and a mass produced semiconductor laser instead of the expensive Argon laser. Although these improvements have reduced the cost of the apparatus, they have not resulted in the amelioration of all of the disadvantages inherent in the laser scanning detection machines.

Fixed Fluorescence Detection

The fixed detection system used in DNA sequencing machines is exemplified by the automated apparatus described by Ansorge et.al. (1986), cited above; and Ansorge et.al., FRG Patent Application Nr. P36.18.605.B (1986). This apparatus consists of a laser, light from which passes through the entire width of a gel, inducing fluorescence from fluorophore-labeled DNA fragments migrating within the gel matrix, and a system for detecting and monitoring the emission of fluorescence from all four lanes.

U.S. Patent No. 4,675,095 issued to Kambara et.al. on 23 June, 1987 describes an automated DNA sequencing apparatus consisting of a laser as a source of fluorescence-inducing electromagnetic radiation, a fluorescence detection system and a computerized data storage and interpretation system. In the apparatus of the '095 patent, the light from the laser is launched horizontally into the gel from the side, i.e. in a direction which is perpendicular to the migration of the DNA bands.

5 The apparatus described in U.S. Patent No. 5,294,323 issued to Togusari et.al. on 15 March, 1994 also uses a laser, light from which is launched horizontally into the gel from the side as described in the '095 patent, as a means of fluorescence-inducing electromagnetic radiation. Fluorescence from the DNA bands is reflected by means of mirrors into a multi-component fluorescence detector. The fluorescence detector consists of an imaging lens; a bandpass filter attached to the distal end of the imaging lens; a solid state imaging device such as a photodiode, CCD sensor or MOS linear image sensor in alignment with the optical axis of the imaging lens; and a Peltier device which provides cooling to the solid state imaging device.

10 In one embodiment of the '323 patent, the fluorescence detected from each lane on the gel is condensed onto an image intensifier. The amplified image is converted to an electrical signal by a photodiode array. The electrical signal produced in this manner is processed with the aid of a computer into readable DNA sequence data.

15 The manner described by the '095 and '323 patents for launching light from the laser into the gel allows DNA sequence information to be generated using a low power laser. This therefore offers a significant cost saving in the manufacture of the machine. In addition, the use of a static laser excitation system, as alluded to above, results in a higher accuracy at faster separation speeds.

20 However, the apparatus of the '323 patent is deficient in that there is low light collection efficiency from the fluorescence of the DNA bands. In the embodiment of the '323 patent which utilizes the CCD detector, for example, this arises because there is a large disparity between the size of the gel being imaged and the size of the CCD used in the detector. The lens required to demagnify the image of the gel onto the CCD leads to a low efficiency of fluorescent light collection (the detector/lens combination "sees" a small solid angle). As a consequence of this detector design, signal

level is compromised. Due to the compromised signal level the dynamic range and sensitivity of the detector is limited. In order to overcome the limitations of the detector, more expensive scientific grade CCDs (when compared to widely used commercially available CCDs) must be utilized or more stringent approaches to noise reduction must be taken, e.g. detector cooling or lower noise CCDs.

The apparatus described in U.S. Patent No. 5,307,148 issued to Kambara et.al. on April 26, 1994 uses laser illumination from the side of the gel in the same way as the apparatus of the '095 and '323 patents. Unlike the '323 patent however, the '148 patent describes the use of multiple lasers which are placed parallel to one another and launched from the side with their beams spaced apart by at least one centimeter. In the preferred embodiment, the apparatus utilizes two lasers. The two laser beams are first spectrally dispersed, filtered and then refocused to form eight spectrally distinct line images (four from each laser line) on a two dimensional CCD detector. This arrangement allows use of multiple dye labels in one lane of the electrophoresis gel and allows for the respective signals to be recovered from the different emission and excitation spectra.

However, the apparatus of the '148 patent is deficient in a number of respects. The arrangement of lenses and detector, for example, is not an improvement over the apparatus of the '323 patent in terms of detector sensitivity. The sensitivity of the detector is not improved because the light collection angle is limited by the collection optics in that the optics utilize an image reduction two dimensional CCD detector. Furthermore, the apparatus of the '148 patent is deficient in that the information derived from the two laser lines is displaced in time because of the spatial separation of the beams; the launch conditions for the two lasers is unnecessarily complicated; and the collection optics are overly complex in addition to being inefficient.

SUMMARY OF THE INVENTION

It is an object of the present invention to provide, in a simple, cost effective manner, an apparatus for the analysis of biological molecules which is capable of high horizontal and vertical resolution. Although the discussion is presented in terms of electrophoresis performed in the vertical plane, it should be remembered that the following applies equally to electrophoresis performed in the horizontal plane. Furthermore, for reasons of clarity, and because of the importance of the application, the discussion is presented in terms of DNA sequence determination. This presentation should in no way be interpreted to limit the scope of the present invention. The present invention has equally valuable potential application to the analysis of other types of biological molecule, e.g. determination of RNA sequence data, as well as to techniques involving or related to sequence data, e.g. mapping and fingerprinting techniques. In addition, the present invention can be used with a variety of other photon emitting detection techniques in addition to fluorescent labeling.

The apparatus of the present invention achieves its objective in a simple yet elegant and cost-effective manner by the use of affordable, commonly available, mass manufactured optical components to focus the fluorescent light emitted by excited fluorophore-labeled DNA fragments onto a fluorescence detection system. Although the apparatus of the present invention is described in combination with CCD and diode/amplifier-based fluorescence detection systems, it is envisaged that it can be effectively used in combination with any design of fluorescence detection system.

As mentioned previously in the discussion of CCD and diode/amplifier-based fluorescence detection systems, increased horizontal resolution can be attained in DNA sequencing machines by combining the fluorescence detection system with higher efficiency optical systems which will focus more light onto the detector. Use of an array of gradient

index (GRIN) lenses such as the SELFOC lens array (SLA) available from NSG America, Inc., in the optical system of the automated DNA sequencing machines allows an image to be focused onto the fluorescence detector with a near unity magnification ratio. The most important advantage of utilizing such lens arrays for the detection of fluorescence in low light intensity conditions lies in their high numerical aperture which enables them to transmit a greater percentage of fluorescent light to the detector than the more traditional lenses used in this application.

Other advantages of such lens arrays lie not only in the fact that they are widely used and so affordable, but also in that their flexibility allows them to be utilized equally well with a variety of detection systems including the CCD or diode/amplifier-based detection systems.

As with all standard optics, the characteristic brightness of the SLA is given by the numerical aperture (NA). The SLA can operate in two modes - a field or line scanning mode. The NA of the line scanning mode is always higher than that of the field scanning mode. When used with the CCD-based detector system, the SLA operates in a line scanning mode. Due to the small pixel size of the CCD, e.g. 50 μm , the detector "sees" only a line. In contrast, when the SLA is used in conjunction with the diode/amplifier array, it uses the field scanning mode. This, again, is a function of pixel size because the diode has a much larger pixel size than the CCD, e.g. 3 mm, the detector thus "sees" a greater area.

GRIN lenses such as the SLA are typically composed of one or more rows of SELFOC graded-index micro lenses, each with equal dimensions and identical optical properties. The individual lenses which make up the SLA are aligned between two fiberglass-reinforced plastic plates. The interstices are filled with black silicone. The use of black silicone not only protects the individual lenses, but also prevents flare or crosstalk between the lenses. A continuous 1:1 image is

formed by overlapping the images from the adjacent lens elements in the SLA.

5 The SLA has been used as an optical scanning device in copiers, FAX machines and printers. As discussed previously, it offers significant optical advantages in its high aperture, simplified system for 1:1 imaging and high image quality with no peripheral distortion, as well as in the production of erect, real images. When its better optical properties are combined with manufacturing advantages such as linear construction, easy placement (suited to automatic component assembly), and small size and light weight - lens arrays of the SLA-type are well suited to their application in DNA sequencing machines.

10 Also anticipated in the scope of the present invention are improvements in the current generation of lens arrays. Newly developed technologies such as those based on lithography, diffusion of metal ions, heat treatment, high precision molding, binary optics and holographics will also have an impact on lens array development. Although lens arrays manufactured using some of the newer technologies suffer from more cross talk than the GRIN lens arrays, it is expected that ultimately such technologies will lead to practical devices which fall within the scope of this invention.

25 **SLA-CCD FLUORESCENCE DETECTION SYSTEMS**

A variety of approaches may be used to achieve increased horizontal resolution in systems which utilize CCD detectors. For example, a line- or area-scan camera can be incorporated into the design of the DNA sequencing machine. However, such cameras like some of the automated DNA sequencing machines described thus far, utilize an image reduction CCD, i.e. a camera lens images the object onto a CCD that is considerably smaller than the object. The increased horizontal resolution obtained from this design is offset by the low light collection efficiency of the lens - light is lost in the "demagnification" step which is required for fluorescence

detection by the CCD. Contact imaging CCDs, however, are the same size as the object and, when used with high numerical aperture lens arrays, such as the SLA, do not share the image reduction CCD's limitation of low light collection efficiency.

5 The combination of the CCD detector and SLA in a DNA sequencing machine offers a number of significant advantages over DNA sequencing systems of the prior art with regard to the overall efficiency of data collection and interpretation. The SLA allows for up to 10 times more fluorescent light to be
10 captured by the detection system. The fact that the lens array provides 1:1 imaging with high numerical aperture enables the CCD to operate with significantly increased sensitivity.

15 One advantage of the SLA-CCD detector combination, and one unexpected from a review of the prior art, is the ability of the CCD to function efficiently without the inclusion of cooling means in the apparatus. Although the SLA allows for significantly increased amounts of light to be focused on the CCD, the signal to noise ratio of the CCD remains within
20 acceptable limits without the need to provide cooling. Provision of cooling means leads to a further improvement in the signal to noise ratio. The fact that acceptable results can be obtained without the requirement for cooling affords reductions in the cost and complexity of manufacturing the DNA
25 sequencing machine.

30 As a result of the increased sensitivity imparted to the system by use of the combination of lens array and CCD-based detector, more reliable quantitative information can be obtained from the electrophoresis of DNA samples through the matrix of a gel. For example, compensation can be made for artifacts produced by suboptimal electrophoresis conditions such as globular bands, sloping bands, intralane smiling and uneven distribution of sample across lanes. In this way, reliable DNA sequence information can be obtained from
35 electrophoresis conditions which would otherwise have yielded ambiguous data.

5 However, the utility of data generated by a DNA sequencing apparatus which utilizes the SLA-CCD detector combination is not limited to the increased accuracy of the DNA sequence information obtained. For example, the better quantitation of DNA in individual bands which is obtained from the combination can be used to provide data on the efficiency of the enzyme utilized in the sequencing reaction as well as data regarding the local structure of the DNA strand being sequenced. Such information can be employed by modern data analysis algorithms to further enhance the efficiency of methods used to decipher stretches of ambiguity in the base sequence as read from the electrophoresis of labeled DNA fragments through a gel matrix. Other areas where the data generated by the system of the present invention are invaluable are those involving allele analysis and fragment mapping, detection of heterozygotes and analysis of viral mutations and populations.

10 The system therefore has numerous applications in a variety of areas including, but not limited to, paternity testing procedures, forensic medicine, clinical evaluation of disease and cancer-inducing mutations in genes, evaluation of anti-viral drug resistance-inducing mutations during treatment regimens, protein/DNA interaction analysis, and bacterial fingerprinting, in addition to de novo DNA sequencing.

20 The DNA sequencing machines using SLA-CCD fluorescence detector systems will not only be able to adapt to improvements in gel electrophoresis, but, as previously alluded to, will actually be made more efficient by their implementation. Improvements in present electrophoresis techniques such as those concerning gel composition, loading and electrophoresis conditions will, for example, lead to decreased band width. Some presently available DNA sequencing machines are limited in their vertical resolution and would therefore be unable to take advantage of such improvements. In the system of the present invention, however, it is the means of detection, and not the laser beam, which defines the detector spatial bandwidth of the system. For this reason,

the system's resolution has the potential to be increased by improvements in electrophoresis technology with the ultimate result that it will have the ability to read sequence data reliably beyond 1000 bases in an acceptable time. This capability results from not only an increased detector resolution, but also reduced residence time in the gel. Assuming that the loading band is optimally narrow this combination leads to reduced diffusion and thus reduced band width.

In the present multi-photodiode instruments, the laser beam can wander in the vertical plane within wide limits without affecting sensitivity. This advantage occurs as a result of the relatively large aperture of the emission path. However, in the case of the 1:1 imaging CCD, the CCD becomes the limiting aperture in the system (typically this is a function of the CCD pixel size which is of the order of 50 um in the vertical dimension). Thus the laser must be precisely aligned to the detector by, for example, the use of an actuated mirror at the entrance to the gel. An alignment error signal can be derived either from pixels at each end of the CCD or through diodes dedicated for this purpose. The tendency of the laser to wander is a major factor in determining whether alignment must be an ongoing process during electrophoretic separation of the labeled DNA fragments. Laser wandering can be a function of gel composition and/or the laser/dye combination. When using lasers at the red end of the spectrum, for example, an initial adjustment at the beginning of the electrophoresis separation is all that is required.

The diode lasers available in the red and NIR region of the spectrum are capable of high frequency 100% modulation which allows for simple multiwavelength excitation. Two or more laser beams of different wavelength can be launched coaxially through the gel from one or both sides. One hundred percent modulation of the lasers allows each laser beam to share the same spatial path while being separated in time. This allows for considerable simplification of detector design. Since the

laser beams are not separated in space like the detector of the '148 patent, signals are superimposable in time and emitted fluorescent light is collected efficiently and refocused approximately 1:1 through filters onto either the single or multiple line CCDs mentioned above.

Several recent technological developments in the area of laser diodes, red and near infra-red (NIR) fluorescing dyes, multicolor scanners and optical filter design allow for further increase in the performance of the detection system of the current invention.

Contact imaging CCDs for color scanning are available currently in two configurations: three line CCDs, each line with its own bandpass filter to screen out unwanted wavelengths of light; and single line CCDs, with alternating stripes of bandpass filters. CCDs of either type, with only minor modifications, e.g. matching the bandpass filters to the dyes chosen, allow multiple dye detection. Alternatively, multi-notch filters in combination with single line CCDs also allow use of more than one excitation wavelength.

Another advantage of a DNA sequencing apparatus which incorporates the SLA-CCD detection system arises from the fact that the vertical and horizontal resolution is not limiting. As a result, there are more lanes on the gel available for loading of sample and so more information can be obtained from a single gel.

DIODE/AMPLIFIER FLUORESCENCE DETECTION SYSTEMS

As discussed earlier, the ability to integrate signal amplifier and diode into a single modular structure or alternatively, manufacture a diode array assembly associated with multiple external amplifier devices, has allowed the diode/amplifier-based fluorescence detection systems to overcome some of the physical constraints which had previously limited their use in DNA sequencing machines. The more compact structure of the new diode/amplifier combinations enables the entire gel width to be covered by detectors. In

addition, the stacking height of the detector is less than 5 mm. This imparts the ability to design a DNA sequencing machine which uses non-coaxial beams capable of analyzing two or more dyes in a system where light from the lasers may be coupled through a single standard light coupling plate which minimizes the time delay between the two beams.

The lens arrays contained in DNA sequencing machines which utilize SLA-diode/amplifier detection systems usually contain approximately six rows of GRIN lenses. The exact number of rows is a function of detector pixel size (dimensions parallel to the direction of DNA migration).

As mentioned above, the SLA operates in a field scanning mode when combined with the diode/amplifier detection systems. One of the main advantages of utilizing a detection system for biological molecules such as DNA which contains an SLA in combination with a diode/amplifier detection system lies in the system's dynamic range, a product of the system's increased observation volume compared to that of the CCD-lens array combination. Unlike the apparatus containing the SLA-CCD combination, the SLA-diode/amplifier apparatus tolerates laser movement because of its relatively large field of view (as discussed before, this is a function of the pixel size, e.g. approximately 3 mm in the photodiode/amplifier compared to 50 um in the CCD).

Another advantage to the SLA-diode/amplifier combination detection systems is found in the use of wide gels with high sample capacity for electrophoresis and in instances where so-called laser "bending" occurs. Laser bending usually occurs during electrophoresis when the laser has been engaged for periods of about 2 hours. The beam will bend upwards if the laser was initially pointing up; bend downwards if it was initially pointing down; and will occur even if the laser was pointing only slightly up or down at the time that scanning was initiated. Bending cannot be corrected by adjusting the incident angle of the laser. Although bending disappears within 2 minutes of the electrophoresis being stopped, it will

reappear when the electric field is turned on again. The only way to prevent continued bending is to change the gel's position so that the laser beam can contact a new and unaffected portion of the gel.

5 As alluded to in the discussion of the SLA-CCD combination, laser beam bending has been found to be dependent on the type of gel matrix and the laser/dye system being used. For example, bending occurs most strongly when fluorescein is excited by an Argon laser (488 nm); to a lesser extent when
10 tetramethylrhodamine is excited by a He-Ne laser (543 nm); only minimally when Texas Red is excited by a yellow HeNe laser (594); and imperceptibly at 633 nm with CY5 dye. Samples which migrate through the gel close to the point of laser entry are affected to a lesser degree than those in the
15 opposite part of the gel.

The SLA-diode/amplifier combination is advantageous in counteracting the deleterious effects of laser bending in that the field of view of the detector encompasses all but large deviations of the laser beam. This advantage is limited,
20 however, to those instances, discussed above, where laser bending is problematic.

Although it has many advantages, the SLA-diode/amplifier combination is still costly and has limitations in terms of vertical and horizontal resolution. Furthermore, a DNA
25 sequencing machine containing the combination will not be able to adapt to the improvements in gel technology noted above in the discussion of the SLA-CCD combination.

Although both combinations give rise to DNA sequencing machines which are improvements over the prior art, each of
30 the two combinations of SLA (with diode/amplifier or CCD detectors) has advantages and disadvantages associated with its use. Depending on the relative importance of a number of factors, including cost, sensitivity, the degree of horizontal and vertical resolution required, as well as factors
35 associated with beam wandering (a function of laser wavelength, gel type, and dye), either combination may be more

or less preferable. The incorporation of the SLA into the design of the DNA sequencing machine is a key element enabling the various improvements.

5 **BRIEF DESCRIPTION OF THE DRAWING**

Figure 1 is a sketch showing the layout of the laser, optical, CCD detector and data collation components of the apparatus for gel electrophoresis of the present invention.

10 Figure 2(a) is a schematic diagram showing the arrangement of beam sensing pixels on the CCD element and the composition of the feedback loop system for the detection and correction of beam wandering.

15 Figure 2(b) is a schematic diagram showing the arrangement of position sensitive diodes on the CCD element and the composition of the feedback loop system for the detection and correction of beam wandering.

20 Figure 3(a) is a sketch showing the layout of the laser, optical, CCD detector and data collation components of the apparatus for gel electrophoresis of the present invention in which light from two separate laser light sources irradiate the gel electrolyte layer of the electrophoresis gel at two distinct regions.

25 Figure 3(b) is a sketch showing the layout of the laser, optical, CCD detector and data collation components of the apparatus for gel electrophoresis of the present invention in which light from three separate laser light sources are combined so that the gel electrolyte layer of the electrophoresis gel is irradiated at a single region.

30 Figure 4(a) is a schematic diagram of the arrangement of color filters on a single line CCD element.

Figure 4(b) is a schematic diagram of the arrangement of color filters on stacked CCD elements.

35 Figure 5 is a sketch showing the layout of the laser, optical, photodiode/amplifier detector and data collation components of the apparatus for gel electrophoresis of the present invention.

Figure 6(a) is a schematic diagram of the arrangement of the photodiode and amplifier components in the integrated photodiode/amplifier module detector of the present invention.

5 Figure 6(b) is a schematic diagram of the arrangement of the photodiode and amplifier components of the non-integrated photodiode/amplifier detector of the present invention.

10 Figure 7 is a sketch showing the layout of the laser, optical, photodiode/amplifier detector and data collation components of the apparatus for gel electrophoresis of the present invention in which light from two distinct laser light sources irradiate the gel electrolyte layer of the electrophoresis gel at two distinct regions.

15 Figure 8(a) is an example of the output of the embodiment of the present invention which utilizes a CCD detector and is described in Figures 1 to 3.

Figure 8(b) is an example of the output of the embodiment of the present invention which utilizes a photodiode/amplifier detector and is described in Figures 5 to 7.

20 DESCRIPTION OF PREFERRED EMBODIMENTS OF THE INVENTION

25 Preferred embodiments of the invention incorporate a number of features. The specific form of those features presented in the preferred embodiments of the invention are in accordance with its use as an apparatus for the determination of the sequence of DNA, specifically for the determination of sequence information from the separation of fluorophore-labeled DNA fragments prepared using the method of Sanger et.al.. This application has been selected because of its widespread use and importance. In other applications, other specific forms may be preferable.

30 Reference will now be made to the drawings, whereby like parts are designated by like numerals.

35 With reference to Figure 1, samples are loaded into a predetermined number of sample loading wells 10 situated at the top of a polyacrylamide gel 16 contained in an electrophoresis apparatus 12 consisting of components well

known to those skilled in the art and assembled according to standard procedures. The polyacrylamide gel is immersed at its opposite ends in an electrolyte in electrode tanks. A voltage, applied across the electrode tanks by means of a power supply, causes the samples to migrate within the gel electrolyte layer 16. The samples migrate in a downward direction through the gel electrolyte layer 16 situated between two electrophoresis plates 17', 17'' so that a plurality of parallel migration lanes 18 form. These parallel migration lanes 18 substantially correspond to the positions of the sample loading wells 10.

Light from a single laser light excitation source operating in the wavelength range 400 to 900 nm, 19 (such as a He-Ne laser operating at a wavelength of 633 nm) is focused by a condenser lens 20 and finally steered through a beam director 21 so that it is launched into the gel electrolyte layer 16 situated between two electrophoresis plates 17', 17'' at a predetermined linear irradiation region 22. When light from the single laser light excitation source 19 excites the fluorophore-labeled DNA fragments 23 migrating through the gel electrolyte layer 16 situated between two electrophoresis plates 17', 17'', fluorescent light is emitted from the fluorophore-labeled DNA fragments 23. The fluorescent light emitted from the excited fluorophore-labeled DNA fragments 23 falls on a light collection and focusing lens array 24 which is situated in a posterior position relative to the electrophoresis plates 17', 17'' and extends in a direction parallel to the linear irradiation region 22. The fluorescent light emitted from the excited fluorophore-labeled DNA fragments 23 is collected by the light collection and focusing lens array 24 and focused onto a filter arrangement 25 and then onto a CCD element 26.

The light collection and focusing lens array 24 consists of an array of gradient index lenses composed of individual SELFOC graded-index micro lenses 28 of substantially equal dimension and substantially identical optical properties. The

individual lenses 28 are aligned between two fiberglass-reinforced plastic plates 29, 30. The interstices 31 are filled with black silicone.

5 The gradient index lens array provides near unity magnification of light focused onto the CCD element 26. The CCD element 26 is divided into a plurality of photosensitive cells or pixels 32.

10 As the temperature rises, an increasing amount of dark current will flow through the CCD element 26 and thereby reduce its efficiency. In order to alleviate this problem, the CCD element 26 can be adapted to be cooled with the Peltier device 33 so that it will, at all times, be operational within a predetermined temperature range. To enhance the cooling efficiency, a heat sink 34 is included
15 with the Peltier device 33.

The fluorescent line images collected and focused onto the CCD element 26 by the light collection and focusing lens array 24 are converted to electrical signals which are then displayed on a monitor 36 and fed to a controller 35 and a
20 digital data processor 37. The digital data processor 37 monitors temporal alterations in the intensities of the fluorescent line images and feeds the results to a device such as a printer 38 which reproduces data in readable form.

25 For certain applications, it may be preferable to maintain the beam from the laser light excitation source 19 within precise limits to prevent beam wandering. As shown in Figure 2(a), this can be accomplished by including dedicated beam sensing pixels 39 or, as shown in Figure 2(b), separate position sensitive diodes 40 at opposite ends of the CCD
30 element 26. Signal from the beam sensing pixels 39 or position sensitive diodes 40 can be used to control other components well known to those skilled in the art, such as a laser beam director 41 or detector position actuators 42, in a feedback loop system in order to maintain the beam from the
35 laser light excitation source 19 within predetermined limits with respect to the detector means 26.

In other applications it may be preferable to utilize more than one laser light excitation source. Means of multiple laser light excitation are shown in Figures 3(a) and 3(b). Figure 3(a) depicts a system in which excitation is accomplished by the utilization of two separate laser light sources 19, 19'. Light from the two laser light excitation sources 19, 19' strikes the electrolyte layer 16 situated between the two electrophoresis plates 17', 17'' at two distinct, predetermined linear irradiation regions 43, 44.

Fluorescent light emitted by the excited fluorophore-labeled DNA fragments 23 is collected by a light collection and focusing lens array 24 and is focused through light filters 45, 46 and then onto two CCD elements 26, 26'.

Alternatively, as shown in Figure 3(b), light from two or more laser light excitation sources 19', 19'', 19''' can be combined in a beam combining element 47, so that the combined beam strikes the gel electrolyte layer 16 situated between two electrophoresis plates 17', 17'' at a single predetermined linear irradiation region 48.

Fluorescent light emitted by the excited fluorophore-labeled DNA fragments 23 is collected and focused by a light collection and focusing lens array 24 and is focused through a multiple notch light filter 52 and then onto a single CCD element 26.

For either apparatus depicted in Figures 3(a) or 3(b) the CCD element can be cooled by Peltier device 33 and associated heat-sink 34.

Fluorescent light emitted by the excited fluorophore-labeled DNA fragments 23 in the apparatus depicted in either Figure 3(a) or 3(b) can be detected by matching multiple CCD elements 26, 26' with specific color filters 45, 46 or by the utilization of CCD elements 26 modified by the incorporation of multicolor filters 50 deposited on the CCD element 26 by techniques well known to those skilled in the art.

In Figure 4(a) multicolor filters 50 are shown as filters 101, 102, 103 in a single line CCD element 26. Alternatively,

as shown in Figure 4(b), the CCD elements can be stacked closely together on the same substrate and single color filter 201, 202, 203 used to coat each CCD element. Depending on beam dimensions, this combination could be used in conjunction with the laser configuration of Figure 3 or Figure 7.

In another separate embodiment of this invention, shown in Figure 5, samples are loaded into a predetermined number of sample loading wells 10 situated at the top of a polyacrylamide gel 16 contained in an electrophoresis apparatus 12 consisting of components known to those skilled in the art and assembled according to standard procedures. The polyacrylamide gel 16 is immersed at its opposite ends in an electrolyte in electrode tanks. A voltage, applied across the electrode tanks by means of a power supply, causes the samples to migrate within the gel electrolyte layer 16. The samples migrate in a downward direction through the gel electrolyte layer 16 situated between two electrophoresis plates 17', 17'' so that a plurality of parallel migration lanes 18 form. These parallel migration lanes 18 substantially correspond to the positions of the sample loading wells 10.

Light from a single laser excitation source 19 operating within the wavelength range 400 to 900 nm (such as a He-Ne laser operating at a wavelength of 633 nm) is focused by a condenser lens 20 and finally steered through a beam director 21 so that it is launched into the gel electrolyte layer 16 situated between two electrophoresis plates 17', 17'' at a predetermined linear irradiation region 22. When light from the single laser light excitation source 19 excites the fluorophore-labeled DNA fragments 23 migrating through the gel electrolyte layer 16 situated between the two electrophoresis plates 17', 17'', fluorescent light is emitted from the fluorophore-labeled DNA fragments 23. The fluorescent light emitted from the excited fluorophore-labeled DNA fragments 23 falls on a light collection and focusing lens array 24 which is situated in a posterior position relative to the

electrophoresis plate 17', 17'' and extends in a direction parallel to the linear irradiation region 22. The fluorescent light emitted from the excited fluorophore-labeled DNA fragments 23 is collected by the light collection and focusing lens array 24 and focused onto a filter arrangement 25 and then onto a into a photodiode/amplifier assembly 55.

The light collection and focusing lens array 24 consists of an array of gradient index lenses composed of individual SELFOC graded-index micro lenses 28 of substantially equal dimension and substantially identical optical properties. The individual lenses 28 are aligned between two fiberglass-reinforced plastic plates 29, 30. The interstices 31 are filled with black silicone.

The gradient index lens array provides near unity magnification of light focused onto the photodiode/amplifier assembly 55.

As shown in Figures 6(a) and 6(b), the photodiode/amplifier assembly 55 can be configured in two ways. In Figure 6(a) the photodiode/amplifier assembly 55 consists of one or more rows of integrated photodiode/amplifier modules 56. The individual integrated photodiode/amplifier modules consist of a signal amplifier 58 in combination with the electronics required for signal multiplexing 59 and a diode chip 60. The individual diode chips 60 each contain a single pixel 61 of uniform size.

The photodiode/amplifier assembly 55 shown in Figure 6(b) consists of distinct amplifier and diode modules 62, 63, respectively. The diode module 63 consists of one or more rows of photodiodes 61, of uniform size.

The diode module 63 is associated with the amplifier module 62. The amplifier module 62 consists of integrating detector amplifiers 58 and signal multiplexer 59.

In certain applications, it may be preferable to utilize two or more laser light excitation sources 19 to excite the fluorophore-labeled DNA fragments 23 as they migrate through

the gel electrolyte layer 16 situated between two electrophoresis plates 17', 17''. Figure 7 shows two individual laser light excitation sources 19, 19' which strike the gel electrolyte layer 16 situated between the two electrophoresis plates 17', 17'' at two distinct, predetermined linear irradiation regions 43, 44.

Light emitted from the excited fluorophore-labeled DNA fragments 23 is collected by the light collection and focusing lens array 24 and focused through light filters 45, 46 onto two diode/amplifier assemblies 65, 66 situated so that each is able to detect the fluorescent light emitted from one of the linear irradiation regions 43, 44. The filter arrangement 50 has been previously described in Figures 4(a) and 4(b).

Sample output from a detector of the CCD type described in Figures 1 to 3 is shown in Figure 8(a). Sample output from a detector of the multiple diode type described in Figures 5 to 7 is shown in Figure 8(b).

While the invention has been described in terms of certain preferred embodiments, it should be understood that other and further modifications may be made without diminishing the scope of the invention which is set forth in the following claims.

CLAIMS**WHAT IS CLAIMED IS:**

1. An improved apparatus for analysis of biological molecules of the type having a gel matrix means for separating labeled biological molecules in electrophoretic pathways by application of an electrical potential means to said gel matrix means, and in which a light generating means excites said labeled biological molecules while they migrate in said gel matrix means, and in which collection and focusing means collect and focus output signals emitted by said excited biological molecules, and in which a detection means and storage means detect, store and analyze said signals collected from said excitation of labeled biological molecules, characterized in that:

a collection and focusing means comprises a substantially unity magnification lens array for collecting output light signals emitted by said labeled biological molecules and focusing said output signals along a linear area extending transversely across said gel matrix means such that respective pathways of electrophoretic migration can be detected independently of one another.

2. The apparatus of claim 1 wherein said electrical potential means comprises two electrodes coupled to spatially separated portions of said matrix means in a vertical plane.

3. The apparatus of claim 1 wherein said electrical potential means comprises two electrodes coupled to spatially separated portions of said matrix means in a horizontal plane.

4. The apparatus of claim 1 wherein said light generating means comprises laser means.

5. The apparatus of claim 1 wherein said light generating means comprises at least one laser means capable of 100% modulation for coaxially projecting light of different wavelengths onto said gel matrix means.

6. The apparatus of claim 1 wherein said light generating means comprises at least one laser operating in the wavelength range 400-900 nm.

7. The apparatus of claim 1 wherein light from said light generating means is projected horizontally onto said gel matrix means in a direction which is substantially perpendicular to said electrophoretic pathways of said labeled biological molecules.

5

8. The apparatus of claim 1 wherein said output from said light generating means is projected in a direction substantially perpendicular to said electrophoretic pathways of said labeled biological molecules.

10

9. The apparatus of claim 1 wherein labeled biological molecules are excited at a predetermined position along said electrophoretic pathways, said labeled biological molecules emitting a detectable output in response thereto.

15

10. The apparatus of claim 1 wherein said lens array of said collection and focusing means comprises at least one row of graded-index micro-lenses or focusing means of similar function.

20

11. The apparatus of claim 1 wherein said lens array of said collection and focusing means comprises a predetermined number of lenses forming an array of sufficient length to detect output signal from opposite ends of a linear irradiation region of said gel matrix means used for separation of said labeled biological molecules.

25

12. The apparatus of claim 1 wherein said detection means comprises filter means in combination with a CCD sensing means, said CCD sensing means containing sufficient cells to provide output signals from a linear irradiation region of said gel matrix detectable as a predetermined number of pixels.

30

13. The apparatus of claim 12 wherein said CCD sensing means is operational at ambient temperature.

14. The apparatus of claim 12 wherein said CCD sensing means further comprises supplementary cooling means.

35

15. The apparatus of claim 1 wherein said detector means is composed of a filter means in combination with at least one

row of diode/amplifier modules, said diodes containing pixels of substantially uniform size.

16. The apparatus of claim 1 wherein said detector means is composed of a filter means in combination with at least one row of diode modules connected to external amplifier modules, said diode modules containing pixels of substantially uniform size.

17. The apparatus of claim 16 wherein said rows of diode/amplifier modules are of a length to detect output signals from opposite ends of a linear irradiation region of said gel matrix means.

18. The apparatus of claim 1 wherein signals from said sensing means are coupled to digital data processor means.

19. The apparatus of claim 1 wherein said label incorporated into said biological molecules comprises at least one fluorescent dye.

20. The apparatus of claim 1 wherein said label incorporated into said biological molecule is a phosphor.

21. The apparatus of claim 1 wherein said biological molecule is selected from the group consisting of bacteria, nucleic acid and protein.

22. The apparatus of claim 1 wherein said means of separation is selected from the group consisting of capillary means, slab means and channel means.

23. The apparatus of claim 1 wherein a predetermined number of individual lenses located at opposite ends of said lens array in said detecting means are provided for sensing light from said light generating means, said individual lenses forming part of a feedback system to align said light generating means within defined vertical parameters.

24. An improved apparatus for sequencing nucleic acid of the type having a gel matrix means for separating labeled molecules of nucleic acid in electrophoretic pathways by application of an electrical potential means to said gel matrix means, and in which a light generating means excites said labeled molecules of nucleic acid while they migrate in

said gel matrix means, and in which collection and focusing means collect and focus output signals emitted by said excited molecules of nucleic acid, and in which a detection, storing and displaying means detect, store and display said output signal from said excitation of labeled molecules of nucleic acid, characterized in that said apparatus further comprises:

means for projecting an output from said light generating means in a direction substantially perpendicular to direction of said migration of labeled molecules of nucleic acid; and

a means for collecting and focusing signal emitted from said labeled molecules of nucleic acid onto at least one detecting means, said collecting and focusing means comprising a lens array of at least one row of graded-index micro lenses or focusing means of similar function, said collecting and focusing means providing substantially unity magnification of signal.

25. The apparatus of claim 24 wherein said nucleic acid is selected from the group consisting of DNA and RNA.

26. The apparatus of claim 24 wherein said label comprises at least one fluorescent dye.

27. The apparatus of claim 24 wherein said label is a phosphor.

28. The apparatus of claim 24 wherein said light generating means comprises laser means.

29. The apparatus of claim 24 wherein said light generating means comprises at least one laser means capable of 100% modulation for coaxially projecting light of different wavelengths onto said gel matrix means.

30. The apparatus of claim 24 wherein said light generating means comprises at least one laser operating in the wavelength range 400-900 nm.

31. The apparatus of claim 24 wherein different wavelengths of said output from said light generating means are projected coaxially onto said gel matrix means in a direction which is substantially perpendicular to said electrophoretic pathways of said labeled molecules of nucleic acid.

32. The apparatus of claim 24 wherein light from at least one said light generating means is projected horizontally onto said gel matrix means in a direction which is substantially perpendicular to said electrophoretic pathways of said labeled molecules of nucleic acid.

33. An improved method for sequencing labeled molecules of nucleic acid by means of apparatus of the type having a gel matrix means for separating labeled molecules of nucleic acid in substantially parallel electrophoretic pathways by application of an electrical potential means to said gel matrix means, and in which a light generating means excites said labeled molecules of nucleic acid while they migrate in electrophoretic pathways in said gel matrix means, and in which collection and focusing means collect and focus output signals emitted by said excited molecules of nucleic acid, and in which a detection, storing and displaying means detect, store and display said output signal from said excitation of labeled molecules of nucleic acid, characterized in that the method further comprises:

projecting an output from said light generating means in a direction substantially perpendicular to the direction of said migration of said labeled molecules of nucleic acid; and

exciting said labeled molecules of nucleic acid with said light generating means while said labeled molecules of nucleic acid migrate in a predetermined direction in said electrophoretic pathways; and

detecting along a predetermined linear area transverse to said gel matrix means, light signals emitted from said labeled molecules of nucleic acid as a result of excitation by said light generating means, such that signals representative of pixels forming respective pathways of electrophoretic migration can be detected independently of one another.

34. The method of claim 33 wherein said labeled molecules of nucleic acid are selected from the group consisting of DNA and RNA.

35. The method of claim 33 wherein said label incorporated into said molecules of nucleic acid comprises at least one fluorescent dye.

36. The method of claim 33 wherein said label incorporated
5 into said molecules of nucleic acid is a phosphor.

37. The method of claim 33 wherein said light generating means comprises laser means.

38. The method of claim 33 wherein said light generating means comprises at least one laser capable of 100% modulation
10 such that laser beams of different wavelengths are projected coaxially into said gel matrix means in a direction which is substantially perpendicular to electrophoretic migration pathways of said labeled molecules of nucleic acid.

39. The method of claim 33 wherein light from said light
15 generating means is projected horizontally into said gel matrix means in a direction which is substantially perpendicular to electrophoretic migration pathways of said labeled molecules of nucleic acid.

40. The method of claim 33 wherein said labeled molecules
20 of nucleic acid are excited at a predetermined position along said electrophoretic migration pathway such that said labeled molecules of nucleic acid emit an output signal.

41. The method of claim 33 wherein light signals emitted
25 by said labeled molecules of nucleic acid are collected in a lens array and imaged onto a CCD detector, said lens array providing substantially unity magnification of said light signals.

42. The method of claim 33 wherein light signals emitted
30 by said labeled molecules of nucleic acid are collected in a lens array and imaged onto an amplifier/diode detector, said lens array providing substantially unity magnification of said light signals.

Fig. 1

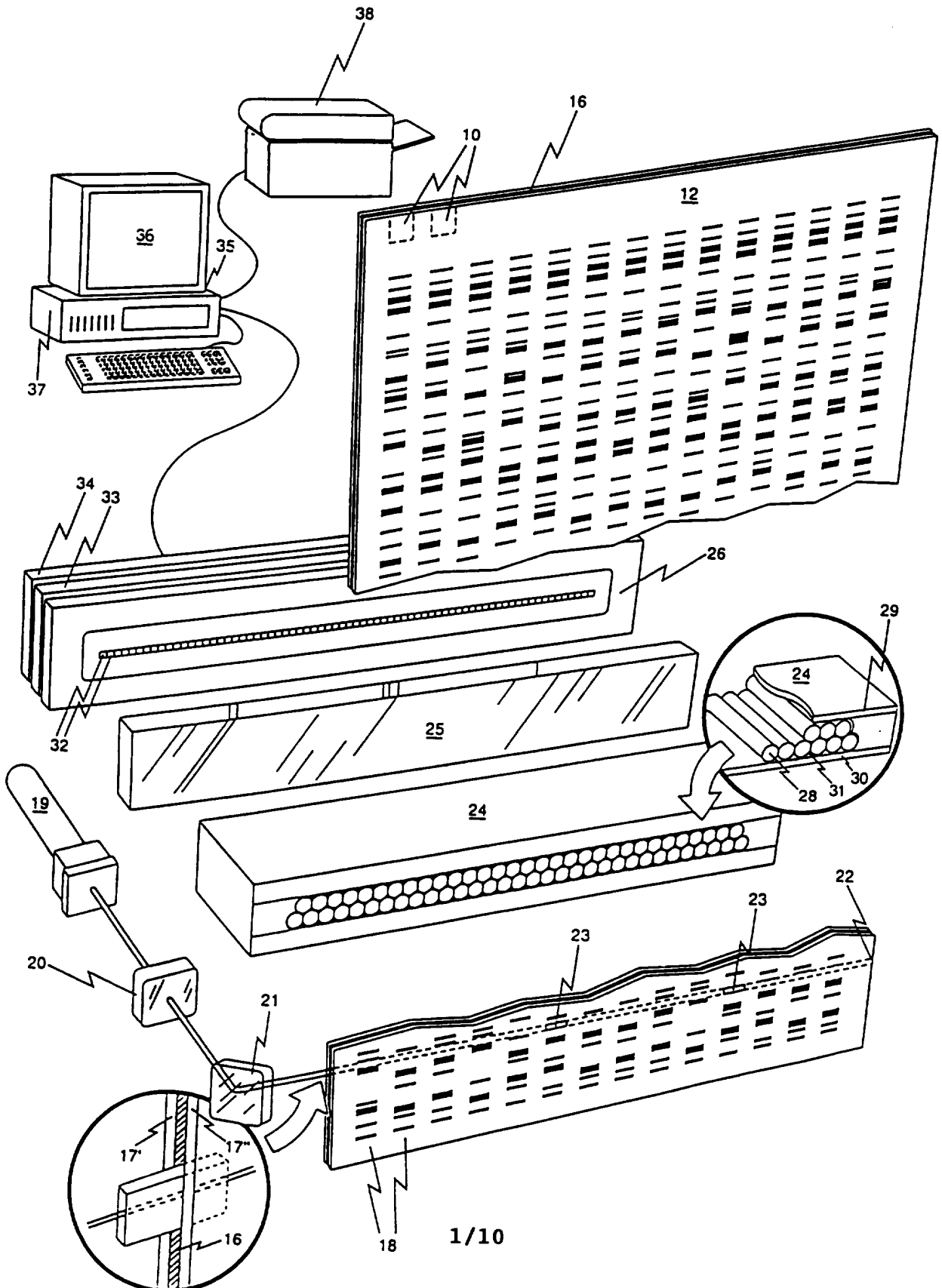

Fig. 2a

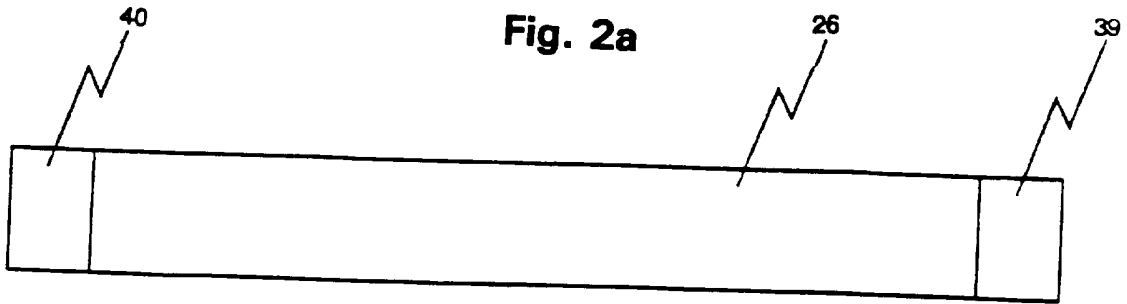

Fig. 2b

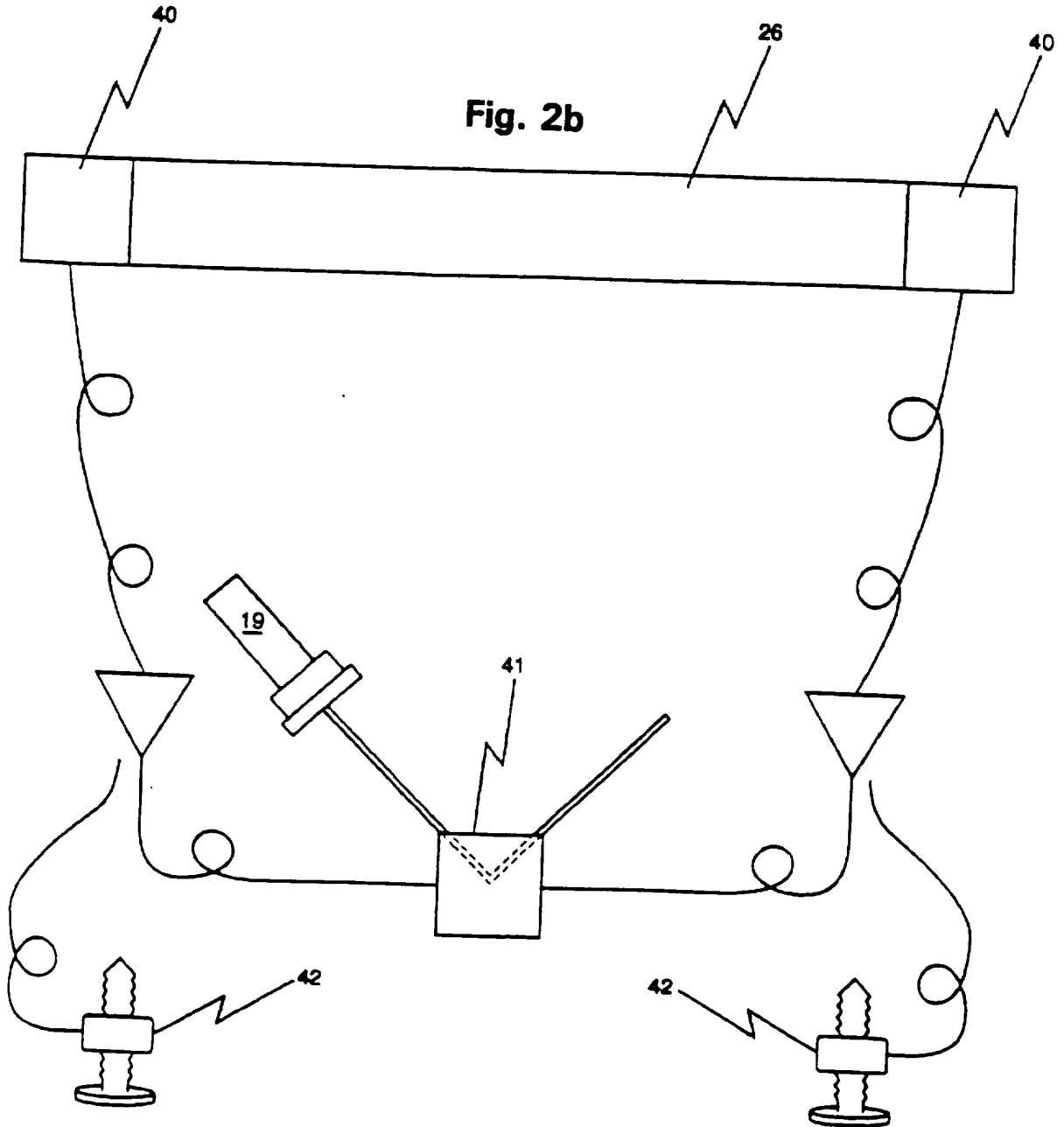

Fig. 3a

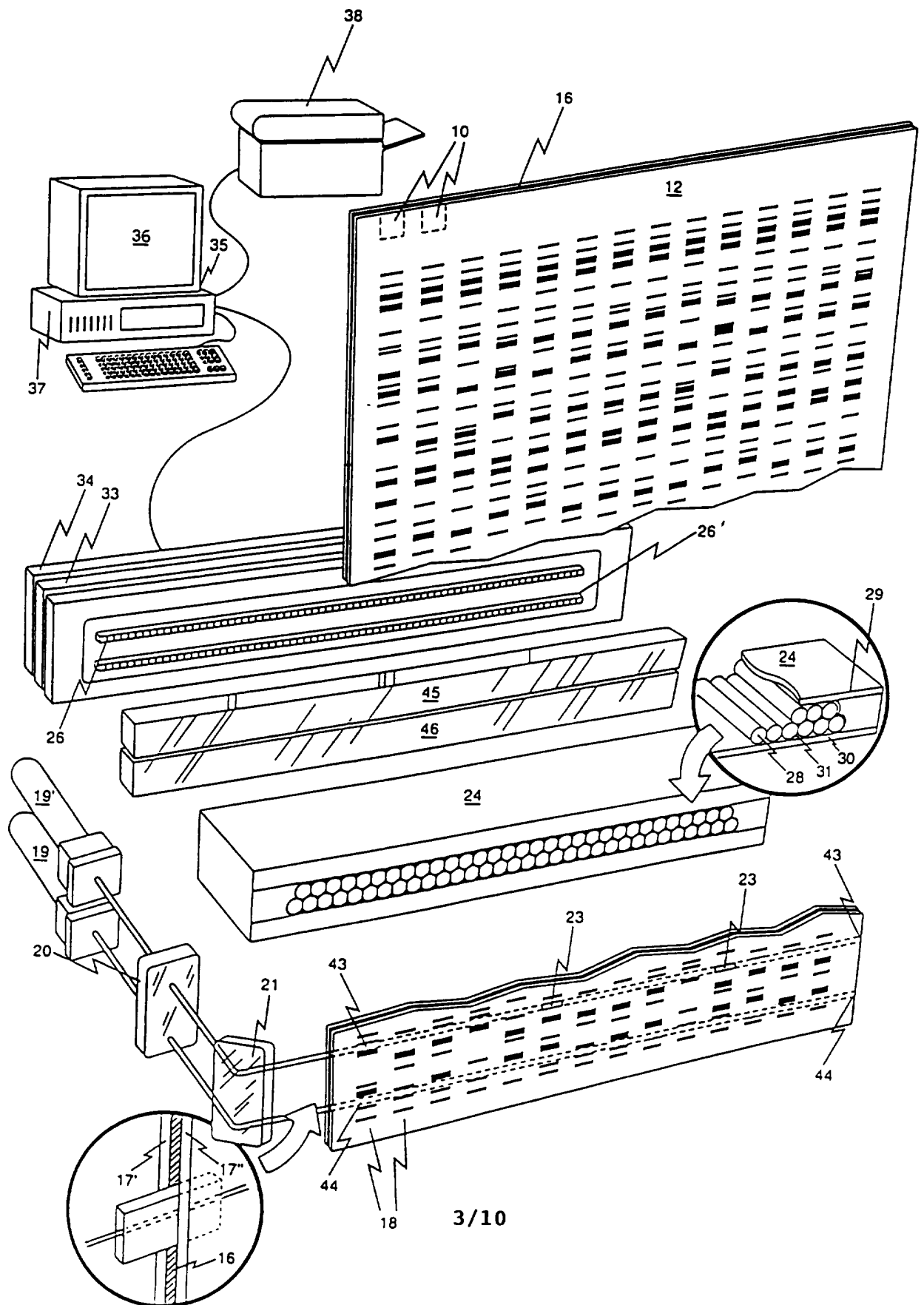

Fig. 3b

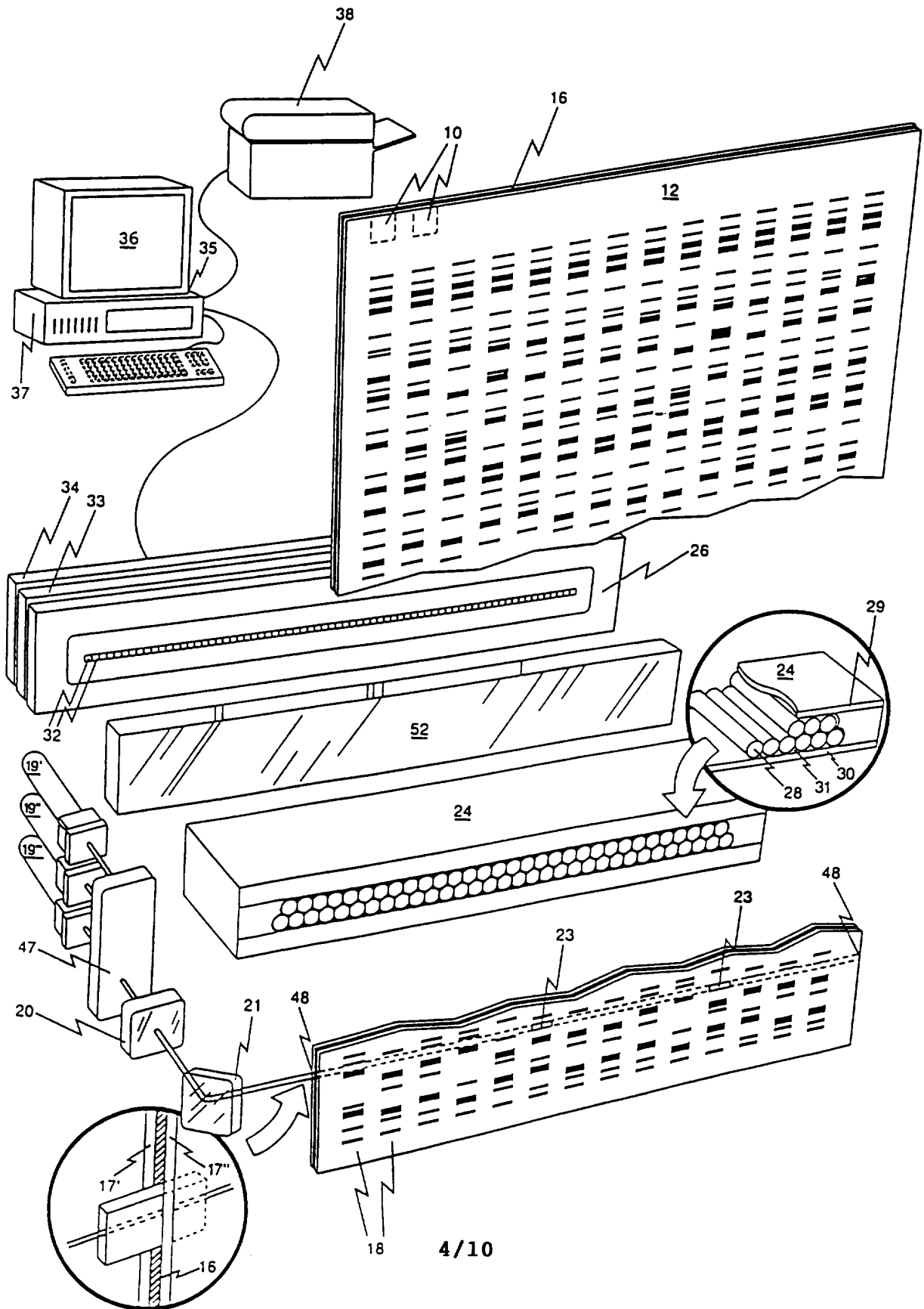

Fig. 4a

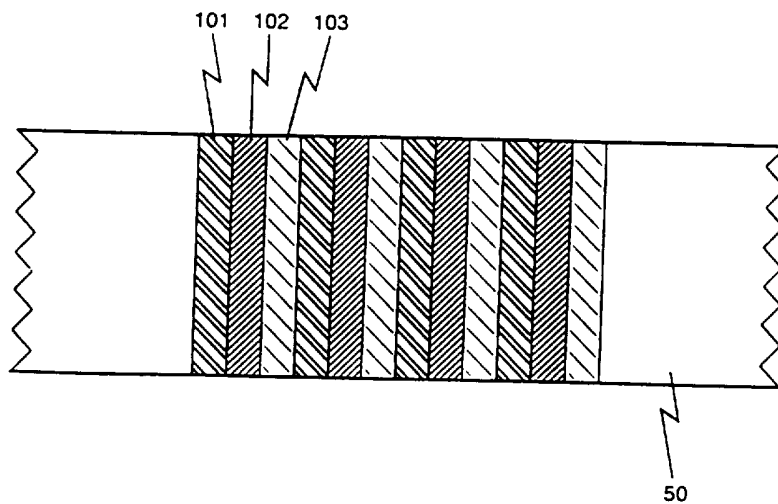

Fig. 4b

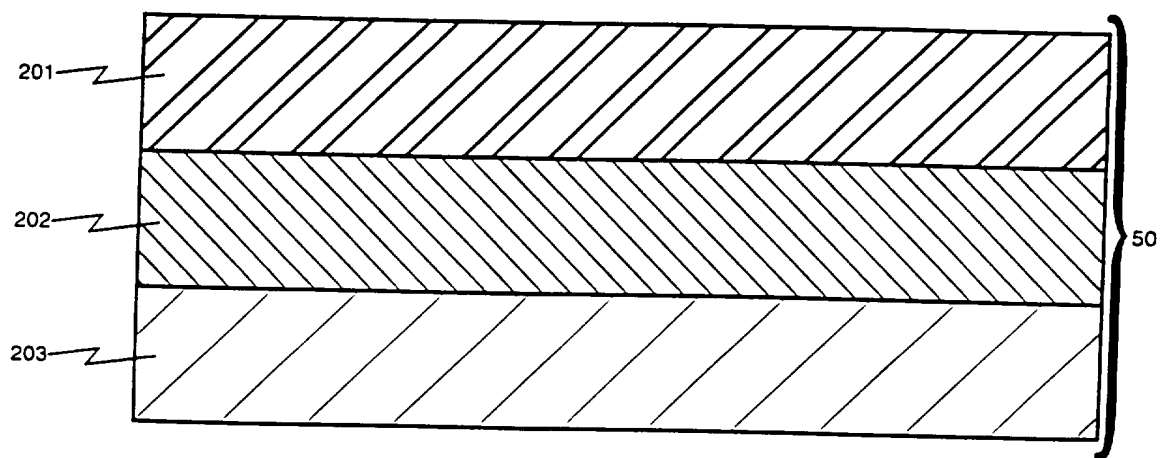

Fig. 5

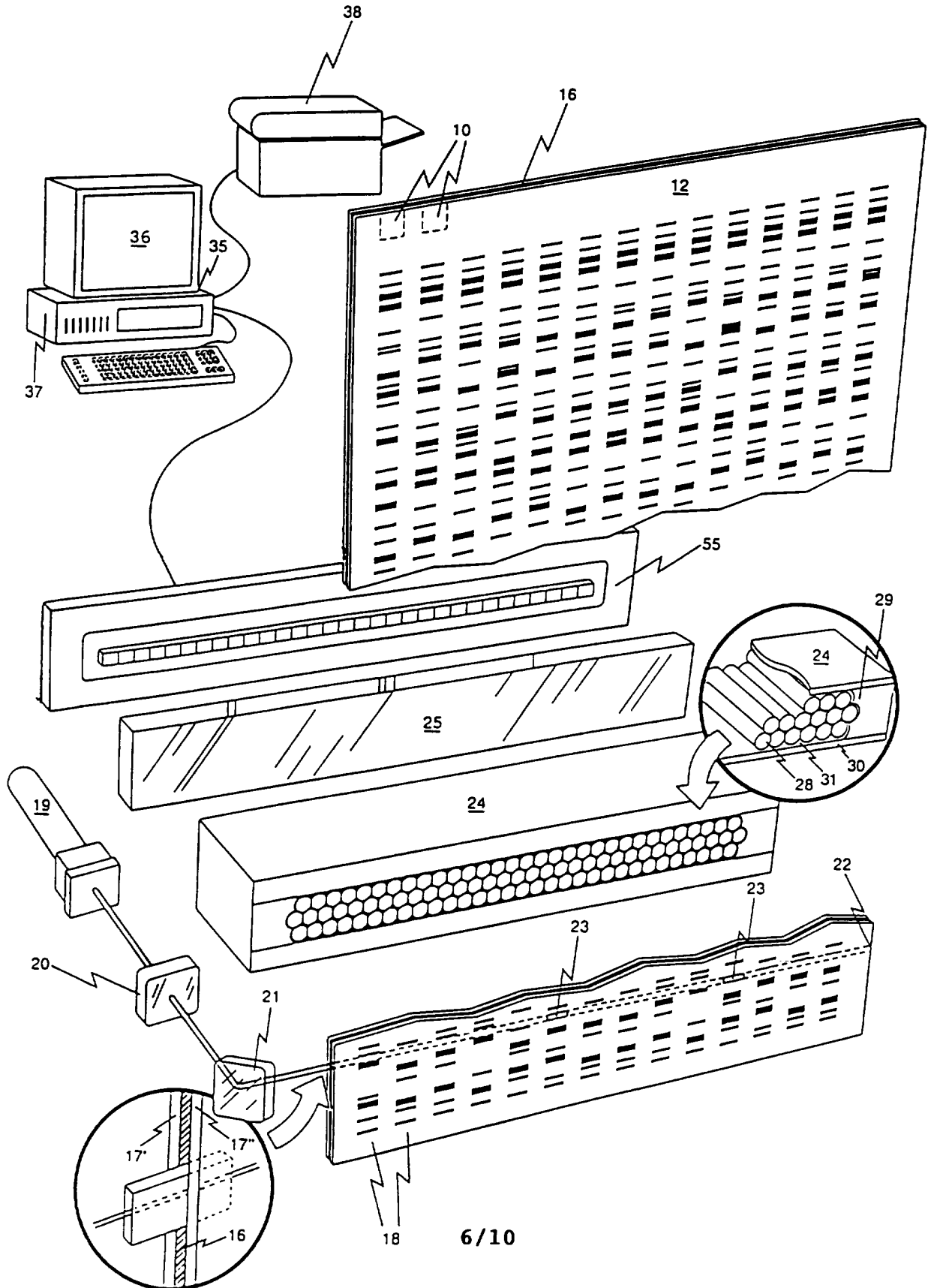

Fig. 6a

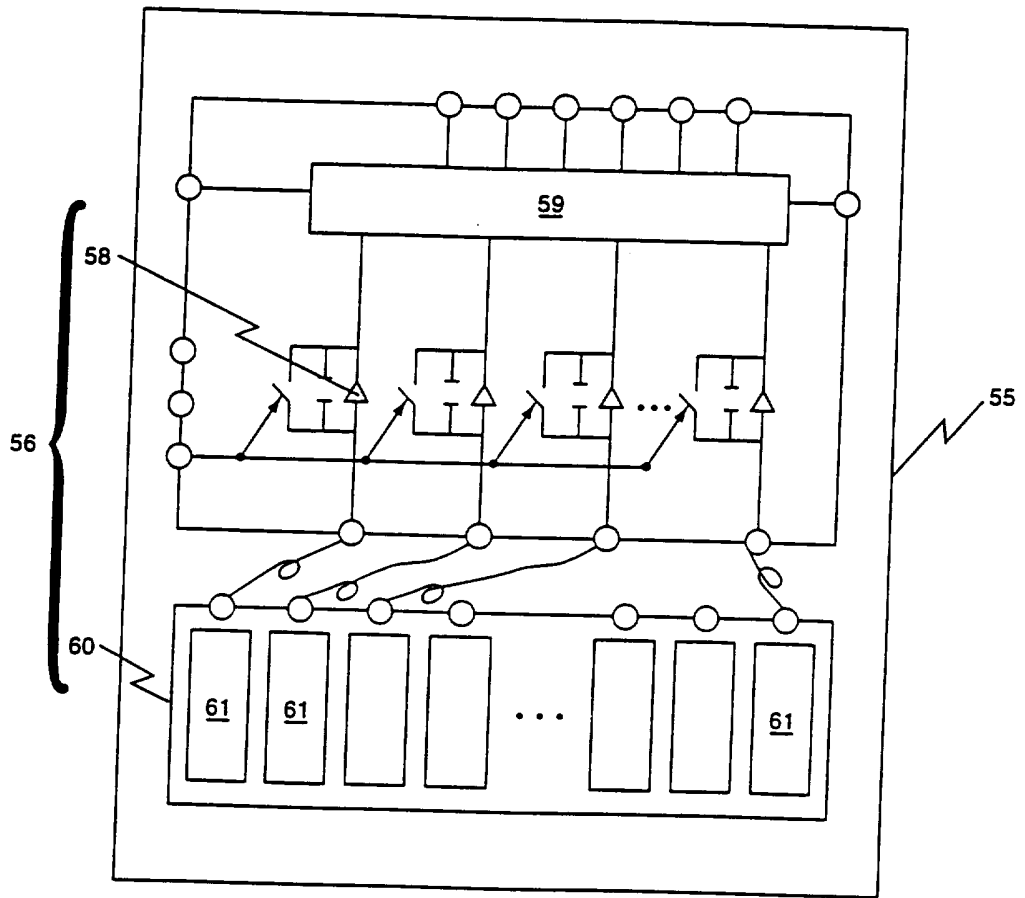

Fig. 6b

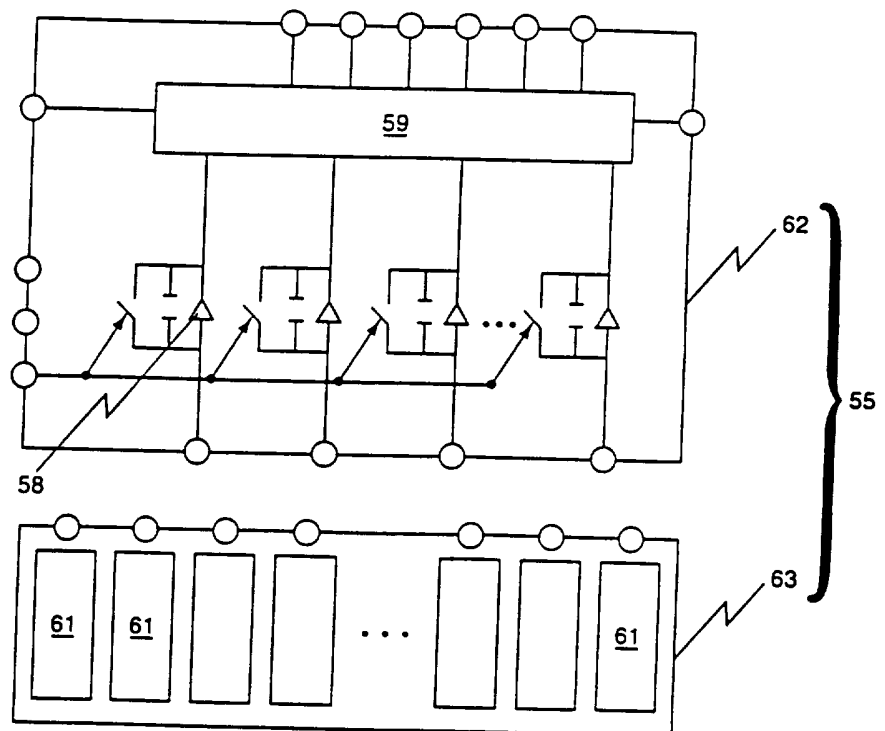

Fig. 7

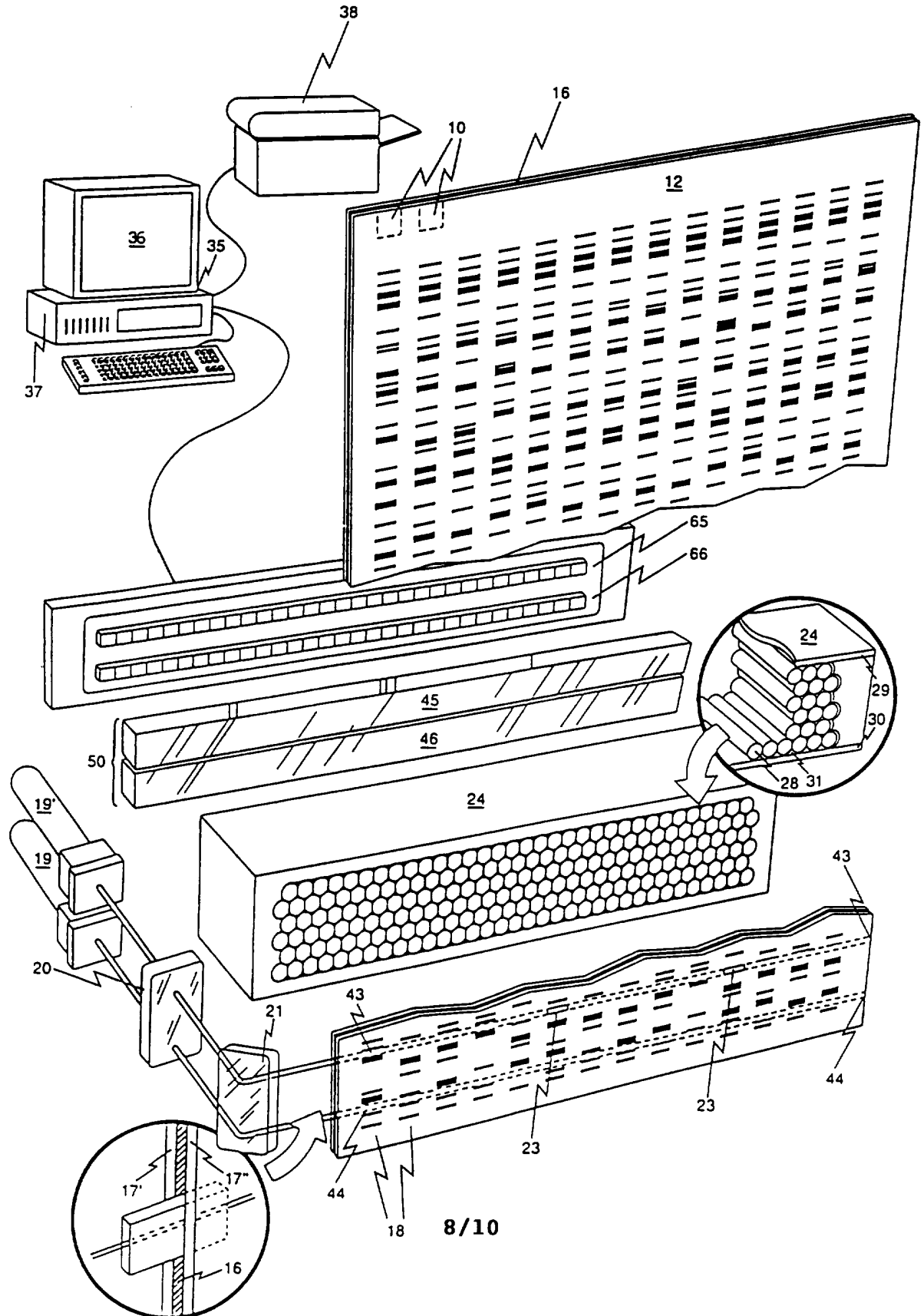

Fig. 8a

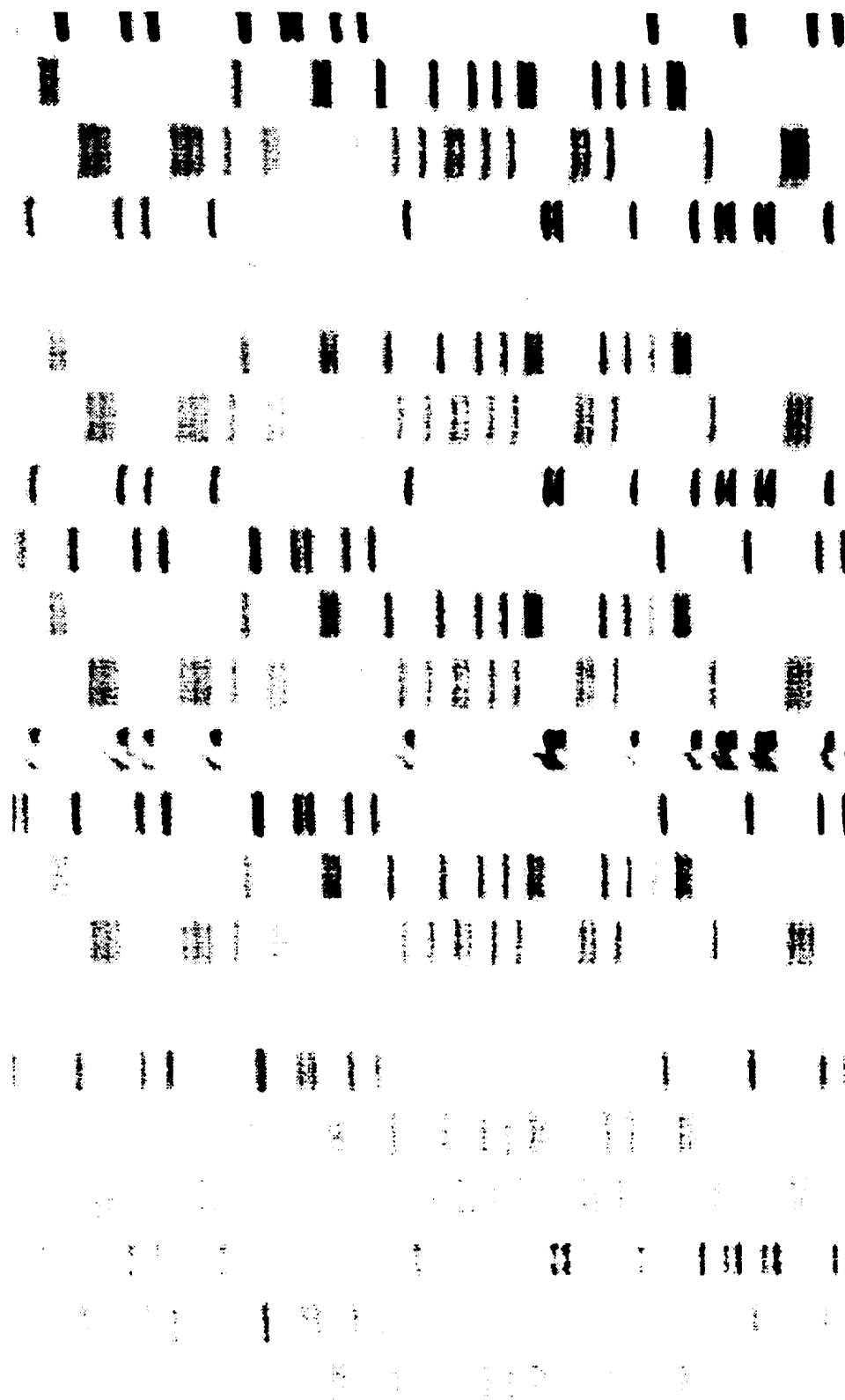
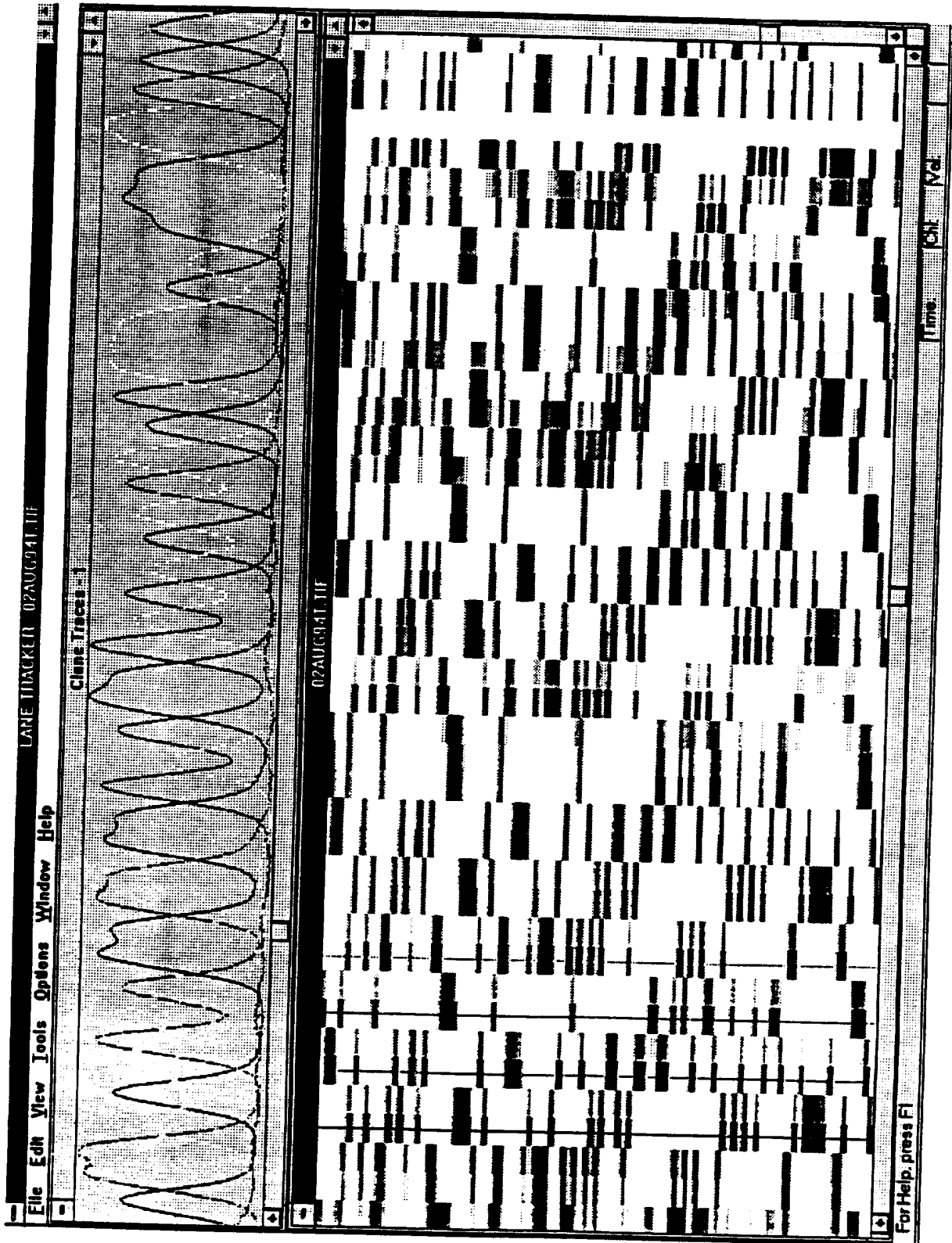

Fig. 8b



INTERNATIONAL SEARCH REPORT

International application No.

PCT/US96/01613

A. CLASSIFICATION OF SUBJECT MATTER

IPC(6) :GOIN 27/26, 27/447

US CL :204/461,612

According to International Patent Classification (IPC) or to both national classification and IPC

B. FIELDS SEARCHED

Minimum documentation searched (classification system followed by classification symbols)

U.S. : 204/461,612

Documentation searched other than minimum documentation to the extent that such documents are included in the fields searched

Electronic data base consulted during the international search (name of data base and, where practicable, search terms used)

C. DOCUMENTS CONSIDERED TO BE RELEVANT

Category*	Citation of document, with indication, where appropriate, of the relevant passages	Relevant to claim No.
E	EP,A, 0645622 (Hitachi Electronics Engineering Co., LTD) 29 March 1995, see entire document.	1-42
X ---- Y	US,A, 4,971,677 (Kambara et al) 20 November 1990. See entire document.	33-35,37, 39, & 40 ----- 36,38
X	WO,A, 87/07719 (Europa Sches Laboratorium For Molekularbiologie) 17 December 1987. See entire document.	33-40

Further documents are listed in the continuation of Box C. See patent family annex.

* Special categories of cited documents:	*T	later document published after the international filing date or priority date and not in conflict with the application but cited to understand the principle or theory underlying the invention
A document defining the general state of the art which is not considered to be of particular relevance	*X*	document of particular relevance; the claimed invention cannot be considered novel or cannot be considered to involve an inventive step when the document is taken alone
E earlier document published on or after the international filing date	*Y*	document of particular relevance; the claimed invention cannot be considered to involve an inventive step when the document is combined with one or more other such documents, such combination being obvious to a person skilled in the art
L document which may throw doubts on priority claim(s) or which is cited to establish the publication date of another citation or other special reason (as specified)	*&*	document member of the same patent family
O document referring to an oral disclosure, use, exhibition or other means		
P document published prior to the international filing date but later than the priority date claimed		

Date of the actual completion of the international search

08 APRIL 1996

Date of mailing of the international search report

15 MAY 1996

Name and mailing address of the ISA/US Commissioner of Patents and Trademarks
Box PCT
Washington, D.C. 20231

Facsimile No. (703) 305-3230

Authorized officer

KATHRYN GORGOS

Telephone No. (703) 308-3328