



- (51) **International Patent Classification:**
B41J 2/175 (2006.01) *B41J 2/135* (2006.01)
- (21) **International Application Number:**
PCT/US2016/015211
- (22) **International Filing Date:**
27 January 2016 (27.01.2016)
- (25) **Filing Language:** English
- (26) **Publication Language:** English
- (71) **Applicant:** HEWLETT-PACKARD DEVELOPMENT COMPANY, L.P. [US/US]; Hewlett-Packard Company, 11445 Compaq Center Drive W., Houston, Texas 77070 (US).
- (72) **Inventors:** SING, Sam; Columbia Tech Center, 1115 SE 164th Ave, Columbia Center, Suite 210, Vancouver, Washington 98683 (US). BINGHAM, Jeffrey G; Columbia Tech Center, 1115 SE 164th Ave, Columbia Center, Suite 210, Vancouver, Washington 98683 (US). ROMAN, Justin M; Columbia Tech Center, 1115 SE 164th Ave., Columbia Center, Suite 210, Vancouver, Washington 98683 (US).
- (74) **Agents:** GARDINER, Austin et al.; HP Inc., 3390 E. Harmony Rd., Mail Stop 35, Fort Collins, Colorado 80528 (US).

- (81) **Designated States** (unless otherwise indicated, for every kind of national protection available): AE, AG, AL, AM, AO, AT, AU, AZ, BA, BB, BG, BH, BN, BR, BW, BY, BZ, CA, CH, CL, CN, CO, CR, CU, CZ, DE, DK, DM, DO, DZ, EC, EE, EG, ES, FI, GB, GD, GE, GH, GM, GT, HN, HR, HU, ID, IL, IN, IR, IS, JP, KE, KG, KN, KP, KR, KZ, LA, LC, LK, LR, LS, LU, LY, MA, MD, ME, MG, MK, MN, MW, MX, MY, MZ, NA, NG, NI, NO, NZ, OM, PA, PE, PG, PH, PL, PT, QA, RO, RS, RU, RW, SA, SC, SD, SE, SG, SK, SL, SM, ST, SV, SY, TH, TJ, TM, TN, TR, TT, TZ, UA, UG, US, UZ, VC, VN, ZA, ZM, ZW.
- (84) **Designated States** (unless otherwise indicated, for every kind of regional protection available): ARIPO (BW, GH, GM, KE, LR, LS, MW, MZ, NA, RW, SD, SL, ST, SZ, TZ, UG, ZM, ZW), Eurasian (AM, AZ, BY, KG, KZ, RU, TJ, TM), European (AL, AT, BE, BG, CH, CY, CZ, DE, DK, EE, ES, FI, FR, GB, GR, HR, HU, IE, IS, IT, LT, LU, LV, MC, MK, MT, NL, NO, PL, PT, RO, RS, SE, SI, SK, SM, TR), OAPI (BF, BJ, CF, CG, CI, CM, GA, GN, GQ, GW, KM, ML, MR, NE, SN, TD, TG).

Published:
— with international search report (Art. 21(3))

(54) **Title:** FLUID SUPPLY ASSEMBLY

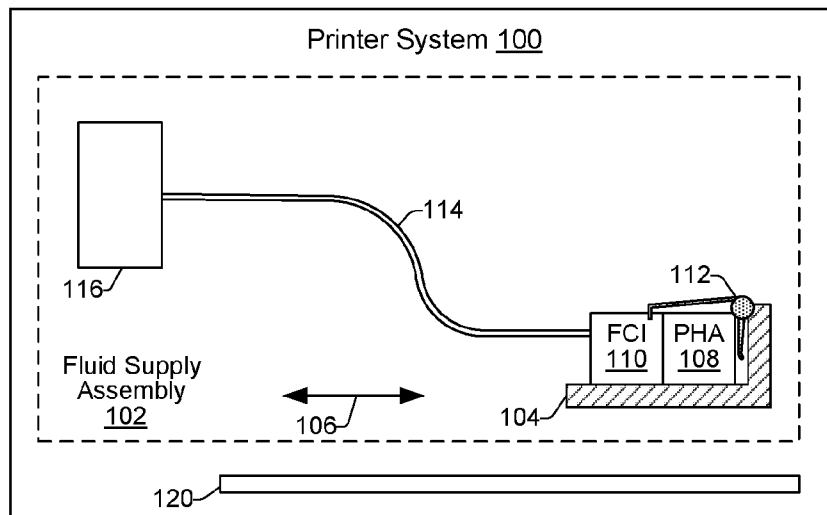

FIG. 1

(57) **Abstract:** In an example implementation, a fluid supply assembly includes a printhead assembly and a fluid conduit interconnect to connect to a fluid conduit to communicate printing fluid from an off-axis printing fluid supply through the fluid conduit interconnect to the printhead assembly. The fluid supply assembly includes a carriage with a dual attachment mechanism to simultaneously attach the printhead assembly to the fluid conduit interconnect and to the carriage by a single user action.

WO 2017/131677 A1

FLUID SUPPLY ASSEMBLY

BACKGROUND

[0001] Printing systems are a type of fluid dispensing system that can be used to print images and/or text onto a print medium or print target. Some printing systems can include a moveable carriage to which a printhead assembly is attached. The printhead assembly can deliver printing fluid to a print medium or print target during operation of the printing system. Printing fluid can be supplied to a printhead assembly by an on-axis fluid supply that travels along with the printhead assembly on the moveable carriage, or by an off-axis, stationary fluid supply that supplies fluid to the printhead assembly through a tube or other fluid conduit.

BRIEF DESCRIPTION OF THE DRAWINGS

[0002] Examples will now be described with reference to the accompanying drawings, in which:

[0003] FIG. 1 shows a block diagram of an example printing system in which examples of a fluid supply assembly may be implemented;

[0004] FIG. 2 shows an example fluid supply assembly in which a fluid pump is incorporated to control the flow of printing fluid;

[0005] FIG. 3 shows an example fluid supply assembly in which multiple off-axis printing fluid supplies are fluidically coupled to a printhead assembly through a fluid conduit;

[0006] FIG. 4a shows a side view of an example arrangement that includes a printing system carriage, a printhead assembly, and a fluid conduit interconnect in an unattached condition;

[0007] FIG. 4b shows a side view of an example arrangement of a carriage, a printhead assembly, and a fluid conduit interconnect in a mounted but unattached condition;

[0008] FIG. 4c shows a side view of an example arrangement of a carriage, a printhead assembly, and a fluid conduit interconnect in a mounted and attached condition;

[0009] FIG. 5a shows a perspective view of an example arrangement that includes a printing system carriage, a printhead assembly, and a fluid conduit interconnect in an unattached condition;

[0010] FIG. 5b shows a perspective view of an example arrangement of a carriage, a printhead assembly, and a fluid conduit interconnect in a mounted but unattached condition;

[0011] FIG. 5c shows a perspective view of an example arrangement of a carriage, a printhead assembly, and a fluid conduit interconnect in a mounted and attached condition;

[0012] FIG. 6 shows a flow diagram of an example process of forming an example arrangement of components of a fluid supply assembly within a printing system.

[0013] Throughout the drawings, identical reference numbers designate similar, but not necessarily identical, elements.

DETAILED DESCRIPTION

[0014] Printing systems, such as various inkjet printing systems, can include on-axis and off-axis printing fluid supply systems to facilitate the printing of text and/or images onto print media. Some example printing systems can include both on-axis and off-axis fluid supplies, while other example systems can include either on-axis or off-axis fluid supplies. An on-axis printing fluid supply system includes one or multiple printing fluid supplies that are installed on or integrated within a printhead assembly. A printing fluid supply can include a container that holds printing fluid that is to be delivered to the printhead assembly. A printing fluid can include various types of printing fluids, such as different colored inks (e.g., cyan, magenta, yellow, black ink), or other types of printing fluid such as finishing fluids, fusing agents, and so on. Use of the term “ink” herein is intended to generally include various types of printing fluids.

[0015] A print medium can include paper, a transparency foil, or any other medium onto which printing fluid can be deposited to form an image and/or text. More generally, a print target can refer to either a two-dimensional (2D) print medium or a three-dimensional (3D) structure on which 3D printing can be performed. Accordingly, although reference is made herein to a “print medium,” it is noted that techniques and/or mechanisms presented throughout this disclosure can also be used with a 3D print target such as a bed of print material, for example. Thus, in different examples, a “printing system” may refer to a 2D printing system or a 3D printing system.

[0016] A printhead assembly can include one or multiple printing fluid ejectors (e.g., printheads) to eject printing fluid received from the one or multiple

printing fluid supplies onto a print medium during operation of the printing system. The printhead assembly can be attached to a moveable carriage of the printing system. During operation of the printing system, the moveable carriage of the printing system can move back and forth with respect to the print medium as printing fluid is deposited onto the print medium. With an on-axis fluid printing supply system, the printing fluid supply or supplies installed on or within the printhead assembly move with the carriage.

[0017] An off-axis printing supply system includes one or multiple printing fluid supplies that are separated from the printhead assembly. An off-axis printing fluid supply can be attached to another part of the printing system that is remote from the printhead assembly, or it can be attached outside of and away from the printing system. Thus, an off-axis fluid supply remains stationary with respect to the printhead assembly and carriage during operation of the printing system while the printhead assembly and carriage are moved back and forth to print onto a print medium. A print fluid conduit can be used to communicate printing fluid between each respective printing fluid supply and printing fluid ejector within the printhead assembly. A print fluid conduit can include, for example, one or multiple flexible tubes or other types of fluid communication structures.

[0018] In some example printing systems, different carriage designs are provided for respective on-axis and off-axis printing fluid supply systems. While an example printing system may have a carriage designed to accommodate an on-axis printing fluid supply system, customers often desire to have an off-axis fluid supply because it provides a larger volume of ink than is available from an

on-axis fluid supply. However, a carriage designed for an off-axis printing fluid supply system may be different from a carriage designed for an on-axis printing fluid supply system, since the carriage for the off-axis printing fluid supply system will accommodate fluid conduits (e.g. tubes) from the off-axis printing fluid supplies. Having to reconfigure a carriage designed for an on-axis printing fluid supply system to operate with an off-axis printing fluid supply system can add cost and time delay to the development of printing systems.

[0019] Accordingly, examples presented herein of a fluid supply assembly in a printing system provide access to an off-axis printing fluid supply using a carriage designed for use with an on-axis fluid supply. The fluid supply assembly includes a printhead assembly (PHA) and a fluid conduit interconnect to supply printing fluid from an off-axis supply to the PHA. The fluid conduit interconnect can be connected to a fluid conduit or fluid conduits to provide/communicate printing fluid from the off-axis printing fluid supply through the fluid conduit interconnect to the printhead assembly. Connection of the fluid conduit to the fluid conduit interconnect instead of directly to the printhead assembly enables the printhead assembly to be more easily removed from the printing system for service or replacement.

[0020] The printhead assembly and fluid conduit interconnect are both removably attachable to the printing system carriage by a dual attachment mechanism. The dual attachment mechanism is operable by a user to simultaneously attach the printhead assembly and fluid conduit interconnect to one another and to the carriage in a single action or motion. The dual attachment mechanism includes a moveable member such as a lever that can be actuated

by a user to attach or detach both the printhead assembly and fluid conduit interconnect. Thus, instead of having different mechanisms to separately attach the printhead assembly to the carriage and the fluid conduit interconnect to the printhead assembly, a single mechanism is provided to enable easy attachment and release of both the printhead assembly and fluid conduit interconnect, which facilitates customer removal and servicing or replacement of the printhead assembly.

[0021] In an example implementation, a fluid supply assembly includes a printhead assembly and a fluid conduit interconnect to connect to a fluid conduit to communicate printing fluid from an off-axis printing fluid supply through the fluid conduit interconnect to the printhead assembly. The fluid supply assembly also includes a printing system carriage with a dual attachment mechanism to simultaneously attach the printhead assembly to the fluid conduit interconnect and to the carriage by a single user action.

[0022] In another example implementation, a printing system includes an off-axis printing fluid supply, a printhead assembly, and a fluid conduit interconnect to provide printing fluid to the printhead assembly through a fluid conduit from the off-axis printing fluid supply. The printing system also includes a carriage having an attachment mechanism moveable between a locked and unlocked position, where the locked position is to simultaneously secure the printhead assembly to the carriage and the fluid conduit interconnect, and the unlocked position is to simultaneously release the printhead assembly from the carriage and the fluid conduit interconnect.

[0023] In another example implementation, a method includes providing a printhead assembly and a fluid conduit interconnect. The printhead assembly and fluid conduit interconnect are both removably attachable to a carriage of a printing system by a single latching mechanism of the carriage. The fluid conduit interconnect is connectable to a fluid conduit to communicate printing fluid from an off-axis printing fluid supply through the fluid conduit interconnect to the printhead assembly.

[0024] FIG. 1 shows a block diagram of an example printing system 100 in which examples of a fluid supply assembly 102 may be implemented. As shown in FIG. 1, an example fluid supply assembly 102 includes a moveable carriage 104. The carriage 104 can be slidably mounted onto a printing system shaft (not shown) and translated back and forth along the shaft as indicated by the directional arrow 106 in response to communications and/or control signals from a printing system controller (not shown). The carriage 104 is able to receive a printhead assembly (PHA) 108 and a fluid conduit interconnect (FCI) 110 that can both be removably attached to the carriage 104 by a single, dual attachment mechanism 112.

[0025] The fluid conduit interconnect 110 can be connected to a printing fluid conduit 114 which in turn can be connected to an off-axis printing fluid supply 116. The fluid conduit interconnect 110 enables printing fluid from the off-axis printing fluid supply 116 to flow to the printhead assembly (PHA) 108 through the fluid conduit 114 and the fluid conduit interconnect 110. In some examples, the printing fluid can flow from the fluid supply 116 to the PHA 108 under the force of gravity. In some examples, the printing system 100 can include a pump

to facilitate and/or cause the flow of printing fluid from the off-axis printing fluid supply 116 to the PHA 108. In some examples, the printing system 100 can include multiple off-axis printing fluid supplies 116 that are fluidically coupled to the PHA 108 through multiple fluid conduits 114 and the fluid conduit interconnect 110.

[0026] FIG. 2 shows an example fluid supply assembly 102 in which a fluid pump 118 (illustrated as fluid pump 118a and fluid pump 118b) is incorporated to control the flow of printing fluid from the off-axis printing fluid supply 112 to the PHA 108. A fluid pump 118 can be activated and controlled, for example, by a controller (not shown) of the printing system 100. In different implementations, a fluid pump 118 may be positioned in different locations within the fluid supply assembly 102. For example, as shown in FIG. 2, in one implementation a fluid pump 118a can be positioned in-line with the fluid conduit 114. In an alternate implementation, a fluid pump 118b (illustrated in dashed lines) can be positioned at the off-axis fluid supply 116. A fluid pump 118 can be any suitable type of pump to cause fluid to flow from the off-axis fluid supply 116 through the fluid conduit 114 and fluid conduit interconnect 110 to the printhead assembly 108. Suitable pumps may include, for example, a fluid pump, a pneumatic pump, a pneumatic driven fluid pump, and so on.

[0027] FIG. 3 shows an example fluid supply assembly 102 in which multiple off-axis printing fluid supplies 116 are fluidically coupled to the PHA 108 through a fluid conduit 114 and fluid conduit interconnect 110. In examples such as shown in FIG. 3, the fluid conduit 114 can comprise flexible ribbon tubing that includes multiple tubes or fluid paths for interconnecting the printing fluid supplies

116 to the fluid conduit interconnect 110. The fluid conduit/tubing 114 can be made of various materials such as nylon, polyurethane, polyethylene, polypropylene, poly-vinyl chloride, synthetic rubber, natural rubber, polymer, plastic, Teflon, metal, and combinations thereof. The printing fluid supplies 116 can contain various printing fluids, such as different colored inks, finishing fluids, fusing agents, and so on. Although not specifically illustrated in FIG. 3, in some examples the multiple off-axis fluid supplies 116 can be connected to a fluid pump such as the fluid pump 118 shown and discussed with regard to FIG. 2. Such a pump can be connected to the fluid supplies 116 through pressure pipes, for example, and can be activated in a selective manner by a controller (not shown) to pressurize the fluid supplies 116 to cause fluid from a particular supply 116 to flow through a particular tube or fluid pathway to the fluid conduit interconnect 110 and PHA 108.

[0028] Referring to FIGs. 1 - 3, a printing fluid supply 116 can be said to be an "off-axis" printing fluid supply 116 because it is located away from the printing system carriage 104 and remains in a stationary position within the printing system 100 during operation of the printing system 100. In some examples, an off-axis printing fluid supply 116 may be located outside of and away from the printing system 100. Conversely, the PHA 108 and fluid conduit interconnect 110 can be said to be an "on-axis" because of their attachability to the carriage 104, which enables the PHA 108 and fluid conduit interconnect 110 to move with the carriage 104 as it translates in a back and forth direction as indicated by the directional arrow 106.

[0029] During operation of the printing system 100, as the printhead assembly (PHA) 108 and fluid conduit interconnect 110 translate in a back and forth direction 106 with the carriage 104, the PHA 108 can receive printing fluid via the fluid conduit interconnect 110 and can eject printing fluid from one or multiple printing fluid ejectors onto a print target or print medium 120 to generate text and/or images in response to communications and/or control signals from the printing system controller (not shown). In some example implementations, the carriage 104 can be a stationary carriage that extends across a width of a print medium 120. In such examples, a printhead assembly 108 attached to a stationary carriage 104 may include enough printing fluid ejectors to extend across the width of the print medium 120 along the stationary carriage. In addition, the print medium 120 may be moveable relative to the stationary carriage 104. A print medium 120 or print target can include, for example, suitable cut-sheet or roll-fed media such as paper, card stock, transparencies, fabric, canvas, polyester, and so on. In some examples, as noted above, a print target can also refer to a 3D structure or 3D bed of print material for use in a 3D printing system.

[0030] The ability to provide increased volumes of printing fluid to the PHA 108 from an off-axis printing fluid supply 116 through a printing fluid conduit 114 and fluid conduit interconnect 110 enables the use of a single carriage design across various printing systems. The versatility of using off-axis printing fluid supplies helps extend the applicability of such printing systems to a wider range of printing applications, for example, from small, home or personal printing applications, to larger industrial or commercial printing applications that consume

more printing fluid. In various printing applications, the ability to remove the PHA 108, and then to service or replace the PHA 108, can be a desirable feature that enables consumers to quickly and efficiently service printing systems while reducing printing downtime. Accordingly, as shown in FIGs. 1 - 5, additional features of an example fluid supply assembly 102 in an example printing system 100 include a dual attachment or latching mechanism 112 to facilitate a quick attachment and detachment of the printhead assembly 108 from the printing system 100.

[0031] FIG.s 4 and 5 illustrate a general process of mounting and attaching a fluid conduit interconnect 110 and printhead assembly (PHA) 108 to one another and to a printing system carriage 104. FIG. 4a shows a side view of a basic block diagram representation of an example arrangement that includes a printing system carriage 104, a PHA 108, and a fluid conduit interconnect 110 in an unattached condition, where the PHA 108 and fluid conduit interconnect 110 are not yet mounted or attached to one another or to the carriage 104. FIG. 5a shows a perspective view of the example arrangement of FIG. 4a that includes additional details of the printing system carriage 104, the PHA 108, and the fluid conduit interconnect 110, in the unattached condition. In both FIGs. 4a and 5a, the fluid conduit interconnect 110 and PHA 108 are aligned with one another and with the carriage 104, as indicated by dashed direction arrows, in preparation for being mounted and attached to one another.

[0032] FIG. 4b shows a side view of an example arrangement of the carriage 104, the PHA 108, and the fluid conduit interconnect 110, in which the PHA 108 and fluid conduit interconnect 110 are mounted to one another and to

the carriage 104, but are not yet attached to one another or to the carriage 104. FIG. 5b shows a perspective view with additional details of the example arrangement of FIG. 4b in which the carriage 104, the PHA 108, and the fluid conduit interconnect 110 are mounted to one another but not yet attached to one another.

[0033] FIG. 4c shows a side view of an example arrangement of the carriage 104, the PHA 108, and the fluid conduit interconnect 110, in which the PHA 108, fluid conduit interconnect 110, and carriage 104 are mounted to one another and attached to one another with the single, dual attachment mechanism 112. FIG. 5c shows a perspective view with additional details of the example arrangement of FIG. 4c in which the PHA 108, fluid conduit interconnect 110, and carriage 104 are mounted to one another and attached to one another with the single, dual attachment mechanism 112.

[0034] Referring generally to FIGs. 4 and 5, a dual attachment mechanism 112 can comprise a dual latching mechanism 112 that includes a moveable lever 122 (or other type of moveable member) that can be actuated by a user between an unlocked position (e.g., the position shown in FIGs. 4b and 5b) and a locked position (e.g., the position shown in FIGs. 4c and 5c). In some examples, as shown in FIGs. 5a and 5b, the dual latching mechanism 112 can include a rotatable latch spindle 124 with latch openings 126 for receiving respective engagement members 128 of the printhead assembly (PHA) 108. In some implementations, the engagement members 128 can be in the form of protrusions 128 (e.g. horns) that can be received into the latch openings 126 of the latch spindle 124 upon user actuation of the moveable lever 122, as indicated by

circular direction arrows 130 (FIGs. 4b and 5b). User actuation of the moveable lever 122 rotates the rotatable latch spindle 124 in the direction 130 and puts the dual latching mechanism 112 into the locked position which attaches or secures the PHA 108 to the carriage 104.

[0035] In addition to latch openings 126 to receive PHA engagement members 128 for securing the PHA 108 to the carriage 104, the dual latching mechanism 112 includes latch arms 132 integrated with the rotatable latch spindle 124 to latch onto and secure the fluid conduit interconnect 110 to the PHA 108 and carriage 104. The latch arms 132 are positioned toward each end of the rotatable latch spindle 124 and include hook features 134 to attach to or hook onto engagement members 136 emanating from the fluid conduit interconnect 110. The engagement members 136 of the fluid conduit interconnect 110 can include, for example, engagement pins 136 that facilitate a secure connection with the hook features 134 of the latch arms 132 upon user actuation of the moveable lever 122, as indicated by circular direction arrows 130. User actuation of the moveable lever 122 rotates the rotatable latch spindle 124 in the direction 130 and puts the dual latching mechanism 112 into the locked position which attaches or secures the fluid conduit interconnect 110 to the PHA 108 and to the carriage 104. Thus, the moveable member 122 of the dual attachment/latching mechanism 112 can be actuated by a user in a single action to simultaneously attach the printhead assembly 108 to the fluid interconnect 110 and to the carriage 104.

[0036] Although a specific attachment/latching mechanism 112 is shown in FIGs. 1 - 5 for engaging the engagement members 128 and 136 of the PHA 108

and the fluid conduit interconnect 110, respectively, it is noted that in other examples, other types of attachment mechanisms for engaging and attaching the PHA 108 and fluid conduit interconnect 110 to one another and to the carriage 104 can be used.

[0037] As shown in FIG. 5a, the printhead assembly 108 can include alignment grooves 138 to align with alignment ribs (not shown) of the fluid conduit interconnect 110. The alignment ribs can be brought into engagement with the alignment grooves 138 to align fluid connecting elements 140 on the printhead assembly 108 with respective fluid connecting elements 142 on the fluid conduit interconnect 110. In other examples, other types of alignment elements can be provided on the fluid conduit interconnect 110 and printhead assembly 108 to align the fluid connecting elements 140 on the printhead assembly 108 with respective fluid connecting elements 142 on the fluid conduit interconnect 110.

[0038] In some examples, the fluid connecting elements 140 and 142 can each include a passageway and a cooperative fluid transfer mechanism associated with the passageway that enables fluid to flow from the fluid conduit interconnect 110 to the PHA 108. In some examples, the fluid transfer mechanism can include a needle/septum interface where a hollow needle in a passageway of the fluid connecting element 140, for example, can engage with a respective septum of the corresponding fluid connecting element 142. In other examples, a hollow needle can be provided in the fluid connecting element 142, and a septum can be provided in the fluid connecting element 140. Although four fluid connecting elements 140/142 are depicted in the described examples, it is

noted that in other examples, a different number of fluid connecting elements can be provided.

[0039] As shown in FIGs., 5a, 5b, and 5c, the carriage 104 includes a printing system shaft receptacle 144 that can be mounted onto a shaft (not shown) of the printing system 100 to allow the carriage 104 to be moveable along the shaft during operation of the printing system 100.

[0040] FIG. 6 is a flow diagram of an example process 600 of forming an example arrangement of components of a fluid supply assembly within a printing system.

[0041] The process 600 provides (602) a printhead assembly 108 and a fluid conduit interconnect 110 that are both removably attachable to a carriage 104 of a printing system 100 by a single latching mechanism 112 of the carriage 104. The fluid conduit interconnect 110 is connectable to a fluid conduit 114 to communicate printing fluid from an off-axis printing fluid supply 116 through the fluid conduit interconnect 110 to the printhead assembly 108.

[0042] The process 600 also provides (604) alignment elements 138 to align fluid connecting elements 142 of the fluid conduit interconnect 110 with fluid connecting elements 140 of the printhead assembly 108, as the fluid conduit interconnect 110 and printhead assembly 108 are attached to the carriage 104.

CLAIMS

What is claimed is:

1. A fluid supply assembly comprising:
 - a printhead assembly;
 - a fluid conduit interconnect to connect to a fluid conduit to communicate printing fluid from an off-axis printing fluid supply through the fluid conduit interconnect to the printhead assembly; and,
 - a printing system carriage comprising a dual attachment mechanism to simultaneously attach the printhead assembly to the fluid conduit interconnect and to the carriage by a single user action.

2. A fluid supply assembly as in claim 1, wherein the printhead assembly and the fluid conduit interconnect comprise, respectively, first and second engagement elements to attach to the dual attachment mechanism.

3. A fluid supply assembly as in claim 2, wherein the dual attachment mechanism comprises:
 - a rotatable latch spindle having latch openings to receive the first engagement elements of the printhead assembly; and,
 - latch arms to hook onto the second engagement elements, one latch arm positioned toward each end of the rotatable latch spindle.

4. A fluid supply assembly as in claim 3, wherein the dual attachment mechanism comprises a lever, and the single user action comprises movement of the lever to rotate the rotatable latch spindle to cause the latch openings to receive the first engagement elements and the latch arms to hook onto the second engagement elements.

5. A fluid supply assembly as in claim 3, wherein the first engagement elements comprise protrusions emanating from the printhead assembly and oriented to enter the latch openings upon rotation of the rotatable latch spindle.

6. A fluid supply assembly as in claim 3, wherein the second engagement elements comprise pins emanating from the fluid conduit interconnect onto which the latch arms hook upon rotation of the rotatable latch spindle.

7. A fluid supply assembly as in claim 1, wherein the printhead assembly comprises an alignment element to align the printhead assembly with the fluid conduit interconnect as a fluid connecting element of the printhead assembly is brought into engagement with a fluid connecting element of the fluid conduit interconnect.

8. A fluid supply assembly as in claim 7, wherein the fluid connecting element of the printhead assembly and the fluid conduit interconnect comprises a needle/septum fluid transfer mechanism.

9. A fluid supply assembly as in claim 1, wherein the fluid conduit comprises flexible ribbon tubing having multiple fluid paths for interconnecting multiple off-axis fluid supplies through the fluid conduit interconnect to the printhead assembly.

10. A fluid supply assembly as in claim 1, further comprising a fluid pump to cause fluid to flow from the off-axis fluid supply through the fluid conduit interconnect to the printhead assembly.

11. A printing system comprising:
an off-axis printing fluid supply;
a printhead assembly;
a fluid conduit interconnect to provide printing fluid to the printhead assembly through a fluid conduit from the off-axis printing fluid supply; and,
a carriage comprising an attachment mechanism moveable between a locked and unlocked position, the locked position to simultaneously secure the printhead assembly to the carriage and the fluid conduit interconnect, the unlocked position to simultaneously release the printhead assembly from the carriage and the fluid conduit interconnect.

12. A printing system as in claim 11, wherein the printhead assembly and fluid conduit interconnect comprise engagement mechanisms to engage the attachment mechanism upon user actuation of the attachment mechanism.

13. A printing system as in claim 11, wherein the printhead assembly and fluid conduit interconnect comprise corresponding fluid transfer mechanisms to enable transfer of printing fluid when the attachment mechanism is in the locked position.

14. A method comprising:

providing a printhead assembly and a fluid conduit interconnect, both removably attachable to a carriage of a printing system by a single latching mechanism of the carriage;

wherein the fluid conduit interconnect is connectable to a fluid conduit to communicate printing fluid from an off-axis printing fluid supply through the fluid conduit interconnect to the printhead assembly.

15. The method of claim 14, further comprising:

providing alignment elements to align fluid connecting elements of the fluid conduit interconnect with fluid connecting elements of the printhead assembly, as the fluid conduit interconnect and printhead assembly are attached to the carriage.

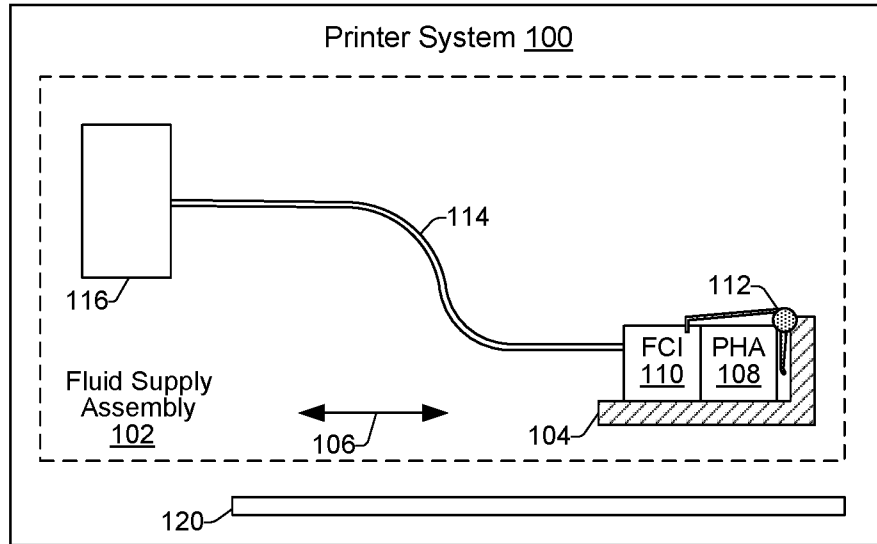

FIG. 1

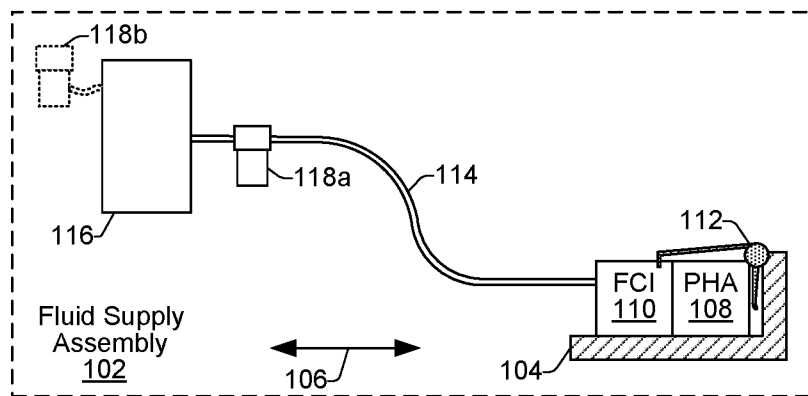

FIG. 2

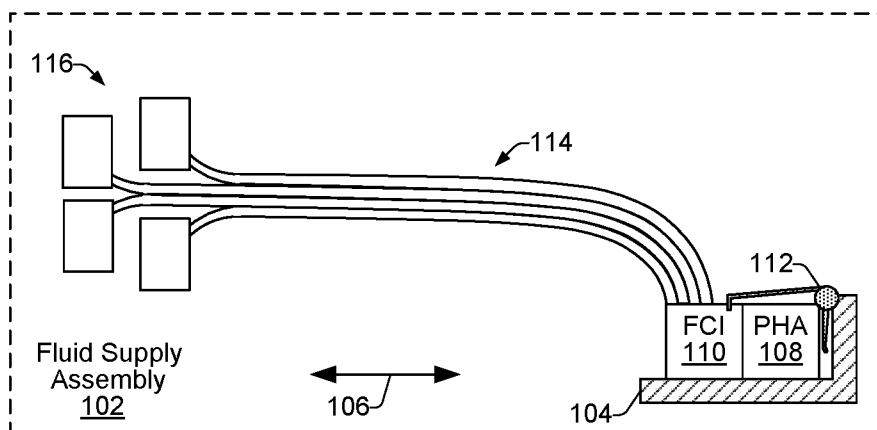

FIG. 3

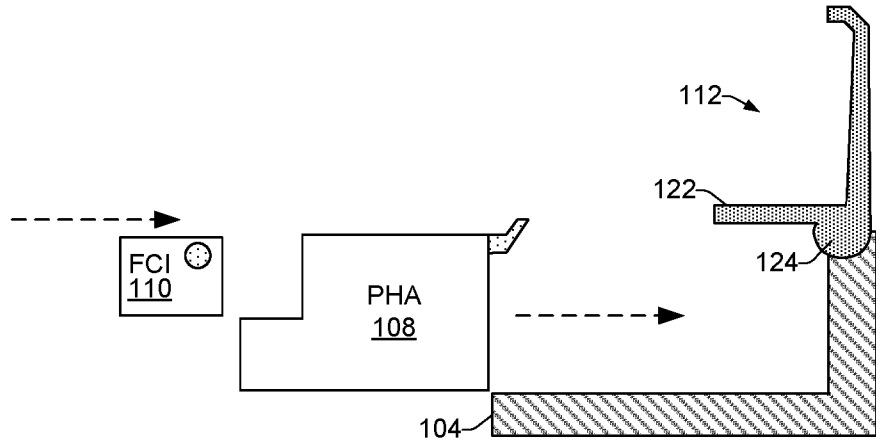

FIG. 4a

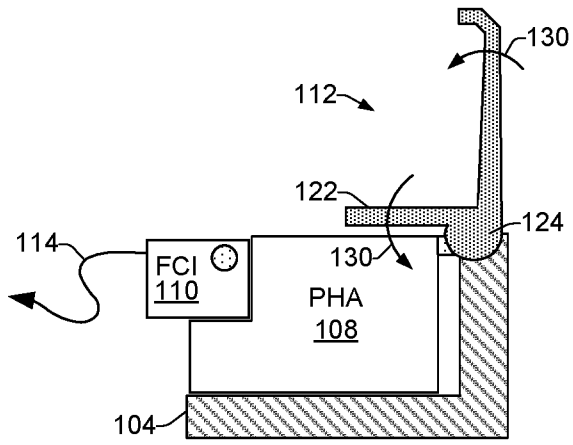

FIG. 4b

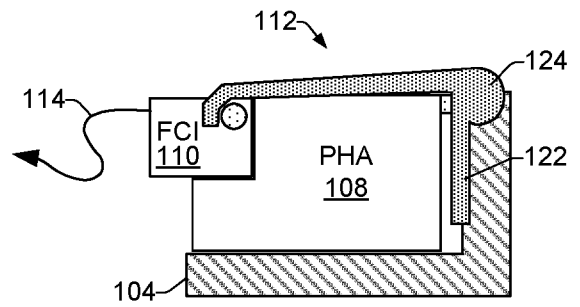

FIG. 4c

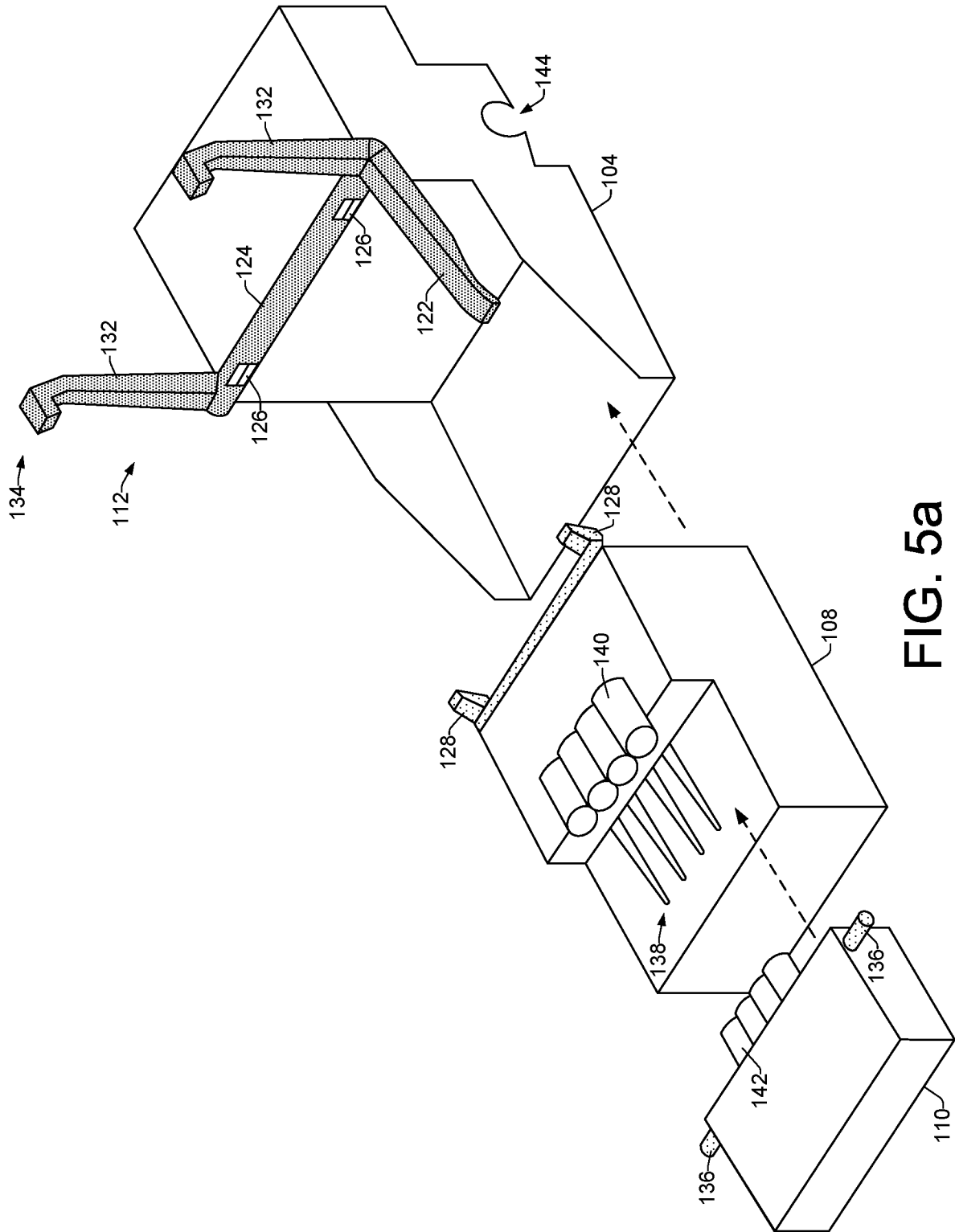

FIG. 5a

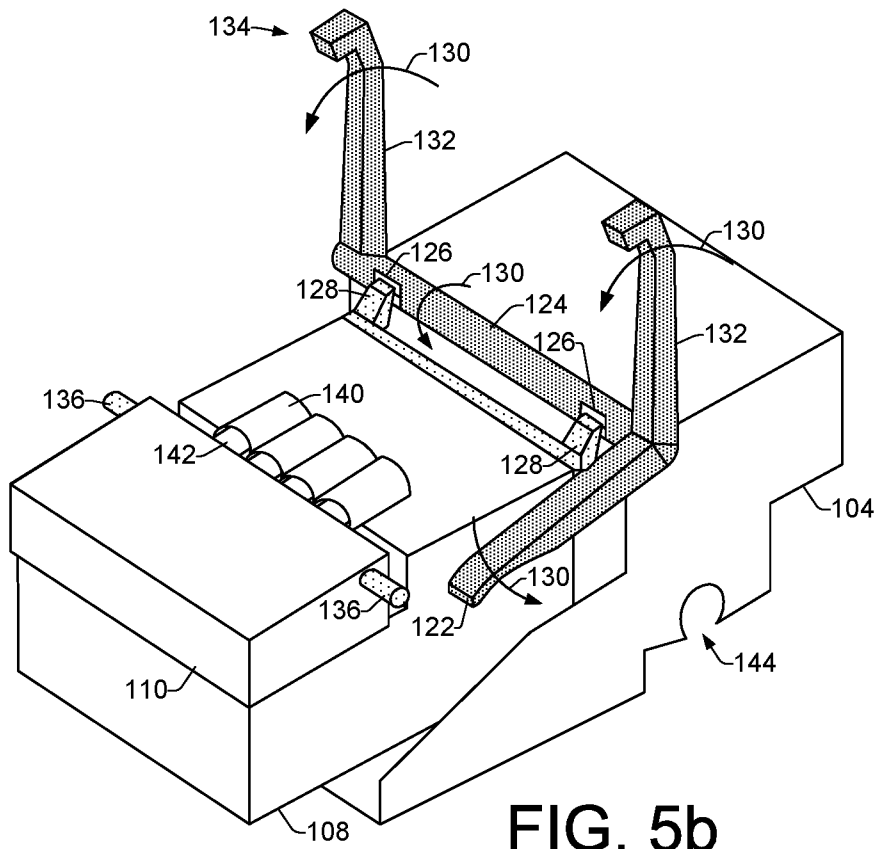

FIG. 5b

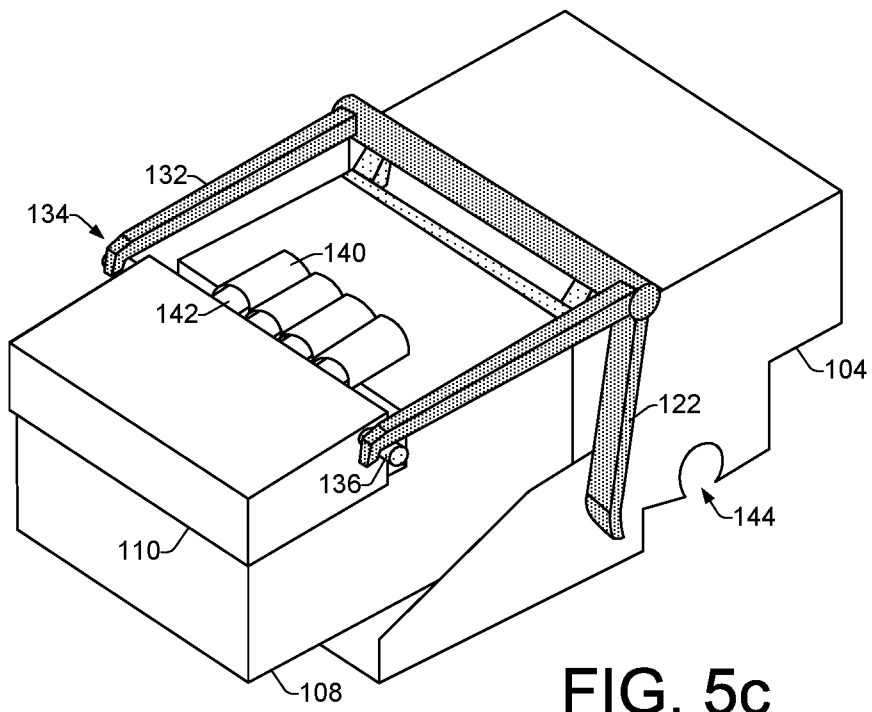
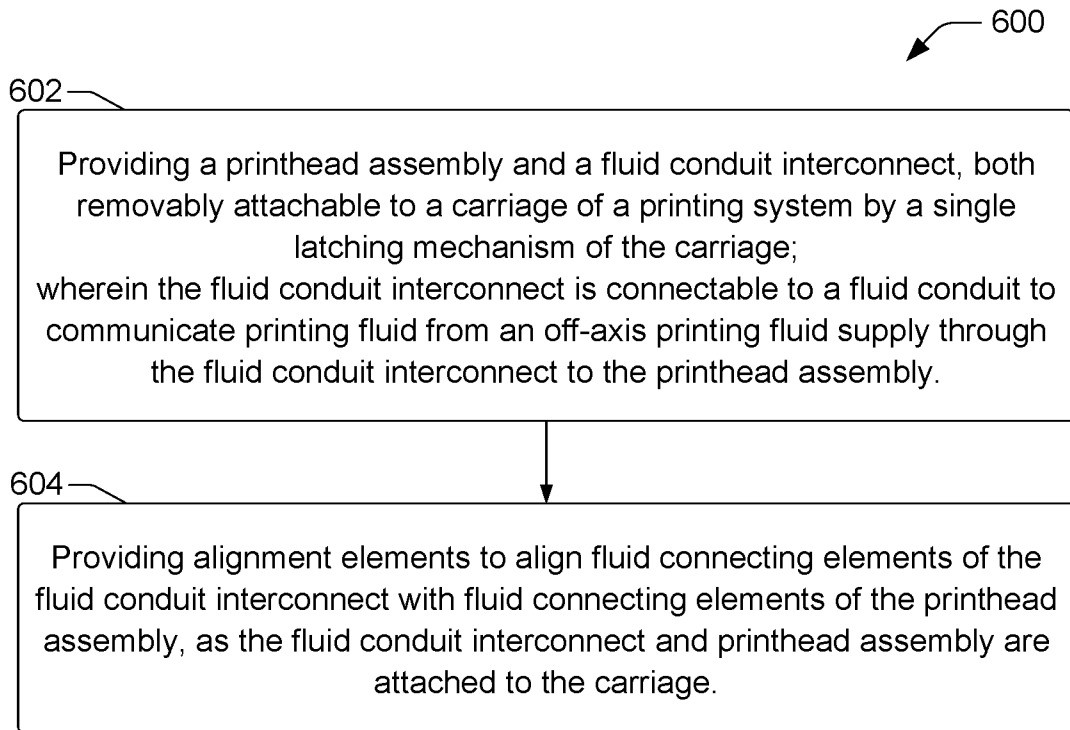

FIG. 5c

**FIG. 6**

A. CLASSIFICATION OF SUBJECT MATTER**B41J 2/175(2006.01)i, B41J 2/135(2006.01)i**

According to International Patent Classification (IPC) or to both national classification and IPC

B. FIELDS SEARCHEDMinimum documentation searched (classification system followed by classification symbols)
B41J 2/175; B41J 23/00; B41J 2/17; 2/16; B41J 25/34; B41J 2/18; B41J 2/135Documentation searched other than minimum documentation to the extent that such documents are included in the fields searched
Korean utility models and applications for utility models
Japanese utility models and applications for utility modelsElectronic data base consulted during the international search (name of data base and, where practicable, search terms used)
eKOMPASS(KIPO internal) & Keywords: printhead, fluid, supply, conduit, interconnect, attachment, engagement, carriage, and latching**C. DOCUMENTS CONSIDERED TO BE RELEVANT**

Category*	Citation of document, with indication, where appropriate, of the relevant passages	Relevant to claim No.
X	EP 0890442 A1 (HEWLETT-PACKARD COMPANY) 13 January 1999 See abstract, column 3, line 48 - column 4, line 56, column 5, lines 15-30, column 6, lines 13-30, claims 1, 2, and figures 1-13.	1, 7-9, 11, 13-15
Y A		10 2-6, 12
Y	US 5691754 A (TA, CHUONG C.) 25 November 1997 See abstract, column 3, lines 1-5, and figure 3.	10
A	US 6206510 B1 (CASSERINO et al.) 27 March 2001 See abstract, column 2, line 25 - column 3, line 42, column 4, line 54 - column 5, line 15, and figures 1-6.	1-15
A	US 6293649 B1 (NORTON, KIRKPATRICK W.) 25 September 2001 See abstract, column 3, lines 61-67, column 5, lines 4-61, claim 1, and figures 1A, 1B.	1-15
A	US 2005-0264626 A1 (CHILDS et al.) 01 December 2005 See abstract, paragraphs [0011]-[0018], and figure 1.	1-15

 Further documents are listed in the continuation of Box C. See patent family annex.

* Special categories of cited documents:

"A" document defining the general state of the art which is not considered to be of particular relevance

"E" earlier application or patent but published on or after the international filing date

"L" document which may throw doubts on priority claim(s) or which is cited to establish the publication date of another citation or other special reason (as specified)

"O" document referring to an oral disclosure, use, exhibition or other means

"P" document published prior to the international filing date but later than the priority date claimed

"T" later document published after the international filing date or priority date and not in conflict with the application but cited to understand the principle or theory underlying the invention

"X" document of particular relevance; the claimed invention cannot be considered novel or cannot be considered to involve an inventive step when the document is taken alone

"Y" document of particular relevance; the claimed invention cannot be considered to involve an inventive step when the document is combined with one or more other such documents, such combination being obvious to a person skilled in the art

"&" document member of the same patent family

Date of the actual completion of the international search

25 October 2016 (25.10.2016)

Date of mailing of the international search report

25 October 2016 (25.10.2016)

Name and mailing address of the ISA/KR

International Application Division
Korean Intellectual Property Office
189 Cheongsa-ro, Seo-gu, Daejeon, 35208, Republic of Korea

Facsimile No. +82-42-481-8578

Authorized officer

KIM, Jin Ho

Telephone No. +82-42-481-8699



INTERNATIONAL SEARCH REPORT

Information on patent family members

International application No.

PCT/US2016/015211

Patent document cited in search report	Publication date	Patent family member(s)	Publication date
EP 0890442 A1	13/01/1999	None	
US 5691754 A	25/11/1997	None	
US 6206510 B1	27/03/2001	DE 10000583 A1 DE 10000583 B4 GB 2351945 A GB 2351945 B US 2001-0002840 A1 US 6679592 B2	02/11/2000 28/07/2005 17/01/2001 18/12/2002 07/06/2001 20/01/2004
US 6293649 B1	25/09/2001	None	
US 2005-0264626 A1	01/12/2005	DE 60300284 T2 EP 1356946 A1 EP 1356946 B1 JP 2003-312012 A JP 4037312 B2 US 2003-0202072 A1 US 6955425 B2 US 7497562 B2	12/01/2006 29/10/2003 26/01/2005 06/11/2003 23/01/2008 30/10/2003 18/10/2005 03/03/2009