

E.D. Cramer's Spring Bottom for

Wagon Bodies. PATENTED JAN 10 1871

110830

Fig. 1.

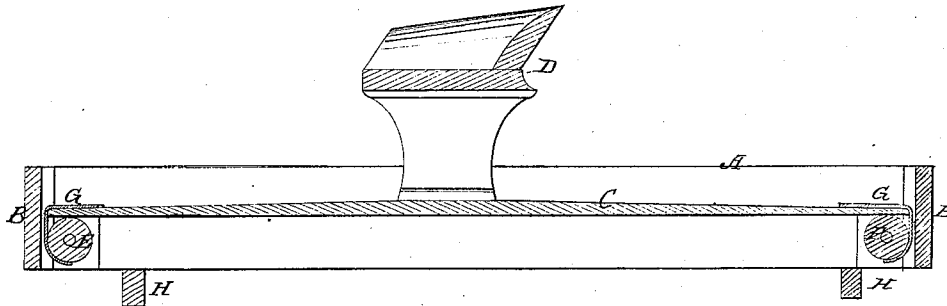
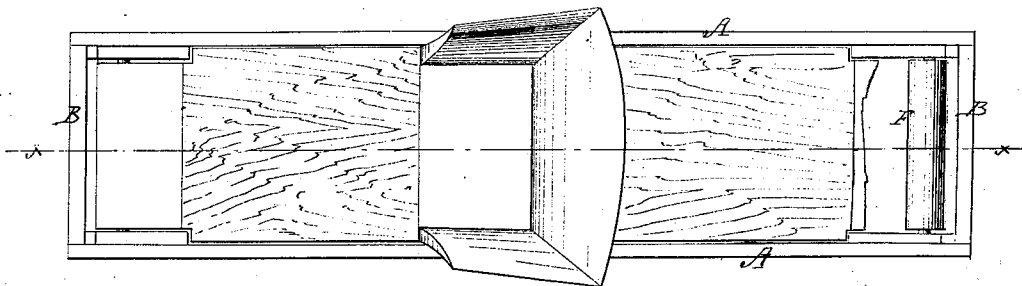

Fig. 2.



Witnesses:

*Chas. Nida
G. S. Maber*

Inventor:

*E. D. Cramer
110
Wm. S.*

Attorneys.

United States Patent Office.

EPHRAIM D. CRAMER, OF HACKETTSTOWN, NEW JERSEY.

Letters Patent No. 110,830, dated January 10, 1871.

IMPROVEMENT IN SPRING-BOTTOMS FOR WAGON-BODIES.

The Schedule referred to in these Letters Patent and making part of the same.

To all whom it may concern:

Be it known that I, EPHRAIM D. CRAMER, of Hackettstown, in the county of Warren and State of New Jersey, have invented a new and useful Improvement in Spring-Bottom for Wagon-Bodies; and I do hereby declare that the following is a full, clear, and exact description thereof, which will enable others skilled in the art to make and use the same, reference being had to the accompanying drawing forming part of this specification.

My invention relates to wagon-bodies provided with spring-bottoms, and consists in an improvement upon the latter, as hereinafter described and pointed out in the claim.

In the accompanying drawing—

Figure 1 is a vertical longitudinal section of a wagon-body provided with my improved spring-bottom, the section being taken on the line *x x* of fig. 2.

Figure 2 is a top or plan view, partly in section.

Similar letters of reference indicate corresponding parts.

A represents the sides, and
B, the ends of the wagon-body.
C is the spring bottom.

D is the seat.

E and F are rollers, which are supported on pivots or gudgeons in their ends by the sides of the body.

The spring-bottom C is made of ash, or of some other tough and springy wood, slightly tapering in thickness from the seat to each end, as seen in the drawing. The ends of the spring rest on the rolls E and F.

G G are pieces of leather, or other flexible material, which are fastened by nailing, cementing, or otherwise, to the ends of the spring and to the rolls. By these pieces G G the spring is kept down and in

place, and a slight rolling motion is imparted to the rollers as the bottom springs, thus preventing any binding or friction between the spring and the rollers.

H H are cross-pieces fastened to the sides of the wagon-body, which rest upon the axles or bolsters of the running-gear, by means of which the body is fastened or secured to the running-gear in any suitable manner.

The spring-bottom may be made in two or more pieces, or a succession of slats may be employed for forming the bottom.

I do not confine myself to the particular mode shown for connecting the bottom with the rollers, as other means may be employed for that purpose.

By this arrangement the spring bottom is raised more or less from the lower edges of the sides of the body, according to the diameter of the rollers, and sufficient play is allowed between the sides and the edges of the bottom to allow the bottom to move freely up and down.

The body of the wagon, when constructed in this manner, may be placed low upon the axles, thus rendering the wagon much more convenient than when hung on steel springs, while all the elasticity, strength, and durability of the elliptic spring is secured at greatly diminished cost.

Having thus described my invention,

I claim as new and desire to secure by Letters Patent—

The end-tapered wooden spring C, flexible strips G G, and rollers E F, combined as described, to form an elastic wagon-body bottom.

EPHRAIM D. CRAMER.

Witnesses:

J. WELSH, JR.,
W. W. GIBBS.