

(19) World Intellectual Property
Organization
International Bureau



(43) International Publication Date
22 December 2005 (22.12.2005)

PCT

(10) International Publication Number
WO 2005/120448 A1

- (51) International Patent Classification⁷: **A61K 7/32**
- (21) International Application Number:
PCT/EP2005/005243
- (22) International Filing Date: 26 April 2005 (26.04.2005)
- (25) Filing Language: English
- (26) Publication Language: English
- (30) Priority Data:
0451140 9 June 2004 (09.06.2004) FR
60/587,041 13 July 2004 (13.07.2004) US
- (71) Applicant (for all designated States except US):
L'OREAL [FR/FR]; 14, rue Royale, F-75008 Paris (FR).
- (72) Inventors; and
- (75) Inventors/Applicants (for US only): **LEMOINE, Cyril** [FR/FR]; 38, rue du Manoir, F-95380 Puiseux-en-France (FR). **BEAU, Nathalie** [FR/FR]; 6, allée du Stade, F-95610 Eragny-sur-Oise (FR).
- (81) Designated States (unless otherwise indicated, for every kind of national protection available): AE, AG, AL, AM, AT, AU, AZ, BA, BB, BG, BR, BW, BY, BZ, CA, CH, CN, CO, CR, CU, CZ, DE, DK, DM, DZ, EC, EE, EG, ES, FI, GB, GD, GE, GH, GM, HR, HU, ID, IL, IN, IS, JP, KE, KG, KM, KP, KR, KZ, LC, LK, LR, LS, LT, LU, LV, MA, MD, MG, MK, MN, MW, MX, MZ, NA, NI, NO, NZ, OM, PG, PH, PL, PT, RO, RU, SC, SD, SE, SG, SK, SL, SM, SY, TJ, TM, TN, TR, TT, TZ, UA, UG, US, UZ, VC, VN, YU, ZA, ZM, ZW.
- (84) Designated States (unless otherwise indicated, for every kind of regional protection available): ARIPO (BW, GH, GM, KE, LS, MW, MZ, NA, SD, SL, SZ, TZ, UG, ZM, ZW), Eurasian (AM, AZ, BY, KG, KZ, MD, RU, TJ, TM), European (AT, BE, BG, CH, CY, CZ, DE, DK, EE, ES, FI, FR, GB, GR, HU, IE, IS, IT, LT, LU, MC, NL, PL, PT, RO, SE, SI, SK, TR), OAPI (BF, BJ, CF, CG, CI, CM, GA, GN, GQ, GW, ML, MR, NE, SN, TD, TG).
- Published:**
— with international search report
- For two-letter codes and other abbreviations, refer to the "Guidance Notes on Codes and Abbreviations" appearing at the beginning of each regular issue of the PCT Gazette.*

(54) Title: USE AS AN ANTIPERSPIRANT AGENT OF A FLOCCULATING WATER-SOLUBLE POLYMER; COSMETIC PROCESS FOR TREATING PERSPIRATION

(57) Abstract: The present invention relates to the use of a flocculating water-soluble polymer comprising amine groups borne by a side substituent directly attached to the main chain, as an antiperspirant active agent in a cosmetic composition and particularly in a cosmetic composition not containing any antiperspirant aluminium and/or zirconium salts. The present invention also relates to a cosmetic process for treating perspiration, which consists in applying to the surface of the skin an effective amount of a flocculating water-soluble polymer comprising amine groups borne by a side substituent directly attached to the main chain.



WO 2005/120448 A1

USE AS AN ANTIPERSPIRANT AGENT OF A FLOCCULATING WATER-SOLUBLE POLYMER; COSMETIC PROCESS FOR TREATING PERSPIRATION

5 The present invention relates to the use of a flocculating water-soluble polymer comprising amine groups borne by a side substituent directly attached to the main chain, as an antiperspirant active agent in a cosmetic composition and particularly in a cosmetic
10 composition not containing any antiperspirant aluminium and/or zirconium salts.

 The present invention also relates to a cosmetic process for treating perspiration, which consists in applying to the surface of the skin an
15 effective amount of a flocculating water-soluble polymer comprising amine groups borne by a side substituent directly attached to the main chain.

 It is well known in cosmetics to use in topical application antiperspirant products containing
20 substances that have the effect of limiting or even suppressing the flow of sweat. These products are generally available in the form of roll-ons, sticks, aerosols or sprays.

 Antiperspirant substances generally consist
25 of aluminium salts or aluminium/zirconium salts. Their antiperspirant efficacy is limited when they are used

alone. The use of these active agents at high concentrations to obtain good efficacy results in formulation difficulties. Furthermore, these substances have an irritant potential to the skin.

5 There is thus a need to find novel antiperspirant active agents that can replace aluminium salts and aluminium/zirconium salts, and that are effective and easy to formulate.

Water-insoluble polymers forming an occlusive
10 film on the skin have already been proposed in patent application WO 95/24105 as antiperspirant active agents. It is not necessary to use standard aluminium salts. The occlusive polymers proposed are of the octacrylamide/acrylates copolymer type or of the vinyl
15 acetate/butyl maleate/isobornyl acrylates copolymer type, alone or in combination with a PVP/linear α -olefin polymer, for instance PVP/eicosene.

Water-insoluble film-forming polymers whose main chain is hydrocarbon-based and which comprise
20 pendent hydrophobic quaternary ammonium groups have also been proposed in patent application WO 95/27473 as antiperspirant active agents.

Patent application WO 01/54658 discloses anhydrous compositions containing a cyanoacrylate
25 monomer that reacts with sweat to form in situ by polymerization a film on the skin that blocks the sweat

ducts.

However, these occlusive film-forming polymers do not make it possible to obtain fully satisfactory antiperspirant efficacy and still elicit
5 formulation problems.

Moisture-absorbing polymers have been proposed as substitutes for standard astringent salts in antiperspirant compositions in patent US 4 743 440. These moisture-absorbing polymers may especially be
10 water-soluble and chosen especially from natural gums (xanthan, agar, carrageenans, guar or gelatin), celluloses (hydroxypropylmethylcellulose, carboxymethylcellulose), polyoxyethylenes, polyvinylpyrrolidones, polycarboxyvinyls or vinyl ether/maleic
15 anhydride copolymers. In patent application WO 03/030 853, the recommended moisture-absorbing polymers are chosen from grafted starch homopolymers and copolymers of 2-propenamide-co-propenoic acid sodium salt.

20 However, these moisture-absorbing polymers do not make it possible to obtain fully satisfactory antiperspirant efficacy and still elicit formulation problems.

Water-soluble quaternary polymers have been
25 proposed in antiperspirant compositions in the presence of standard aluminium salts to improve their efficacy.

This is the case for dimethyldiallylammonium chloride in patent application EP 222 580, which acts as an agent for retaining the antiperspirant salt. This is the case for the water-soluble polymers comprising a
5 Brönsted acid in patent application WO 02/49590, in particular those derived from maleic acid and/or maleic anhydride, which act as co-gelling agent with the antiperspirant salts. This is the case for polyethyleneimines (PEI) in the article Cosmetics &
10 Toiletries Vol. 108 August 1993 pages 73-77, which act as complexing agents for the aluminium salts.

Dimethyldiallylammonium chloride/acrylic acid copolymers have been proposed in patent application EP 478 327 as thickeners in aqueous liquid
15 antiperspirant products containing aluminium salts.

In patent US 4 690 817, film-forming polymers of vinyl alcohols containing pendent quaternary amine groups have been proposed in antiperspirant compositions in the presence of standard astringent
20 salts as skin conditioners, forming a moisturizing barrier thereon.

In patent application WO 82/01993, polyethyleneimines have been used as odour absorbers in particular of fatty acids, aldehydes or ketones and
25 more particularly in alcohol-based deodorant products in spray or roll-on form.

The Applicant has discovered, surprisingly, that flocculating water-soluble cationic polymers comprising amine groups borne by a side substituent directly attached to the main chain constitute by themselves excellent antiperspirants and can be easily formulated in numerous products for treating perspiration and perspiration-related body odour, without it being necessary to use standard astringent salts.

10 One subject of the present invention is the use of a flocculating water-soluble polymer comprising amine groups borne by a side substituent directly attached to the main chain as an antiperspirant active agent in a cosmetic composition and particularly in a
15 cosmetic composition not containing any antiperspirant aluminium and/or zirconium salts.

A subject of the present invention is also a cosmetic process for treating perspiration, which consists in applying to the surface of the skin an
20 effective amount of a flocculating water-soluble polymer comprising amine groups borne by a side substituent directly attached to the main chain.

The term "antiperspirant agent" means any substance which, by itself, has the effect of reducing
25 or limiting the flow of sweat without it being necessary to use an aluminium and/or zirconium

antiperspirant salt.

The term "water-soluble polymer" means polymers which, when introduced into an aqueous phase at 25°C, at a mass concentration equal to 1%, make it possible to obtain a macroscopically homogeneous and transparent solution, i.e. a solution that has a minimum light transmittance value, at a wavelength equal to 500 nm, through a sample 1 cm thick, of at least 80% and preferably of at least 90%.

10 The term "flocculant" means any substance capable of destabilizing a colloidal suspension indistinctly via a flocculation or coagulation mechanism. The term "destabilization of colloids" means the formation of aggregates that make the suspension
15 unstable. Since the terms flocculation and coagulation are generally interchangeable and equivalent, we will use the term "flocculation" in the invention to refer to either mechanism. The definitions of these mechanisms are given in Volume 10 of "Encyclopedia of
20 Chemical Technology; Kirk-Othmer; 3rd edition".

From an experimental point of view, according to the invention, a flocculant will be considered as effective in antiperspirant terms if it reduces by at least 10% and better still 20% the transmittance
25 measured at a wavelength of 700 nm of a solution of natural sweat filtered through a 200 micron filter.

The term "composition not containing any antiperspirant aluminium and/or zirconium salts" means any composition containing not more than 1% by weight of antiperspirant aluminium and/or zirconium salt.

5 The flocculating water-soluble polymers of the invention may be in the form of homopolymer, copolymer or terpolymer containing at least one monomer of quaternary ammonium type or a monomer of acrylamide type.

10 According to the invention, the term "polymer containing a monomer of quaternary ammonium type" means any polymer for which at least one amine derived from the side substituents is in the form of a quaternary amine between pH 4 and pH 8.

15 A nonionic spacer may optionally be introduced into these polymers, such as the following groups: alkylacrylates; alkylmethacrylates; vinyl-lactams such as vinylcaprolactone; vinylpyrrolidone; vinyl esters; vinyl alcohols; alkylene glycol, for
20 instance propylene glycol or ethylene glycol.

The molar masses of these polymers generally range from 1000 to 20 000 000 g/mol, and they preferably have a molar mass ranging from 10 000 to 1 000 000 g/mol.

25 Among the flocculating water-soluble polymers comprising quaternary ammonium or amide groups that are

pendent relative to the main chain, which may be used in the compositions of the invention, mention may be made of:

- (i) vinyl homopolymers or copolymers comprising at least one quaternary ammonium monomer and/or a (meth)acrylamide monomer;
- (ii) cationic polysaccharides;
- (iii) mixtures thereof.

10 Vinyl polymers comprising at least one quaternary ammonium monomer and/or a (meth)acrylamide monomer

Among the vinyl polymers comprising at least one quaternary ammonium monomer and/or one (meth)acrylamide monomer in accordance with the invention, use will be made of those comprising at least one of the units of formulae (A), (B), (C), (D), (E) and (F) below

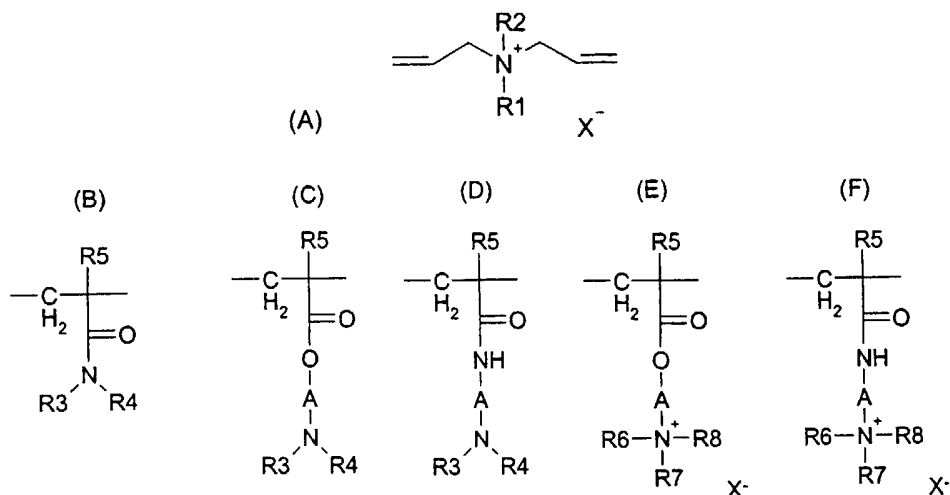

in which:

R1 and R2 independently represent a linear or branched C₁-C₈ alkyl group, a benzyl group, a C₁-C₅ hydroxyalkyl group or a linear or branched amido(C₁-C₄)alkyl group;

5 R3 and R4 independently represent a hydrogen atom or a linear or branched alkyl group containing from 1 to 6 carbon atoms, and preferably methyl or ethyl;

R5 represents a hydrogen atom or an alkyl group containing from 1 to 3 carbon atoms, and preferably
10 methyl;

A is a linear or branched C₁-C₆ and preferably C₂-C₃ alkyl group; a C₁-C₄ hydroxyalkyl group;

R6, R7 and R8, which may be identical or different, represent a hydrogen atom, a linear or branched C₁-C₆
15 alkyl group or a benzyl radical;

X denotes a mineral anion, for instance a halide (chloride, bromide or iodide) or an organic anion, for instance a (C₁-C₄)alkyl sulfate (methyl sulfate or ethyl sulfate).

20 These polymers and their syntheses are described especially in patents US 5 273 021 and FR 2 190 406 and also patents US 5 837 100 and US 5 723 021; patent application WO 03/028 683 and L'Oréal patent FR 2 774 901.

25 The preferred units of formula (A) are diallyldimethylammonium chloride (DADMAC) and diallyl-

diethylammonium chloride (DADEAC).

The preferred units of formula (B) are methacrylamide or acrylamide, and more particularly acrylamide.

5 The units (C), (D), (E) and (F) may be chosen from methylaminoethyl methacrylate, benzyl dimethylaminoethylacrylate chloride (DMAEA-BCQ), acryloyloxyethyltrimethylammonium chloride (AETAC); methacryloyloxyethyltrimethylammonium chloride (METAC); methacrylamidopropyltrimethylammonium chloride (MAPTAC); acrylamidopropyltrimethylammonium chloride (APTAC);
10 acryloyloxyethyltrimethylammonium methosulfate (AETAMS); methacryloyloxyethyltrimethylammonium methosulfate (METAMS); acryloyloxyethyldiethylmethylammonium
15 chloride; methacryloyloxyethyldiethylmethylammonium chloride or the equivalent thereof neutralized with a methyl sulfate.

 The most preferred are benzyl dimethylaminoethylacrylate chloride (DMAEA-BCQ), acryloyloxyethyl
20 trimethylammonium chloride (AETAC), methacryloyloxyethyltrimethylammonium methosulfate (METAMS) and methylaminoethyl methacrylate.

 One particular family of vinyl polymers comprising at least one quaternary ammonium monomer
25 and/or one (meth)acrylamide monomer comprises diallyldimethylammonium chloride (DADMAC) homopolymers with a

molar mass ranging from 10 000 to 1 000 000 g/mol, for instance Polyquaternium-6 (INCI name) of structure:

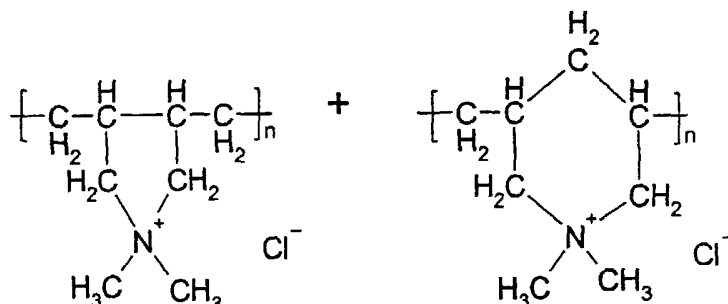

Commercial products that may be mentioned

5 include:

Merquat 100[®] (Ondeo Nalco): molar mass: 150 000 g/mol,

Flocare C106[®]: (SNF): molar mass: 400 000 g/mol, and

Floquat FL45[®] (SNF).

Another particular family comprises acryl-
10 amide homopolymers with a molar mass ranging from
10 000 to 25 million g/mol, of structure:

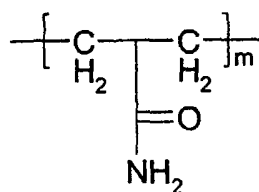

Commercial products that may be mentioned

include:

15 Flocare T920 GC[®] (SNF): molar mass: 8 000 000 g/mol,

Cinamer P250[®] (Cytec), Superfloc N300 LMW[®] (Cytec).

Another particular family comprises acryl-
amide/benzyl dimethylaminoethylacrylate chloride
(DMAEA-BCQ) copolymers with a molar mass ranging from

12

3 to 20 million g/mol and of structure

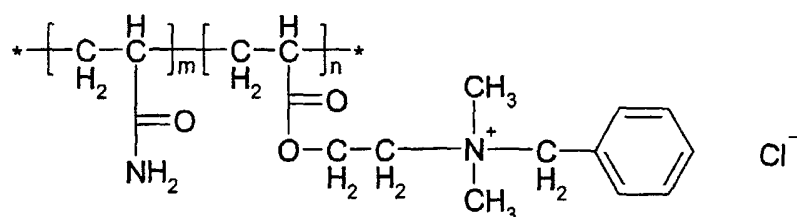

for instance the commercial product Ultimer CG[®] (Ondeo Nalco): ratio: 90/10 and molar mass: about

5 5 000 000 g/mol.

Another particular family comprises acrylamide/acryloyloxyethyltrimethylammonium chloride (AETAC) copolymers or Polyquaternium-33 (INCI name) of structure:

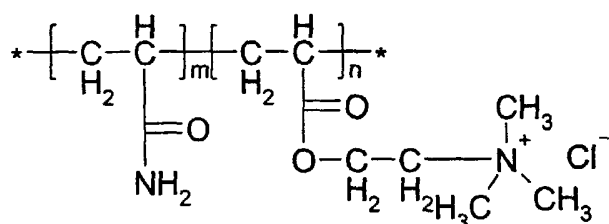

10

for instance the commercial products Floerger FO 4190 VHM[®] (SNF); Floerger FO 4190 SH[®] (SNF); Floerger FO 4550 BPM[®] (SNF): m/n ratio = 55/45 and molar mass: 1 000 000 g/mol.

15

Another particular family comprises acrylamide/methacryloyloxyethyltrimethylammonium methyl sulfate copolymers or Polyquaternium-5 (INCI name) of structure:

chloride/benzyl dimethylaminoethylacrylate chloride
type, of structure:

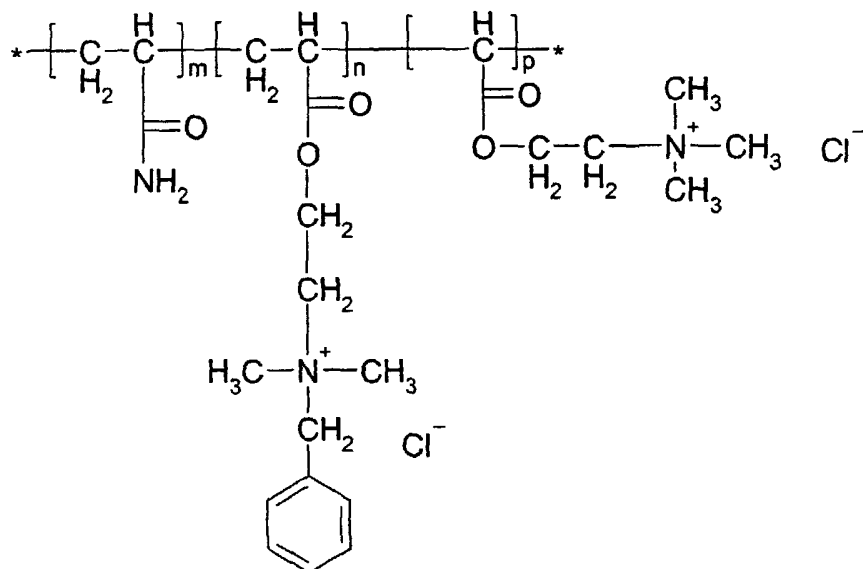

in which the ratio m/n/p is 20/50/30 and the molar mass
5 is 5 000 000 g/mol, for instance the commercial product
Ultimer CG-400®.

Mention may also be made of methylaminoethyl
methacrylate/vinylcaprolactam/vinylpyrrolidone
terpolymers, for instance the commercial product Gaffix
10 VC713® (ISP).

Cationic polysaccharide polymers

Mention may be made especially of cationic
celluloses, starches and galactomannan gums.

15 More particularly, mention may be made of
cellulose ethers comprising quaternary ammonium groups,
cationic cellulose copolymers or celluloses grafted
with a water-soluble quaternary ammonium monomer and

cationic galactomannan gums.

Cellulose ethers comprising quaternary ammonium groups are described in French patent FR 1 492 597, and in particular the polymers sold under the names "JR[®]" (JR 400, JR 125 or JR 30 M) or LR[®] (LR 400 or LR 30 M) from the company Amerchol, or Celquat SC-240 from the company National Starch. These polymers are also defined in the CTFA dictionary as quaternary ammoniums of hydroxycellulose or Polyquaternium-10 that have reacted with an epoxide substituted with a trimethylammonium.

Cationic cellulose copolymers or celluloses grafted with a water-soluble quaternary ammonium monomer are described especially in patent US 4 131 576. Mention may be made especially of hydroxyalkyl celluloses, for instance hydroxymethyl-, hydroxyethyl- or hydroxypropyl celluloses grafted especially with a methacryloylethyltrimethylammonium, methacrylamidopropyltrimethylammonium or dimethyldiallylammonium salt. The marketed products are more particularly the products sold under the name Celquat L200[®] and Celquat H100[®] by the company National Starch.

Cationic galactomannan gums are described more particularly in patent US 4 031 307, in particular guar gums containing cationic trialkylammonium groups.

For example, guar gums modified with a 2,3-epoxypropyl-trimethylammonium salt (for example chloride) may be used. Such products are especially sold under the trade names: Jaguar C13S[®] or Jaguar C17[®] by the company
5 Rhodia Chimie, or Cosmedia Guar C261 N[®] from the company Cognis.

Starches modified with a 2,3-epoxypropyltrimethylammonium salt (for example chloride) are also used, such as the product known as Starch
10 Hydroxypropyltrimonium Chloride according to the INCI nomenclature and sold under the name Sensomer CI-50[®] by the company Ondeo-Nalco.

The flocculating water-soluble polymers used as antiperspirant active agents are preferably present
15 in the compositions according to the invention in amounts ranging from 0.1% to 50% and more preferably from 1% to 20% by weight relative to the total weight of the composition.

The compositions according to the invention
20 intended for cosmetic use may be in the form of lotions, creams or fluid gels distributed as an aerosol spray, in a pump-dispenser bottle or as a roll-on, in the form of thick creams distributed in tubes or a grille; in the form of wands (sticks), and may contain
25 in this regard the ingredients generally used in products of this type and well known to those skilled

in the art.

The compositions according to the present invention intended for cosmetic use may comprise at least one aqueous phase. They are especially formulated
5 as aqueous lotions or as water-in-oil, oil-in-water emulsions, or as multiple emulsions (oil-in-water-in-oil or water-in-oil-in-water triple emulsions (such emulsions are known and described, for example, by C. Fox in "Cosmetics and Toiletries", November 1986, Vol.
10 101, pages 101-112)).

The aqueous phase of the said compositions contains water and generally other water-soluble or water-miscible solvents. The water-soluble or water-miscible solvents include short-chain monoalcohols, for
15 example of C₁-C₄, for instance ethanol or isopropanol; diols or polyols, for instance ethylene glycol, 1,2-propylene glycol, 1,3-butylene glycol, hexylene glycol, diethylene glycol, dipropylene glycol, 2-ethoxyethanol, diethylene glycol monomethyl ether, triethylene glycol
20 monomethyl ether and sorbitol. Propylene glycol and glycerol will more particularly be used.

According to one particular form of the invention, the antiperspirant compositions may be anhydrous.

25 For the purposes of the invention, the term "anhydrous" refers to a composition whose content of

free or added water is less than 3% and preferably whose content of added water is less than 1% by weight relative to the total weight of the composition.

The compositions according to the invention preferably comprise at least one water-immiscible organic liquid phase. This phase generally comprises one or more hydrophobic compounds that render the said phase water-immiscible. The said phase is liquid (in the absence of a structuring agent) at room temperature (20-25°C). Preferentially the water-immiscible organic liquid phase in accordance with the invention generally consists of an oil or a mixture of oils and comprises at least 80% of compounds with a vapour pressure not exceeding 4 kPa (30 mmHg) at 25°C.

The water-immiscible organic liquid phase preferably contains one or more volatile or non-volatile, silicone-based or hydrocarbon-based emollient oils. These emollient oils are especially described in patents US 4 822 596 and US 4 904 463.

Volatile silicones are defined, in a known manner, as being compounds that are volatile at room temperature. Mention may be made among these compounds of cyclic and linear volatile silicones of the dimethylsiloxane type whose chains comprise from 3 to 9 silicone-based residues. Cyclomethicones D₄, D₅ or D₆ are preferably chosen.

Non-volatile silicones are defined, in a known manner, as being compounds with a low vapour pressure at room temperature. The following are included among these compounds: polyalkylsiloxanes, in particular linear polyalkylsiloxanes, for instance the linear polydimethylsiloxanes, or dimethicones, sold by the company Dow Corning under the name "Dow Corning 245 Fluid"; polyalkylarylsiloxanes, for instance the polymethylphenylsiloxanes sold by the company Dow Corning under the name "Dow Corning 556 Fluid"; copolymers of polyether and siloxane, for instance dimethicone copolyols.

Among the non-volatile emollient oils that may be used in the present invention, examples that may be mentioned include: hydrocarbon-based derivatives, mineral oils, fatty alcohols, esters of C₃-C₁₈ alcohols with C₃-C₁₈ acids, esters of benzoic acid with C₁₂-C₁₈ alcohols and mixtures thereof, C₂-C₆ polyols preferably chosen from glycerol, propylene glycol or sorbitol, polyalkylene glycol polymers.

The emollient oils are preferably present in amounts ranging from 1% to 50% by weight and more preferably from 5% to 40% by weight relative to the total weight of the composition.

The cosmetic compositions according to the invention may contain one or more additional deodorant

active agents, for instance

- bacteriostatic agents or bactericidal agents such as 2,4,4'-trichloro-2'-hydroxydiphenyl ether (Triclosan), 2,4-dichloro-2'-hydroxydiphenyl ether, 3',4',5'-trichlorosalicylanilide, 1-(3',4'-dichlorophenyl)-3-(4'-chlorophenyl)urea (Triclocarban) or 3,7,11-trimethyldodeca-2,5,10-trienol (Farnesol); quaternary ammonium salts, for instance cetyltrimethylammonium salts or cetylpyridinium salts; chlorhexidine and salts; diglyceryl monocaprate, diglyceryl monolaurate or glyceryl monolaurate; polyhexamethylene biguanide salts, or mixtures thereof;
- zinc salts, for instance zinc salicylate, zinc phenolsulfonate, zinc pyrrolidonecarboxylate (more commonly known as zinc pidolate), zinc sulfate, zinc chloride, zinc lactate, zinc gluconate, zinc ricinoleate, zinc glycinate, zinc carbonate, zinc citrate, zinc chloride, zinc laurate, zinc oleate, zinc orthophosphate, zinc stearate, zinc silicate, zinc tartrate, zinc lactate and zinc acetate, or mixtures thereof.

In order to improve the antiperspirant efficacy of the composition, one or more water-soluble anionic polymers comprising a Brönsted acid, in particular those derived from maleic acid and/or from maleic anhydride, which are described in patent

application WO 02/49590, may also be used.

In order to improve the homogeneity of the product, it is possible also to use one or more suspension agents preferably chosen from hydrophobic-
5 modified montmorillonite clays, for instance hydrophobic-modified bentonites or hectorites. Examples that may be mentioned include the product stearalkonium bentonite (CTFA name) (product of reaction of bentonite and the quaternary ammonium stearalkonium chloride),
10 such as the commercial product sold under the name Tixogel MP 250 by the company Süd Chemie Rheologicals, United Catalysts Inc. or the product disteardimonium hectorite (CTFA name) (product of reaction of hectorite and of distearyldimonium chloride) sold under the name
15 Bentone 38 or Bentone Gel by the company Elementis Specialities.

The suspension agents are preferably present in amounts ranging from 0.1% to 5% by weight and more preferably from 0.2% to 2% by weight relative to the
20 total weight of the composition.

The compositions according to the invention may also contain at least one organic powder.

Among the fillers that may be used according to the invention, mention may be made of organic
25 powders. In the present patent application, the term "organic powder" means any solid that is insoluble in

the medium at room temperature (25°C).

As organic powders that may be used in the composition of the invention, examples that may be mentioned include polyamide particles and especially those sold under the name Orgasol by the company Atochem; polyethylene powders; microspheres based on acrylic copolymers, such as those made of ethylene glycol dimethacrylate/lauryl methacrylate copolymer, sold by the company Dow Corning under the name Polytrap; polymethyl methacrylate microspheres, sold under the name Microsphere M-100 by the company Matsumoto or under the name Covabead LH85 by the company Wackherr; ethylene-acrylate copolymer powders, for instance those sold under the name Flobeads by the company Sumitomo Seika Chemicals; expanded powders such as hollow microspheres and especially microspheres formed from a terpolymer of vinylidene chloride, of acrylonitrile and of methacrylate and sold under the name Expancel by the company Kemanord Plast under the references 551 DE 12 (particle size of about 12 μm and density of 40 kg/m^3), 551 DE 20 (particle size of about 30 μm and a density of 65 kg/m^3) and 551 DE 50 (particle size of about 40 μm), or the microspheres sold under the name Micropearl F 80 ED by the company Matsumoto; powders of natural organic materials such as starch powders, especially of corn starch, wheat starch or

rice starch, which may or may not be crosslinked, such as the starch powder crosslinked with octenylsuccinate anhydride, sold under the name Dry-Flo by the company National Starch; silicone resin microbeads such as
5 those sold under the name Tospearl by the company Toshiba Silicone, especially Tospearl 240; amino acid powders such as the lauroyllysine powder sold under the name Amihope LL-11 by the company Ajinomoto; particles of wax microdispersion, which preferably have mean
10 sizes of less than 1 μm and especially ranging from 0.02 μm to 1 μm , and which consist essentially of a wax or a mixture of waxes, such as the products sold under the name Aquacer by the company Byk Cera, and especially: Aquacer 520 (mixture of synthetic and
15 natural waxes), Aquacer 514 or 513 (polyethylene wax), Aquacer 511 (polymer wax), or such as the products sold under the name Jonwax 120 by the company Johnson Polymer (mixture of polyethylene wax and paraffin wax) and under the name Ceraflour 961 by the company Byk
20 Cera (micronized modified polyethylene wax); and mixtures thereof. The organic powder(s) may be present, for example, in an amount

The cosmetic compositions according to the invention may also comprise cosmetic adjuvants chosen
25 from waxes, softeners, antioxidants, opacifiers, stabilizers, moisturizers, vitamins, fragrances,

bactericides, preserving agents, polymers, fragrances, thickeners, propellants or any other ingredient usually used in cosmetics for this type of application.

Needless to say, a person skilled in the art
5 will take care to select this or these optional additional compound(s) such that the advantageous properties intrinsically associated with the cosmetic composition in accordance with the invention are not, or are not substantially, adversely affected by the
10 envisaged addition(s).

The waxes may be chosen from animal, fossil, plant, mineral and synthetic waxes. Mention may be made especially of beeswaxes, carnauba wax, candelilla wax, sugar cane wax, Japan wax, ozokerites, montan wax,
15 microcrystalline waxes, paraffins and silicone waxes and resins.

The thickeners, which are preferably nonionic, may be chosen from modified or unmodified guar gums and celluloses, such as hydroxypropyl guar
20 gum or cetylhydroxyethylcellulose, silicas, for instance Bentone Gel MIO sold by the company NL Industries, or Veegum Ultra sold by the company Polyplastic.

The amounts of these various constituents
25 that may be present in the cosmetic composition according to the invention are those conventionally

used in deodorant compositions.

The compositions according to the invention may also contain one or more other agents for structuring or gelling the water-immiscible organic liquid phase of the composition, such as linear solid fatty alcohols and/or waxes; fatty acids or salts thereof (stearic acid, sodium stearate or 12-hydroxystearic acid; dibenzylidene alditols (DBS); lanosterol, N-acylamino acid derivatives; di- or tricarboxylic acid derivatives, for instance alkyl-N,N'-dialkylsuccinamides (i.e.: dodecyl-N,N'-dibutylsuccinamide); elastomeric polyorganosiloxanes such as those described in patent application WO 97/44010.

The compositions according to the invention may also be pressurized and may be packaged in an aerosol device consisting of:

- (A) a container comprising a deodorant composition as defined above,
- (B) at least one propellant and a means for distributing the said aerosol composition.

The propellants generally used in products of this type, which are well known to those skilled in the art, are, for example, dimethyl ether (DME); volatile hydrocarbons such as n-butane, propane or isobutane, and mixtures thereof, optionally with at least one chlorohydrocarbon and/or fluorohydrocarbon; among the

latter, mention may be made of the compounds sold by the company Dupont de Nemours under the names Freon[®] and Dymel[®], and in particular monofluorotrifluoromethane, difluorodichloromethane, tetrafluorodichloroethane and 1,1-difluoroethane sold especially under the trade name Dymel 152 A by the company Dupont. Carbon dioxide, nitrous oxide, nitrogen or compressed air may also be used as propellant.

The compositions containing the antiperspirant active polymer(s) as defined above and the propellant(s) may be in the same compartment or in different compartments in the aerosol container. According to the invention, the concentration of propellant generally ranges from 5% to 95% by pressurized weight and more preferably from 50% to 85% by weight relative to the total weight of the pressurized composition.

The distribution means, which forms a part of the aerosol device, generally consists of a distribution valve controlled by a distribution head, itself comprising a nozzle via which the aerosol composition is vaporized. The container containing the pressurized composition may be opaque or transparent. It may be made of glass, of polymeric material or of metal, optionally coated with a coat of protective varnish.

The examples that follow serve to illustrate the present invention.

Example 1: Antiperspirant stick

Ingredients	Amount in weight %
Cyclopentasiloxane (DC 245 Fluid from Dow Corning)	33
PPG-14 butyl ether (Ucon Fluid AP - Amerchol)	10
Hydrogenated castor oil (Cutina HR Pulver - Cognis)	4
Talc	2
Polyquaternium-5 (Merquat-5 - Ondeo Nalco)	20
Stearyl alcohol	14
PEG-8 distearate (Stearinerie Dubois)	2
C ₁₂₋₁₅ Alkyl benzoate (Finsolv TN - Witco)	15

5 **Procedure:**

The cyclopentasiloxane is heated to 65°C. The other ingredients are added one by one, while keeping the temperature at 65-70°C. The mixture (transparent solution) is homogenized for 15 minutes. It is cooled
10 to about 55°C (a few degrees Celsius above the

thickening point of the mixture) and poured into sticks. The sticks are placed at 4°C for 30 minutes.

Example 2: Antiperspirant emulsion (roll-on)

Phase	Ingredients	Amount in weight %
A	Polyquaternium-7 (40%) (Salcare Super 7 - Ciba)	20
	Zinc gluconate (Givobio G Zn - SEPPIC)	2
B	Steareth-21 (Brij 721 - ICI)	2
	Steareth-2 (Brij 72 - ICI)	2
	Steareth-5 stearate (Arlatone 985 - ICI)	1
	PPG-15 stearyl ether (Arlamol E - ICI)	1.5
	Cyclopentasiloxane (DC 245 Fluid from Dow Corning)	3.5
C	Water	68

5 **Procedure:**

Phases (B) and (C) are separately heated to 70°C. (B) and (C) are mixed together with a Turrax blender for 5 minutes and then cooled to 55°C with paddle stirring. Phase A is added gently with stirring.

The mixture is homogenized for 1 to 3 minutes. It is cooled to 35°C with stirring.

Example 3: Antiperspirant vaporizer (PIT emulsion)

Ingredients	Amount in weight %
Polyquaternium-6 (40%) (Merquat 100 - Ondeo Nalco)	20
Cetearyl isononanoate (and) cetearyl alcohol (and) Cetareth-20 (and) glycerol (and) glyceryl stearate (and) Cetareth-12 (and) cetyl palmitate (Emulgade CM - Cognis)	15
Water	65

5 **Procedure:**

The polyquaternium-6 is dissolved in water and the "Emulgade CM" is added to the mixture with moderate stirring.

10 **Example 4: Antiperspirant aerosol**

Ingredients	Amount in weight %
Stearalkonium bentonite (Tixogel MP 250 - Süd Chemie)	0.5
Polyquaternium-10	5

(Ucare Polymer JR 125 - Amerchol)	
C ₁₂₋₁₅ Alkyl benzoate (Finsolv TN - Witco)	3
Triethyl citrate (Citroflex 2: Morflex)	1
Isopropyl palmitate	1
Cyclopentasiloxane (DC 245 Fluid from Dow Corning)	9.5
Isobutane (propellant)	80

CLAIMS

1. Use of a flocculating water-soluble polymer comprising amine groups borne by a side substituent directly attached to the main chain, as an antiperspirant active agent in a cosmetic composition.
2. Use of a flocculating water-soluble polymer in a cosmetic composition not containing any antiperspirant aluminium and/or zirconium salts.
3. Use according to Claim 1 or 2, in which the flocculating water-soluble polymers are in the form of a homopolymer, copolymer or terpolymer containing at least one monomer of quaternary ammonium type and/or a monomer of acrylamide type.
4. Use according to any one of Claims 1 to 3, in which the flocculating water-soluble polymers may also contain a nonionic spacer.
5. Use according to Claim 4, in which the nonionic spacer is chosen from the following groups:
alkylacrylates; alkylmethacrylates; vinyl lactams; vinyl esters; vinyl alcohols; alkylene glycols.
6. Use according to any one of Claims 1 to 5, in which the flocculating water-soluble polymers have a molar mass ranging from 1000 to 20 000 000 g/mol and preferably ranging from 10 000 to 1 000 000 g/mol.
7. Use according to any one of Claims 1 to

6, in which the flocculating water-soluble polymers are chosen from:

- (i) vinyl homopolymers or copolymers comprising at least one quaternary ammonium monomer and/or a (meth)acrylamide monomer;
- (ii) cationic polysaccharides;
- (iii) mixtures thereof.

8. Use according to any one of Claims 1 to 7, in which the flocculating water-soluble polymers are chosen from those comprising at least one of the units of formulae (A), (B), (C), (D), (E) and (F) below:

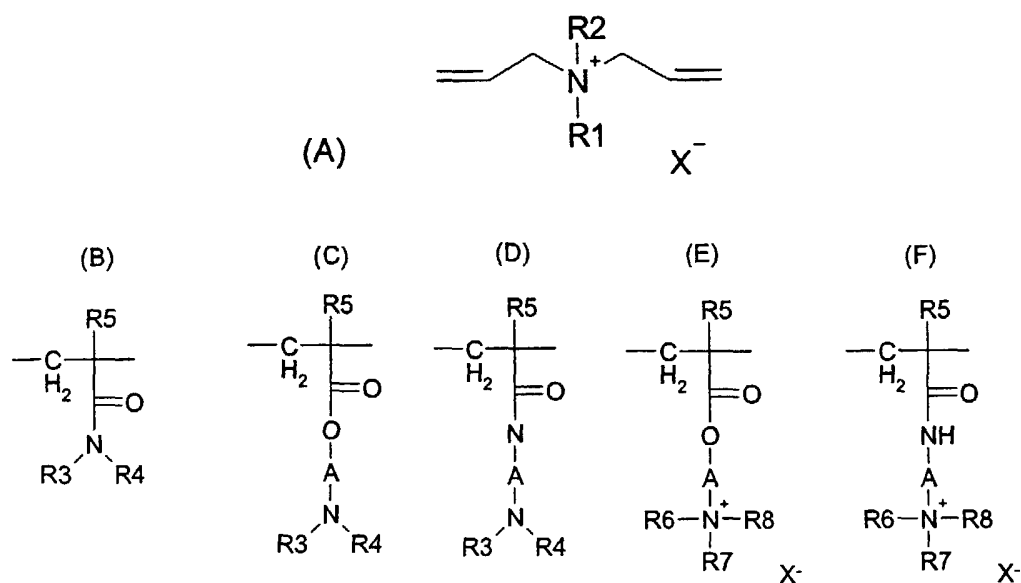

in which:

- 15 R1 and R2 independently represent a linear or branched C₁-C₃ alkyl group, a benzyl group, a C₁-C₅ hydroxyalkyl group or a linear or branched amido(C₁-C₄)alkyl group;
- R3 and R4 independently represent a hydrogen atom or a linear or branched alkyl group containing from 1 to

6 carbon atoms;

R5 represents a hydrogen atom or an alkyl group containing from 1 to 3 carbon atoms;

A is a linear or branched C₁-C₆ alkyl group or a C₁-C₄ hydroxyalkyl group;

R6, R7 and R8, which may be identical or different, represent a hydrogen atom, a linear or branched C₁-C₆ alkyl group or a benzyl radical;

X denotes a mineral or organic anion.

10 9. Use according to Claim 8, in which the unit of formula (A) is diallyldimethylammonium chloride (DADMAC) or diallyldiethylammonium chloride (DADEAC).

10. Use according to Claim 8, in which the unit of formula (B) is methacrylamide or acrylamide.

15 11. Use according to Claim 8, in which the units (C), (D), (E) and (F) are chosen from methylaminoethyl methacrylate, benzyl dimethyl- aminoethylacrylate chloride (DMAEA-BCQ), acryloyloxy- ethyltrimethylammonium chloride (AETAC); methacryloyl-
20 oxyethyltrimethylammonium chloride (METAC); methacryl- amidopropyltrimethylammonium chloride (MAPTAC); acryl- amidopropyltrimethylammonium chloride (APTAC); acryloyloxyethyltrimethylammonium methosulfate (AETAMS); methacryloyloxyethyltrimethylammonium metho-
25 sulfate (METAMS); acryloyloxyethyldiethylmethylammonium chloride; methacryloyloxyethyldiethylmethylammonium

chloride or the equivalent thereof neutralized with a methyl sulfate.

12. Use according to any one of Claims 1 to 9, in which the flocculating water-soluble polymers are chosen from diallyldimethylammonium chloride (DADMAC) homopolymers with a molecular mass ranging from 10 000 to 1 000 000 g/mol.

13. Use according to any one of Claims 1 to 10, in which the flocculating water-soluble polymers are chosen from acrylamide homopolymers with a molar mass ranging from 10 000 to 25 000 000 g/mol.

14. Use according to any one of Claims 1 to 11, in which the flocculating water-soluble polymers are chosen from acrylamide/benzyl dimethylaminoethyl-acrylate chloride (DMAEA-BCQ) copolymers with a molar mass ranging from 3 to 20 000 000 g/mol.

15. Use according to any one of Claims 1 to 11, in which the flocculating water-soluble polymers are chosen from acrylamide/acryloyloxyethyltrimethylammonium chloride (AETAC) copolymers.

16. Use according to any one of Claims 1 to 11, in which the flocculating water-soluble polymers are chosen from acrylamide/methacryloyloxyethyltrimethylammonium methyl sulfate copolymers or Polyquaternium-5 (INCI name).

17. Use according to any one of Claims 1 to

cationic celluloses, starches and galactomannan gums.

21. Use according to Claim 20, in which the cationic celluloses are chosen from cellulose ethers comprising quaternary ammonium groups, cationic
5 cellulose copolymers and celluloses grafted with a water-soluble quaternary ammonium monomer.

22. Use according to Claim 21, in which the cationic celluloses are quaternary ammoniums of hydroxycellulose that have reacted with an epoxide
10 substituted with a trimethylammonium.

23. Use according to Claim 21, in which the cationic celluloses are chosen from hydroxyalkylcelluloses grafted with a methacryloylethyltrimethyl-
ammonium, methacrylamidopropyltrimethylammonium or
15 dimethyldiallylammonium salt.

24. Use according to Claim 20, in which the cationic galactomannan gums are guar gums containing trialkylammonium cationic groups and more particularly guar gums modified with a 2,3-epoxypropyltrimethyl-
20 ammonium salt.

25. Use according to Claim 20, in which the cationic starches are starches modified with a 2,3-epoxypropyltrimethylammonium salt.

26. Use according to any one of Claims 1 to
25 25, in which the flocculating water-soluble polymer is present in amounts ranging from 0.1% to 50% and more

preferably from 1% to 20% by weight relative to the total weight of the composition.

27. Use according to any one of Claims 1 to 26, in a composition that is in the form of a lotion, a cream or a fluid gel distributed as an aerosol spray, in a pump-dispenser bottle or as a roll-on; in the form of a cream or gel distributed in a tube or grille; in the form of a stick.

28. Use according to any one of Claims 1 to 27, in an aerosol device consisting of:

(A) a container comprising a deodorant composition as defined according to any one of Claims 1 to 26;

(B) at least one propellant and a means for distributing the said aerosol composition.

29. Cosmetic process for treating human perspiration, which consists in applying to the surface of the skin an effective amount of a flocculating water-soluble polymer comprising amine groups borne by a side substituent directly attached to the main chain as defined according to any one of the preceding claims.

INTERNATIONAL SEARCH REPORT

International Application No
PCT/EP2005/005243

A. CLASSIFICATION OF SUBJECT MATTER IPC 7 A61K7/32				
According to International Patent Classification (IPC) or to both national classification and IPC				
B. FIELDS SEARCHED				
Minimum documentation searched (classification system followed by classification symbols) IPC 7 A61K				
Documentation searched other than minimum documentation to the extent that such documents are included in the fields searched				
Electronic data base consulted during the international search (name of data base and, where practical, search terms used) EPO-Internal, WPI Data, PAJ, EMBASE				
C. DOCUMENTS CONSIDERED TO BE RELEVANT				
Category °	Citation of document, with indication, where appropriate, of the relevant passages	Relevant to claim No.		
X	US 4 675 178 A (KLEIN WILLIAM L ET AL) 23 June 1987 (1987-06-23) column 2, lines 29-39; claims 1-3; examples 2-4,6,7	1,43-47		
X	EP 0 222 580 A (CALGON CORP) 20 May 1987 (1987-05-20) cited in the application the whole document	1,43-47		
X	EP 0 478 327 A (CALGON CORP) 1 April 1992 (1992-04-01) cited in the application the whole document	1,43-47		
----- -/--				
<input checked="" type="checkbox"/> Further documents are listed in the continuation of box C.				
<input checked="" type="checkbox"/> Patent family members are listed in annex				
° Special categories of cited documents				
<table style="width: 100%; border: none;"> <tr> <td style="width: 50%; border: none; vertical-align: top;"> *A* document defining the general state of the art which is not considered to be of particular relevance *E* earlier document but published on or after the international filing date *L* document which may throw doubts on priority claim(s) or which is cited to establish the publication date of another citation or other special reason (as specified) *O* document referring to an oral disclosure, use, exhibition or other means *P* document published prior to the international filing date but later than the priority date claimed </td> <td style="width: 50%; border: none; vertical-align: top;"> *T* later document published after the international filing date or priority date and not in conflict with the application but cited to understand the principle or theory underlying the invention *X* document of particular relevance; the claimed invention cannot be considered novel or cannot be considered to involve an inventive step when the document is taken alone *Y* document of particular relevance; the claimed invention cannot be considered to involve an inventive step when the document is combined with one or more other such documents, such combination being obvious to a person skilled in the art. *&* document member of the same patent family </td> </tr> </table>			*A* document defining the general state of the art which is not considered to be of particular relevance *E* earlier document but published on or after the international filing date *L* document which may throw doubts on priority claim(s) or which is cited to establish the publication date of another citation or other special reason (as specified) *O* document referring to an oral disclosure, use, exhibition or other means *P* document published prior to the international filing date but later than the priority date claimed	*T* later document published after the international filing date or priority date and not in conflict with the application but cited to understand the principle or theory underlying the invention *X* document of particular relevance; the claimed invention cannot be considered novel or cannot be considered to involve an inventive step when the document is taken alone *Y* document of particular relevance; the claimed invention cannot be considered to involve an inventive step when the document is combined with one or more other such documents, such combination being obvious to a person skilled in the art. *&* document member of the same patent family
A document defining the general state of the art which is not considered to be of particular relevance *E* earlier document but published on or after the international filing date *L* document which may throw doubts on priority claim(s) or which is cited to establish the publication date of another citation or other special reason (as specified) *O* document referring to an oral disclosure, use, exhibition or other means *P* document published prior to the international filing date but later than the priority date claimed	*T* later document published after the international filing date or priority date and not in conflict with the application but cited to understand the principle or theory underlying the invention *X* document of particular relevance; the claimed invention cannot be considered novel or cannot be considered to involve an inventive step when the document is taken alone *Y* document of particular relevance; the claimed invention cannot be considered to involve an inventive step when the document is combined with one or more other such documents, such combination being obvious to a person skilled in the art. *&* document member of the same patent family			
Date of the actual completion of the international search <p style="text-align: center; font-size: 1.2em;">25 July 2005</p>		Date of mailing of the international search report <p style="text-align: center; font-size: 1.2em;">29/08/2005</p>		
Name and mailing address of the ISA European Patent Office, P.B. 5818 Patentlaan 2 NL - 2280 HV Rijswijk Tel. (+31-70) 340-2040, Tx. 31 651 epo nl, Fax: (+31-70) 340-3016		Authorized officer <p style="text-align: center; font-size: 1.2em;">Yon, J-M</p>		

INTERNATIONAL SEARCH REPORT

International Application No
PCT/EP2005/005243

C.(Continuation) DOCUMENTS CONSIDERED TO BE RELEVANT		
Category °	Citation of document, with indication, where appropriate, of the relevant passages	Relevant to claim No
X	US 2002/119108 A1 (RIELEY HUGH ET AL) 29 August 2002 (2002-08-29) cited in the application the whole document -----	1,43-47
X	US 4 690 817 A (PHALANGAS CHARALAMBOS J ET AL) 1 September 1987 (1987-09-01) cited in the application the whole document -----	1,43-47

INTERNATIONAL SEARCH REPORT

International application No.
PCT/EP2005/005243

Box II Observations where certain claims were found unsearchable (Continuation of item 2 of first sheet)

This International Search Report has not been established in respect of certain claims under Article 17(2)(a) for the following reasons:

1. Claims Nos.:
because they relate to subject matter not required to be searched by this Authority, namely:

2. Claims Nos.: -
because they relate to parts of the International Application that do not comply with the prescribed requirements to such an extent that no meaningful International Search can be carried out, specifically:
see FURTHER INFORMATION sheet PCT/ISA/210

3. Claims Nos.:
because they are dependent claims and are not drafted in accordance with the second and third sentences of Rule 6.4(a).

Box III Observations where unity of invention is lacking (Continuation of item 3 of first sheet)

This International Searching Authority found multiple inventions in this international application, as follows:

1. As all required additional search fees were timely paid by the applicant, this International Search Report covers all searchable claims.

2. As all searchable claims could be searched without effort justifying an additional fee, this Authority did not invite payment of any additional fee.

3. As only some of the required additional search fees were timely paid by the applicant, this International Search Report covers only those claims for which fees were paid, specifically claims Nos.:

4. No required additional search fees were timely paid by the applicant. Consequently, this International Search Report is restricted to the invention first mentioned in the claims; it is covered by claims Nos.:

Remark on Protest

- The additional search fees were accompanied by the applicant's protest.
- No protest accompanied the payment of additional search fees.

FURTHER INFORMATION CONTINUED FROM PCT/ISA/ 210

Continuation of Box II.2

Claims Nos.: -

Present independent claims 1 and 29 relate to an extremely large number of possible compounds. Support within the meaning of Article 6 PCT and/or disclosure within the meaning of Article 5 PCT is to be found, however, for only a very small proportion of the compounds claimed. In the present case, the claims so lack support, and the application so lacks disclosure, that a meaningful search over the whole of the claimed scope is impossible. Consequently, the search has been carried out for those parts of the claims which appear to be supported and disclosed, namely those parts relating to the compounds prepared in the examples and those compounds mentioned in the description at pages 10 to 16.

The applicant's attention is drawn to the fact that claims relating to inventions in respect of which no international search report has been established need not be the subject of an international preliminary examination (Rule 66.1(e) PCT). The applicant is advised that the EPO policy when acting as an International Preliminary Examining Authority is normally not to carry out a preliminary examination on matter which has not been searched. This is the case irrespective of whether or not the claims are amended following receipt of the search report or during any Chapter II procedure. If the application proceeds into the regional phase before the EPO, the applicant is reminded that a search may be carried out during examination before the EPO (see EPO Guideline C-VI, 8.5), should the problems which led to the Article 17(2) declaration be overcome.

INTERNATIONAL SEARCH REPORT

Information on patent family members

International Application No

PCT/EP2005/005243

Patent document cited in search report		Publication date	Patent family member(s)	Publication date
US 4675178	A	23-06-1987	AU 589179 B2	05-10-1989
			AU 5708686 A	06-11-1986
			CA 1275051 A1	09-10-1990
			EP 0200548 A2	05-11-1986
			ZA 8603268 A	30-12-1986
EP 0222580	A	20-05-1987	AU 594093 B2	01-03-1990
			AU 6464986 A	07-05-1987
			EP 0222580 A1	20-05-1987
			JP 62108809 A	20-05-1987
EP 0478327	A	01-04-1992	AU 8483791 A	02-04-1992
			CA 2052432 A1	29-03-1992
			EP 0478327 A1	01-04-1992
			JP 5105798 A	27-04-1993
US 2002119108	A1	29-08-2002	AU 1910702 A	01-07-2002
			BR 0116691 A	21-10-2003
			CA 2430785 A1	27-06-2002
			CN 1482895 A	17-03-2004
			WO 0249590 A2	27-06-2002
			EP 1343462 A2	17-09-2003
			HU 0302849 A2	29-12-2003
			JP 2004517093 T	10-06-2004
			MX PA03005707 A	06-10-2003
			ZA 200304106 A	23-06-2004
US 4690817	A	01-09-1987	AR 242227 A1	31-03-1993
			AT 45751 T	15-09-1989
			AU 564745 B2	27-08-1987
			AU 3347984 A	18-04-1985
			BR 8405051 A	20-08-1985
			CA 1236639 A1	10-05-1988
			DE 3479504 D1	28-09-1989
			EP 0141269 A2	15-05-1985
			JP 60133008 A	16-07-1985
			MX 202910 A	28-02-1994
			NZ 209699 A	27-11-1987
			US 4645794 A	24-02-1987