



(22) Date de dépôt/Filing Date: 2004/03/19

(41) Mise à la disp. pub./Open to Public Insp.: 2005/09/19

(51) Cl.Int.⁷/Int.Cl.⁷ E21B 19/22

(71) Demandeur/Applicant:
DALLAS, L. MURRAY, US

(72) Inventeur/Inventor:
DALLAS, L. MURRAY, US

(74) Agent: OGILVY RENAULT LLP/S.E.N.C.R.L.,S.R.L.

(54) Titre : INJECTEUR DE TUBE DE PRODUCTION CONCENTRIQUE POUR L'INJECTION DE TUBES DE DIVERS DIAMETRES

(54) Title: COIL TUBING INFECTOR FOR INJECTING TUBINGS OF VARIOUS DIAMETERS

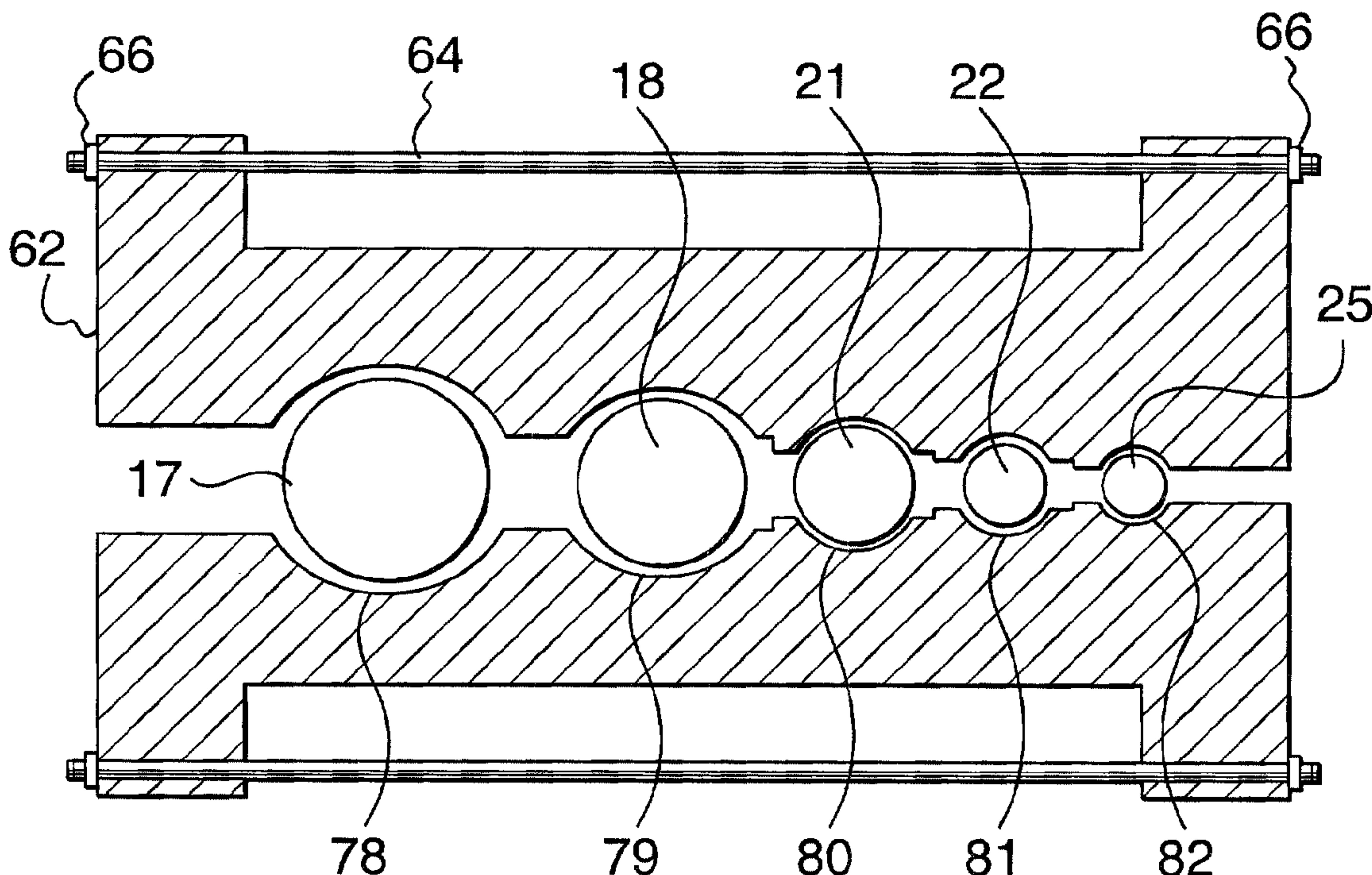

(57) Abrégé/Abstract:

A multi coil tubing injector includes a frame structure and a pair of gripper chain drives mounted to the frame structure. The pair of gripper chain drives are disposed in a common plane and spaced apart from each other, and have gripping blocks adapted to engage one or more of at least three differently-sized coil tubing strings to inject the coil tubing strings into, or extract them from, a subterranean well. The coil tubing injector assembly reduces a time required to perform many downhole operations, and therefore reduces a cost of well completion, stimulation and re-completion.

ABSTRACT OF THE DISCLOSURE

A multi coil tubing injector includes a frame structure and a pair of gripper chain drives mounted to the frame structure. The pair of gripper chain drives are
5 disposed in a common plane and spaced apart from each other, and have gripping blocks adapted to engage one or more of at least three differently-sized coil tubing strings to inject the coil tubing strings into, or extract them from, a subterranean well. The coil tubing injector
10 assembly reduces a time required to perform many downhole operations, and therefore reduces a cost of well completion, stimulation and re-completion.

COIL TUBING INJECTOR FOR INJECTING TUBINGS OF
VARIOUS DIAMETERS

TECHNICAL FIELD

The present invention relates generally to equipment
5 for performing downhole operations in subterranean wells.
More specifically, the invention relates to injectors for
injecting coil tubing strings of various diameters into
subterranean wells and for extracting the coil tubing
strings from the subterranean wells to perform well-
10 servicing operations.

BACKGROUND OF THE INVENTION

Continuous reeled tubing, generally known in the
energy industry as coil tubing string, has been used for
many years. It is rapidly gaining broad acceptance because
15 is much faster to run into and out of a well casing than
conventional jointed tubing.

Typically, the coil tubing string is inserted into the
wellhead through a lubricator assembly or stuffing box
because there is a pressure differential between an annulus
20 of the well and atmosphere, which may have been naturally
or artificially created. The pressure differential serves
to produce oil or gas, or a mixture thereof from the
pressurized well. A coil tubing string is run in and out
of a well bore using a coil tubing string injector, which
25 literally forces the coil tubing string into the well
through the lubricator assembly or stuffing box against the
well pressure until the weight of the coil tubing string
exceeds the force of the pressure acting against a cross-
sectional area of the coil tubing string. However, once the
30 weight of the coil tubing string overbears the well

pressure, it must be supported by the injector. The injection process is reversed as the coil tubing string is removed from the well.

The coil tubing string is relatively flexible and can therefore be wound onto and pulled off of a spool, or reel, by the injector, which often acts in concert with a windlass at a power supply that drives the spool, or reel. Conventionally, a coil tubing injector assembly utilizes a pair of opposed endless drive chains which are arranged in a common plane. These opposed endless drive chains are often referred to as gripper chains and carry a series of gripping blocks that are pressed against opposite sides of the coil tubing string, and thereby grip the coil tubing string. Each chain is stretched between a drive sprocket and an idle sprocket. At least one of the two drive sprockets is driven by a motor to turn one of the endless chains, to supply injection, retention or lifting force. The other drive sprocket may also be driven, typically by a second motor, to drive the second chain in order to provide extra power. Such coil tubing string injectors with various improvements are disclosed, for example, in U.S. Pat. No. 4,655,291, entitled INJECTOR FOR COUPLED PIPE, which issued to Cox on Apr. 7, 1987; U.S. Pat. No. 5,553,668, entitled TWIN CARRIAGE TUBING INJECTOR APPARATUS, which issued to Council et al. on Sep. 10, 1996; and U.S. Pat. No. 6,059,029, entitled COILED TUBING INJECTOR, which issued to Goode on May 9, 2000.

Another type of coil tubing string injector is disclosed in U.S. Pat. No. 5,566,764, entitled IMPROVED COIL TUBING INJECTOR UNIT which issued to Elliston on Oct. 22, 1996. Elliston describes a coil tubing string injector unit including a main injector frame having a longitudinal

opening that defines a vertical run for the injector unit, which can be aligned with the well bore's vertical axis. Elliston's injector unit has only one gripper chain drive system that carries plier-like halves that are pivotable
5 between an open position and a closed, gripping position as the gripper chain enters the vertical run, so that the plier halves grip a selected length of a coil tubing string fed into the main injector frame along the central vertical axis of the injector unit to inject the coil tubing string
10 into the well bore.

United States. Pat. No. 4,474,236, entitled METHOD AND APPARATUS FOR REMOTE INSTALLATION OF DUAL TUBING STRINGS IN A SUBSEA WELL, which issued to Kellett on Oct. 2, 1984, discloses a method and apparatus for completing a well
15 having production and service strings of different sizes. The method includes steps of running the production tubing string on a main tubing string hanger and maintaining control with a variable bore blowout preventer, and then running the service string into the main tubing string
20 hanger while maintaining control using a dual bore blowout preventer.

Injector assemblies that are capable of injecting dual tubing strings are also known in the prior art. The Applicant's U.S. Patent No. 6,516,891 (Dallas), which
25 issued on Feb. 11, 2003, discloses a coil tubing injector assembly that is capable of injecting dual string coil tubing into a well bore simultaneously, either synchronously or asynchronously.

Although the Applicant has invented an apparatus for
30 injecting and extracting two tubing strings, there does not exist, to the best of the Applicant's knowledge, any

apparatus or method for the injection and extraction of tubing strings of several different diameters.

As is understood by those skilled in the art, coil tubing is available in a variety of sizes and the size of tubing used for production, well treatment or other special purpose depends on factors that are not always known in advance. It is also common knowledge that the size of coil tubing installed in a well bore or to be installed in the well bore is not invariably correctly communicated to the service provider responsible for injection or extraction of the coil tubing.

As a consequence, services providers must stock a plurality of coil to be injectors which require a considerable capital investments and an extensive parts inventor for maintenance. In addition, if the wrong injector is delivered to a job site, costly delays are incurred while the appropriate injector is being delivered. Such delays increase the cost of hydrocarbon production and are desirably avoided.

Thus, there exists a need for a method and apparatus for injecting and extracting tubing strings of various diameters into or from a subterranean well.

SUMMARY OF THE INVENTION

It is therefore an object of the invention to provide a coil tubing injector that can be used to selectively inject any of one or more of a plurality of differently-sized coil tubing strings into a well bore, or to extract the one or more coil tubing strings from the well bore.

The invention therefore provides a coil tubing injector assembly including a frame structure for mounting

above a wellhead; and at least one gripper chain drive system mounted to the frame structure and having a plurality of opposed gripping blocks adapted to grip any one of at least three differently-sized coil tubing strings for injecting and extracting the coil tubing strings into and from a subterranean well.

The invention further provides a method of injecting or extracting one of at least three differently-sized coil tubing strings into or from a subterranean well using a single coil tubing injector, including the steps of gripping one of the at least three differently-sized coil tubing strings with one of at least three differently-sized gripping surfaces formed on gripping blocks attached to opposed gripper chains; and driving the opposed gripper chains at substantially the same angular velocity in opposite rotational directions to inject or extract one of the at least three coil tubing strings into or from the well.

BRIEF DESCRIPTION OF THE DRAWINGS

Further features and advantages of the present invention will become apparent from the following detailed description, taken in combination with the appended drawings, in which:

FIG. 1 is a schematic side elevation view of a coil tubing injector assembly mounted to a wellhead of a subterranean well in accordance with one embodiment of the invention, the injector assembly being capable of injecting and extracting into and from the well any one or more of four coil tubing strings of various diameters;

FIG. 2 is a schematic front elevation view of a first embodiment of the invention in which a single gripper chain drive system is used to inject and extract any one or more of four differently-sized coil tubing strings;

5 FIG. 3 is a schematic front elevation view of a second embodiment of the invention, in which four independent gripper chain drive systems are used to inject and extract any one or more of four differently-sized coil tubing strings;

10 FIG. 4 is a side elevation view of a gripper chain drive system;

FIG. 5 is a cross-sectional view of a pair of gripping blocks, or "skates", for use in the first embodiment of the coil tubing injector assembly shown in FIG. 2;

15 FIG. 5a is a cross-sectional view of four pairs of gripping blocks, or "skates", for use in the second embodiment of the coil tubing injector assembly shown in FIG. 3;

20 FIG. 6 is a cross-sectional view of a pair of gripping blocks, or "skates", for use in injecting and extracting any one of five differently-sized coil tubing strings;

25 FIG. 6a is a cross-sectional view of five pairs of gripping blocks, or "skates", for use in injecting and extracting any one of five differently-sized coil tubing strings;

FIG. 7 is a cross-sectional view of a pair of gripping blocks, or skates, for use in injecting and extracting any one of three differently-sized coil tubing strings;

FIG. 7a is a cross-sectional view of three pairs of gripping blocks, or skates, for use in injecting and extracting any one of three differently-sized coil tubing strings;

5 FIG. 8 is a cross-sectional view of a common drive shaft for driving four gripper chain drives;

FIG. 9 is a cross-sectional view of four independent drive shafts for independently driving four gripper chain drives; and

10 FIG. 10 is a schematic cross-sectional diagram illustrating a method of using the multi coil tubing injector to inject four coil tubing strings into a well, either sequentially, as pairs, or all together where one coil tubing string at each production zone is used for
15 delivery of a well treatment fluid, such as a surfactant, while the other is used for the production of hydrocarbon.

It will be noted that throughout the appended drawings, like features are identified by like reference numerals.

20 DETAILED DESCRIPTION OF PREFERRED EMBODIMENTS

FIGS. 1 and 2 schematically illustrate a coil tubing injector assembly in accordance with the present invention, generally indicated by reference numeral 10. The coil tubing injector is positioned above a wellhead 12, and may
25 be supported by the wellhead 12, or on a ground surface 14, in a manner well known in the art. A lubricator or stuffing box 16 is connected to a top end of the wellhead 12 to contain well pressure while coil tubing and/or downhole tools is/are run into or out of the well, as will be
30 explained below in more detail.

The coil tubing injector 10 may be used to inject any one or more of four differently-sized coil tubing strings into a well. A first coil tubing string 17 is supplied from a reel 19. A second coil tubing string 18 is supplied from a second reel 20. A third coil tubing string 21 is supplied from a third reel 23. A fourth coil tubing string 22 is supplied from a fourth reel 24. Each of the coil tubing strings has a different diameter, as illustrated. Although each coil tubing string is usually injected or extracted one at a time, it is also possible to synchronously or asynchronously inject or extract two or more coil tubing strings. As noted above, dual injection of coil tubing strings is disclosed in Applicant's U.S. Patent No. 6,516,891 which issued on Feb. 11, 2003 and is hereby incorporated by reference.

Each of the coil tubing strings is typically several thousand feet in length. The four coil tubing strings 17, 18, 21, 22 are in a coiled state as they are supplied from their respective reels 19, 20, 23, 24. The coil tubing strings are spooled from their respective reels, which are normally supported on trucks (not shown) to provide mobility.

The coil tubing injector assembly 10 includes a frame structure 26, which may be constructed in any number of ways well known in the art. Extending upwardly from the frame structure 26 is a coil tubing guide framework 28 (shown in FIG. 1) that supports a plurality of rotatably mounted guide rollers 30 and 32 that guide the respective coil tubings 17, 18, 21, 22 into the tubing injector. The coil tubing strings are run between respective sets of rollers 30 and 32, as better seen in FIG. 2. As the coil tubing strings are unspooled from their respective reels,

their length is generally measured by respective measuring devices, such as measuring wheels 33, 34, 35, 36 or the like. Alternatively, one or more measuring device(s) may be incorporated into the coil tubing injector assembly 10, in
5 a manner well known in the art.

The rollers 30 and 32, which are supported by the framework 28, define four pathways for each of the four coil tubing strings 17, 18, 21, 22 so that any curvature in the coil tubing strings coming off the reels 19, 20, 23, 24
10 is slowly straightened as the coil tubing strings enter the coil tubing injector assembly 10. The respective sets of rollers 30 and 32 are spaced apart so that straightening of the coil tubing is accomplished as the coil tubing strings are inserted into the well by a gripper chain drive system
15 37 which has a pair of substantially identical gripper chain drives 38 spaced apart from one another and disposed opposite each other in a common plane. The coil tubing strings 17, 18, 21, 22 pass through the coil tubing injector assembly 10 and are securely supported in the grip
20 of the pair of spaced gripper chain drives 38, which include gripper blocks that are forced against each of the coil tubing strings 17, 18, 21, 22 to frictionally engage the respective coil tubing strings. The gripper chain drives 38 are driven by means of pressurized hydraulic
25 fluid, for example, in a direction to move the coil tubing strings into or out of the well, as required. Pressurized hydraulic fluid may also be used to power a pressure mechanism for gripping or releasing the coil tubing strings as will be explained below in further detail.

30 FIG. 2 is a front elevation view of the coil tubing injector assembly 10 in accordance with the first embodiment of the invention. The coil tubing guide

framework 28 includes adjacent coil tubing guides 29a, 29b, 29c, 29d which are preferably interconnected by the coil tubing guide framework 28, though interconnection of coil tubing guides 29a, 29b, 29c, 29d is not required. The coil tubing guide 29a straightens coil tubing 17 as it is fed between the gripper chain drives 38 of the gripper chain drive system 37. The coil tubing guide 29b straightens coil tubing 18 in the same way. Likewise, coil tubing guides 29c and 29d straighten coil tubing strings 21 and 22, respectively. The multi coil tubing injector assembly 10 uses a plurality of substantially identical gripping blocks, each having multiple gripping surfaces, as will be explained below in greater detail.

As depicted in FIG. 3, a second embodiment of the multi coil tubing injector assembly 10a has four gripper chain drive systems 37a, 37b, 37c, 37d, each of which includes a pair of opposed, substantially identical gripper chain drives 38. Each of the four gripper chain drive systems is independently operable. The multi coil tubing injector 10a uses differently-sized gripping blocks, each having a single gripping surface, as will also be described below in more detail.

FIG. 4 is a side elevation view of the gripper chain drive system 37. The gripper chain drive system 37 has two opposed gripper chain drives 38 which are spaced apart to accommodate a length of tubing string between the gripper chain drives 38. By rotating in opposite directions, the opposed gripper chain drives 38 cooperate to grip tubing strings and to inject or extract the tubing strings from a well. In FIG. 4, only the first coil tubing string 17 is visible (because the smaller diameter tubing strings 18,

21, 22 are obstructed from view behind the first coil tubing string 17).

Each gripper chain drive system 37 is driven by a hydraulic motor 52 preferably connected to a transmission which ensures that each opposed pair of gripper chain drives 38 moves at the same rate but in opposite directions. As shown in FIG. 4, each gripper chain drive 38 includes a gripper chain 42 which is driven by the drive sprocket 44 mounted to a drive shaft 46. The drive sprocket 44 and drive shaft 46 are connected to hydraulic motors 52 through transmissions (not shown). An idle sprocket 48 is mounted to an idle shaft 50 and engages the lower loop of the gripper chain 42. The pair of drive shafts 46 are rotatably mounted to the frame structure 26 (FIG. 1). The idle shafts 50 are pivotally mounted to the frame structure 26 by means of a tensioner to provide adjustment of the tension of the gripper chains 42, using any one of several tensioning systems well known in the art.

As shown in FIG. 4, inside each of the gripper chains 42 is a roller chain 84. The roller chain 84 is built up from rollers connected together by links and pins, in a well-known manner. The roller chain 84 rolls freely about a periphery of a pressure beam 86 and is supported by a pair of sprockets 88 and 90, which are rotatably connected to the pressure beam 86.

The pressure beams 86 are movable toward and away from each other. When the pressure beams 86 are moved toward each other, each pressure beam 86 exerts a force against its roller chain 84 and the roller chain 84 bears against the gripper chain 42 to force it against the coil tubing strings 17, 18, 21, 22. Thus, when the pressure beams 86

are forced inwardly toward each other, the coil tubing strings 17, 18, 21, 22 are gripped between the gripper chains 42. The gripping force is dependent upon the force with which the pressure beams 86 are pressed against the roller chain 84 by the actuators 92, which may be hydraulic cylinders, for example. The pressure beams 86 are provided with trunnions 94, the ends of which are slidable within slots in the frame structures (not shown) so that the pressure beams 86 are supported by the frame structures and movable with respect to the frame structure. The trunnions 94 are connected to the respective actuators 92 which are also supported by the frame structure (not shown) so that the pressure beams 86 are controlled to exert the gripping force.

In a first embodiment of the invention, there is only a single gripper chain drive system for each gripper chain 42, and a plurality of substantially identical gripping blocks 62 on each opposed gripper chain 42. In another embodiment, each gripper chain drive system 38 has a plurality of gripping blocks 62 that are different from the gripping blocks 62 of the other gripper chain drive systems of the coil tubing injector 10.

As shown in FIG. 4, each of the gripper chains 42 includes a plurality of links 66 that interconnect the coil tubing gripping blocks 62. Each gripping block 62, has a size and shape adapted to grip a least one coil tubing string. Each of the coil tubing gripping blocks 62 includes a pair of pins 64 that connect the links 66 to the coil tubing string gripping block 62 and engage teeth of the sprockets 46, 48. The adjacent coil tubing string gripping blocks 62 are interconnected by link members 66 to form an endless chain loop as shown in FIG. 4. In order to

grip one of the coil tubing strings, each gripping block 62 has at least one gripping surface.

Illustrated in FIG. 5 is a pair of opposed gripping blocks 62 that cooperate to inject and extract any one of four coil tubing strings, each having a different diameter. The gripping block 62 has a first gripping surface 78, a second gripping surface 79, a third gripping surface 80 and a fourth gripping surface 81 which are shaped to grip, respectively, the first tubing string 17, the second tubing string 18, the third tubing string 21 and the fourth tubing string 22. As illustrated in FIG. 5, the four gripping surfaces 78, 79, 80, 81 have rounded contours and are sized to accommodate any one of four standard-size tubing strings each having a different diameter. The gripping surfaces may be coated with a non-slip material to increase the coefficient of static friction.

FIG. 5a illustrates four differently-sized pairs of gripping blocks for use with the second embodiment introduced with reference to FIG. 3. In this second embodiment, each of the four gripper chain drive systems 37a, 37b, 37c, 37d has its own set of substantially identical gripping blocks 62a, 62b, 62c, 62d. The four gripping blocks 62a, 62b, 62c, 62d have contoured gripping surfaces 78, 79, 80, 81 for gripping the four coil tubing strings 17, 18, 21, 22, respectively.

In a further embodiment, the coil tubing injector 10 has a plurality of substantially identical gripping blocks 62 that are capable of gripping any one of five coil tubing strings. In this embodiment, the coil tubing injector has a single gripper chain drive system for injection and extraction of the coil tubing strings.

FIG. 6 shows an opposed pair of gripping blocks 62 having five gripping surfaces sized and shaped to grip any one of five tubing strings having different diameters. Each gripping block 62 has five contoured gripping surfaces 5 78, 79, 80, 81 and 82 which are capable of gripping any one of five coil tubing strings 17, 18, 21, 22, 25.

In yet another embodiment of the invention, the coil tubing injector has five independent gripper chain drive systems. Each gripper chain drive system has its own set of 10 substantially identical gripping blocks arranged in opposed pairs. Any one of five coil tubing strings can therefore be injected or extracted by driving the corresponding gripper chain drive system.

FIG. 6a illustrates five differently-sized pairs of 15 opposed gripping blocks 62a, 62b, 62c, 62d, 62e which are mounted to five respective gripper chain drive systems (not shown). The five sets of gripping blocks can be used to inject or extract any one or more of five differently-sized coil tubing strings 17, 18, 21, 22, 25 into or from a well, 20 either synchronously or asynchronously.

In another embodiment, the coil tubing injector has a single gripper chain drive system capable of injecting or extracting any one or more of three coil tubing strings. The gripper chain drive system employs a plurality of 25 opposed gripping blocks having three gripping surfaces.

As illustrated in FIG. 7, each gripping block 62 has three differently-sized, contoured gripping surfaces 78, 79, 80 which are capable of gripping three coil tubing strings 17, 18, 21 of different diameter. When the gripper 30 chain drive system is driven, any one or more of three coil

tubing strings can be injected into or extracted from the well.

In a further embodiment, the coil tubing injector has three independent gripper chain drive systems for injecting or extracting of any one or more of three differently-sized coil tubing strings. Each of the three gripper chain drive systems has its own differently-sized set of gripping blocks.

As shown in FIG. 7a, the gripping blocks 62a, 62b, 62c have gripping surfaces 78, 79, 80, respectively, for gripping any one of three coil tubing strings 17, 18, 21. When one or more coil tubing strings are to be injected or extracted, the gripper chain drive system(s) is driven independently of other two gripper chain drive systems that are not in use.

Persons skilled in the art will appreciate that the coil tubing injector in accordance with the present invention could be designed and constructed to handle more than five tubing strings at a time. The number of coil tubing strings that may be inserted or extracted is dependent on the number of gripping surfaces on the gripping blocks 62.

In a further embodiment, the differently-sized sets of gripping blocks that were illustrated in FIG. 5a, 6a and 7a (which have only one gripping surface), may be mounted to a common drive shaft such as shown in FIG. 8. Recalling, with regard to FIG. 4, that two opposed gripper chain drives constitute a gripper chain drive system, the mechanism shown in FIG. 8 therefore represents only one of the two sides of the gripper chain drive system. As noted above, in order to inject or extract a coil tubing string,

two opposed common drive shafts must rotate with substantially the same angular velocity but in opposite rotational directions. Therefore, the common drive shafts may be driven by separate motors or by a common motor
5 having suitable gearing to rotate the opposed drive shafts at the same angular velocity but in opposite rotational directions.

As shown in FIG. 8, a common drive shaft 46 has four drive sprockets 44 that are secured to the common drive
10 shaft by respective keys 45. The common drive shaft 46 is supported at one end by a bearing 47, such as a roller bearing, which is secured in a bore in the frame structure 26. A transmission output sprocket 49, which may also be a gear, is also connected by a key 45 (or a spline) to the
15 drive shaft 46. The transmission output sprocket 49 is connected via a transmission (not shown) to the hydraulic motor 52. The hydraulic motor turns the drive shaft 46 about axis x by exerting a torque T_x on the drive shaft via the transmission and transmission output sprocket.

20 In operation, the four drive sprockets 44 engage respective gripper chains 42 for injecting any one or more of four differently-sized coil tubing strings into or extending them from the well. Although FIG. 8 shows four drive sprockets, persons skilled in the art will appreciate
25 that the common drive shaft could accommodate a different number of drive sprockets, such as three or five.

FIG. 9 shows a drive mechanism for a coil tubing injector in accordance with the invention having four gripper chain drive systems, such as the one shown in
30 FIG. 3. Each of the four gripper chain drive systems has a pair of opposed gripper chain drives. Each pair of gripper

chain drives has one of four differently-sized sets of gripping blocks 62, such as those illustrated in FIG. 5a, for injecting or extracting one or more of four coil tubing strings. Each gripper chain is driven via a separate
5 drive sprocket 44a-44d.

As shown in FIG. 9, the four drive sprockets 44a-44d (which drive respective gripper chains that are not shown) are mounted on four independent drive shafts 46a-46d. The drive sprockets 44a-44d are mounted to respective drive
10 shafts 46a-46d by means of keys 45 so that the drive sprockets are rotated together with the drive shafts. Four transmission output sprockets 49a-49d are connected by keys 45 to their respective drive shafts 46a-46d. Each transmission output sprocket 49a-49d may be driven by an
15 independent hydraulic motor and transmission. Alternatively, one motor may be used to drive more than one of the transmission output sprockets by suitable gearing permits torque to be delivered to more than one output sprocket. As shown in FIG. 9, each of the four drive
20 shafts 46a-46d run on a pair of roller bearings 47, which are secured at opposite ends of each drive shaft 46a-46d in bores in the frame structure 26 (FIG.1). The four independently drivable shafts 46a-46d permit the synchronous or asynchronous injection or extraction of any
25 one or more of four differently-sized coil tubing strings.

In summary, the coil tubing injector in accordance with the invention enables a user to inject or extract one or more of a number of differently-sized coil tubing strings. Consequently, only one or more tubing injectors
30 have to be kept in stock and the probability that an appropriate coil tubing injector is delivered to a job site is greatly improved. The coil tubing injector therefore

significantly reduces overhead, minimizes rig downtime and helps control the overall cost of hydrocarbon extraction.

FIG. 10 illustrates one of many possible applications of the coil tubing injector in which four differently-sized coil tubing injectors are injected sequentially or together using the synchronous or asynchronous injectors described above. The first and second coil tubing strings 17, 18 are injected into the vicinity of a first production zone 100. The third and fourth coil tubing strings 21, 22 are injected into the vicinity of a second production zone 200. A plug or packer 150 is typically inserted between the first and second production zones to ensure pressure isolation in a manner well known in the art. The first coil tubing string 17 is used to inject a well treatment fluid, such as a surfactant, into the first production zone 100 while the second coil tubing string 18 is used for production of hydrocarbons from the first production zone. Likewise, the third coil tubing string 21 is used to inject a well treatment fluid into the second production zone 200, while the fourth coil tubing string 22 is used for production from the second production zone.

Persons skilled in the art will readily appreciate that the coil tubing injector in accordance with the present invention is adapted to facilitate and expedite many other types of downhole operations in which time is saved by sequentially or synchronously injecting and/or extracting any one of a number of coil tubing strings using the same injector. The application shown in FIG. 10 is therefore intended to be exemplary only. It should also be understood that although the invention has been described with reference to coil tubing injectors for injecting a plurality of coil tubing strings of different diameters,

two or more of the gripping surfaces of each gripping block 62 could be sized to grip the same size of tubing.

The embodiments of the invention and the uses of the invention described are illustrative but not comprehensive
5 of the configurations and uses to which the invention is adapted. The scope of the invention is therefore intended to be limited solely by the scope of the appended claims.

WHAT IS CLAIMED IS:

1. A coil tubing injector assembly comprising:
a frame structure for mounting above a wellhead; and
at least one gripper chain drive system mounted to the frame structure and having a plurality of opposed gripping blocks adapted to grip at least one of at least three differently-sized coil tubing strings for injecting the coil tubing strings into and extracting the coil tubing strings from a subterranean well.
2. The assembly as claimed in claim 1 wherein each gripping block comprises at least one gripping surface adapted to grip one of the plurality of coil tubing strings.
3. The assembly as claimed in claim 2 wherein the gripping surface is concave.
4. The assembly as claimed in claim 3 comprising a single gripper chain drive system having a pair of opposed gripper chain drives, each gripper chain drive including a plurality of substantially identical gripping blocks.
5. The assembly as claimed in claim 4 wherein the gripping blocks have at least three gripping surfaces.
6. The assembly as claimed in claim 5 wherein each gripping block has three differently-sized gripping

surfaces for gripping at least one of three differently-sized coil tubing strings.

7. The assembly as claimed in claim 5 wherein each gripping block has four differently-sized gripping surfaces for gripping at least one of four differently-sized coil tubing strings.
8. The assembly as claimed in claim 5 wherein each gripping block has five differently-sized gripping surfaces for gripping at least one of five differently-sized coil tubing strings.
9. The assembly as claimed in claim 3 comprising at least three independently drivable gripper chain drive systems, each gripper chain drive system having a pair of opposed gripper chain drives, each gripper chain drive system having a plurality of substantially identical gripping blocks.
10. The assembly as claimed in claim 9 wherein each gripping block has a single gripping surface.
11. The assembly as claimed in claim 10 comprising three gripper chain drive systems each having a differently-sized gripping surface.
12. The assembly as claimed in claim 10 comprising four gripper chain drive systems each having a differently-sized gripping surfaces.
13. The assembly as claimed in claim 10 comprising five gripper chain drive systems each having a differently-sized gripping surface.

14. The assembly as claimed in claim 1 wherein the at least one gripper chain drive system comprises a pair of opposed gripper chain drives, each gripper chain drive having a drive sprocket mounted to a drive shaft, each drive shaft being coupled to a motor whereby the drive shafts of the opposed gripper chain drives are rotated at a same angular velocity but in opposite rotational directions.
15. The assembly as claimed in claim 14 wherein each gripper chain drive further comprises:
an idle sprocket mounted to an idle shaft; and
a gripper chain engaged with the drive sprocket and the idle sprocket, the gripper chain having the gripping blocks attached around an outer periphery of the gripper chain.
16. The assembly as claimed in claim 15 wherein each gripper chain drive further comprises a pressure beam supported by the frame structure and movable with respect to the frame structure, the pressure beam being adapted to support the gripper chains while the gripper chains grip the coil tubing string.
17. The assembly as claimed in claim 16 further comprising a roller chain system operatively mounted to the pressure beam for reducing friction between the pressure beam and the gripper chain.
18. The assembly as claimed in claim 17 wherein the pressure beam is connected to an actuator mounted to the frame structure for moving the pressure beam.

19. A method of injecting or extracting one of at least three differently-sized coil tubing strings into or from a subterranean well using a single coil tubing injector, comprising the steps of:
- gripping at least one of the at least three differently-sized coil tubing strings with at least one of at least three differently-sized gripping surfaces formed on gripping blocks attached to opposed gripper chains; and
- driving the opposed gripper chains at substantially the same angular velocity in opposite rotational directions to inject or extract the at least one of the at least three coil tubing strings into or from the well.
20. The method as claimed in claim 19 further comprising a step of actuating pressure beams to force the gripping surfaces of the gripper chains against the at least one of the at least three coil tubing strings.

OGILVY RENAULT
1981 McGill College Avenue
Suite 1600
Montreal, Quebec, Canada H3A 2Y3

Patent Agents for Applicants.

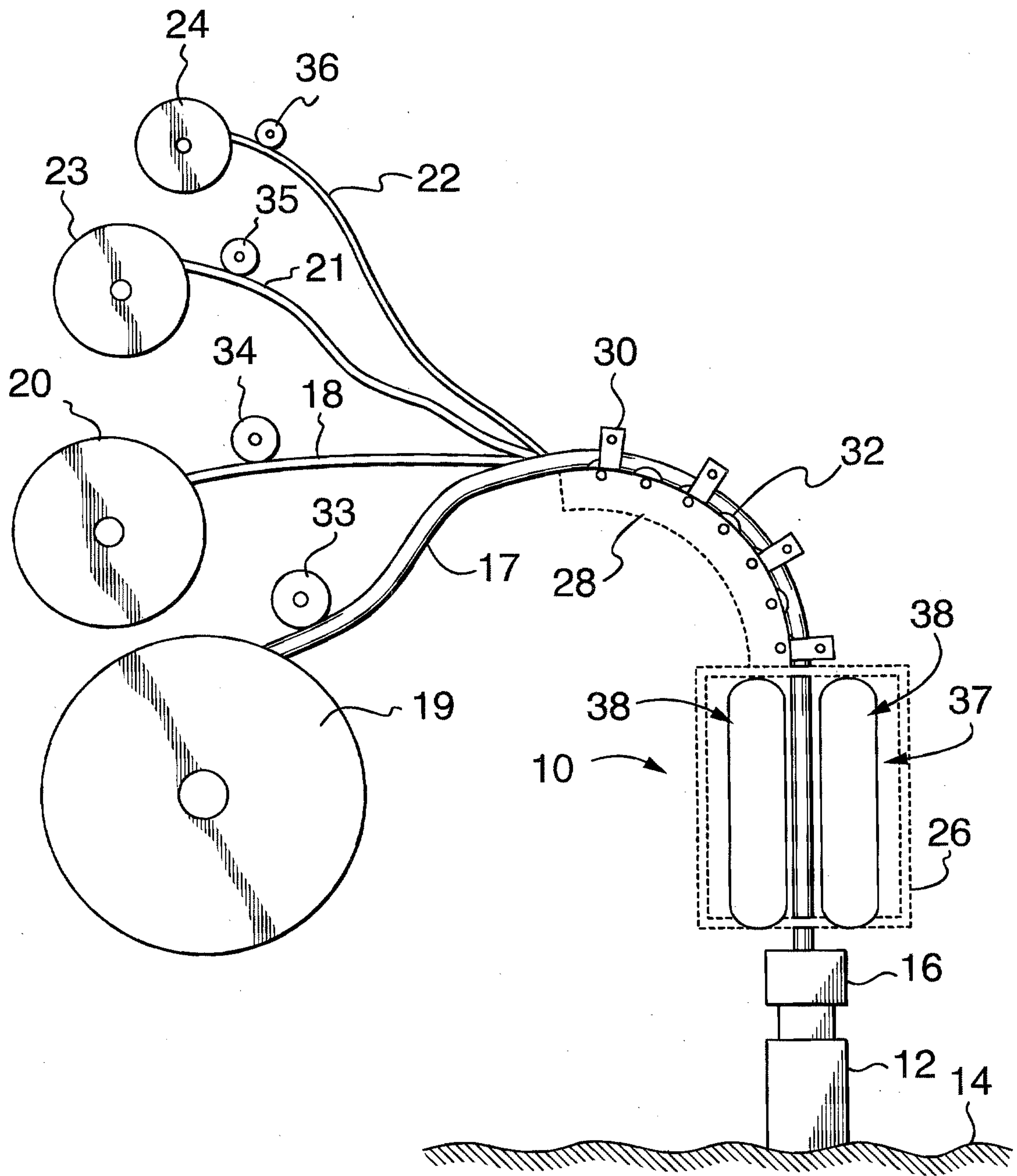

FIG. 1

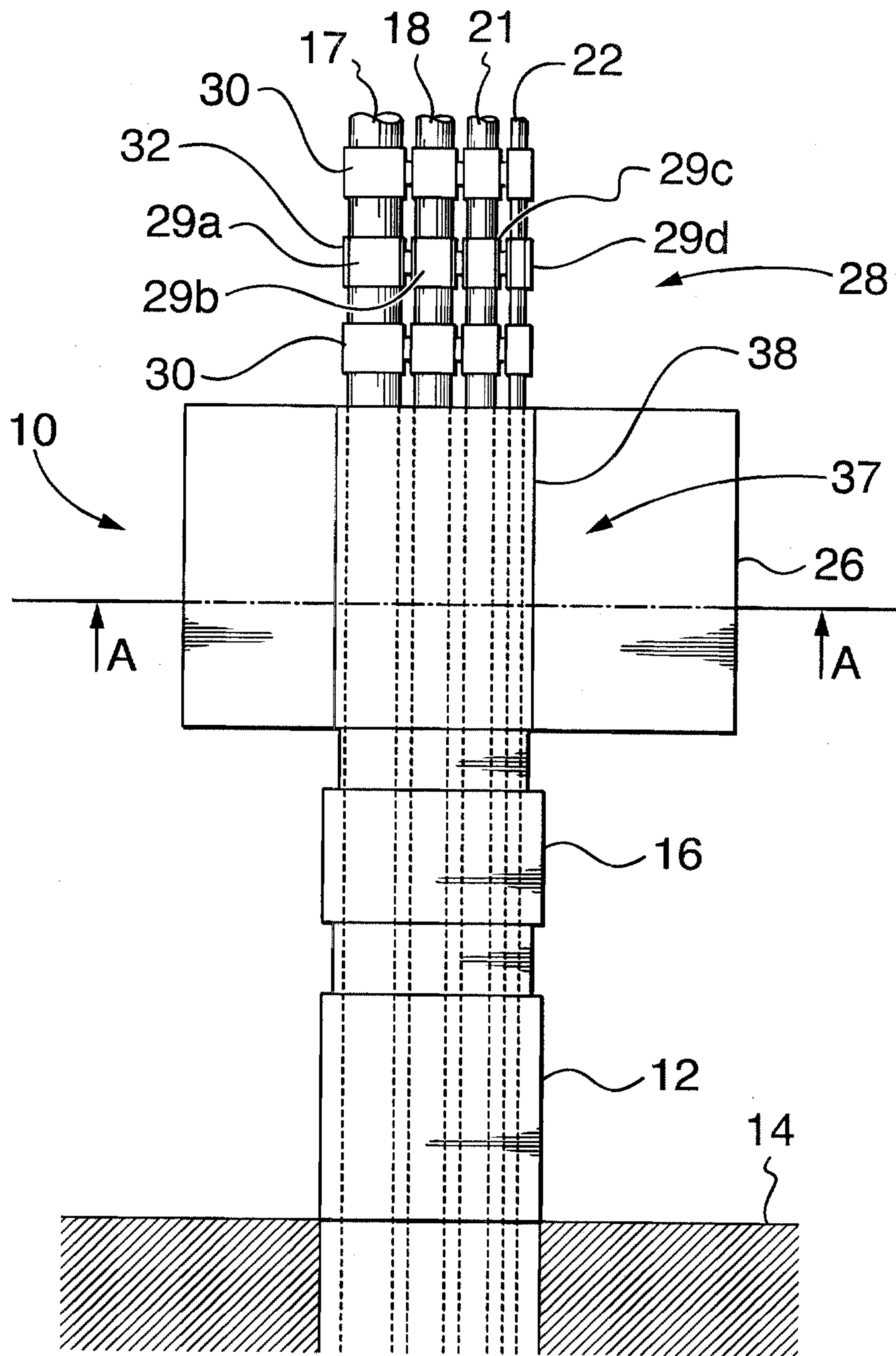

FIG. 2

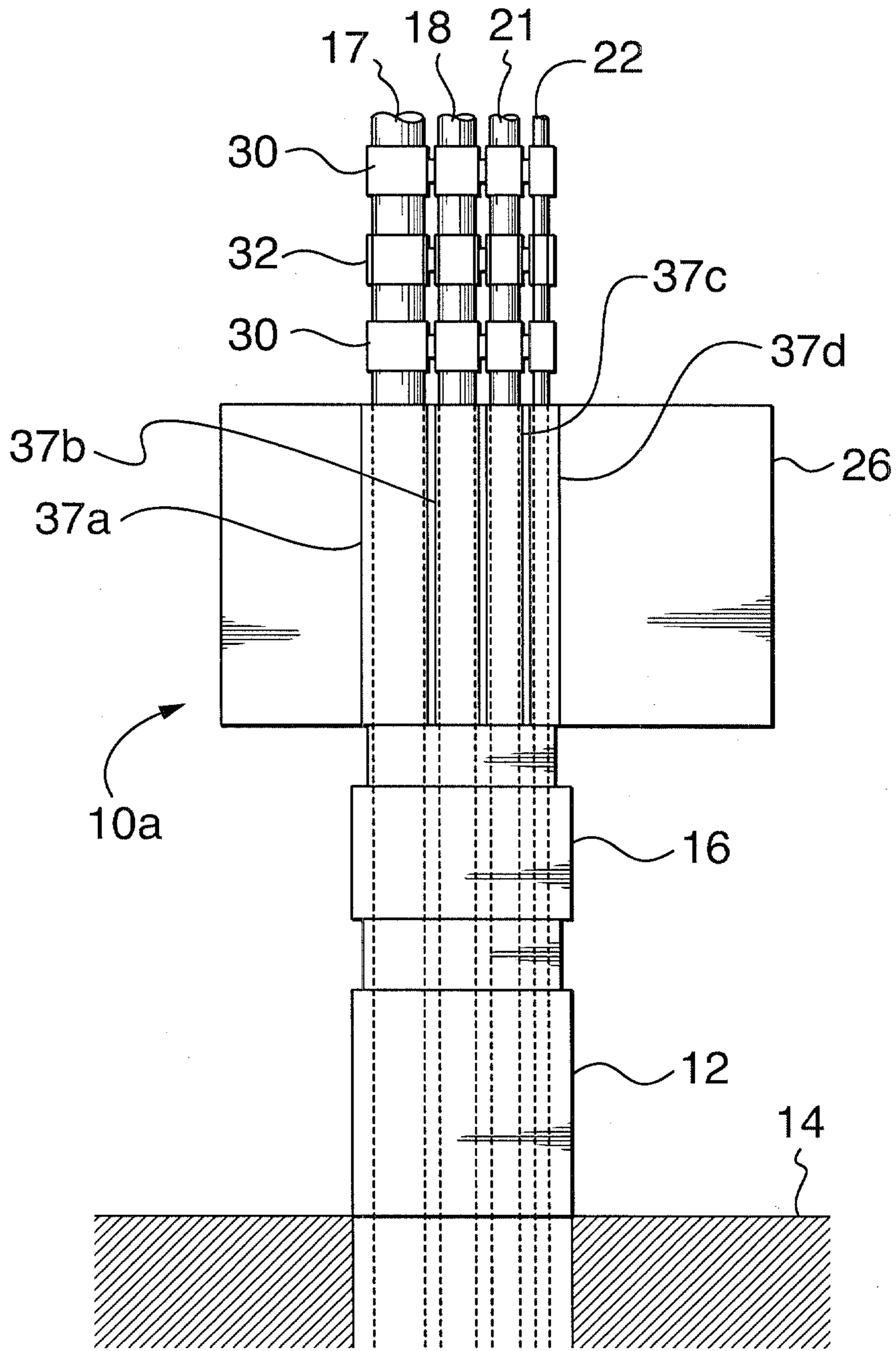

FIG. 3

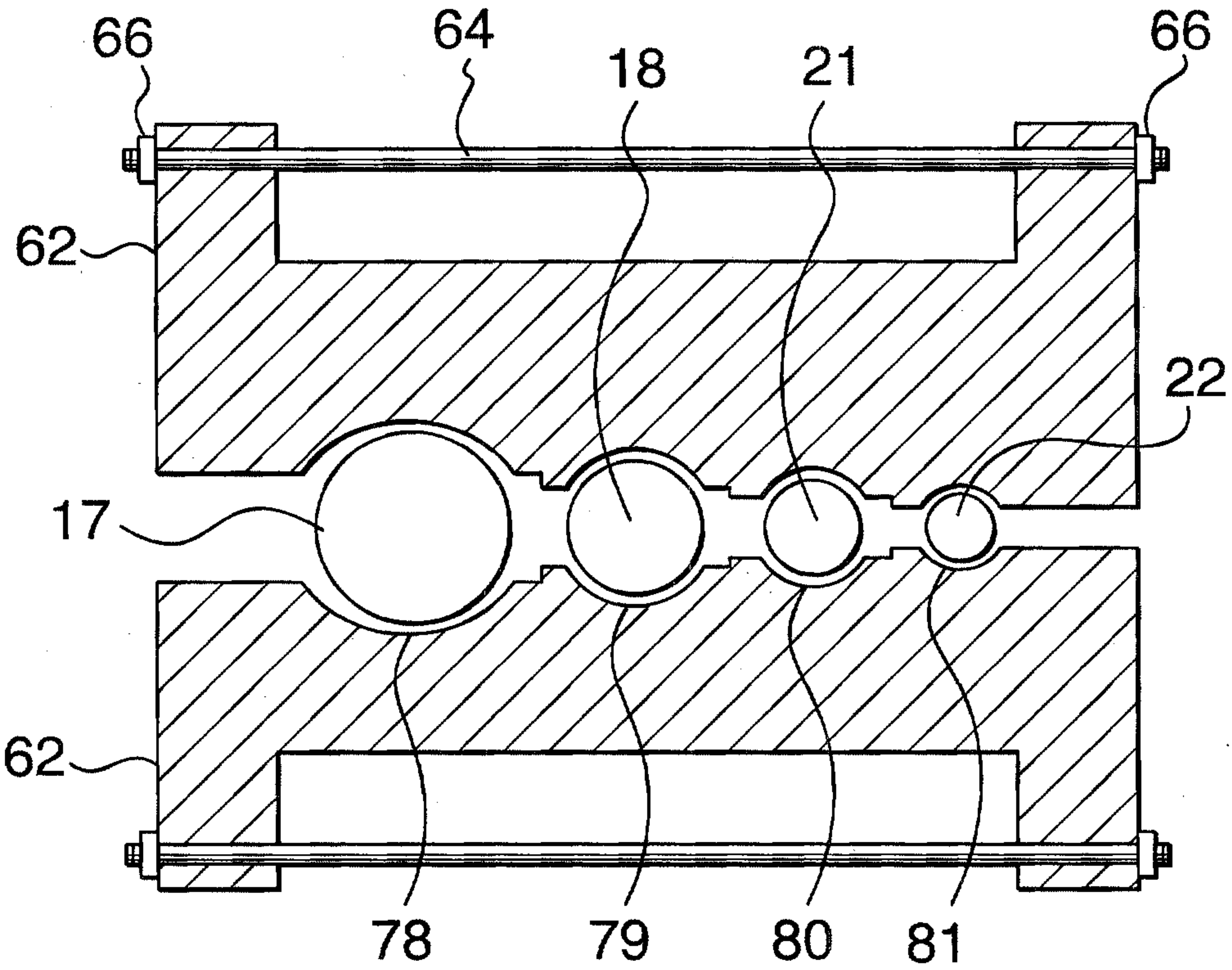

FIG. 5

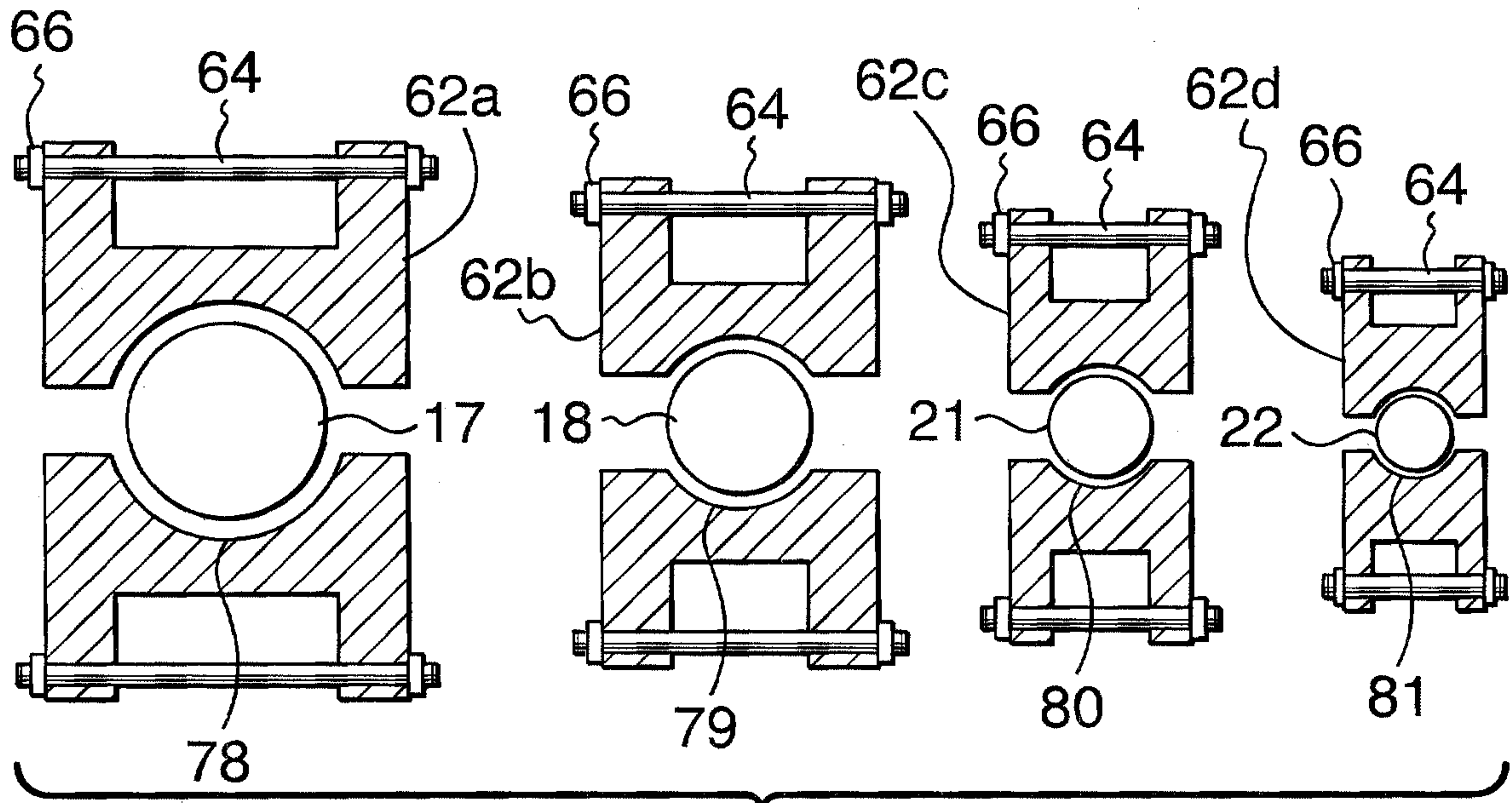

FIG. 5a

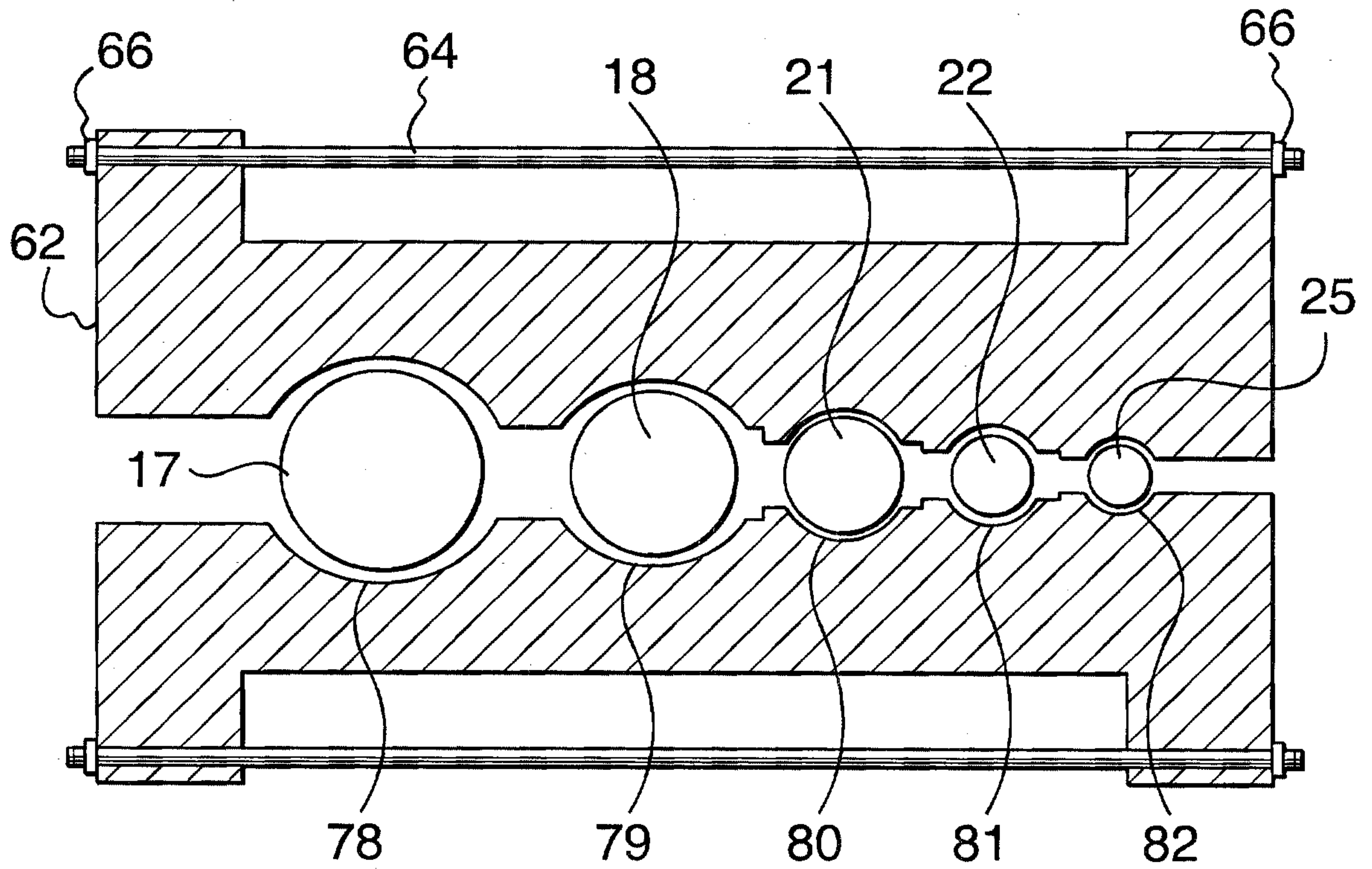

FIG. 6

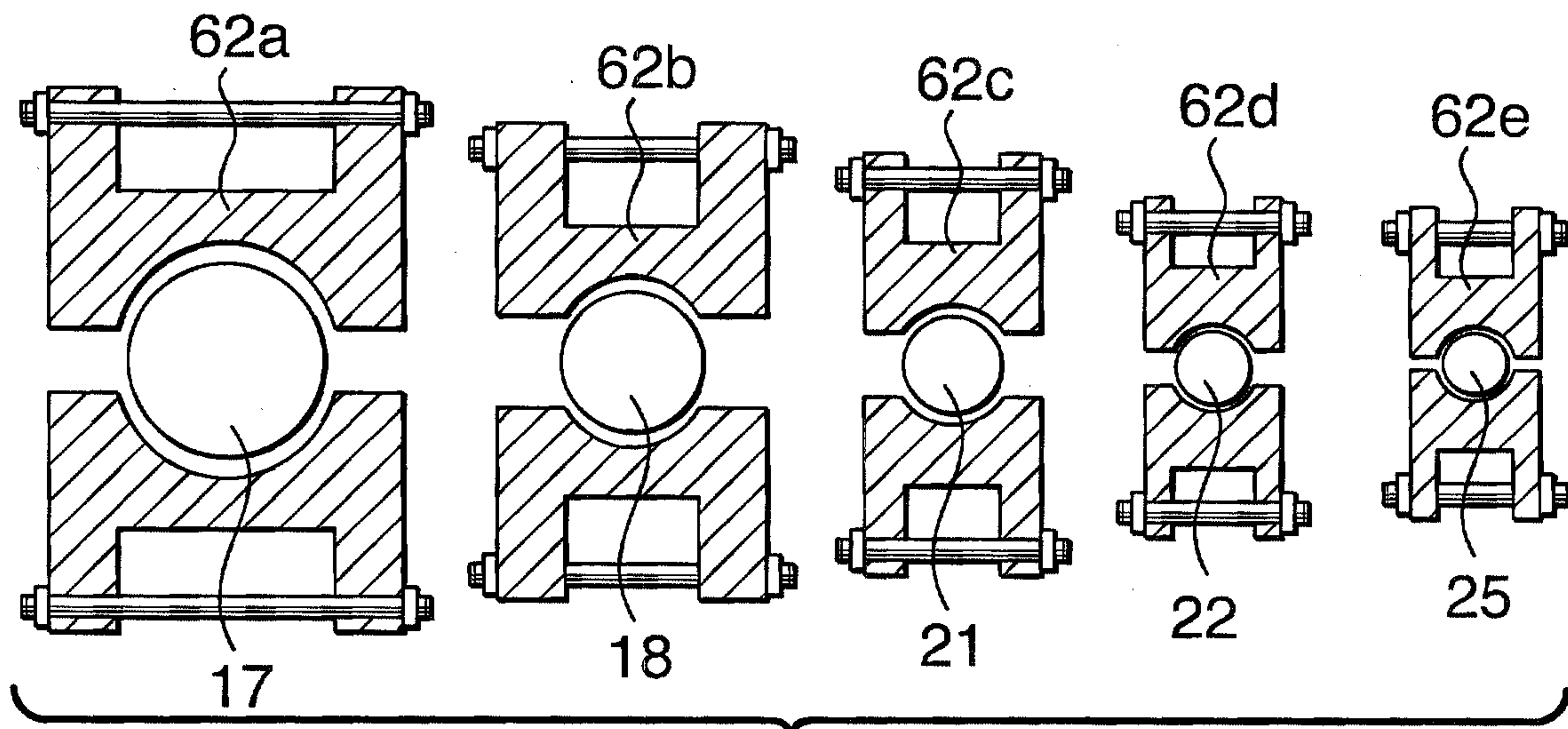

FIG. 6a

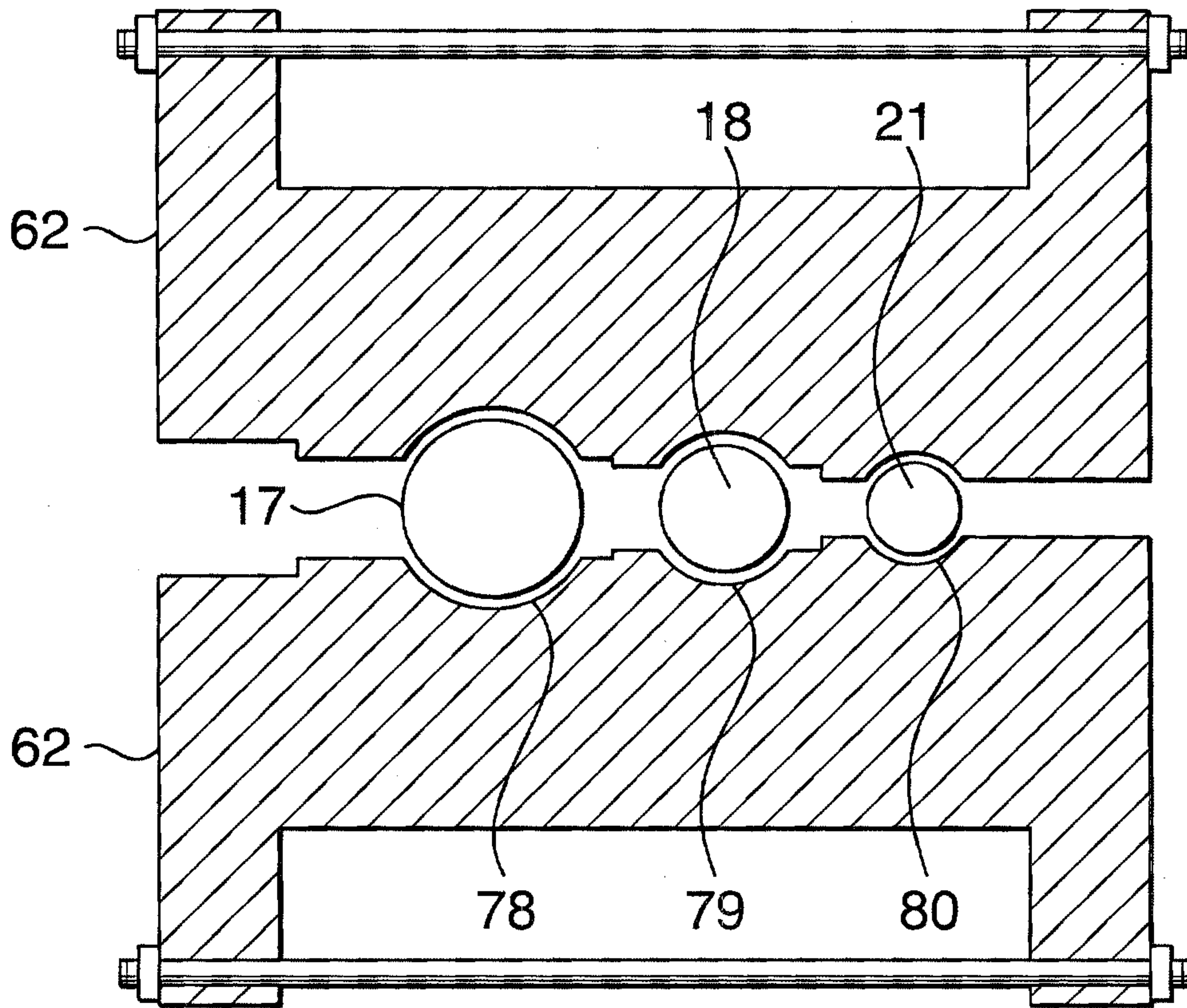

FIG. 7

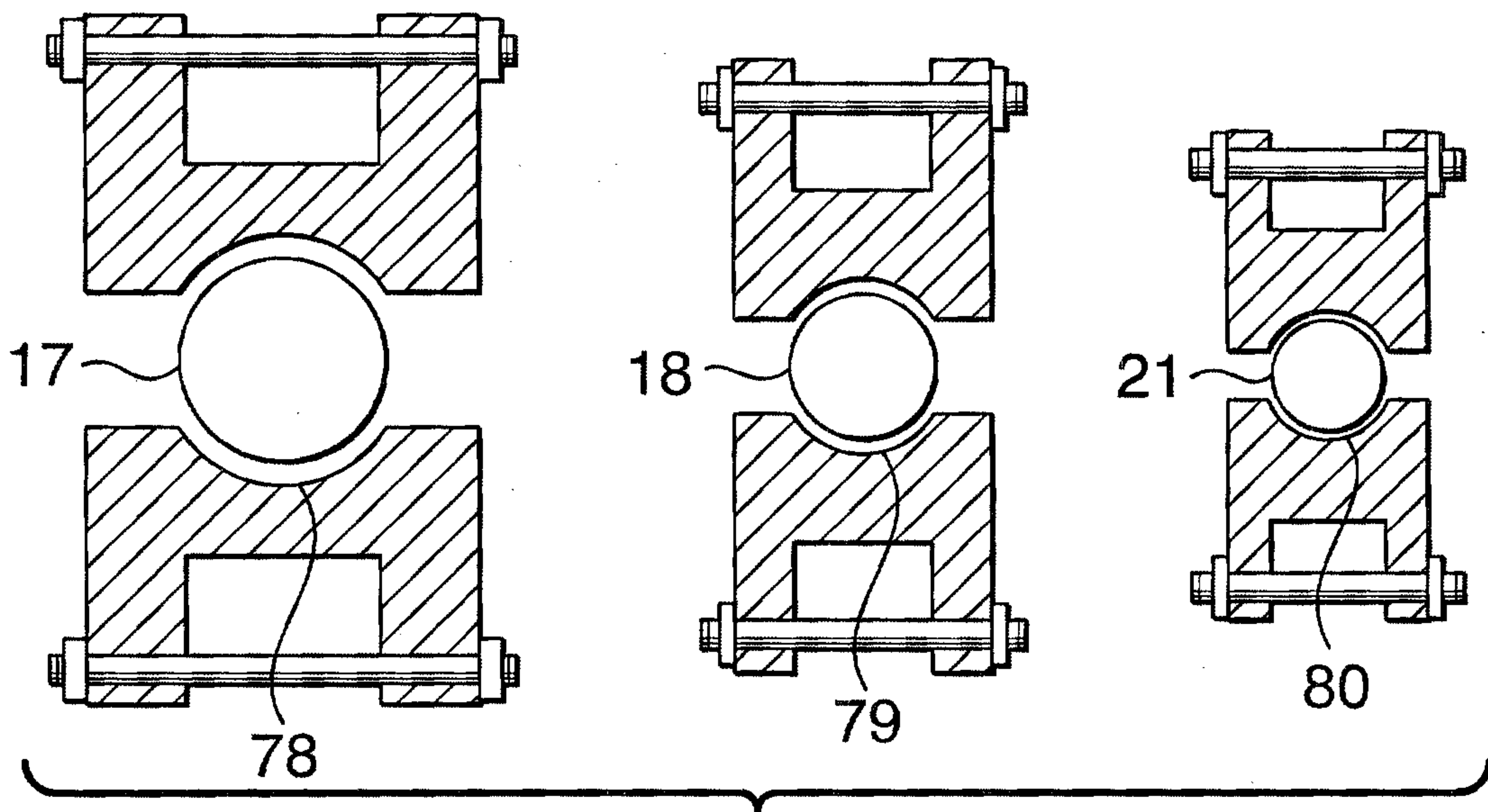

FIG. 7a

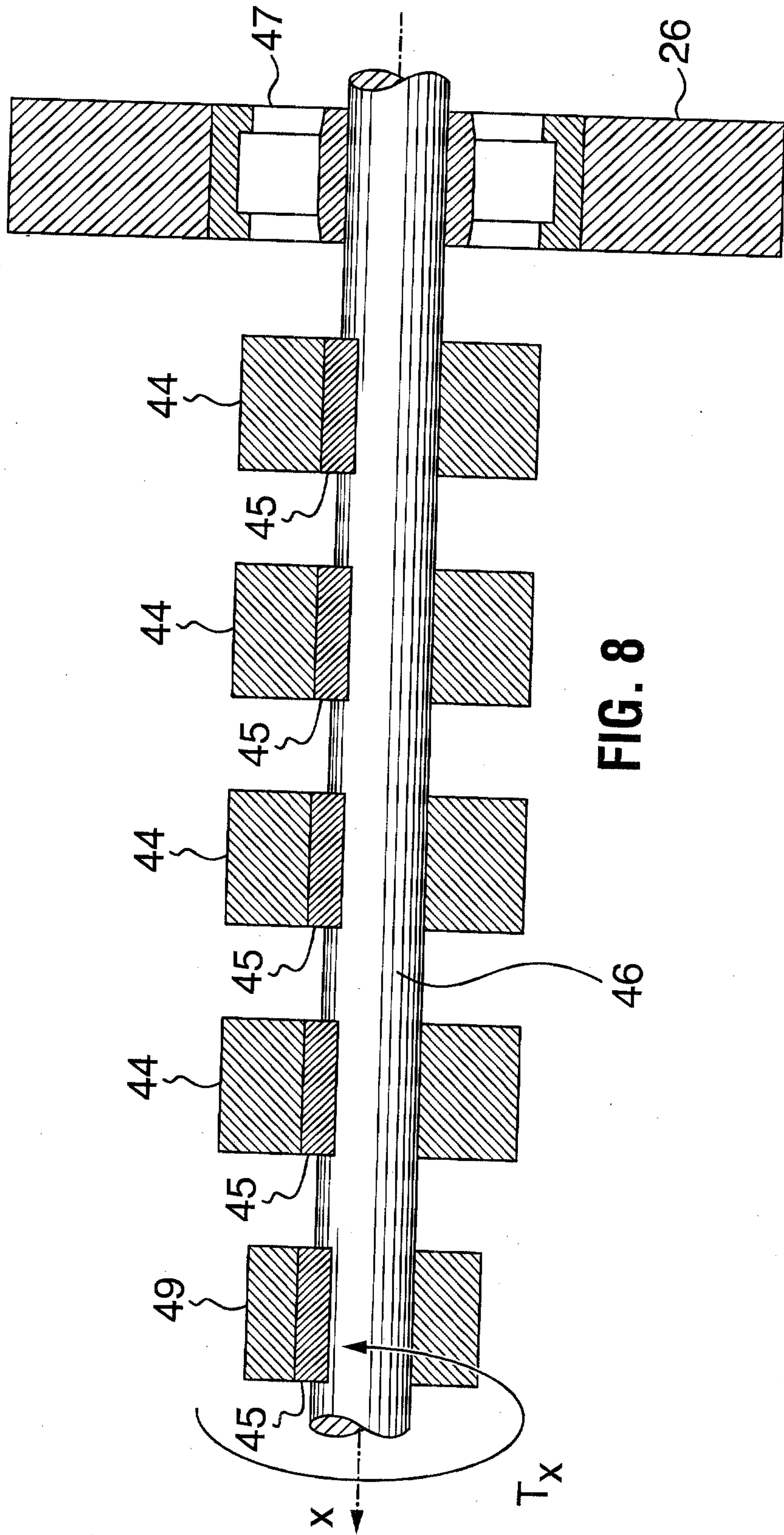

FIG. 8

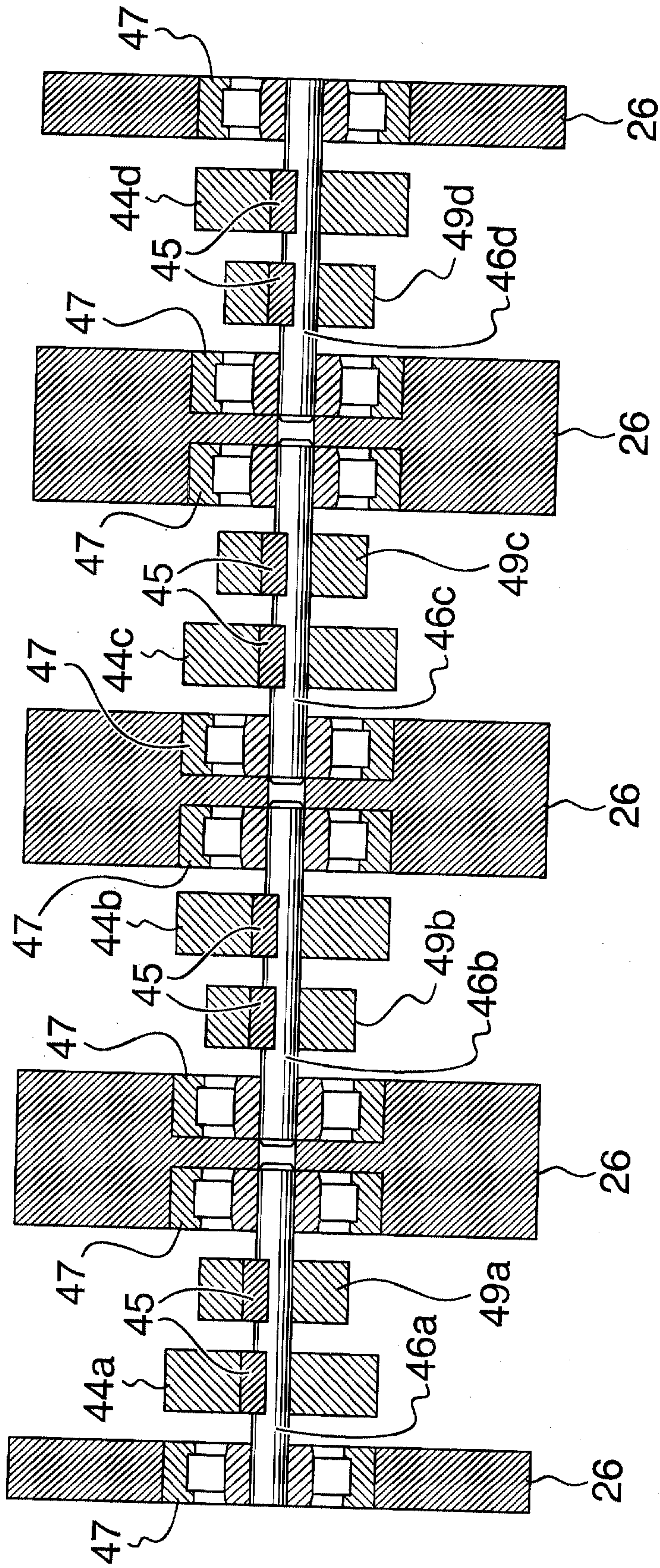

FIG. 9

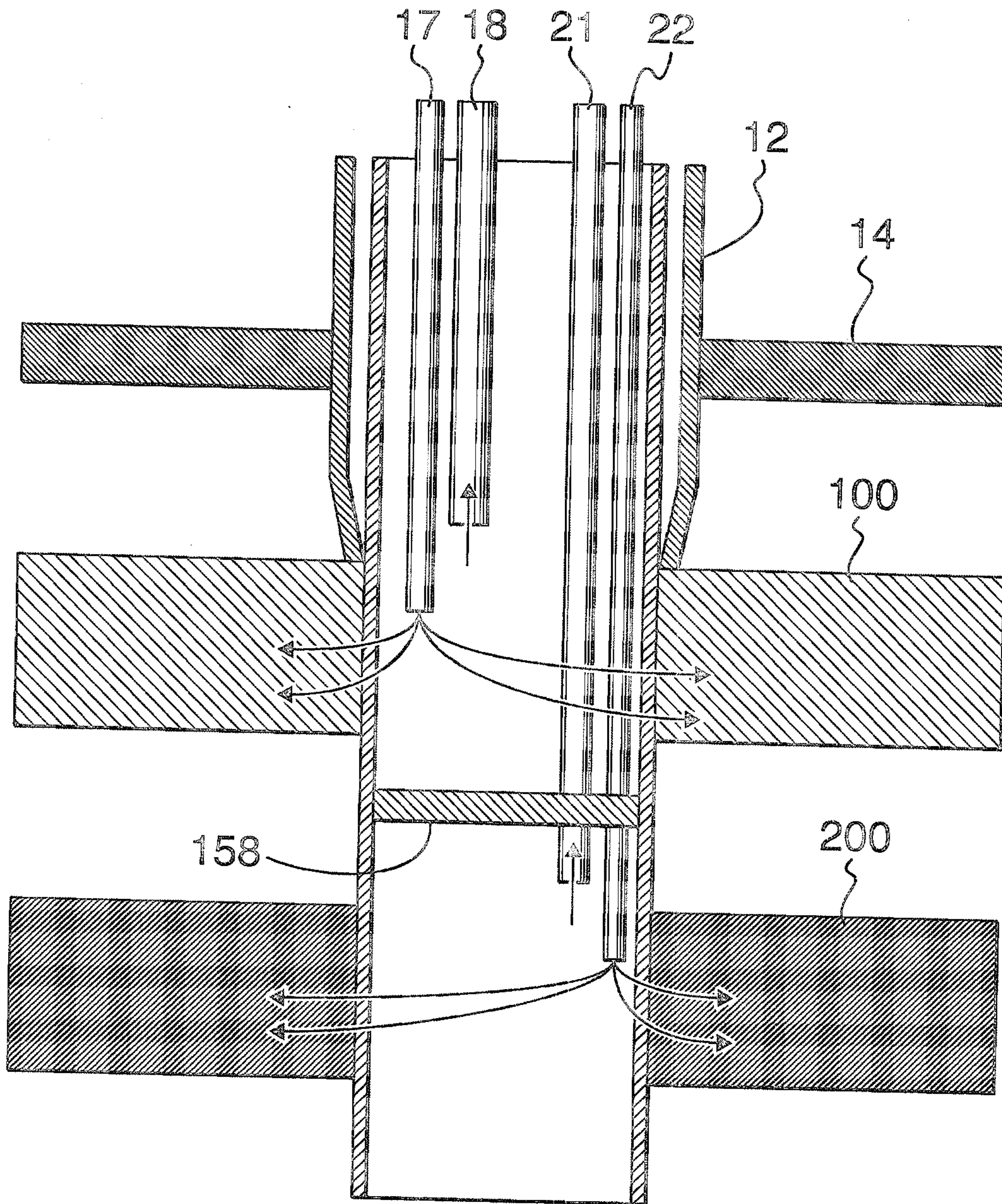

FIG. 10

