

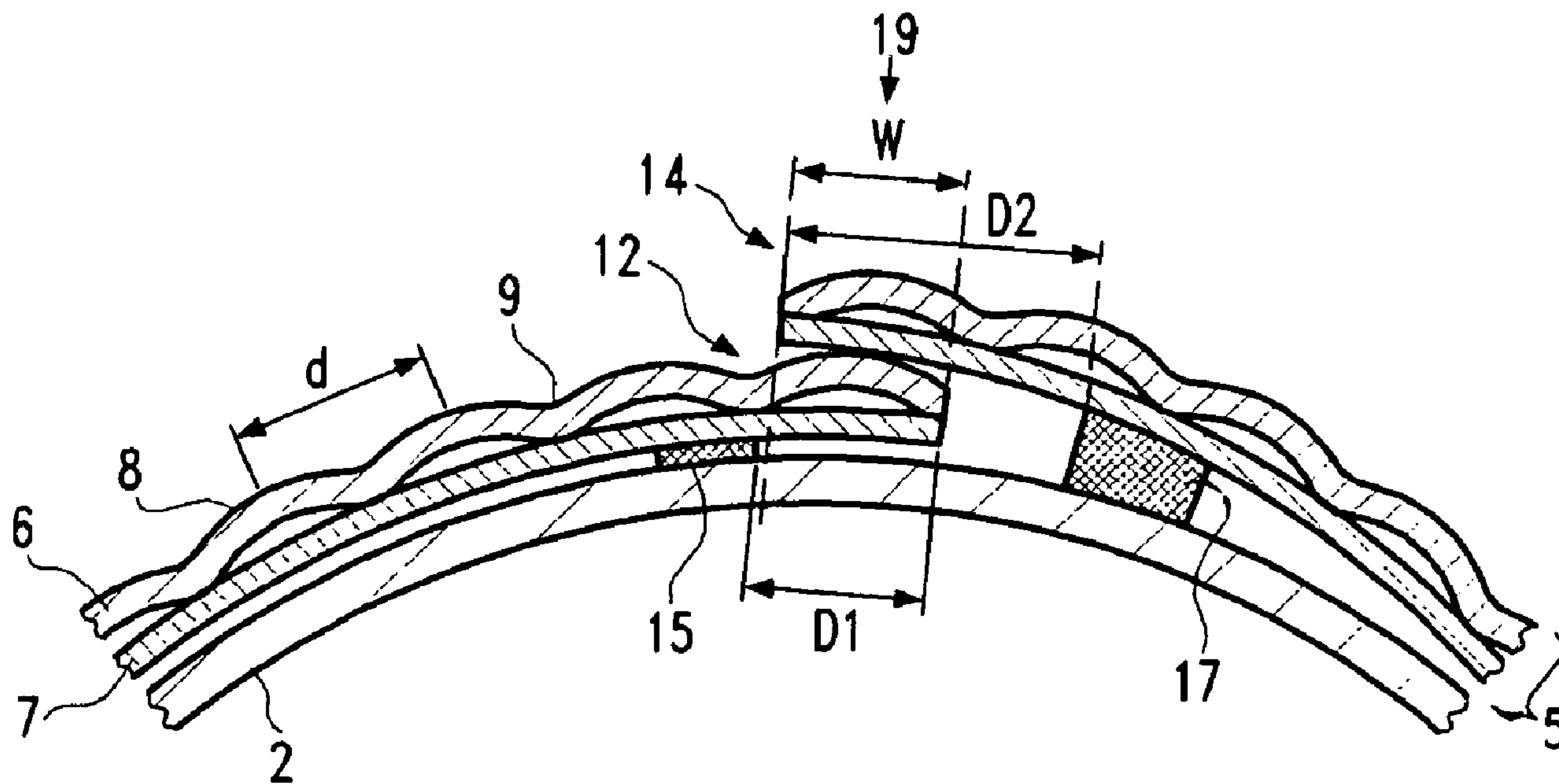

(86) Date de dépôt PCT/PCT Filing Date: 2006/11/09  
 (87) Date publication PCT/PCT Publication Date: 2007/05/18  
 (85) Entrée phase nationale/National Entry: 2008/05/09  
 (86) N° demande PCT/PCT Application No.: EP 2006/010767  
 (87) N° publication PCT/PCT Publication No.: 2007/054318  
 (30) Priorité/Priority: 2005/11/11 (EP05024667.7)

(51) Cl.Int./Int.Cl. *B65D 81/38* (2006.01),  
*B65D 21/02* (2006.01)  
 (71) Demandeur/Applicant:  
SEDA S.P.A., IT  
 (72) Inventeur/Inventor:  
D'AMATO, GIANFRANCO, IT  
 (74) Agent: ROBIC

(54) Titre : GOBELET ISOTHERME  
 (54) Title: INSULATED CUP



(57) Abrégé/Abstract:

Cup (1) with an internal wall (2) and an external sleeve (5), the sleeve being formed from a blank (10) of corrugated material comprising a corrugated layer (6) and a Substrate layer (7) and being arranged such that the Substrate layer (7) faces towards the internal wall of the cup. A first end (12) of the blank (10) is overlapped at least partially by a second end (14) of the blank in an overlapping area (19). Further, the sleeve (5) is adhesively attached to the internal wall of the cup (1) at least by a first area (15) of adhesive being provided on an inner side of the sleeve on the first end of the blank and by a second area (17) of adhesive being provided on an inner side of the sleeve on the second end of the blank. The second area (17) of adhesive is provided at a distance from the overlapping edge (13) of the blank, thereby attaching each end of the blank (10) separately to the internal wall of the cup (1).

## (12) INTERNATIONAL APPLICATION PUBLISHED UNDER THE PATENT COOPERATION TREATY (PCT)

(19) World Intellectual Property Organization  
International Bureau



(43) International Publication Date  
18 May 2007 (18.05.2007)

PCT

(10) International Publication Number  
**WO 2007/054318 A1**

## (51) International Patent Classification:

*B65D 81/38* (2006.01)      *B65D 21/02* (2006.01)

## (21) International Application Number:

PCT/EP2006/010767

## (22) International Filing Date:

9 November 2006 (09.11.2006)

## (25) Filing Language:

English

## (26) Publication Language:

English

## (30) Priority Data:

05024667.7      11 November 2005 (11.11.2005)      EP

(71) Applicant (for all designated States except US): **SEDA S.P.A.** [IT/IT]; Corso Salvatore d'Amato 84, I-80022 Arzano Napoli (IT).

## (72) Inventor; and

(75) Inventor/Applicant (for US only): **D'AMATO, Gianfranco** [IT/IT]; Corso Salvatore d'Amato 84, I-80022 Arzano Napoli (IT).

(74) Agent: **ROTHAEMEL, Bernd**; Grünecker, Kinkeldey, Stockmair & Schwanhäusser, Maximilianstrasse 58, 80538 München (DE).

(81) Designated States (unless otherwise indicated, for every kind of national protection available): AE, AG, AL, AM, AT, AU, AZ, BA, BB, BG, BR, BW, BY, BZ, CA, CH, CN, CO, CR, CU, CZ, DE, DK, DM, DZ, EC, EE, EG, ES, FI, GB, GD, GE, GH, GM, GT, HN, HR, HU, ID, IL, IN, IS, JP, KE, KG, KM, KN, KP, KR, KZ, LA, LC, LK, LR, LS, LT, LU, LV, LY, MA, MD, MG, MK, MN, MW, MX, MY, MZ, NA, NG, NI, NO, NZ, OM, PG, PH, PL, PT, RO, RS, RU, SC, SD, SE, SG, SK, SL, SM, SV, SY, TJ, TM, TN, TR, TT, TZ, UA, UG, US, UZ, VC, VN, ZA, ZM, ZW.

(84) Designated States (unless otherwise indicated, for every kind of regional protection available): ARIPO (BW, GH, GM, KE, LS, MW, MZ, NA, SD, SL, SZ, TZ, UG, ZM, ZW), Eurasian (AM, AZ, BY, KG, KZ, MD, RU, TJ, TM), European (AT, BE, BG, CH, CY, CZ, DE, DK, EE, ES, FI, FR, GB, GR, HU, IE, IS, IT, LT, LU, LV, MC, NL, PL, PT, RO, SE, SI, SK, TR), OAPI (BF, BJ, CF, CG, CI, CM, GA, GN, GQ, GW, ML, MR, NE, SN, TD, TG).

## Published:

— with international search report

For two-letter codes and other abbreviations, refer to the "Guidance Notes on Codes and Abbreviations" appearing at the beginning of each regular issue of the PCT Gazette.

(54) Title: INSULATED CUP

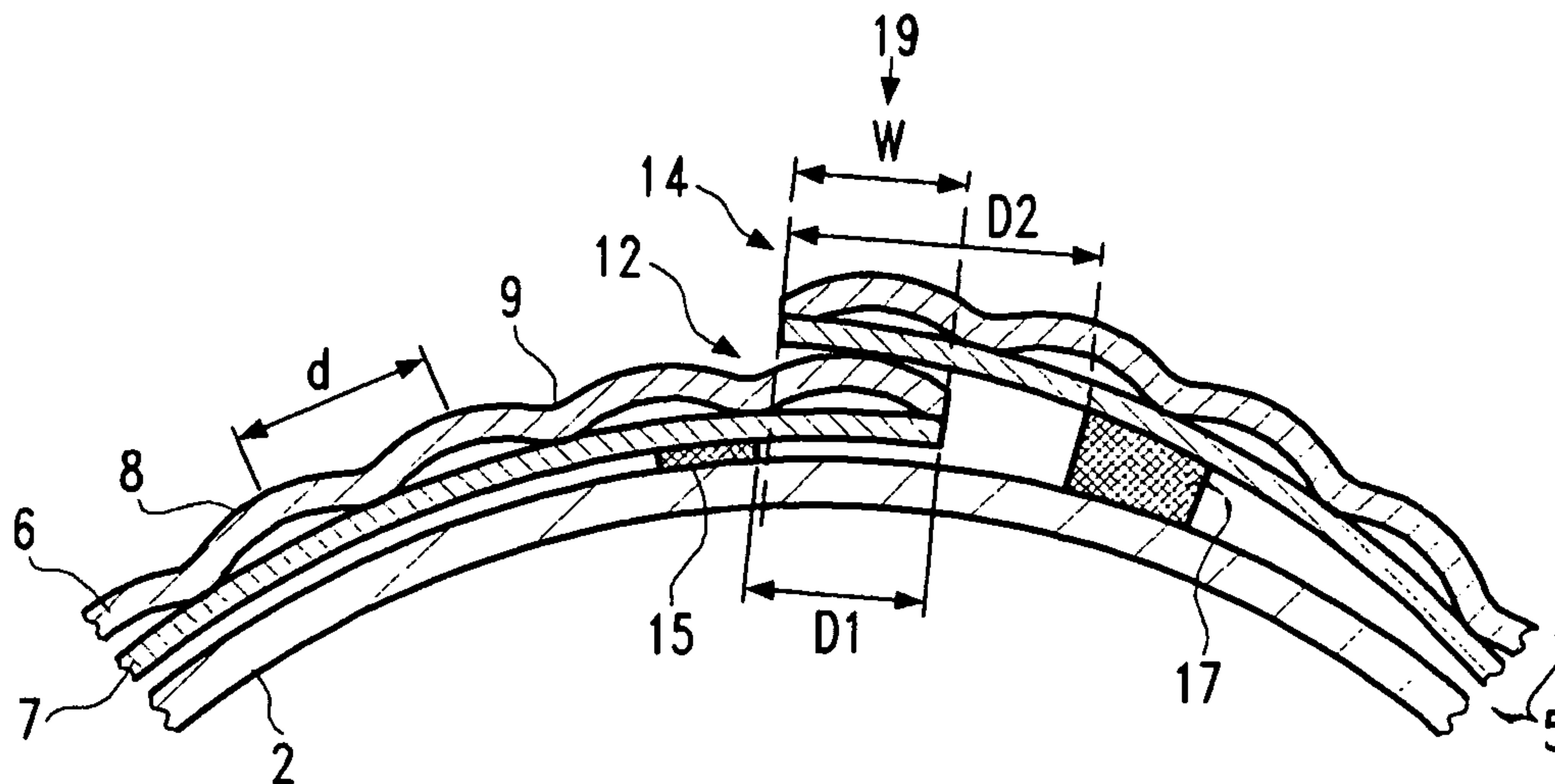

(57) Abstract: Cup (1) with an internal wall (2) and an external sleeve (5), the sleeve being formed from a blank (10) of corrugated material comprising a corrugated layer (6) and a Substrate layer (7) and being arranged such that the Substrate layer (7) faces towards the internal wall of the cup. A first end (12) of the blank (10) is overlapped at least partially by a second end (14) of the blank in an overlapping area (19). Further, the sleeve (5) is adhesively attached to the internal wall of the cup (1) at least by a first area (15) of adhesive being provided on an inner side of the sleeve on the first end of the blank and by a second area (17) of adhesive being provided on an inner side of the sleeve on the second end of the blank. The second area (17) of adhesive is provided at a distance from the overlapping edge (13) of the blank, thereby attaching each end of the blank (10) separately to the internal wall of the cup (1).

WO 2007/054318 A1

## INSULATED CUP

The present invention is related to a cup according to the preamble of claim 1.

Such a cup is known, for example, from DE 100 54 727 A1. The main purpose of these cups is to store cold or hot beverages. The corrugated material of the external sleeve provides for a thermal isolation of the cup. By means of this thermal isolation, the liquid in the cup may maintain its temperature for a longer time, and the consumer may more easily handle the cup, since the outer side of the cup neither becomes too hot, nor too cold.

The cup of DE 100 54 727 A1 is manufactured by providing adhesive on two opposing edges of the blank of corrugated material. After attaching the first edge of the blank to the internal wall of the cup, the blank is drawn around the internal wall, until the second edge overlaps the first edge and becomes adhesively attached to this first edge. Preferably, this conventional cup is manufactured in such a way that the flat substrate layer of the sleeve faces outwards, thereby facilitating printing on the sleeve.

Another container is known from US 5,772,111. This container, however, is rather different from the cup of DE 100 54 727 A1, since it is devoid of an internal wall. Instead, the container is formed by merely closing a blank of corrugated material into a conical shape and providing a container bottom. This container is formed in such a way that the corrugated layer faces outwards. However, compared to the cup of DE 100 54 727 A1, the container of US 5,772,111 is less stable and offers a lower degree of thermal isolation, due to the reduced number of layers.

The object of the present invention is to improve the known cup with respect to its stability, its aesthetic appearance and a facilitated way of manufacturing.

This object is solved by a cup with the features of claim 1. Advantageous embodiments of the invention are referred to by the dependent claims.

According to the invention, the second area of adhesive, i.e. the area of adhesive on the overlapping end of the blank for the sleeve, is provided at a distance from the second or

preferably overlapping edge of the blank. This is in clear contrast to the cup of DE 100 54 727 A1, according to which this second area of adhesive is provided exactly at the overlapping edge of the blank in order to directly attach this overlapping edge to the underlying edge of the blank and to thereby close the sleeve. The present invention, on the other hand, teaches to locate the second area of adhesive at a distance from the overlapping edge, thereby enabling to directly attach the overlapping edge of the blank to the internal wall of the cup. In other words, instead of closing the sleeve by an adhesive joint, the two ends of the blank are separately attached to the internal wall. This offers several advantages. Stability of the cup is enhanced by fixing each end of the blank separately to the internal wall. In the event that one adhesive joint becomes weak, the sleeve will still remain stably fixed to the internal wall of the cup. Further, the width of the overlap may be reduced significantly, since this overlapping area is not needed anymore for a mutual attachment of the two ends of the blank. By reducing the overlap, for example to a value of less than 1 mm or merely a few millimeters, material of the sleeve is saved, thereby also reducing manufacturing costs. In addition, the aesthetic appearance of the cup is improved, since the removal of adhesive from the overlap has to avoid unwanted leakage of adhesive from the overlap onto the exterior of the cup. Moreover, by being able to reduce the width of the overlap and by being able to avoid an additional layer of adhesive at the overlap, the thickness of the cup at the overlap can be reduced which, in turn, facilitates stacking of the cups without jamming. Thus, de-nesting of the cups is improved. This facilitates handling of the cups and reduces storage costs.

In a preferred embodiment, the distance of the second area of adhesive from the overlapping edge is at least as large as the width of the overlapping area. This ensures to keep the overlap free from adhesive, thereby restricting the wall thickness of the overlap and further avoiding the leakage of adhesive.

Depending on the cut of the blank of corrugated material, the overlap may have a constant width, but the width does not necessarily have to be constant. In particular, this width of the overlapping area may have a value between 0 and 4 mm, preferably between 0.5 and 2.5 mm. Depending on the size of the cup, this overlap may, of course, also be broader.

For the distance of the second area of adhesive from the overlapping edge, a value of 0.5 mm to 8 mm, and more particularly a value of 0.5 to 5 mm is preferred. In particular, this distance should be chosen large enough to ensure that no adhesive will leak through the overlapping area onto the exterior of the cup.

In an advantageous embodiment of the invention, the overlapping area is completely free of adhesive between the two overlapping ends of the blank. In such an embodiment, the risk of leakage of adhesive is further reduced.

It may also be contemplated to provide the other, first area of adhesive at a distance from the corresponding edge of the blank. When choosing this distance of the first area of adhesive from the overlapping edge appropriately, for example at least as large as the width of the overlapping area, the presence of adhesive between the internal wall of the cup and the sleeve may be avoided underneath the overlap. This will help to further reduce the resulting wall thickness at the overlap, thereby facilitating stacking.

According to an embodiment of the present invention, the corrugated layer of the sleeve material has wavepeaks spaced apart from the substrate layer, these wavepeaks extending in straight lines or in a wave-like pattern or in a zigzag pattern. The volume between the substrate layer and the wavepeaks has the major influence on the thermal isolation of the cup. If desired, this volume may also be filled with a certain material, for example by foam, in order to further enhance the thermal isolation properties.

By having adjacent wavepeaks of the corrugated material arranged at a constant distance, manufacturing costs of the cup may further be reduced since the blank for the sleeve may be cut from any portion of the corrugated material without worrying about the exact location of the cut.

The width of the overlapping area of the sleeve is preferably chosen to be less than three times the average distance between adjacent wavepeaks of the corrugated material, even more preferred less than twice the average distance between adjacent wavepeaks. Such a comparatively short overlap helps to save material, thereby reducing manufacturing costs, and to avoid the outer, overlapping edge from detaching from the cup.

The first area of adhesive and/or the second area of adhesive advantageously comprises at least one strip of adhesive, in order to form a strong bond between the corresponding end of the blank and the internal wall of the cup.

The strip of adhesive may, for example, be arranged parallel to the corresponding edge of the blank. This can ensure that no portion of the edge may detach further from the internal wall than other portions, if at all.

In addition or alternatively to a strip of adhesive, the first area of adhesive and/or the second area of adhesive may comprise at least one spot or dot of adhesive. Without significantly affecting stability of the cup, this may reduce the amount of adhesive used, thereby further decreasing manufacturing costs and helping to prevent leakage of adhesive through the overlap.

In a preferred embodiment, several of such spots of adhesive are arranged on a line parallel to the corresponding edge of the blank, having similar effects with respect to stability of the cup as a strip of adhesive, but with a reduced amount of adhesive.

In addition to the first and second areas of adhesive, at least one additional area of adhesive may also be provided between the first and second areas elsewhere on the sleeve. By attaching the sleeve to the internal wall at a third or further position, stability of the cup and sleeve assembly may further be enhanced.

Advantageous materials for the sleeve are plastic or cardboard material. Of course, other suitable materials may also be used.

A significant advantage may be achieved by providing the internal wall of the cup with de-nesting means. Such de-nesting means prevent jamming of the cups when stacking several identical cups into one another. This allows to more easily separate the stacked cups.

For example, the de-nesting means may be shaped as at least one projection which projects from the internal wall into the interior of the cup. When being stacked, the upper

cup may rest with its bottom wall on the de-nesting projection of the lower cup, which prevents the cups from being stacked too tightly.

Such a de-nesting projection may, in turn, comprise a circumferential projection and/or at least one sectional projection, for example a step or a dimple. When providing such a projection only on the interior wall of the cup, the outer appearance of the cup is not negatively influenced.

Some embodiments of the present invention will now be described in more detail with reference to the attached drawings. In particular,

FIG. 1 shows a perspective view of a preferred embodiment of a cup according to the present invention,

FIG. 2 shows the blank of the sleeve used for the cup in FIG. 1,

FIG. 3 shows a horizontal section of the overlapping area of the cup shown in FIG. 1,

FIG. 4 shows a perspective view of a second embodiment,

FIG. 5 shows a front view of a third embodiment, and

FIG. 6 shows a perspective view of a fourth embodiment of a cup according to the present invention.

Corresponding features are referred to by the same reference numerals throughout the drawings.

Figure 1 shows a preferred embodiment of a cup 1 according to the present invention. The cup comprises an internal wall 2, which has a frusto-conical shape, the lower end being closed by a cup bottom 3. The opposite, upper end of the cup is provided with a broad rim 4, which may for example be formed as a rolled upper end of the internal wall 2.

On the outside, the cup 1 is provided with an external sleeve 5, which extends over the complete height of the internal wall 2, i.e. from the cup bottom 3 to the upper rim 4. This

sleeve 5 is formed from a blank of corrugated material, in particular cardboard material, comprising a corrugated layer 6 and a substrate layer 7, c.f. Figure 3. As shown in Figures 1 and 3, the sleeve 5 is arranged in such a way that the substrate layer 7 faces towards the internal wall 2 of the cup 1, while the corrugated layer 6 faces towards the outside of the cup 1. This corrugated layer 6 comprises wavepeaks 8, at which the corrugated layer 6 is spaced apart from the substrate layer 7. Each wavepeak 8 extends in a wave-like pattern at a slightly inclined angle from the cup bottom 3 to the rim 4. Each pair of adjacent wavepeaks 8 is arranged at a constant distance  $d$  from each other. Between the wavepeaks 8, there is a trough 9, at which the corrugated layer 6 and the substrate layer 7 are attached to each other.

The sleeve 5 of the cup 1 is formed from an initially flat blank 10 of corrugated material, as shown in Figure 2. This blank 10 is shaped in such a way that, when being closed, it forms a frustro-conical sleeve 5, the conicity of which corresponds to the conicity of the internal wall 2. In this shape, the blank 10 may be cut from a larger area of corrugated material.

As shown in Figure 2, the blank 10 of corrugated material may be formed as a slightly curved strip of material, having a first edge 11 at a first end 12 of the strip and a second edge 13 at an opposite, second end 14 of the strip. Parallel to the first edge 11, but spaced apart by a distance  $D1$  from the first edge 11, a first area 15 of adhesive is provided on the internal side of the blank 10, i.e. on the substrate layer 7. This first area 15 of adhesive is shown hatched in Figure 2. On the first area 15 of adhesive, adhesive is provided in the form of several spots or dots 16, which are spaced at regular intervals on the first area 15 of adhesive. In particular, these spots 16 of adhesive are arranged on a line which extends substantially parallel to the first edge 11 of the blank 10.

In corresponding relationship to the opposite, second edge 13 of the blank 10, but spaced apart from this second edge 13 by a distance  $D2$ , a second area 17 of adhesive is provided on the blank 10. Similar to the first area 15, this second area 17 of adhesive also comprises a number of discrete spots 16 of adhesive, which are arranged on a line extending substantially parallel to the second edge 13 of the blank 10. Instead of providing a number of discrete spots 16 of adhesive, or in addition to these spots 16, the adhesive may also be provided in the form of a strip on the respective area 15, 17 of adhe-



sive, or in other suitable arrangements. In addition, adhesive may optionally also be provided on additional areas 18 of adhesive between the first area 15 and the second area 17. Preferably, the adhesive on the first and second areas 15, 17 is hot melt glue, which allows a fast assembly, while the adhesive on the additional area(s) 18 is cold glue, which achieves a stronger adhesion. If speed of the assembly is not an issue, cold glue may also be used as the adhesive on the first and/or second areas.

In order to manufacture the cup 1, the blank 10 for the sleeve is initially formed separately from the rest of the "bare" cup 1. In particular, the blank 10 can be cut from a larger sheet of corrugated material. After providing adhesive on the blank 10 on the first area 15, the second area 17 and – optionally – also on the additional area(s) 18, the blank 10 is formed around the "bare" cup 1. In order to do so, the first end 12 of the blank 10 is pressed against the cup 1 and attached to the exterior of the internal wall 2 by means of the adhesive 16 on the first area 15 of adhesive. Consecutively, the blank 10 is wrapped or drawn around the internal wall 2 and attached to the internal wall 2 by the adhesive on the areas 18 and, eventually, by the adhesive 16 on the second area 17 of adhesive. As an alternative to providing adhesive on all areas on the blank 10 simultaneously, the adhesive may also be applied sequentially during the formulation of the blank 10 around the internal wall 2. In another alternative method, the blank first contacts the bare cup with its center, before the two ends 12, 14 of the blank are wrapped around the cup symmetrically and each end attached separately to the internal wall 2. A clamp can be used for pressing the two ends 12, 14 together and onto the cup 1.

Eventually, when the blank 10 is formed all around the internal wall 2, in order to form a sleeve 5 covering the internal wall 2, the second end 14 of the blank 10 overlaps the first end 12. In particular, the overlap 19 has a width  $W$ , as shown in Figures 2 and 3. Although this width  $W$  is preferably not larger than the distance  $d$  between two adjacent wavepeaks 8, it may also be broader, depending on the value of the distance  $d$ .

Although the distance  $D1$  spacing apart the first edge 11 from the first area 15 of adhesive may be zero, it is preferably non-zero, especially when in the absence of an overlap or  $W = 0$ , even more preferred at least as large as the width  $W$  of the overlap. While still being close enough to the first edge 11 of the blank 10 in order to avoid a detachment of the blank 10 from the internal wall 2, the relation of  $D1$  being at least as large as  $W$  al-

lows the overlapping area to be free of adhesive between the first end 12 of the blank 10 and the internal wall 2. Thus, the wall thickness at the overlap can be reduced, while still offering sufficient stability of the assembly.

As also shown in Figures 2 and 3, the distance D2 between the second edge 13 and the second area 17 of adhesive is at least as large as the width W of the overlap, preferably only slightly larger than the width W if W is non-zero. The result of this arrangement can be seen in Figure 3: after the attachment between the second end 14 of the blank 10 to the internal wall 2 at the second area 17 of adhesive, the second end 14 of the sleeve 5 opens outwards, in order to be able to overlap the first end 12 of the blank 10. The overlapping area 19 is shown hatched in Figure 2. It has a width W between 0 and 4 mm, preferably between 0.5 and 2.5 mm. Such a small width W with the above described advantages of saving material and improving the aesthetic appearance of the cup 1 is made possible by the present invention by arranging the second area 17 of adhesive at a non-zero distance D2 from the overlapping edge 13 of the blank 10. Instead of attaching the two ends 12, 14 of the blank 10 to each other and then to the internal wall 2, as it is done in the prior art, the present invention teaches to attach each end 12, 14 of the blank 10 separately to the internal wall 2. While this provides excellent stability of the assembly, the overlapping area 19 can be made devoid of adhesive between the first end 12 and the second end 14 of the blank 10. In turn, the width W of the overlapping area 19 may be reduced to such a small value. Nevertheless, by fixing both ends 12, 14 of the blank 10 separately to the internal wall 2 a detachment of each end 12, 14 is achieved even more securely than in the prior art.

As an additional feature, which is also shown in Figure 1, the cup 1 of the present invention may be provided with de-nesting means 20. In the embodiment shown in Figure 1 the de-nesting means 20 are formed as a step or projection which projects from the internal wall 2 into the interior of the cup 1. Depending on the conicity of the cup 1, the projection 20 is arranged at such a height from the bottom 3 that – when stacking the cups 1 – an upper cup 1 may rest on the de-nesting projection 20 of a lower cup 1 with its bottom 3 before being stacked into the lower cup 1 too tightly. The de-nesting projection 20 may be formed as a circumferential projection extending all around the circumference of the cup 1, or as one or several spaced apart sectional projections on the same height over the bottom 3 of the cup 1.

Figure 4 shows a perspective view of a second embodiment of a cup according to the present invention. In contrast to the first embodiment, the distance  $d$  between adjacent wavepeaks 8 is smaller.

A third embodiment of the present invention is shown in Figure 5. The sleeve 5 of the cup 1 shown in Figure 5 has a reduced height, i.e. its height is smaller than the distance between the cup bottom 3 and the rim 4.

Another embodiment of a cup 1 is shown in Figure 6. This embodiment differs from the preceding embodiments in that the wavepeaks 8 on the corrugated material of the sleeve 5 extend in straight lines instead of extending in a wave-like pattern. Of course, the sleeve 5 of this embodiment may also be made smaller, i.e. extending over less than the complete height of the cup 1.

Starting from the embodiment shown in the attached drawings and described with respect thereto, the cup 1 of the present invention may be varied in several ways. For example, the wavepeaks of the corrugated material may extend in straight lines, in a zig-zag pattern or with varying distances between adjacent wavepeaks 8. The space between the substrate layer and the corrugated layer 6 does not have to be empty but can be filled with a suitable material for enhancing thermal isolation properties, such as foam. Further, the internal wall 2 of the cup 1 does not have to be formed from one single layer only, but it may be formed in a double wall shape. A less expensive version of the cup 1 may be formed without the de-nesting means 20, and without additional areas 18 of adhesive. Further variations are also possible.

## CLAIMS

1. Cup (1) with an internal wall (2) and an external sleeve (5), the sleeve (5) being formed from a blank (10) of corrugated material comprising a corrugated layer (6) and a substrate layer (7) and being arranged such that the substrate layer (7) faces towards the internal wall (2) of the cup (1), wherein a first end (12) of the blank (10) is in particular overlapped at least partially by a second end (14) of the blank (10) in an overlapping area (19), and wherein the sleeve (5) is adhesively attached to the internal wall (2) at least by a first area (15) of adhesive being provided on an inner side of the sleeve (5) on the first end (12) of the blank (10) and by a second area (17) of adhesive being provided on an inner side of the sleeve (5) on the second end (14) of the blank (10),  
**characterized by**  
the second area (17) of adhesive being provided at a distance (D2) from an edge (13) at the second end (14) of the blank (10).
2. Cup according to claim 1, **characterized in that** the distance (D2) of the second area (17) of adhesive from the overlapping edge (13) is at least as large as the width (W) of the overlapping area (19).
3. Cup according to any of claims 1 or 2, **characterized in that** the width (W) of the overlapping area (19) is between 0 and 4 mm.
4. Cup according to any of the preceding claims, **characterized in that** the width (W) of the overlapping area (19) is between 0.5 and 2.5 mm.
5. Cup according to any of the preceding claims, **characterized in that** the distance (D2) of the second area (17) of adhesive from the overlapping edge (13) is between 0.5 mm and 8 mm, preferably between 0.5 mm and 5 mm.
6. Cup according to any of the preceding claims, **characterized by** the overlapping area (19) being free of adhesive between the two overlapping ends (12, 14) of the blank (10).

7. Cup according to any of the preceding claims, **characterized by** the first area (15) of adhesive being provided at a distance (D1) from the corresponding edge (11) of the blank (10).
8. Cup according to claim 7, **characterized in that** the distance (D1) of the first area (15) of adhesive from the overlapped edge (11) is at least as large as the width (W) of the overlapping area (19).
9. Cup according to any of the preceding claims, **characterized in that** the corrugated layer (6) has wavepeaks (8) spaced apart from the substrate layer (7), these wavepeaks (8) extending in straight lines or in a wavelike pattern or in a zigzag pattern.
10. Cup according to claim 9, **characterized in that** the distance (d) between adjacent wavepeaks (8) is constant.
11. Cup according to claim 9 or 10, **characterized in that** the width (W) of the overlapping area (19) is less than three times the average distance (d) between adjacent wavepeaks (8), preferably less than twice the average distance (d) between adjacent wavepeaks (8).
12. Cup according to any of the preceding claims, **characterized in that** the first area (15) of adhesive and/or the second area (17) of adhesive comprises at least one strip of adhesive.
13. Cup according to claim 12, **characterized in that** the strip is arranged parallel to the corresponding edge (11, 13) of the blank (10).
14. Cup according to any of the preceding claims, **characterized in that** the first area (15) of adhesive and/or the second area (17) of adhesive comprises at least one spot (16) of adhesive.

15. Cup according to claim 14, **characterized in that** several spots (16) of adhesive are arranged on a line parallel to the corresponding edge (11, 13) of the blank (10).
16. Cup according to any of the preceding claims, **characterized in that** at least one additional area (18) of adhesive is provided between the first (15) and the second (17) areas of adhesive.
17. Cup according to any of the preceding claims, **characterized in that** a hot melt glue is provided on the first area (15) of adhesive and/or on the second area (17) of adhesive.
18. Cup according to one of claims 16 or 17, **characterized in that** cold glue is provided on at least one additional area (18) of adhesive.
19. Cup according to any of the preceding claims, **characterized in that** the sleeve (5) is made from plastic or cardboard material.
20. Cup according to any of the preceding claims, **characterized in that** the internal wall (2) of the cup (1) is provided with de-nesting means (20).
21. Cup according to claim 20, **characterized in that** the de-nesting means (20) are shaped as at least one projection projecting into the interior of the cup (1).
22. Cup according to claim 21, **characterized in that** the projection (20) comprises a circumferential projection and/or at least one sectional projection.

1/6

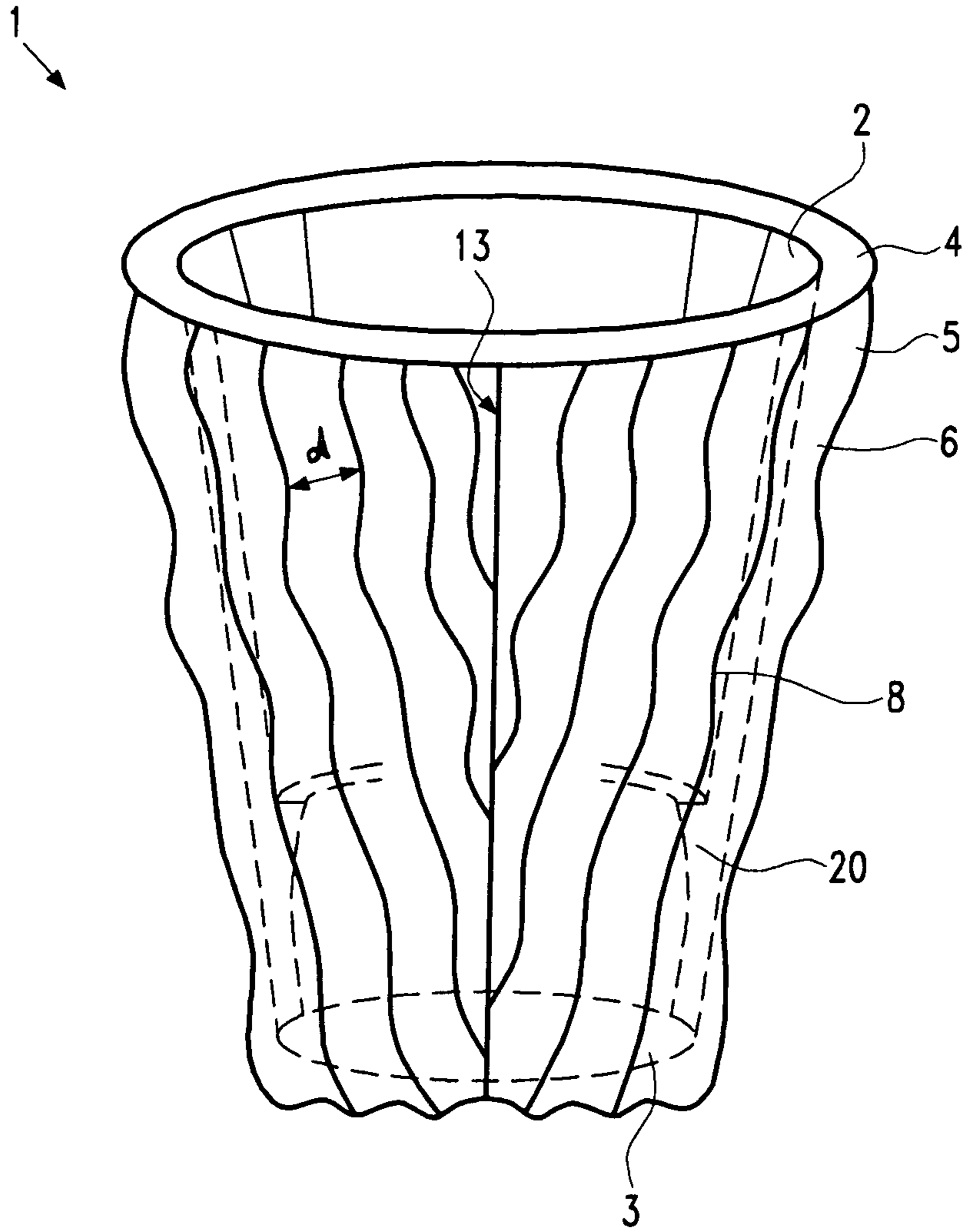

FIG. 1

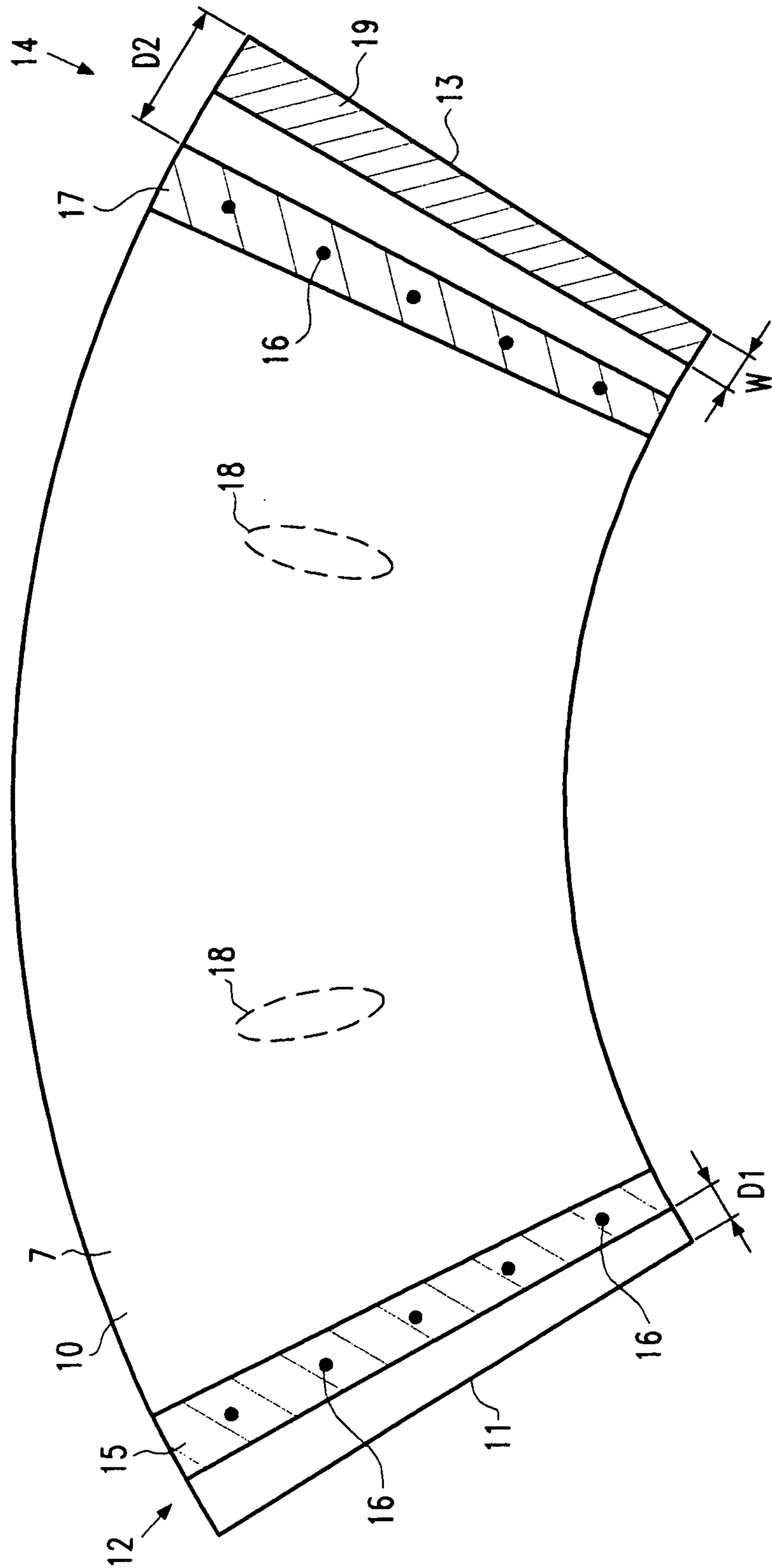

FIG. 2



3/6

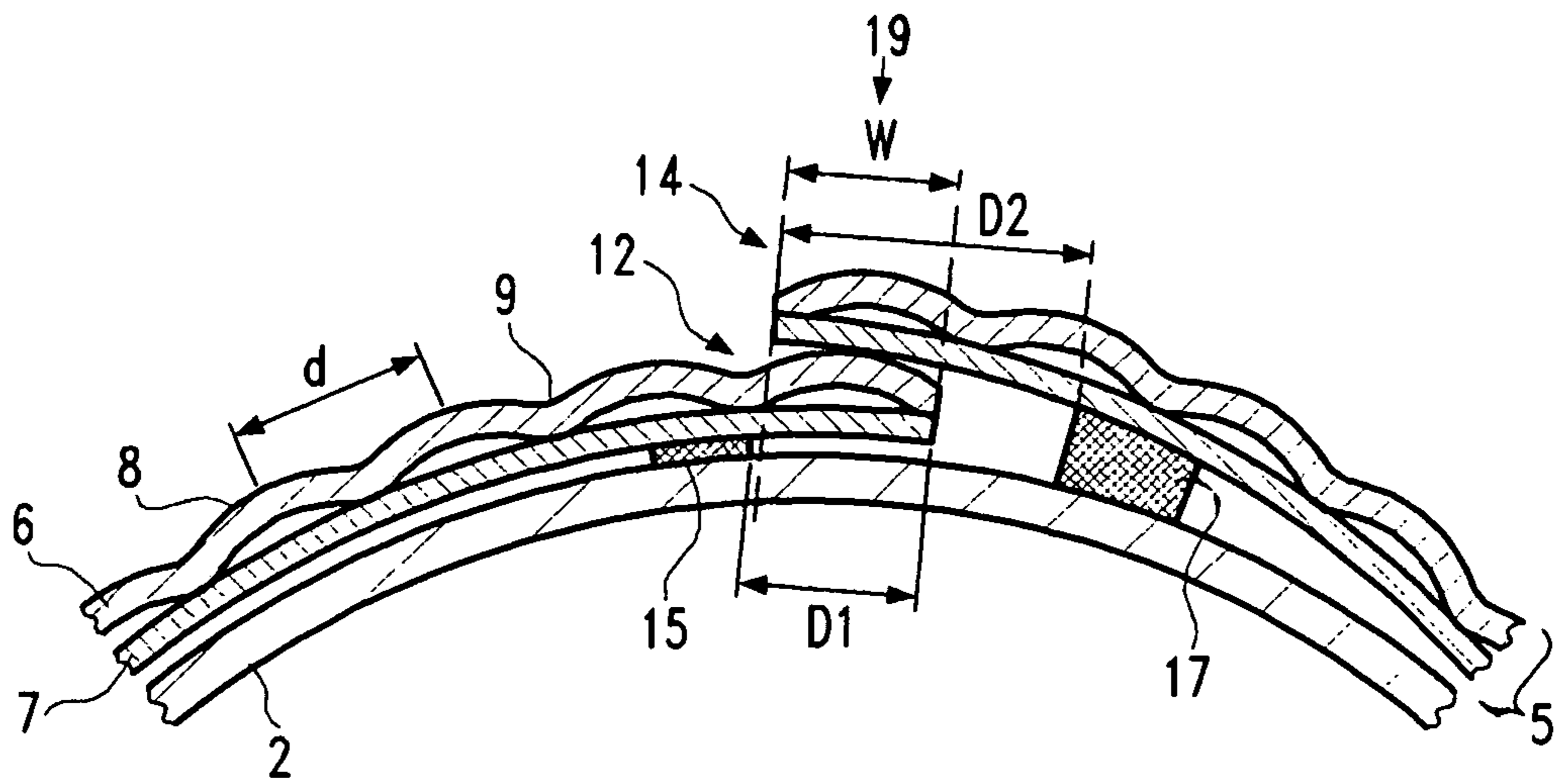

FIG. 3

4/6

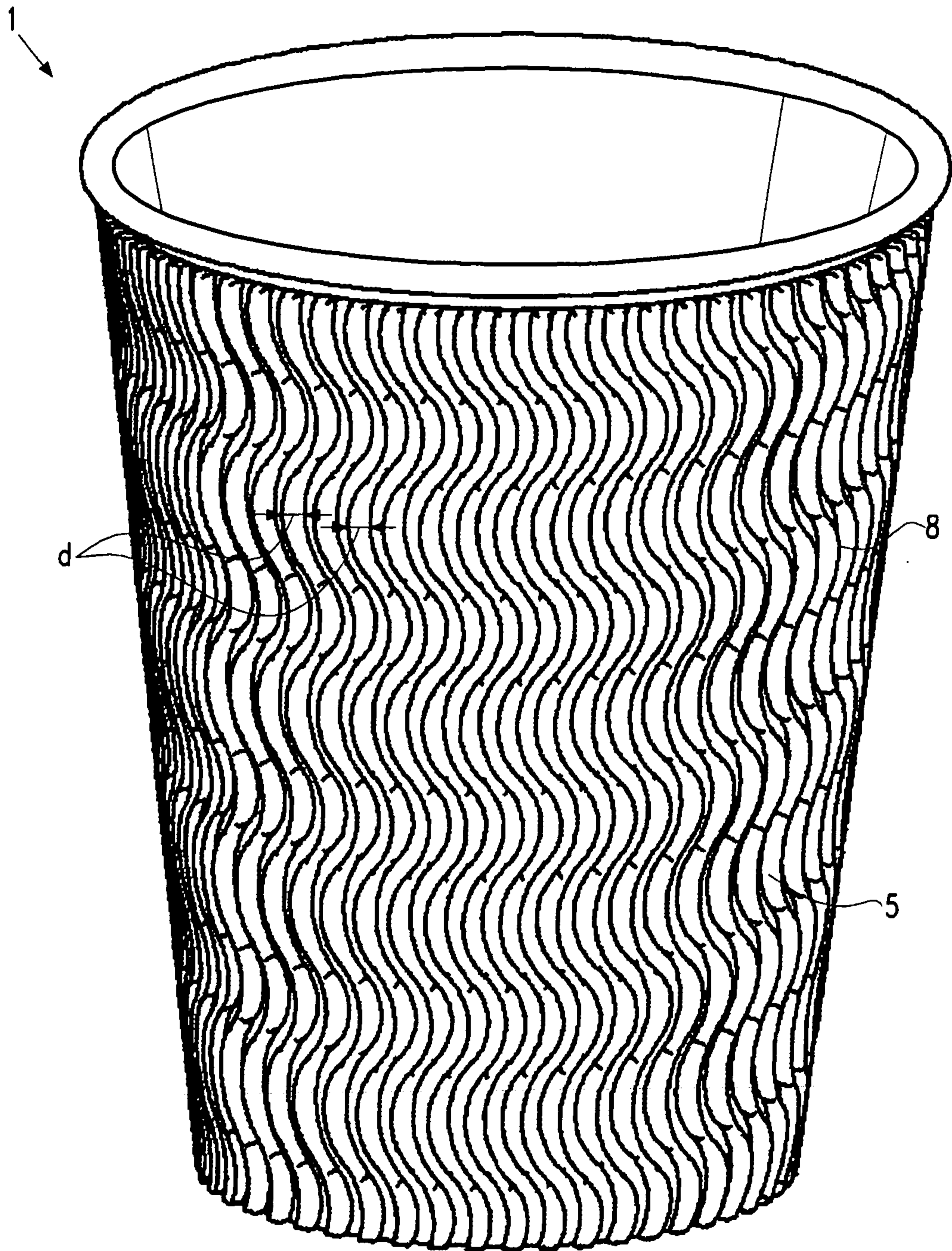

FIG. 4

5/6

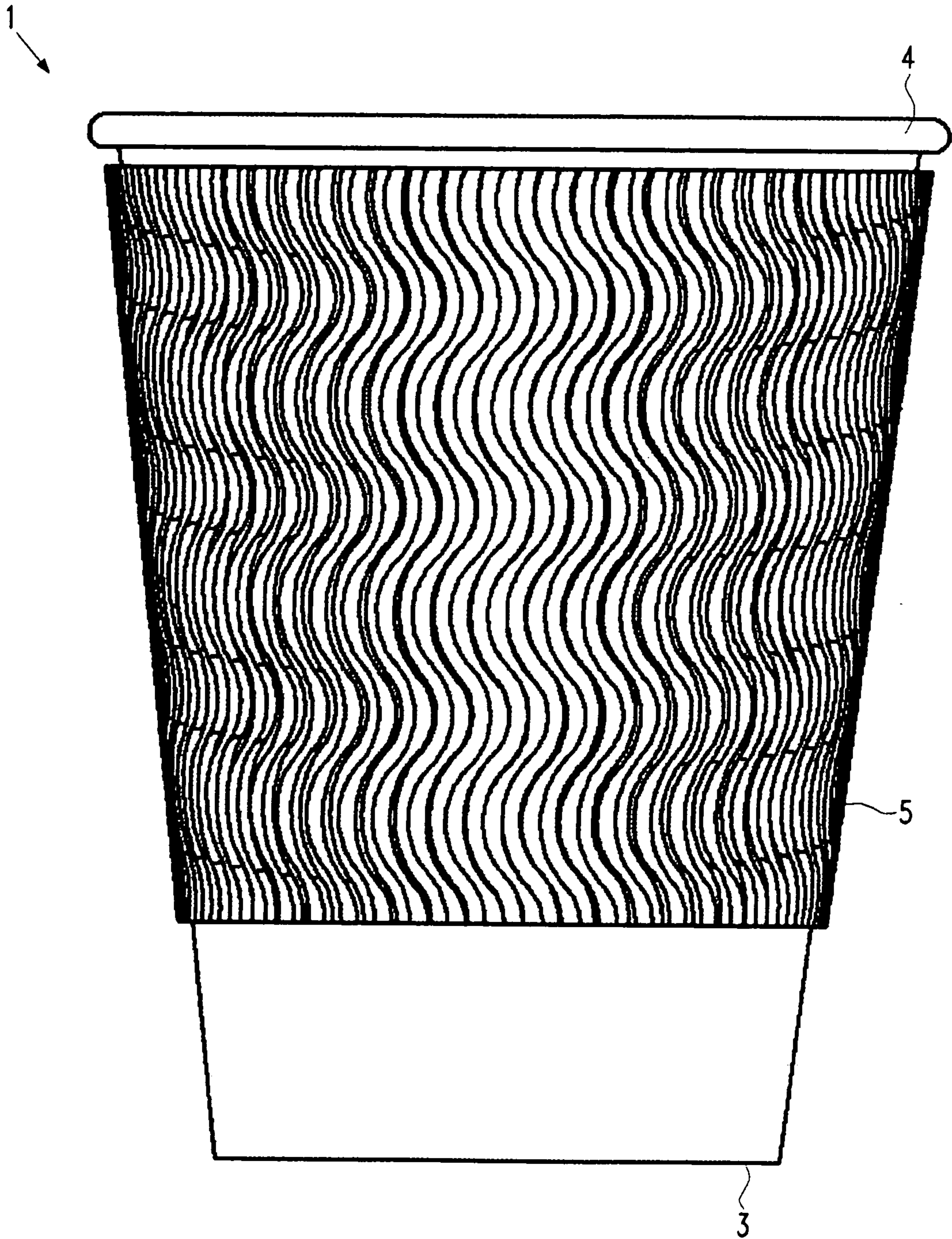

FIG. 5

6/6

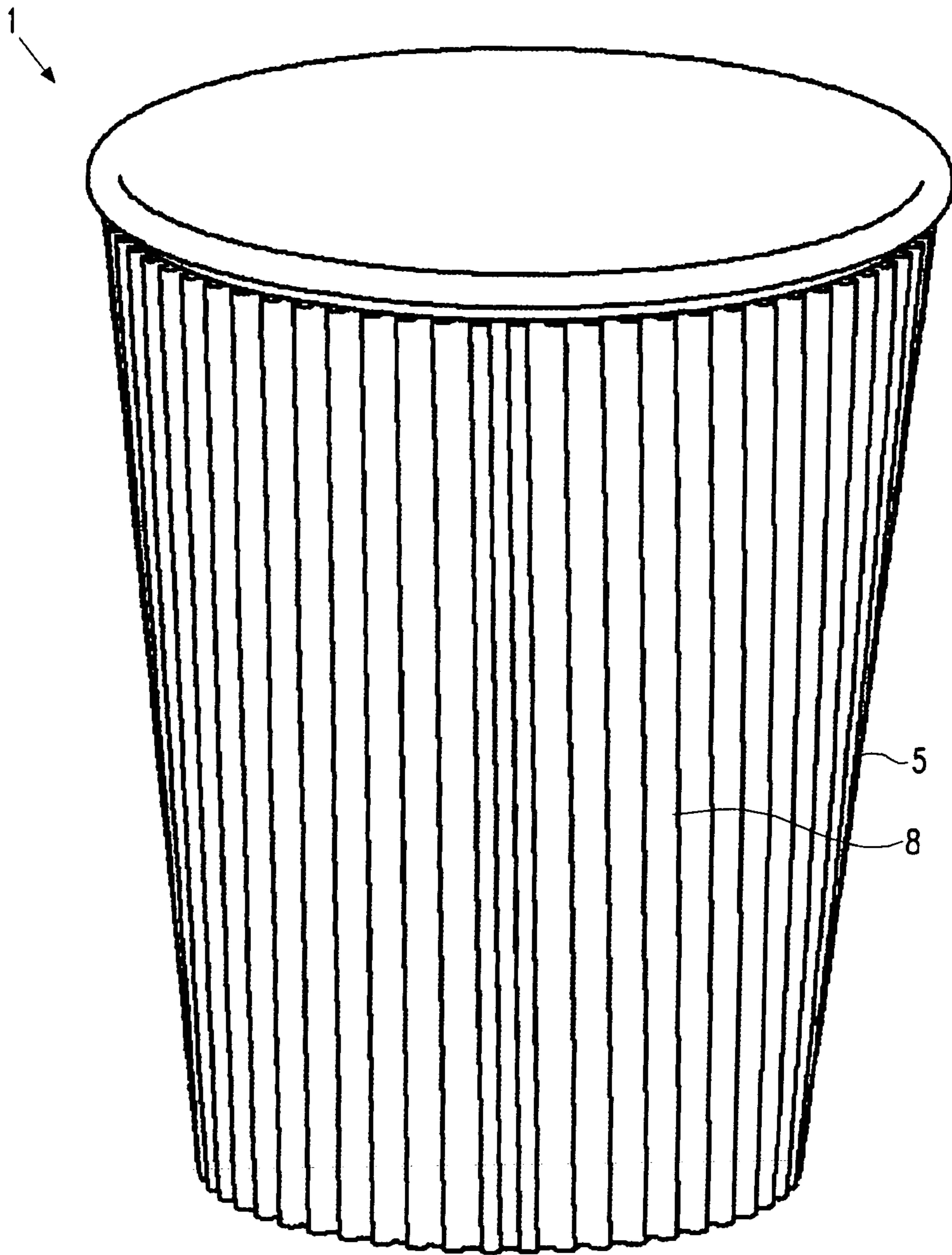

FIG. 6

