



INTERNATIONAL APPLICATION PUBLISHED UNDER THE PATENT COOPERATION TREATY (PCT)

| | | |
|---|------------------|---|
| <p>(51) International Patent Classification ⁵ : F16D 13/71, 13/56, 13/68</p> | <p>A1</p> | <p>(11) International Publication Number: WO 94/04838 (43) International Publication Date: 3 March 1994 (03.03.94)</p> |
| <p>(21) International Application Number: PCT/US93/07513 (22) International Filing Date: 10 August 1993 (10.08.93) (30) Priority data: 929,299 13 August 1992 (13.08.92) US (71) Applicant: TILTON ENGINEERING, INC. [US/US]; 25 Easy Street, Buellton, CA 93427 (US). (72) Inventors: HENDRIX, Roger, Hubert ; 3354 Drake Drive, Santa Maria, CA 93455 (US). BERNAL, Christopher, Patrick ; 365 St. Joseph Street, Los Alamos, CA 93440 (US). TILTON, McLane ; 2645 Quail Valley Road, Solvang, CA 93463 (US).</p> | | <p>(74) Agents: GANS, Bernard, R. et al. ; Poms, Smith, Lande & Rose, 2121 Avenue of the Stars, Suite 1400, Los Angeles, CA 90067 (US). (81) Designated States: CA, JP, European patent (AT, BE, CH, DE, DK, ES, FR, GB, GR, IE, IT, LU, MC, NL, PT, SE). Published <i>With international search report.</i></p> |

(54) Title: CARBON TO CARBON FRICTION MECHANISM

(57) Abstract

A carbon to carbon friction mechanism (10) which includes a lightweight pressure plate (58) directly mounted to an adjacent carbon plate (52) so that the pressure plate (58) is kept concentrically aligned during operation of the mechanism. The directly mounted pressure plate (58) and adjacent carbon plate (52) may be used as components of a carbon to carbon friction clutch. Sufficient clearances are provided between the pressure plate (58) and its adjacent carbon plate (52) to allow for thermal expansion of the materials used for the pressure and carbon plates.

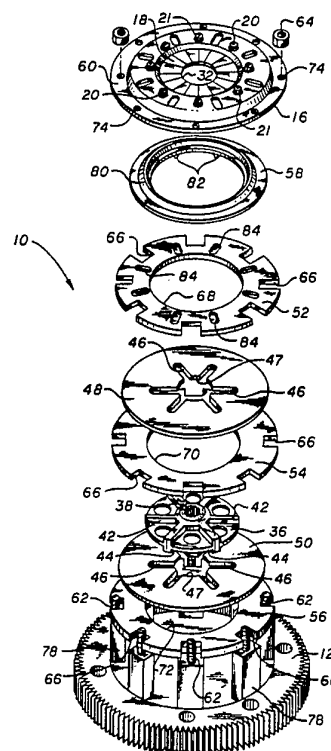

FOR THE PURPOSES OF INFORMATION ONLY

Codes used to identify States party to the PCT on the front pages of pamphlets publishing international applications under the PCT.

| | | | | | |
|----|--------------------------|----|--|----|--------------------------|
| AT | Austria | FR | France | MR | Mauritania |
| AU | Australia | GA | Gabon | MW | Malawi |
| BB | Barbados | GB | United Kingdom | NE | Niger |
| BE | Belgium | GN | Guinea | NL | Netherlands |
| BF | Burkina Faso | GR | Greece | NO | Norway |
| BG | Bulgaria | HU | Hungary | NZ | New Zealand |
| BJ | Benin | IE | Ireland | PL | Poland |
| BR | Brazil | IT | Italy | PT | Portugal |
| BY | Belarus | JP | Japan | RO | Romania |
| CA | Canada | KP | Democratic People's Republic of Korea | RU | Russian Federation |
| CF | Central African Republic | KR | Republic of Korea | SD | Sudan |
| CG | Congo | KZ | Kazakhstan | SE | Sweden |
| CH | Switzerland | LI | Liechtenstein | SI | Slovenia |
| CI | Côte d'Ivoire | LK | Sri Lanka | SK | Slovak Republic |
| CM | Cameroon | LU | Luxembourg | SN | Senegal |
| CN | China | LV | Latvia | TD | Chad |
| CS | Czechoslovakia | MC | Monaco | TG | Togo |
| CZ | Czech Republic | MG | Madagascar | UA | Ukraine |
| DE | Germany | ML | Mali | US | United States of America |
| DK | Denmark | MN | Mongolia | UZ | Uzbekistan |
| ES | Spain | | | VN | Viet Nam |
| FI | Finland | | | | |

CARBON TO CARBON FRICTION MECHANISM

CROSS-REFERENCE TO RELATED APPLICATION

5 The subject matter of this application is related to the subject matter of copending application, filed with the present application, entitled "HUB RETAINING APPARATUS," assigned to Tilton Engineering, Inc., the assignee of the present application.

10 BACKGROUND OF THE INVENTION

The present invention relates generally to friction operating mechanisms, and more particularly to carbon to carbon friction mechanisms.

15 In the past, carbon discs or plates have been used to produce lightweight friction operating mechanisms such as clutches. one such carbon to carbon friction clutch is disclosed in U.S. Patent No. 4,846,326, issued to Tilton et al. on July 11, 1989. In this clutch assembly, carbon plates are used for both the driver and driven plates.
20 Bolts and spacing blocks passing through peripheral apertures in the carbon driver plates and in a pressure plate are used to bolt the clutch assembly to a flywheel. As such, the outer diameter of the pressure plate is sized to accommodate the peripheral apertures needed for the bolts
25 and spacing blocks. This results in increased weight for the clutch assembly.

SUMMARY OF THE INVENTION

30 It is an object of this invention to provide a carbon to carbon friction mechanism that is lightweight, permitting easier braking, less sluggish gear shifting, and greater rates of acceleration and deceleration.

It is another object of this invention to provide a carbon to carbon friction mechanism that may be used for a
35 clutch or for other mechanisms.

It is still another object of this invention to provide a carbon to carbon friction mechanism that allows operation of the mechanism at high temperatures.

5 It is still another object of this invention to provide a carbon to carbon friction mechanism that is economical to manufacture.

10 These and other objects and advantages are attained by a carbon to carbon friction mechanism that includes a lightweight pressure plate directly mounted to an adjacent carbon plate so that the pressure plate is kept concentrically aligned during operation of the mechanism. The directly mounted pressure plate and adjacent carbon plate may be used as components of a carbon to carbon friction clutch. Sufficient clearances are provided between 15 the pressure plate and its adjacent carbon plate to allow for thermal expansion of the materials used for the pressure and carbon plates.

The various features of the present invention will be best understood together with further objects and advantages 20 by reference to the following description of the preferred embodiments taken in conjunction with the accompanying drawings.

BRIEF DESCRIPTION OF THE DRAWINGS

25 FIG. 1 is an exploded isometric view of the carbon to carbon friction mechanism of the present invention shown used in a friction clutch;

FIG. 2 is an exploded isometric view of a pressure plate with downwardly extending lugs and of a carbon plate with radial slots that are used with the friction mechanism 30 of FIG. 1;

FIG. 3 is a cross-sectional view taken in the direction of arrows 3-3 of FIG. 2 after the pressure plate is mounted on the carbon plate;

35 FIG. 4 is an exploded isometric view of another embodiment of the pressure plate with a shaped outer

periphery, and of another embodiment of the carbon plate having a corresponding recess that matches the shaped periphery;

5 FIG. 5 is an enlarged, partial cross-sectional view of the clutch and flywheel of FIG. 1, showing the clutch assembled to an output shaft and interacting with a throwout bushing;

10 FIG. 6 is a cross-sectional view of another embodiment of a pressure plate with an annular peripheral portion, and of another embodiment of a carbon plate having a corresponding peripheral groove, showing the pressure plate mounted on the carbon plate; and

15 FIG. 7 is a cross-sectional view of an annular fulcrum, and of another embodiment of a carbon plate having an upwardly extending annular portion with an annular groove therein, showing the annular fulcrum mounted in the annular groove.

DESCRIPTION OF THE PREFERRED EMBODIMENTS

20 The following specification taken in conjunction with the drawings sets forth the preferred embodiments of the present invention in such a manner that any person skilled in the art can make and use the invention. The embodiments of the invention disclosed herein are the best modes
25 contemplated by the inventors for carrying out their invention in a commercial environment, although it should be understood that various modifications can be accomplished within the parameters of the present invention.

30 FIG. 1 shows an exploded view of a carbon to carbon friction mechanism 10 of the present invention used in a friction clutch. The clutch may be assembled to a flywheel 12. The flywheel 12, for example, may be rotated by an engine crankshaft (not shown). The clutch uses friction to transmit torque from the engine crankshaft to an output
35 shaft 14 (see FIG. 5), and then, for example, to a gearbox (not shown).

It is important to note that the carbon to carbon friction mechanism 10 may also be used with brakes or any other mechanisms. FIG. 1 illustrates only one practical application of the friction mechanism 10.

5 The clutch of FIG. 1 is an improvement to the carbon to carbon friction clutch described in U.S. Patent No. 4,846,326, issued to Tilton et al. on June 11, 1989, the disclosure of which is hereby incorporated by reference thereto. The parts of the clutch are shown in Figs. 1 and
10 5. A clutch cover 16 is bolted to a diaphragm spring 18 by a plurality of bolts 20 and nuts 21. Any number of bolts 20 may be used. Also, any type of spring may be used instead of diaphragm spring 18, and any other desirable type of fastener may be used instead of bolts 20 for the purpose
15 of attaching the spring 18 to the cover 16. Pivots 22 and 24 attached to the cover 16 and washers 26, respectively, allow an outer periphery 28 of the spring 18 to move upward as indicated by arrow 30 in FIG. 5, when an inner periphery 32 of the spring 18 is forced downward as indicated by arrow
20 34.

A coupling hub 36 having a splined central aperture 38 is engaged to splines 38 of the output shaft 14, so that the shaft 14 will rotate with the hub 36. As shown in FIG. 5, a throwout bushing 40 is free to move longitudinally along
25 shaft 14 for the purpose of forcing inner periphery 32 of spring 18 downward and outer periphery 28 upward in order to disengage the clutch, as discussed below. Bushing 40 is moved downward, for example, by a foot pedal in an automobile, or by any desirable means.

30 As shown in FIG. 1, the coupling hub 36 has top and bottom radial fingers 42 and 44, respectively. The fingers 42 and 44 engage radial slots 46 extending from apertures 47 in driven carbon plates 48 and 50 positioned at the top and bottom sides of the hub 36. As such, the driven carbon
35 plates 48 and 50 rotate with the coupling hub 36. The hub 36 is preferably made out of a lightweight metal such as

aluminum. However, any desirable metal may be used. Sufficient clearances are provided between the metal fingers 42 and 44 and the radial slots 46 of the carbon plates 48 and 50 to allow for the difference in thermal expansion
5 between carbon and metal during high operating temperatures.

It is important to note that any number of fingers 42 and 44 and slots 46 may be used. Also, the shape or configuration of the fingers and slots may be varied as desired.

10 As best shown in FIG. 5, driver carbon plates 52, 54 and 56 are disposed, respectively, above, between and below the driven carbon plates 48 and 50, when the clutch is assembled to the flywheel 12. Plates 52, 54 and 56 have inner diameters 68, 70 and 72, respectively, which are
15 preferably equal. However, the diameters 68, 70 and 72 may vary if desired. As discussed below, a pressure plate 58 is directly mounted on top of driver carbon plate 52. The pressure plate 58 is preferably made from metal. However, any desirable material may be used for the plate 58 such as
20 carbon.

The clutch cover 16 has peripheral apertures 74 in an annular outer portion 60 thereof. Likewise, the carbon driver plates 52, 54 and 56 have peripheral apertures 66 therein as shown in FIG. 2, and the flywheel 12 has
25 corresponding peripheral apertures 76 therein (see FIG. 5).

Assembly of the clutch is achieved by stacking the components on top of the flywheel 12, and passing spacing blocks 78 through apertures 76 in the flywheel 12, and through apertures 66 in the driver carbon plates 52, 54 and
30 56. Bolts 62 and nuts 64 are then used to bolt the assembly together as shown in FIG. 5. Note that the bolts 62 also pass through the apertures 74 in the cover plate 16. Any number of bolts and apertures may be used.

When the clutch assembly is bolted together, the spring
35 18 bears against an annular upward portion 80 of the pressure plate 58 so that the clutch is engaged, causing the

driver and driven plates 48 through 56 to be in frictional contact with each other. The spring 18 bears against or provides sufficient force to keep the plates 48 through 56 in mutual frictional contact so that torque is transmitted
5 from the flywheel 12 (or engine crankshaft) to the output shaft 14. The coefficient of friction of the carbon plates 48 through 56 increases with temperature, a desirable property due to high operating temperatures experienced during repeated engagement and disengagement of the clutch.

10 The clutch may be disengaged by stepping on a foot pedal or otherwise causing the throwout bushing 40 to move down the shaft 14, as indicated by arrow 34 in FIG. 5, so that the bushing 40 contacts the diaphragm spring 18 and forces inner periphery 32 of the spring 18 downward. This
15 action causes outer periphery 28 of the spring 18 to move upward as indicated by arrow 30, and reduces bearing forces acting on upward portion 80 of the pressure plate 58. As the bearing forces are reduced, the carbon plates 48 through 56 loosen and frictional contact is no longer maintained
20 between the plates. Loosening of the stack of plates occurs because the reduction in bearing forces allows the driver plates 52, 54 and 56 to move longitudinally along the spacing blocks 78, and the driven plates 48 and 50 to move upward due to radial slots 46. After loosening of the
25 plates 48 through 56 occurs, the clutch is disengaged and torque is no longer transmitted from the flywheel 12 to the output shaft 14.

Inside diameters 68, 70 and 72 of the driver carbon plates 52, 54 and 56, respectively, are sized to provide
30 lightweight plates. Figs. 2 and 3 show the pressure plate 58 and driver carbon plate 52 of the friction mechanism 10 that also help to reduce the weight of the clutch, permitting easier braking, less sluggish gear shifting, and greater rates of acceleration and deceleration.

35 The pressure plate 58 is mounted directly on carbon plate 52, thereby eliminating the peripheral apertures

typically used to couple the plate to the spacing blocks 78, which reduces the weight of the clutch.

As shown in Figs. 2 and 3, the pressure plate 58 has a plurality of downwardly extending lugs 82 at the bottom thereof, and the carbon plate 52 has a plurality of corresponding radial slots 84 extending a depth 86 (see Figs. 3 and 5) into the plate 52 at the top thereof. The shape of the slots 84 matches the shape of the lugs 82. Depth 86 is sufficient to provide the accurate concentric location of pressure plate 58 at any operating speed or temperature.

The radial slots 84 and lugs 82 are dimensioned and located so that the pressure plate 58 is disposed concentrically in the clutch assembly, and annular upward portion 80 is located for contact with spring 18. In other words, pressure plate 58 is kept concentrically aligned by the lugs 82 and slots 84 during operation of the clutch, and is not free to move radially, with the exception of slight movement which occurs due to clearances between the lugs 82 and slots 84.

Such clearances between the lugs 82 and slots 84 allow for the difference in thermal expansion of the materials used for the plates 52 and 58. Any desirable number of slots 84 and lugs 82 may be used. The pressure plate 58 may be easily assembled to carbon plate 52 by fitting the lugs 82 into the radial slots 84 before the clutch assembly is bolted to the flywheel 12.

FIG. 4 shows another embodiment of a pressure plate 88 and another embodiment of a driver carbon plate 90 of the present invention. The pressure plate 88 has a shaped outer periphery 92. The carbon plate 90 has a corresponding or mating recess 94 in the top thereof that is dimensional or shaped so that the pressure plate 88 will fit into the recess 94 and the shaped outer periphery 92 will match the outer periphery 95 of the recess 94. The shaped outer periphery 92 and the recess 94 may have any desirable shapes

or configurations. The pressure plate 88 is directly assembled to the plate 90 and does not use peripheral apertures. Therefore, an advantageous lightweight design is provided as explained above. Also, sufficient clearances
5 are provided between the shaped outer periphery 92 and outer periphery 95 to allow for differences in thermal expansion rates.

Referring now to FIG. 6, another embodiment of a pressure plate 96 is shown assembled to another embodiment
10 of a driver carbon plate 98. The pressure plate 96 has an annular peripheral portion 104 which engages a corresponding peripheral groove 100 in the carbon plate 98 formed by an annular lip portion 102. At least one radial slit 101 is provided in the pressure plate 96 which allows the plate 96
15 to be reduced in size at its outer periphery for insertion of extension 104 into groove 100 during assembly. The slit 101 also allows for thermal expansion of the plate 96 at operating temperatures. Also sufficient clearances are provided between portion 104 and groove 100 to allow for the
20 difference in thermal expansion of the materials used for the plates 96 and 98. The lightweight design of the plate 96 provides the advantages discussed above.

FIG. 7 shows yet another embodiment of an annular fulcrum 106, and of another embodiment of a driver carbon
25 plate 108 having an upwardly extending annular portion 112 with an annular groove 110 therein. As shown, the annular fulcrum 106 is mounted in or engages the annular groove 110. The groove 110 is of sufficient depth to assure that the annular fulcrum 106 will remain in the groove 110 during
30 assembly and all phases of operation of the clutch. Sufficient clearances are provided between the fulcrum 106 and groove 110 to allow for the difference in thermal expansion of the materials. The lightweight design of the annular pressure plate fulcrum provides the advantages
35 discussed above.

The above clutch assembly uses five carbon plates. However, the carbon-to-carbon friction mechanism 10 design of the present invention may be used with any desirable number of carbon plates, and metal plates may be used
5 instead of carbon plates, if desired. Also, the friction mechanism has particular application in automobile racing, but may be used with any type machinery.

The above description discloses the preferred embodiments of the present invention. However, persons of
10 ordinary skill in the art are capable of numerous modifications once taught these principles. Accordingly, it will be understood by those skilled in the art that changes in form and details may be made to the above-described embodiments without departing from the spirit and
15 scope of the invention.

WE CLAIM:

1. A friction mechanism for attachment to an engine flywheel comprising:

a cover attached to said flywheel;

5 a hub disposed between said cover and said flywheel;

a driven plate coupled to said hub;

a driver plate located adjacent said driven plate;

a pressure plate mounted directly on said driver plate;

and

10 a spring in contact with said pressure plate and coupled to said cover, said spring biasing said driver and driven plates into frictional contact so that said friction mechanism is engaged and torque from said flywheel is transmitted to said hub.

15

2. The friction mechanism of Claim 1 wherein said driver and driven plates are carbon plates.

3. The friction mechanism of Claim 2 wherein said
20 friction mechanism has two of said driven plates and three of said driver plates, one of said driver plates being located between said driven plates.

4. The friction mechanism of Claim 1 wherein said
25 pressure plate has downwardly extending lugs and said driven plate has slots therein, said lugs engaging said slots.

5. The friction mechanism of Claim 1 wherein said
30 pressure plate has a shaped outer periphery and said driver plate has a recess therein, said shaped outer periphery matching a shape of said recess.

6. The friction mechanism of Claim 1 wherein said
35 pressure plate has an annular peripheral portion and said driver plate has a peripheral groove therein, said peripheral portion engaging said groove.

7. The friction mechanism of Claim 1 wherein said pressure plate is an annular fulcrum and said driver plate has an annular groove therein, said annular fulcrum engaging said annular groove.

5

8. The friction mechanism of Claim 1 wherein said spring is a diaphragm spring.

9. A friction mechanism for attachment to an engine flywheel comprising:

10

a cover;

spacing blocks separating said cover from said flywheel;

bolts engaging said spacing blocks and attaching said cover to said flywheel;

15

a hub disposed between said cover and said flywheel;

a driven plate coupled to said hub;

a driver plate located adjacent said driven plate and having peripheral apertures therein, said spacing blocks engaging said peripheral apertures;

20

a pressure plate mounted directly on said driver plate; and

a spring in contact with said pressure plate and coupled to said cover, said spring biasing said driver and driven plates into frictional contact so that said friction mechanism is engaged and torque from said flywheel is transmitted to said hub.

25

10. The friction mechanism of Claim 9 wherein said driver and driven plates are carbon plates.

30

11. The friction mechanism of Claim 10 wherein said friction mechanism has two of said driven plates and three of said driver plates, one of said driver plates being located between said driven plates.

35

12. The friction mechanism of Claim 9 wherein said pressure plate has downwardly extending lugs and said driver plate has slots therein, said lugs engaging said slots.

5 13. The friction mechanism of Claim 9 wherein said pressure plate has a shaped outer periphery and said driver plate has a recess therein, said shaped outer periphery matching a shape of said recess.

10 14. The friction mechanism of Claim 9 wherein said pressure plate has an annular peripheral portion and said driver plate has a peripheral groove therein, said peripheral portion engaging said groove.

15 15. The friction mechanism of Claim 9 wherein said pressure plate is an annular fulcrum and said driver plate has an annular groove therein, said annular fulcrum engaging said annular groove.

20 16. The friction mechanism of Claim 9 wherein said spring is a diaphragm spring.

 17. The friction mechanism of Claim 9 wherein said spring is coupled to said cover by bolts.

25

 18. The friction mechanism of Claim 9 wherein said pressure plate has an annular upward portion in contact with said spring.

30 19. The friction mechanism of Claim 9 wherein said pressure plate is a metal plate.

 20. A friction mechanism for transmitting torque comprising:

35

a hub;

a driven plate coupled to said hub;

a driver plate located adjacent said driven plate;
a pressure plate mounted directly on said driver plate;

and

5 a spring in contact with said pressure plate and
biasing said driver and driven plates into frictional
contact so that said friction mechanism is engaged and
torque is transmitted from said driver plate to said hub.

21. A friction mechanism comprising:

10

a hub;

a first plate coupled to said hub;

a second plate located adjacent said first plate;

a pressure plate mounted directly on said second plate;

and

15

a spring in contact with said pressure plate and
adapted to selectively bias said first and second plates
into frictional contact so that said friction mechanism is
engaged.

FIG. 1

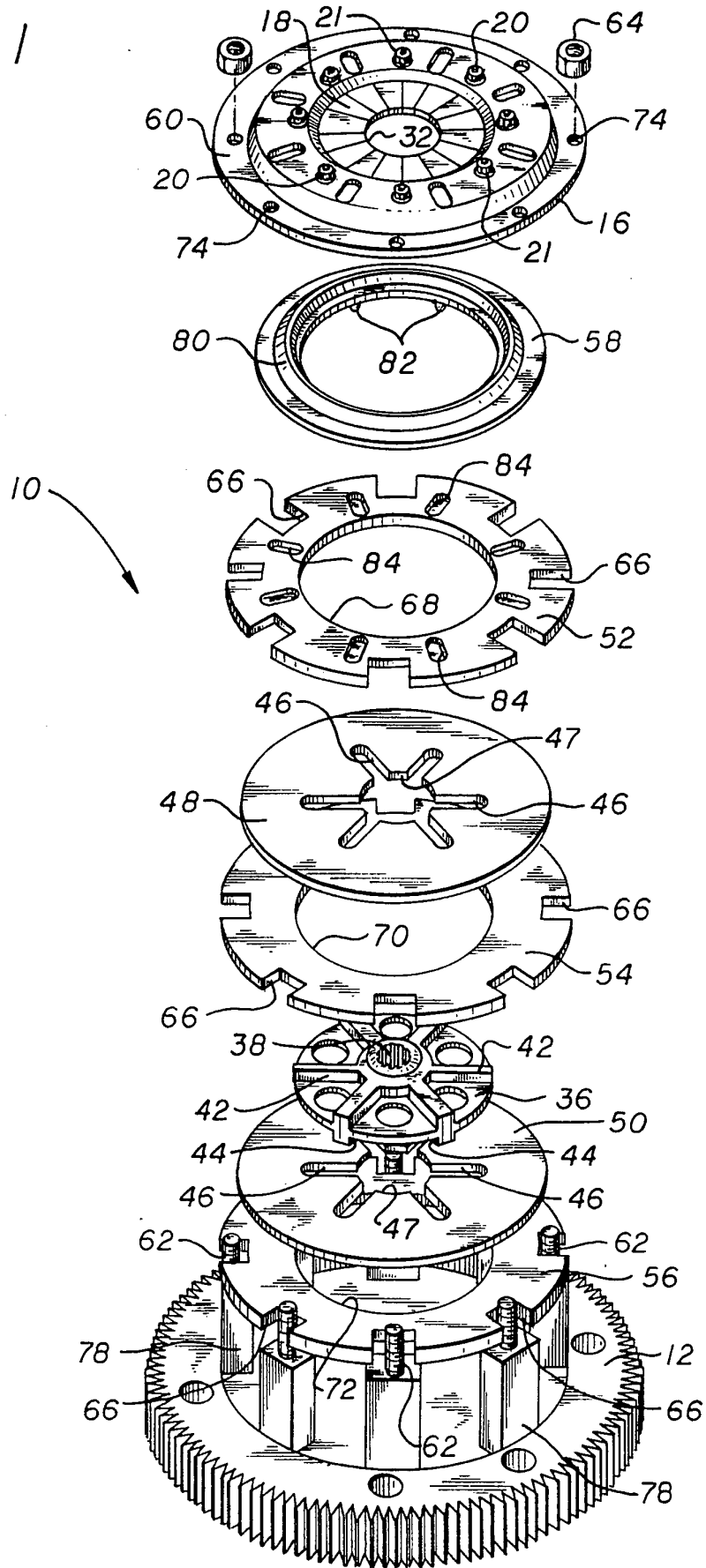

FIG. 2

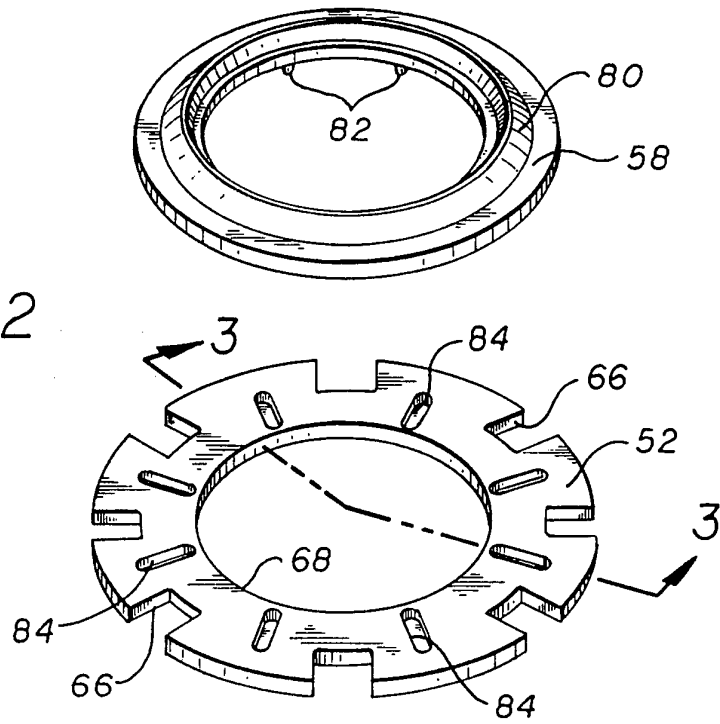

FIG. 3

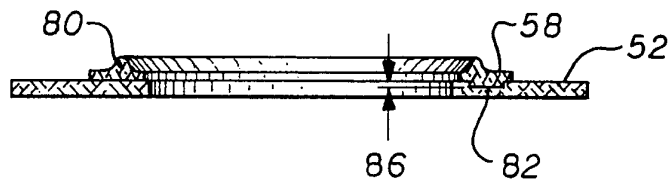
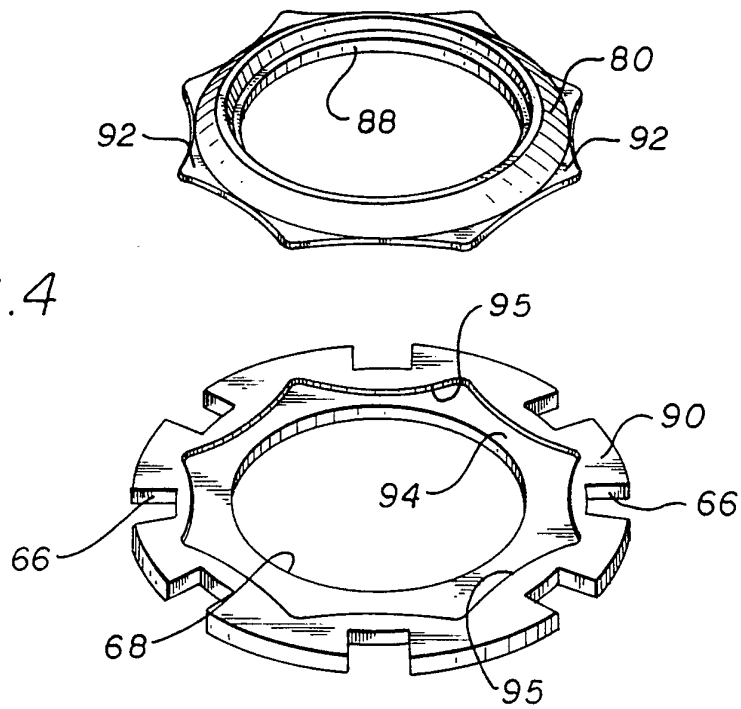

FIG. 4



INTERNATIONAL SEARCH REPORT

International application No.
PCT/US93/07513

A. CLASSIFICATION OF SUBJECT MATTER

IPC(5) :F16D 13/71,13/56,13/68
US CL :192/70.19,70.27

According to International Patent Classification (IPC) or to both national classification and IPC

B. FIELDS SEARCHED

Minimum documentation searched (classification system followed by classification symbols)

U.S. : 192/70.19,70.27,107R,109R,109A

Documentation searched other than minimum documentation to the extent that such documents are included in the fields searched

Electronic data base consulted during the international search (name of data base and, where practicable, search terms used)

C. DOCUMENTS CONSIDERED TO BE RELEVANT

| Category* | Citation of document, with indication, where appropriate, of the relevant passages | Relevant to claim No. |
|--------------|---|---------------------------------------|
| X -- Y | US,A 2,002,943 (HARTLEY) 28 MAY 1935 (See col. 1, lines 30-55, & col. 2, lines 1-49) | 1,5,6,20,21 ----- 13,14 |
| X | US,A 1,717,534 (WEMP) 18 JUNE 1929 (See page 2, lines 37-48) | 1,9,18,20,21 |
| X -- Y | US,A 1,756,428 (JONES) 29 APRIL 1930 (See page 2, lines 15-27) | 1,9,18,19, 20,21 ----- 13,14 |
| X -- Y | US,A 4,744,448 (MAYCOCK ET AL) 17 MAY 1988 (See col. 3, lines 15-39) | 1,5-8,20,21 ----- 9,18 |

Further documents are listed in the continuation of Box C. See patent family annex.

| | |
|---|--|
| * Special categories of cited documents: | *T* later document published after the international filing date or priority date and not in conflict with the application but cited to understand the principle or theory underlying the invention |
| *A* document defining the general state of the art which is not considered to be part of particular relevance | *X* document of particular relevance; the claimed invention cannot be considered novel or cannot be considered to involve an inventive step when the document is taken alone |
| *E* earlier document published on or after the international filing date | *Y* document of particular relevance; the claimed invention cannot be considered to involve an inventive step when the document is combined with one or more other such documents, such combination being obvious to a person skilled in the art |
| *L* document which may throw doubts on priority claim(s) or which is cited to establish the publication date of another citation or other special reason (as specified) | *G* document member of the same patent family |
| *O* document referring to an oral disclosure, use, exhibition or other means | |
| *P* document published prior to the international filing date but later than the priority date claimed | |

| | |
|---|--|
| Date of the actual completion of the international search 14 November 1993 | Date of mailing of the international search report NOV 16 1993 |
|---|--|

Name and mailing address of the ISA/US
Commissioner of Patents and Trademarks
Box PCT
Washington, D.C. 20231

Authorized officer *Rodney Bonck*
RODNEY BONCK
Telephone No. (703) 308-2168

Facsimile No. NOT APPLICABLE

INTERNATIONAL SEARCH REPORT

International application No.
PCT/US93/07513

| C (Continuation). DOCUMENTS CONSIDERED TO BE RELEVANT | | |
|---|--|--------------------------|
| Category* | Citation of document, with indication, where appropriate, of the relevant passages | Relevant to claim No. |
| X | US,A 3,010,555 (GARMAGER) 28 NOVEMBER 1961 (See entire document) | 1,5,20,21 |
| X | US,A 1,510,123 (WEMP) 30 SEPTEMBER 1924 (See page 1, lines 54-112) | 1,20,21 |
| -- | | ----- |
| Y | | 9,18 |
| X | US,A 4,846,326 (TILTON ET AL) 11 JULY 1989 (See entire document) | 1-3,8-11,16- 18,20,21 |
| X | US,A 4,095,683 (BAN) 20 JUNE 1978 (See col. 2, lines 35, to col. 3, line 38) | 1,4,8,20,21 |