

N. O. GOLDSMITH & J. METZGER.  
 GUARD RAIL CLAMP.  
 APPLICATION FILED APR. 27, 1911.

997,991.

Patented July 18, 1911.

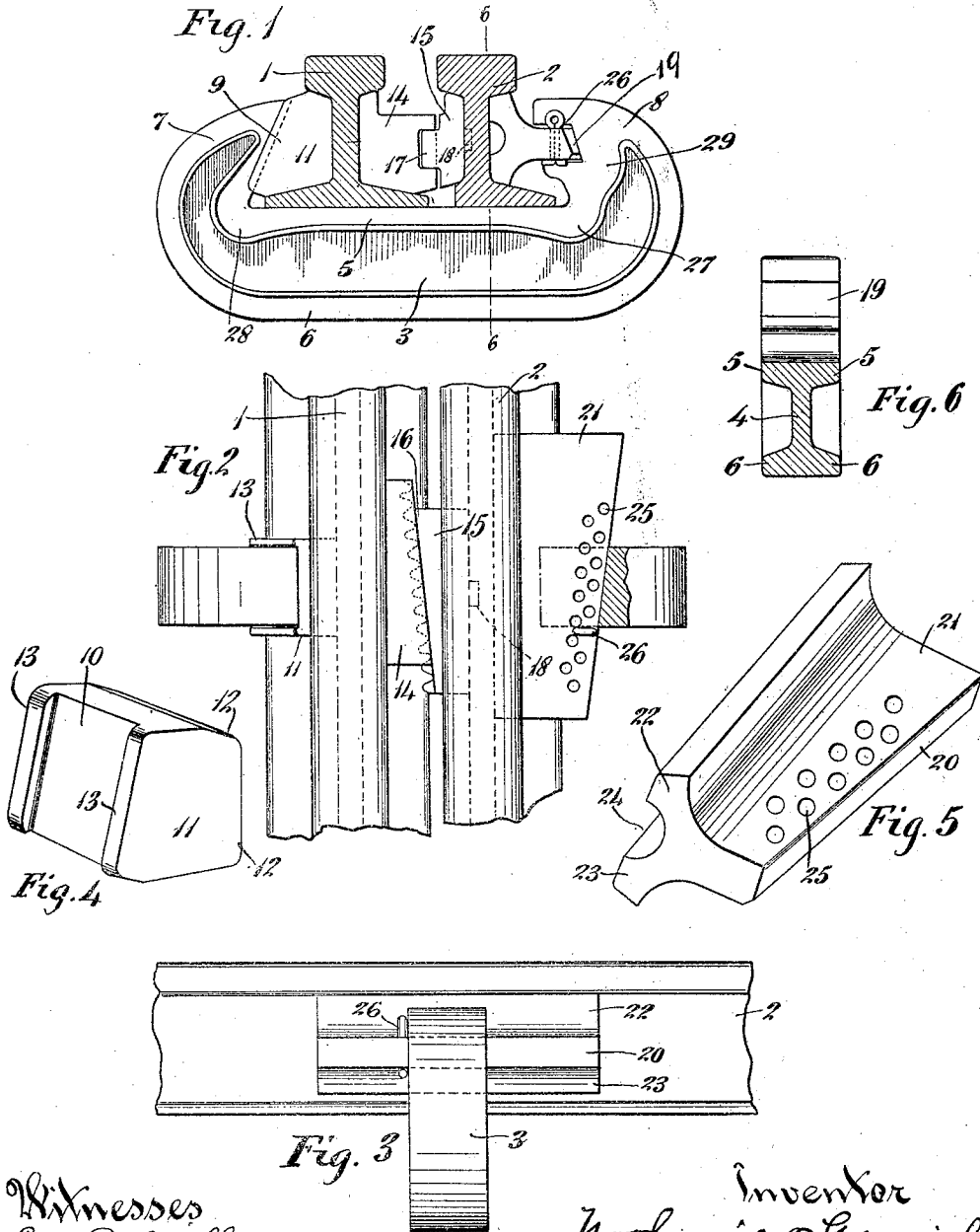

Witnesses  
 Carl H. Griffin  
 J. Smith

Inventor  
 Nathaniel O. Goldsmith  
 John Metzger  
 by Alfred M. Allen  
 Attorney

# UNITED STATES PATENT OFFICE.

NATHANIEL O. GOLDSMITH AND JOHN METZGER, OF NORWOOD, OHIO, ASSIGNORS TO  
THE WEIR FROG COMPANY, OF NORWOOD, OHIO, A CORPORATION OF OHIO.

## GUARD-RAIL CLAMP.

997,991.

Specification of Letters Patent. Patented July 18, 1911.

Application filed April 27, 1911. Serial No. 623,736.

To all whom it may concern:

Be it known that we, NATHANIEL O. GOLDSMITH and JOHN METZGER, citizens of the United States, and residents of the city of Norwood, in the county of Hamilton and State of Ohio, have invented certain new and useful Improvements in Guard-Rail Clamps, of which the following is a full, clear, and exact description, reference being had to the accompanying drawings, forming a part of this specification.

The object of our invention is to provide an effective, strong and durable clamp for locking the guard rail to the main rail in railway constructions, whereby the yoke may be readily and easily applied and may be adapted for use with rails of different weights and thicknesses of web, without the necessity of supplying yokes for each size and weight of rail.

Another object is to supply a yoke which shall be as light as possible, and at the same time shall be so reinforced at the points of greatest strain that its durability and efficiency shall be fully equal to those of much heavier and more bulky constructions.

Other features of advantage and novelty will be more fully pointed out in the course of the specification and referred to in the claims.

In the drawings, Figure 1 is a side elevation of our improved clamp with the main and guard rails in transverse section. Fig. 2 is a top plan view of the same. Fig. 3 is an end view. Figs. 4 and 5 are perspective views of the clamp block and key respectively. Fig. 6 is a cross section of the yoke, taken on the lines 6, 6, of Fig. 1, looking toward the right.

1 is the main rail, and 2 the guard rail. The yoke 3 of the clamp is formed of cast metal, with a web body portion 4 and projecting flanges 5, 5, and 6, 6, as illustrated in Fig. 6 in cross section, forming an I-beam construction,—the upper flanges 5, 5, forming a broad surface upon which the rails can rest, and the lower flanges 6, 6, adding great strength to the structure. The yoke is provided with upwardly extending jaws 7 and 8, to engage and hold the clamp block and key. The inner face of the jaw 7 is beveled or inclined inwardly at 9, to engage the correspondingly beveled face 10 of the clamp block 11. This clamp block 11 is formed with an inner surface 12 to engage the web,

under surface of the head, and the upper surface of the base of the rail, and is provided with side flanges 13, 13, to engage the side faces of the yoke to prevent longitudinal displacement of the clamp block. The filling blocks 14, 15, are of the usual construction to fit between the webs of the main and guard rails to fill out the space between the rails, and these filling blocks are provided with the usual inclined surfaces 16, provided with ribs 17, to engage each other and lock the filling blocks in position, while the lug 18 is provided for one of the filling blocks to engage in a recess in the web of the guard rail to hold the blocks from longitudinal displacement. The opposite upwardly projecting jaw 8 of the yoke is provided with a horizontal beveled slot 19, to receive the beveled face 20 and the side portion 21 of the key. This key is provided with the longitudinally projecting arms 22 and 23, the outer faces of which are formed to engage under the head of the rail and upon the base of the rail respectively, thus leaving a space 24 lengthwise of the key to clear the mill marks of the rail and obtain a more rigid bearing for the key against the rail. The web of the key is provided with a series of holes 25 for the reception of a cotter pin 26, to hold the key in any varying position to which it may be driven. The upper flanges 5, 5 of the yoke are very materially thickened at 27, 28, at the corners of the supporting base of the yoke, as at this point the yoke is subjected to the greatest strain. The inner flange of the jaw 8 surrounding the beveled slot for the key is also very materially thickened at 29, as at this point the yoke is subjected to the greatest strain of the key.

The advantages of our improved guard rail yoke will be obvious from the foregoing description. The I-beam shape in cross section of the body of the yoke furnishes great strength with corresponding lightness of material. At the same time the modification of the simple I-beam, secured by the reinforcement at the base of the rail supporting surface at the corners and around the key slot, enables us to obtain the full effect of a much bulkier and weightier construction. It will also be evident that the yoke can be equally well used with rails of different weights and thicknesses of web, and that for any change in construction of rail,

the yokes already in use may be employed by merely changing one or both of the filling blocks, the clamp block or key to conform to the new surface presented by the change of the rails. In all guard rail clamps, in which the jaw of the yoke is itself made to engage the rail, any change of rails necessitates an entirely new yoke as well as the other parts of the clamp. Also with our construction, it will be obvious that the engagement of the clamp block on one side with the base of one rail, and of the key with the base of the other rail, as the key is driven to place, the clamp block and key tend to bear down upon the face of the rails and to hold them rigidly on the supporting surface of the yoke.

Having thus described our invention, what we claim as new and desire to secure by Letters Patent, is:—

1. A guard rail clamp comprising a metal yoke of I-beam construction in cross section, with upwardly extending ends to form jaws, a clamp block for one jaw, with a wedge key for the other jaw, and a pair of spacing blocks to space the rails, whereby the rails and yoke may be rigidly locked together.

2. A guard rail clamp comprising a metal yoke of I-beam construction in cross section, with upwardly extending ends to form jaws, the upper flanges of the yoke reinforced at the base of the jaws, a clamp block for one jaw, with a wedge key for the other jaw, and a pair of spacing blocks to space the rails, whereby the rails and yoke may be rigidly locked together.

3. A guard rail clamp comprising a metal

yoke of I-beam construction in cross section, with upwardly extending ends to form jaws, a clamp block for one jaw, with a key wedge for the other jaw, the key provided with arms to engage the head and base of the rail, whereby the rails and yoke may be rigidly locked together.

4. A guard rail clamp comprising a metal yoke of I-beam construction in cross section, with upwardly extending ends to form jaws, a clamp block for one jaw, with a wedge key for the other jaw, and a pair of spacing blocks to space the rails, the clamp block provided with beveled outer face to engage the yoke jaw, and inner face to engage the head and base of the main rail, whereby the rails and yoke may be rigidly locked together.

5. A guard rail clamp comprising a metal yoke of I-beam construction in cross section, with upwardly extending ends to form jaws, the upper flanges of the yoke reinforced at the base of the jaws, a clamp block for one jaw, with a wedge key for the other jaw, and a pair of spacing blocks to space the rails, the clamp block provided with a beveled outer face to engage the yoke jaw, and an inner face to engage the head and base of the rail, the wedge key being provided with arms to engage the head and base of the guard rail, whereby the rails and yoke may be rigidly locked together.

NATHANIEL O. GOLDSMITH.  
JOHN METZGER.

Witnesses:

LUNA F. LEVINGS,  
MARSTON ALLEN.