



INTERNATIONAL APPLICATION PUBLISHED UNDER THE PATENT COOPERATION TREATY (PCT)

<p>(51) International Patent Classification³ : A61F 5/47, 5/42, 1/00 A61F 13/20</p>	A1	<p>(11) International Publication Number: WO 83/ 00011 (43) International Publication Date: 6 January 1983 (06.01.83)</p>
<p>(21) International Application Number: PCT/SE82/00218 (22) International Filing Date: 16 June 1982 (16.06.82) (31) Priority Application Number: 8103903-4 (32) Priority Date: 22 June 1981 (22.06.81) (33) Priority Country: SE</p> <p>(71) Applicant (for all designated States except US): AB MEDLINE [SE/SE]; Wallingatan 37, S-111 24 Stockholm (SE). (72) Inventor; and (75) Inventor/Applicant (for US only) : BRUNDIN, Jan-Olof [SE/SE]; Skyttevägen 21, S-181 46 Lidingö (SE). (74) Agents: HAGELBERG, Torvald et al.; Patentbyrån West-Patent, Stora Nygatan 15, S-411 08 Göteborg (SE).</p>		<p>(81) Designated States: AT, AT (European patent), AU, BE (European patent), BR, CH, CH (European patent), DE, DE (Auxiliary utility model), DE (European patent), DK, FI, FR (European patent), GB, GB (European patent), JP, LU (European patent), NL, NL (European patent), NO, SE (European patent), SU, US.</p> <p>Published <i>With international search report.</i> <i>In English translation (filed in Swedish).</i></p>

(54) Title: ARRANGEMENT FOR SEALING OF BODY CANALS

(57) Abstract

Arrangement (1) for sealing body canals comprising a body (8) of a material which expands by absorbing body fluid, so that after insertion in the non-expanded state the body expands and seals off the canal. The arrangement furthermore comprises locking devices (4) which are arranged to be pressed against the walls of the body canal and thus provide an anchorage for the body. Locking devices (4) try, as a result of a spring action, to adopt in internal position in which they are designed not to exert any locking action. The locking devices are so arranged in relation to the body (8) that during expansion the latter is pressed against the locking devices and forces them outwards to an external position in which they are intended to provide a considerable locking action.

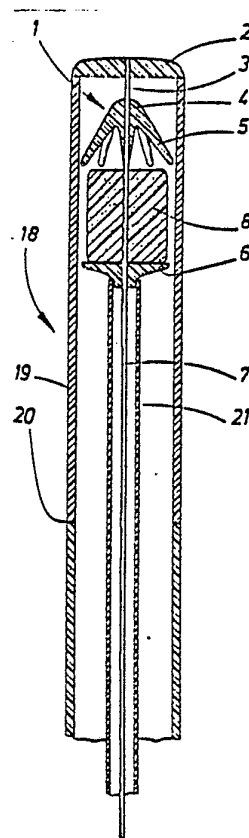

FOR THE PURPOSES OF INFORMATION ONLY

Codes used to identify States party to the PCT on the front pages of pamphlets publishing international applications under the PCT.

AT	Austria	KP	Democratic People's Republic of Korea
AU	Australia	LI	Liechtenstein
BE	Belgium	LK	Sri Lanka
BR	Brazil	LU	Luxembourg
CF	Central African Republic	MC	Monaco
CG	Congo	MG	Madagascar
CH	Switzerland	MW	Malawi
CM	Cameroon	NL	Netherlands
DE	Germany, Federal Republic of	NO	Norway
DK	Denmark	RO	Romania
FI	Finland	SE	Sweden
FR	France	SN	Senegal
GA	Gabon	SU	Soviet Union
GB	United Kingdom	TD	Chad
HU	Hungary	TG	Togo
JP	Japan	US	United States of America

Title:

Arrangement for sealing of body canals

Technical field:

The present invention relates to an arrangement for sealing body canals comprising a body made of a material which swells on absorption of body fluid so that after introduction in the non-expanded state it swells and seals the canal. The arrangement furthermore comprising locking devices arranged to be pressed against the walls of the body channels and thus bring about anchorage of the body.

Background:

The blockage of body canals by means of expandable bodies has been proposed previously. Such blockage of canals and cavities in the human or animal body can be justified for contraceptive purposes, the oviducts or sperm ducts being blocked, or because of disease, which necessitates blocking of a body canal. Here the appropriate canal is blocked and the pressure against the surrounding walls holds the body in position. However, in actual practice it has been observed that there is a risk that the body will make its way out of the canal, e.g. as a result of movement or being washed away, particularly during the initial period of time after insertion when it has not been able to absorb so much body fluid that it has adopted a size such as to exert a pressure against the surrounding walls in the canal. To obtain a reliable grip it has been proposed that the body should be provided with resilient locking devices of a relatively hard, resilient material which provides a locking action in respect of the surrounding walls.

Technical problem:

In spite of such locking devices it has not been possible to obtain complete security against the body being removed from the canal. One reason for this is that sealing bodies of this type are often extremely small and permit the attachment of only small, fine devices, which results in a weak spring action and thus a low locking action. In those cases the heavy duty locking devices can



be used, the draw back of too great a resistance against insertion may arise.

The solution:

At the device according to the invention the locking devices as a result of spring action try to adopt an inner position in which they are designed mainly not to exert any locking action or only a slight action. The locking devices are so arranged in relation to the expandable body that on expansion the latter is pressed against the locking devices and forces them outwards to an outer position in which they are designed to give a marked locking action.

Advantages:

The aim of the invention is to bring about retention of the body in its position which is more reliable than has been previously possible in the context concerned.

Another aim of the invention is to provide an arrangement which can be introduced to the desired position in the body channel in a safe manner and with full control over the position of the body, and at a from the locking action independent resistance against insertion.

Brief description of drawings:

Two embodiments of the invention are illustrated on the appended drawings. Fig. 1 illustrates in section the first embodiment; Fig. 2 shows a section through the second embodiment, both diagrams illustrating an initial position; Fig. 3 illustrates the first embodiment; Fig. 4 illustrates the second embodiment, with both diagrams illustrating the application mode; and Fig. 5 illustrates the arrangement firstly in an insertion stage and secondly placed in a female oviduct.

Best mode of carrying out the invention:

As shown in Fig. 1 the sealing arrangement 1 in accordance with the first embodiment is formed by a preferably circular plate 2 which is attached to the end of a thread 3. A locking device 4 with a number of wings 5 which point obliquely outwards is furthermore



attached to the thread 3 a short distance from the plate 2. A second plate 6, from which a free portion 7 of the thread proceeds, is fastened to the thread a short distance from the locking device 3 in the direction towards which the wings 5 are pointing. All the components just mentioned on the thread 3 are, like the actual thread, made of a material which is inert to the body fluids, e.g. a plastic material. The components can be attached to the thread by moulding.

Between the locking device 3 and plate 6 the thread is surrounded by a body 8 of an expandable material. This material can be a hydrogel, but a fibrous material is also suitable. However, hydrogels have proved to be particularly suitable in the said context, because a body made of a hydrogel does not, unlike a fibrous body, tend to leave any fragments behind. In addition hydrogels are inert in respect of body fluids and can be made to expand to the desired extent. Thus a volumetric expansion of 20-300%, measured linearly, can be obtained by a co-polymerisate of a hydrophilic polymer and a hydrophobic polymer, the proportions between these two polymers governing the degree of expansion. The material expands by absorbing water from the body fluid. It is for example possible to employ cross-linked polyacrylamide and polymers and co-polymers of methacrylic acid esters having at least one hydroxy group in the side chain. Suitable monomers are 2-hydroxyethyl-methacrylate, where the ester group can originate from diethylene glycol or triethylene glycol. It is for example also feasible to use 2,3-dihydroxypropyl methacrylate. It is possible to use, as the cross-linking substance, polyfunctional acrylates such as diesters or corresponding glycols, e.g. ethylene glycol, bis-methacrylate. The material in the body should be quite elastic and should be only very slightly plastic. In the unexpanded (non-hydrated) state it can be rigid and/or hard but should preferably soften on expansion.

As shown in Fig. 1 the body 8 is essentially cylindrical and has a length such that it leaves the wings 5 free to adopt an un-tensioned position. The body 8 must not be attached to the thread 3, but instead on expansion certain portions of it should be capable of movement with respect to the thread.

With the sealing arrangement in accordance with the second embodiment, in Fig. 2 and designated as 9, there is also an outer plate 10, a locking device 11 with wings 12 and an inner plate 13 together with an expandable body 14, preferably of a hydrogel. The plate 13 carries wings 15 which resemble the wings 12 and are directed obliquely outward and which face towards the body 14 like the wings 12. The said components are not held together by any thread, but comprise a single piece, preferably a piece moulded in plastic, and are held together by a rod 16 which forms part of this piece, and which thus replaces the thread 3 between the plate 2 and the plate 6 (Fig. 1). However, with the second embodiment there is also a free thread 17, the end of which is attached in plate 13 and which is appropriately moulded into the latter and thus into the whole of the said body formed by components 10-13 and 15, 16.

The sealing arrangements 1, 9 are in accordance with Figs. 1 and 2 in an initial state provided with an insertion arrangement 18. This consists firstly of an outer tube 19, which can obtain support against the plates 2 and 10 respectively and surrounds the entire arrangement. The tube 19 has two colours and exhibits a separating line 20 between the two colours. Thus the tube 19 is provided with a first zone nearest the arrangement 1, 9 having a certain colour and a second, outer zone in the second colour. The importance of the two coloured zones will be explained later. By "colour" it is not meant that the material in the tube 19, which is appropriately made of plastic, needs to be coloured in both zones, but that one zone can have the natural colour of the material.

There is also an inner tube 21 which surrounds the thread 7 and 17 respectively. This tube 21 is longer than the tube 19 and thus extends beyond the end of the tube 19 as shown in Fig. 5.

Blocking takes place by inserting the expandable body in the unexpanded state into the body canal concerned. The shape and dimensions of the body are so matched that it can be easily introduced into the canal. After introduction it absorbs liquid from the surrounding tissues and expands. By this means the canal is blocked as intended, whilst at the same time the body is firmly gripped in the canal as a result of the pressure against the surrounding walls. The material should essentially be inert with res-



pect to body fluids and the surrounding tissues, so that the body remains intact and can be removed when it has performed its function.

An important application of the arrangement is as a preventive agent for blocking the oviducts in a female or a female animal, or for blocking the sperm ducts in a man or a male animal. For blocking the oviducts of a woman the diameter of the tube 19 which encloses the actual blocking arrangement must not exceed 2 mm and for insertion in the sperm duct of a man the diameter should not exceed 1 mm. As illustrated in the diagrams the arrangement 1, 9 is enclosed by the tube 19 and should thus have a somewhat smaller diameter in the non-expanded state. After expansion the body 8 will have increased its diameter preferably by at least 40%, and appropriately by 80%.

Fig. 5 illustrates application in a woman's oviduct. The diagram shows the neck of the uterus 22 and the uterus 23 together with the two oviducts 24 and 25. On the left an arrangement 1 is shown schematically inserted in the oviduct 24 some distance inside the latter's entrance to the uterus 23. From the arrangement 1 the thread 7 extends outwards through the neck of the uterus 22 so that it can be observed to check whether the arrangement is still in place. At the same time the thread 7 can be employed to remove the arrangement.

During insertion, illustrated to the right in Fig. 5, the arrangement is placed horizontally in the tube 19, as illustrated in Fig. 1, and together with the tubes 19 and 21 is inserted through the neck of the uterus 22 through the uterus 23 and into the oviduct 25. The tube 19 is inserted to such an extent that its initial coloured zone disappears into the oviduct. Hence the separating line 20 between the zones is located roughly in the range where the oviduct enters the uterus. It is possible to observe by means of a hystroscope during insertion, that this location of the separating line has been achieved.

After the correct position has been obtained, the tube 19 is withdrawn, as can be seen extended through the neck of the uterus. On the other hand the inner tube 21 which is relatively rigid is held. This prevents the arrangement 1 accompanying the

tube 19 during removal. As soon as the arrangement 1 is exposed, as a result of tube 19 being withdrawn, the body 8 comes into contact with the body fluids and starts to absorb water. It thus increases its diameter by expansion and makes contact with the surrounding walls of the body canal. At the same time it increases in length and is pressed against the wings 5, which thus splay out.

This is illustrated in Fig. 3 and the arrangement has thus obtained an anchorage in the body channel, to some extent in that the relatively elastic and soft body 1 is pressed against its walls, which mainly provides the desired seal and ensures closure of the canal, although the position retention action is not particularly strong because the material of the body slides relatively easily against the canal walls. However, now position retention is undertaken by the wings 5, which splay out as a result of the expansion of the body, and which are of relatively hard material and engage directly in the canal walls. As soon as it can be anticipated that this locking action has been achieved, it is also possible to withdraw the tube 20 and the arrangement then adopts the state illustrated to the left in Fig. 5 where only the thread 7 emerges from the arrangement 1. If during the exposure of the arrangement 1 the tube 19 has not been completely withdrawn, then this should naturally also be removed.

The action described above also applies to the arrangement 9 in accordance with the second embodiment. However here, as described above, there is a double locking device in the form of wings 12 and 15 which splay outwards because the body 14 increases its length between them.

Hence the basic idea of the invention is to employ the expandable body for splaying out locking devices. This principle can also be employed for sealing off body channels other than those mentioned, for example in connection with haemorrhages for sealing off blood vessels. As regards dimensions and shape, the design must be adapted to suit the application envisaged. It is possible to use one or several rows of locking devices and also one or more expandable bodies. The insertion arrangement described is employed naturally only when required.

Claims:

1. Arrangement for sealing off body canals comprising a body (8; 14) made of a material which expands by absorbing body fluid, so that after insertion in the non-expanded state the body expands and seals off the canal, whereby the arrangement furthermore includes locking devices (4; 12, 15) arranged to be pressed against the walls of the body canal and thus provide an anchorage for the body, CHARACTERIZED in that the locking device or devices (4; 12, 15) as a result of spring action try to adopt an inner position in which they are designed mainly not to exert any locking action or only a slight action, and that the locking devices are so arranged in relation to the body (8; 14) that on expansion the latter is pressed against the locking devices and forces them outwards to an outer position in which they are designed to give a marked locking action.
2. Arrangement according to claim 1, CHARACTERIZED in that the body (8) is placed against a retainer (6) and that the locking device (4) is placed on the opposite side, so that when the body expands it rests against the retainer (6) whilst its other end moves in towards the locking device (14) and expands the latter by splaying out the locking elements (5) which are obliquely orientated in towards the other end of the body.
3. Arrangement according to claim 1, CHARACTERIZED in that the body (14) is located between two locking devices (11, 15) with locking elements which are orientated obliquely in towards both ends of the body, so that on expansion of the body these two ends are pressed against the locking elements and splay these outwards.
4. Arrangement according to claims 2 or 3, CHARACTERIZED in that the body encloses a thread (3) or rod (16) on which the locking device (4) and the retainer (6) and locking devices (11, 15) are attached.
5. Arrangement according to any of the preceding claims, CHARACTERIZED in that this includes an insertion arrangement which comprises an external tube (19) which during insertion is arranged to surround the body (8; 14) and locking device or devices (4; 11, 15) and an internal tube or the like (21) which is arranged to be inside the outer tube (19) and to rest against the end of that por-

tion of the arrangement which comprises the body and locking device, so that the arrangement as a whole can be introduced by means of the outer tube (19) after which that part of the arrangement which comprises the body and locking device can be exposed by withdrawal of the outer tube whilst retaining the said portion in the inserted position by means of the inner tube, so that the body can absorb body fluid and expand so as to become anchored in the position adopted.

6. Arrangement according to claim 5, CHARACTERIZED in that the outer tube (19) has two areas of length, separated from each other by colour or other marking by means of a separating line (20) which forms zones, whereby the zone which comprises that part of the tube which is connected to the said portion of the arrangement is adapted, as regards its length, to the intended length of insertion of the tube from the entrance to the body canal, so that the correct depth of insertion can be established by observing when the separating line reaches the entrance to the canal.

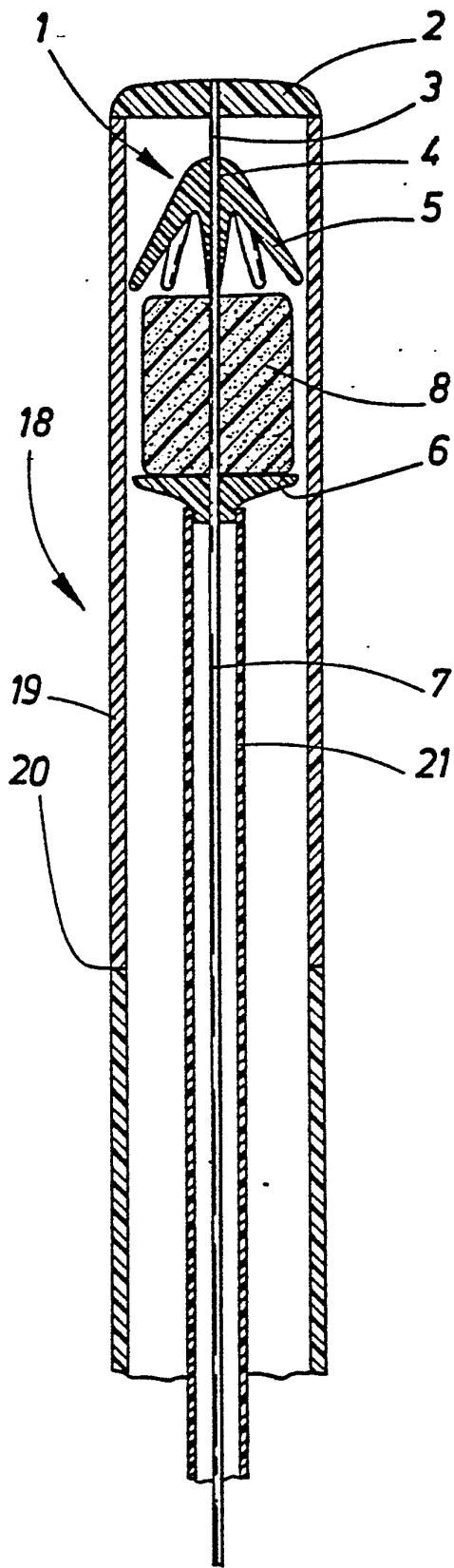

FIG.1

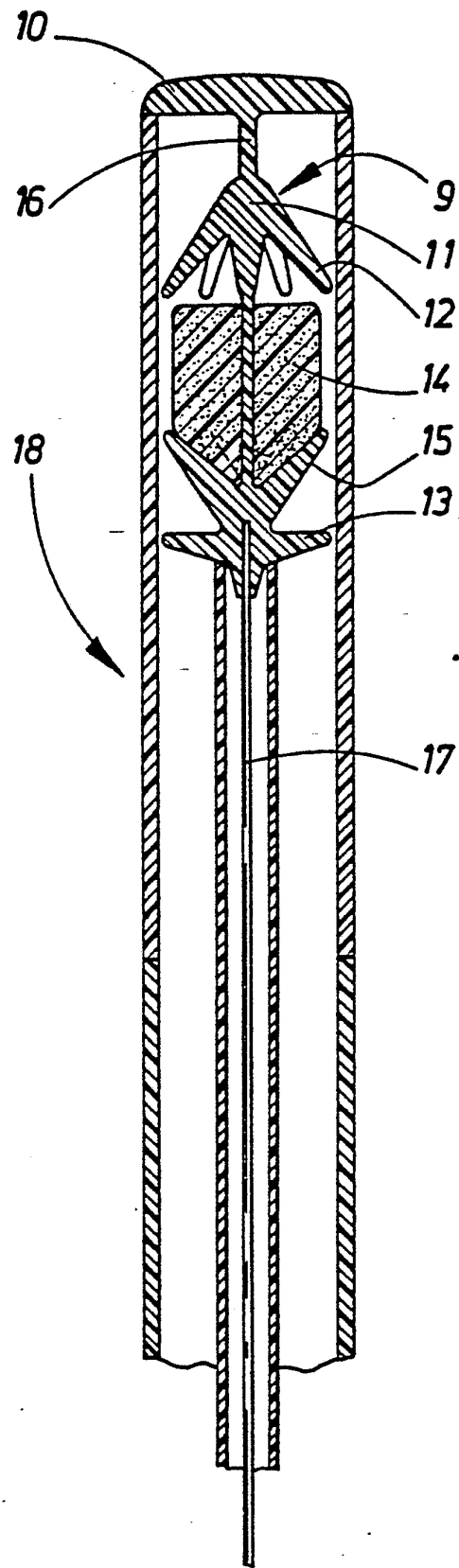
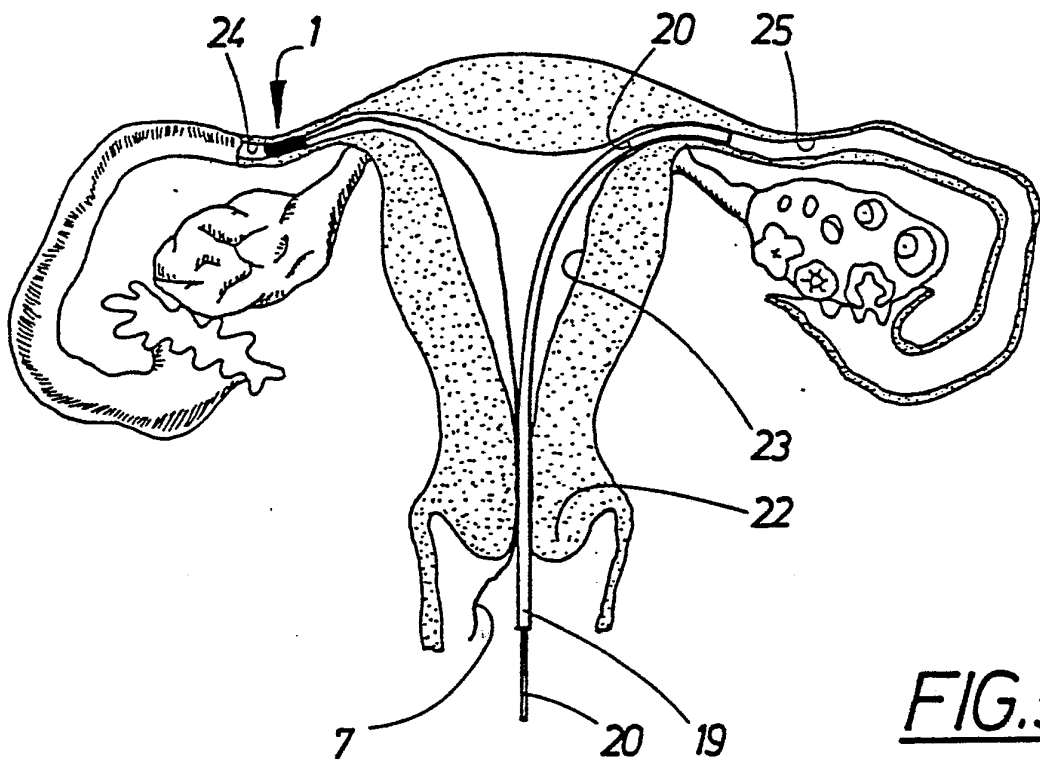
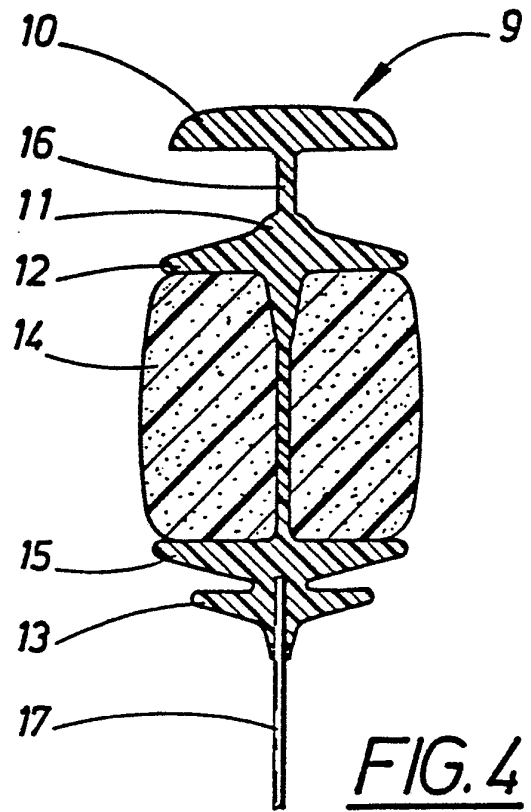
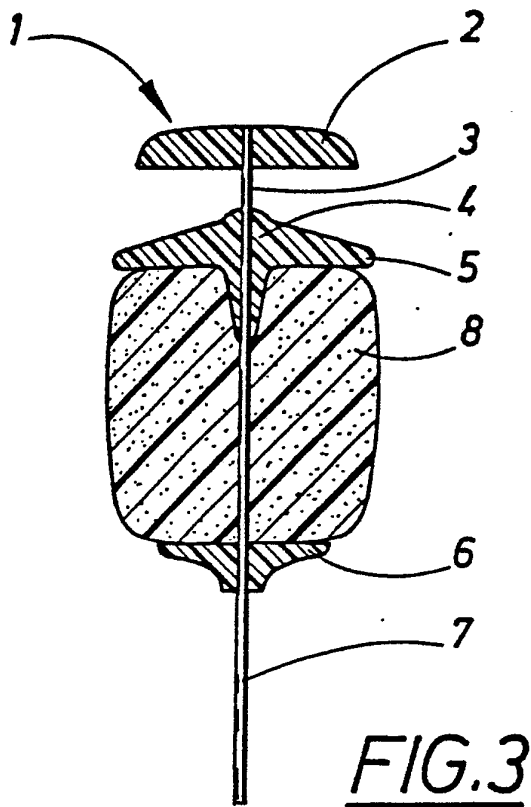
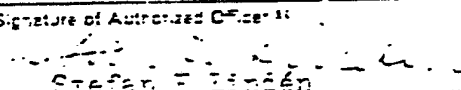

FIG.2



INTERNATIONAL SEARCH REPORT

International Application No **PCT/SE82/00218**

I. CLASSIFICATION OF SUBJECT MATTER (if several classification symbols apply, indicate all) ³				
According to International Patent Classification (IPC) or to both National Classification and IPC 3				
A 61 F 5/47, 5/42, 1/00, 13/20				
II. FIELDS SEARCHED				
Minimum Documentation Searched ⁴				
Classification System	Classification Symbols			
IPC 3	A 61 B 19/00, A 61 F 1/00, 5/42, 5/46, 5/47, 13/20, A 61 M 29/00, 29/02, 37/00			
US C1	128:1, 127, 130, 285			
Documentation Searched other than Minimum Documentation to the extent that such Documents are included in the Fields Searched ⁵				
SE, NO, DK, FI classes as above				
III. DOCUMENTS CONSIDERED TO BE RELEVANT ¹⁴				
Category ⁶	Citation of Document, ¹⁵ with indication, where appropriate, of the relevant passages ¹⁷	Relevant to Claim No. ¹⁸		
A	WO, A1, 80/02369 (AB MEDLINE) 13 November 1980	1-4		
A	WO, A1, 81/01515 (AB MEDLINE) 11 June 1981	1-4		
A	WO, A1, 80/01460 (AB TESTI) 24 July 1980	1-4		
X	DE, A1, 2 157 727 (TECNA CORP) 9 August 1973	5		
<table style="width: 100%; border: none;"> <tr> <td style="width: 50%; border: none; vertical-align: top;"> <p>¹⁴ Special categories of cited documents: 15</p> <p>"A" document defining the general state of the art which is not considered to be of particular relevance</p> <p>"E" earlier document but published on or after the international filing date</p> <p>"L" document which may throw doubts on priority claims or which is cited to establish the publication date of another citation or other special reason (as specified)</p> <p>"O" document referring to an oral disclosure, use, exhibition or other means</p> <p>"P" document published prior to the international filing date but later than the priority date of a claim</p> </td> <td style="width: 50%; border: none; vertical-align: top;"> <p>"T" later document published after the international filing date or priority date and not in conflict with the application but cited to understand the principle or theory underlying the invention</p> <p>"X" document of particular relevance: the claimed invention cannot be considered novel or cannot be considered to involve an inventive step</p> <p>"Y" document of particular relevance: the claimed invention cannot be considered to involve an inventive step when the document is compared with one or more other such documents, such combination being obvious to a person skilled in the art</p> <p>"Z" document member of the same patent family</p> </td> </tr> </table>			<p>¹⁴ Special categories of cited documents: 15</p> <p>"A" document defining the general state of the art which is not considered to be of particular relevance</p> <p>"E" earlier document but published on or after the international filing date</p> <p>"L" document which may throw doubts on priority claims or which is cited to establish the publication date of another citation or other special reason (as specified)</p> <p>"O" document referring to an oral disclosure, use, exhibition or other means</p> <p>"P" document published prior to the international filing date but later than the priority date of a claim</p>	<p>"T" later document published after the international filing date or priority date and not in conflict with the application but cited to understand the principle or theory underlying the invention</p> <p>"X" document of particular relevance: the claimed invention cannot be considered novel or cannot be considered to involve an inventive step</p> <p>"Y" document of particular relevance: the claimed invention cannot be considered to involve an inventive step when the document is compared with one or more other such documents, such combination being obvious to a person skilled in the art</p> <p>"Z" document member of the same patent family</p>
<p>¹⁴ Special categories of cited documents: 15</p> <p>"A" document defining the general state of the art which is not considered to be of particular relevance</p> <p>"E" earlier document but published on or after the international filing date</p> <p>"L" document which may throw doubts on priority claims or which is cited to establish the publication date of another citation or other special reason (as specified)</p> <p>"O" document referring to an oral disclosure, use, exhibition or other means</p> <p>"P" document published prior to the international filing date but later than the priority date of a claim</p>	<p>"T" later document published after the international filing date or priority date and not in conflict with the application but cited to understand the principle or theory underlying the invention</p> <p>"X" document of particular relevance: the claimed invention cannot be considered novel or cannot be considered to involve an inventive step</p> <p>"Y" document of particular relevance: the claimed invention cannot be considered to involve an inventive step when the document is compared with one or more other such documents, such combination being obvious to a person skilled in the art</p> <p>"Z" document member of the same patent family</p>			
IV. CERTIFICATION				
Date of the Actual Completion of the International Search: ¹	Date of Mailing of this International Search Report: ²			
1982-09-09	1982-09-13			
International Searching Authority: ³	Signature of Authorized Officer: ⁴			
Swedish Patent Office	 Stefan E. Lindén			