

April 2, 1963

L. S. WATLINGTON

3,083,374

TISSUE WETTING DEVICE

Filed Oct. 15, 1962

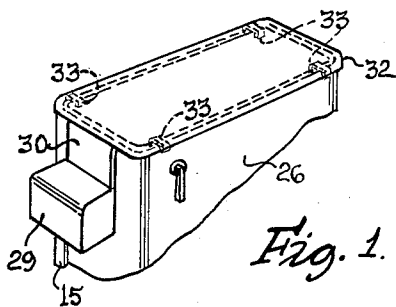

Fig. 1.

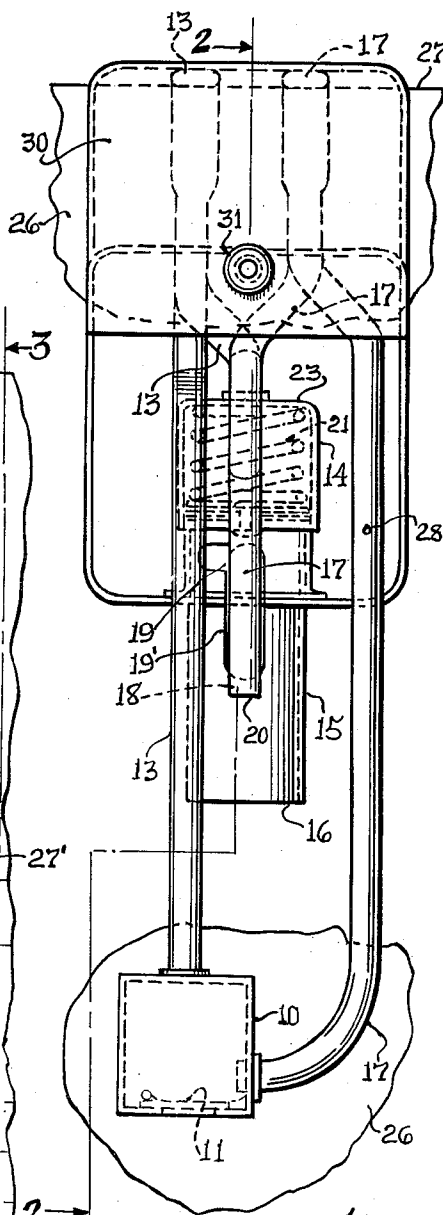

Fig. 3.

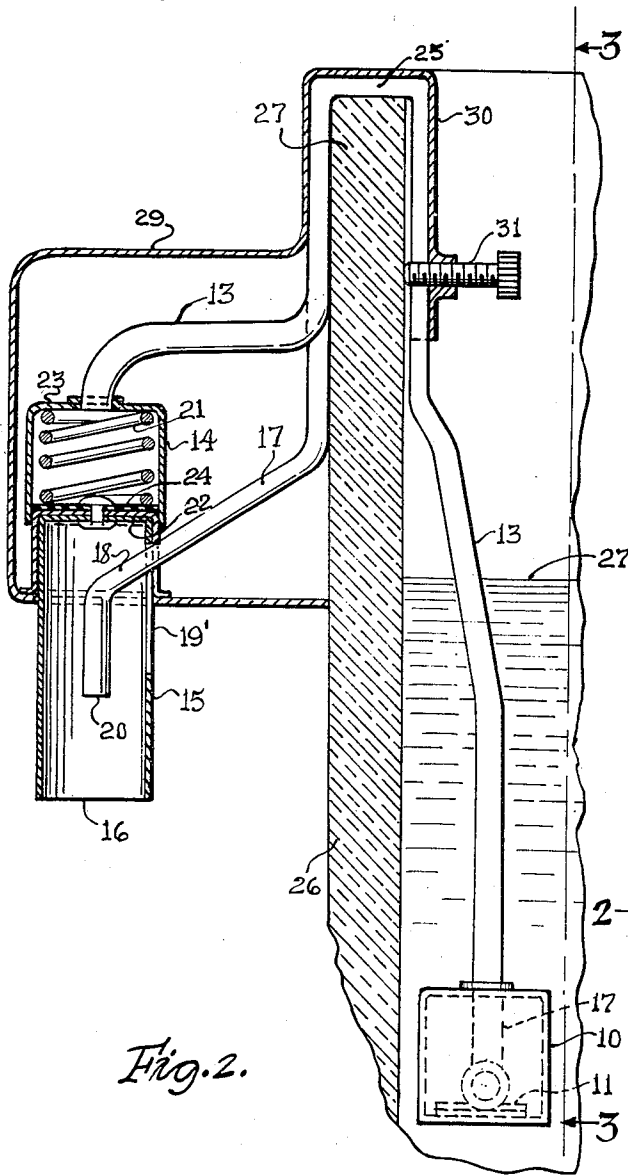

Fig. 2.

INVENTOR.  
**LEE S. WATLINGTON**  
BY *Shreeley Shreeley*  
HIS ATTORNEYS.

1

3,083,374  
**TISSUE WETTING DEVICE**  
 Lee S. Watlington, Bloomington, Ill.  
 Filed Oct. 15, 1962, Ser. No. 230,403  
 6 Claims. (Cl. 4-1)

My invention relates to certain new and useful improvements in a tissue wetting device for toilet purposes.

An object of the invention is to provide a simple and improved arrangement for wetting a tissue or the like by water drawn from the flush tank with which my device is associated.

Another and equally important object of the invention is the provision of trapping a predetermined amount of water in a trap submerged in the water of a flush tank and expelling the trapped water at a point exterior of the tank for use in wetting a tissue or the like for toilet purposes, all of which is accomplished by a manual operation of an arrangement for admitting water into the trap and expelling the same therefrom.

Other objects will appear hereinafter.

The invention consists in the novel combination and arrangement of parts to be hereinafter described and claimed.

The invention will be best understood by reference to the accompanying drawings showing the preferred form of construction, and in which:

FIG. 1 is a fragmentary perspective view of a flush tank showing my invention associated therewith;

FIG. 2 is a fragmentary sectional detail view taken on line 2-2 of FIG. 3;

FIG. 3 is a fragmentary sectional detail view taken on line 3-3 of FIG. 2, with certain portions broken away for illustrative purposes.

While my present invention is stated as being useful for wetting tissue for toilet purposes, it is to be understood that the invention may be used for wetting cloth or the like.

To accomplish the several objects of my invention, I provide a water trap 10 which is closed except for a suitable check valve 11 which, when open, permits water to be drawn into the trap and, when closed, permits the trapped water to be expelled therefrom. A first conduit 13 opens communication between the trap 10 and a cylinder 14. Longitudinally movable within this cylinder is a plunger 15 having one end 16 open. A second conduit 17 opens communication between the plunger 15 and the trap 10. The end portion 18 of the conduit 17 projects through a slot 19 formed in the plunger the outlet end 20 of such portion 18 being concentric with the open end 16 of the plunger when the plunger is manually moved to its innermost position with respect to the cylinder 14. The long portion 19' of the bayonet slot 19 permits the plunger 15 to be moved longitudinally of its length for purposes herein stated.

The coil spring 21 is arranged within the cylinder 14 between the top 22 of the plunger and the top wall 23 of the cylinder. A proper seal 24 of pliable material provides a seal between the cylinder 14 and the plunger 15.

The conduits 13 and 17 each have an intermediate portion indicated at 25 formed substantially U-shaped to afford a mounting of the trap 10 in submerged position in a flush tank 26, as well as to support the cylinder and plunger exteriorly of the flush tank.

To accomplish this, the U-shaped portions of the conduits 13 and 17 are positioned to embrace the adjacent wall portion 27 of the flush tank 26. For purposes hereinafter mentioned there is formed in the conduit 17 at a point above the water level 27' in the flush tank 26 a relatively small vent 28.

To complete the invention, an enclosure 29 is provided

2

for the cylinder 14 and upper portion of the plunger 15. This cylinder 29 has a U-shaped portion 30 which is positioned over the wall portion 27 of the flush tank 26. The U-shaped portion 30 carries a set screw 31 by means of which the device is firmly attached to the wall 27 of the flush tank. The cover 32 of the flush tank is elevated by suitable rubber clips 33 to support the cover 32 in a level condition above the U-shaped portion 30 of the enclosure 29.

In use, it is desirable that the device be positioned on the flush tank at a point within convenient reach.

In the initial operation of the device, the trap 10 is charged with a predetermined amount of water.

This is accomplished by manually moving the plunger inwardly and then letting the same move in an opposite direction under the action of the spring 21 to draw in the said predetermined amount of water into the trap 10 in a manner now to be more specifically described. With the tank 10 now preliminarily charged with water from the tank 26, the device is ready to be operated for the purpose of wetting a tissue or other article. This is accomplished by pressing a tissue or the like against the open end 16 of the plunger 15 in an upward direction, moving the plunger against the action of the spring 21. Such movement of the plunger within the cylinder 14 will create an air pressure through the conduit 13 so as to force the water trapped in the trap 10 through the conduit 17 and out its discharge end 20 onto the tissue or other article.

After the tissue or like article has thus been wet, it is withdrawn from engagement with the plunger 15, permitting the plunger to be projected outwardly with respect to the cylinder 14 under action of the spring 21. In this outward movement of the plunger 15, a vacuum is created in the cylinder 14 and conduit 13 which effects opening of the check valve 11, allowing a predetermined amount of water to enter the trap 10. Upon completion of the outward movement of the plunger 15 when in a dormant position, the trap 11 will be closed and the water trapped in the trap 10. The device is now set up for another operation of wetting the tissue or other article in the manner hereinbefore described.

To prevent possible siphoning of water through the conduit 17, there is formed therein above the water level 27' the vent 28 hereinbefore referred to. This vent 28 is relatively small and serves as a vacuum breaker. The size of the vent is such that it has little effect on the amount of water forced through the conduit 17.

The provision of the bayonet slot 19 hereinbefore referred to is to releasably latch the plunger 15 to the conduit 17 by rotating the plunger 15 relative to the cylinder 14. This will prevent operation of the plunger as long as the same remains in such position.

The enclosure 29 may be attractively designed and colored to conform to the style and color of the flush tank.

While I have illustrated and described the preferred form of construction for carrying my invention into effect, this is capable of variation and modification without departing from the spirit of the invention. I therefore do not wish to be limited to the precise details of construction set forth, but desire to avail myself of such variations and modifications as come within the scope of the appended claims.

Having thus described my invention, what I claim as new and desire to protect by Letters Patent is:

1. A device for wetting a tissue or the like for toilet purposes including
  - (a) a water trap submerged in a body of water in a flush tank,

3

- (b) a check valve for said trap for admitting water thereto when said check valve is open,
  - (c) a pump cylinder,
  - (d) a first conduit providing communication between said cylinder and said water trap,
  - (e) a hollow plunger movable in said cylinder and providing together with said cylinder a chamber,
  - (f) the inner end of said plunger being closed and the outer end being open,
  - (g) a second conduit providing connection between the plunger and the water trap,
  - (h) and a spring in said chamber between the plunger and the cylinder and acting on said plunger to project the same in an outward direction from the cylinder to create a vacuum in the cylinder and said first conduit to draw water through said check valve into said trap,
  - (i) said plunger, when moved inwardly against said spring by manual engagement of a tissue or the like pressed against the plunger, adapted to create an expelling pressure through said first conduit to close said check valve and expel water from the trap through said second conduit into the plunger to wet said tissue or the like.
2. A device for wetting a tissue or the like for toilet purposes including
- (a) a water trap submerged in a body of water in a flush tank,
  - (b) a check valve for said trap for admitting water thereto when said check valve is open,
  - (c) a pump cylinder,
  - (d) a first conduit providing communication between said cylinder and said water trap,
  - (e) a hollow plunger movable in said cylinder and providing together with said cylinder a chamber,
  - (f) the inner end of said plunger being closed and the outer end being open,
  - (g) a second conduit providing connection between the plunger and the water trap,
  - (h) a spring in said chamber between the plunger and the cylinder and acting on said plunger to project the same in an outward direction from the cylinder to create a vacuum in the cylinder and said first conduit to draw water through said check valve into said trap,
  - (i) said plunger, when moved inwardly against said spring by manual engagement of a tissue or the like pressed against the plunger, adapted to create an expelling pressure through said first conduit to close said check valve and expel water from the trap through said second conduit into the plunger to wet said tissue or the like,
  - (j) means for supporting said trap in submerged position in the water of said tank with the cylinder and plunger disposed exteriorly of said tank.
3. A device for wetting a tissue or the like for toilet purposes including
- (a) a water trap submerged in a body of water in a flush tank,
  - (b) a check valve for said trap for admitting water thereto when said check valve is open,
  - (c) a pump cylinder,
  - (d) a first conduit providing communication between said cylinder and said water trap,
  - (e) a hollow plunger movable in said cylinder and providing together with said cylinder a chamber,
  - (f) the inner end of said plunger being closed and the outer end being open,
  - (g) a second conduit providing connection between the plunger and the water trap,
  - (h) and a spring in said chamber between the plunger and the cylinder and acting on said plunger to project the same in an outward direction from the cylinder to create a vacuum in the cylinder and said first

4

- conduit to draw water through said check valve into said trap,
  - (i) said plunger, when moved inwardly against said spring by manual engagement of a tissue or the like pressed against the plunger, adapted to create an expelling pressure through said first conduit to close said check valve and expel water from the trap through said second conduit into the plunger to wet said tissue or the like,
  - (j) said first and second conduits each having an intermediate U-shaped portion adapted to be hooked over a wall of said tank for supporting said trap in submerged position in the water of said tank with the cylinder and plunger exterior of said tank.
4. A device for wetting a tissue or the like for toilet purposes including
- (a) a water trap submerged in a body of water in a flush tank,
  - (b) a check valve for said trap for admitting water thereto when said check valve is open,
  - (c) a pump cylinder,
  - (d) a first conduit providing communication between said cylinder and said water trap,
  - (e) a cup-shaped plunger movable in said cylinder and providing together with said cylinder a chamber,
  - (f) the inner end of said plunger being closed and the outer end being open,
  - (g) a second conduit providing connection between the plunger and the water trap,
  - (h) and means in said chamber between the plunger and the cylinder and acting on said plunger to project the same in an outward direction from the cylinder to create a vacuum in the cylinder and said first conduit to draw water through said check valve into said trap,
  - (i) said plunger, when moved inwardly against said means by manual engagement of a tissue or the like pressed against the plunger, adapted to create an expelling pressure through said first conduit to close said check valve and expel water from the trap through said second conduit into the plunger to wet said tissue or the like.
5. A device for wetting a tissue or the like for toilet purposes including
- (a) a water trap submerged in a body of water in a flush tank,
  - (b) a check valve for said trap for admitting water thereto when said check valve is open,
  - (c) a pump cylinder,
  - (d) a first conduit providing communication between said cylinder and said water trap,
  - (e) a hollow plunger movable in said cylinder and providing together with said cylinder a chamber,
  - (f) the inner end of said plunger being closed and the outer end being open,
  - (g) a second conduit providing connection between the plunger and the water trap,
  - (h) and a spring in said chamber between the plunger and the cylinder and acting on said plunger to project the same in an outward direction from the cylinder to create a vacuum in the cylinder and said first conduit to draw water through said check valve into said trap,
  - (i) said plunger, when moved inwardly against said spring by manual engagement of a tissue or the like pressed against the plunger, adapted to create an expelling pressure through said first conduit to close said check valve and expel water from the trap through said second conduit into the plunger to wet said tissue or the like,
  - (j) said plunger being adapted to be rotated with respect to said cylinder and said plunger having a bayonet slot formed therein adapted to receive an

5

adjacent portion of said second conduit to releasably hold said plunger against axial movement.

6. A device for wetting a tissue or the like for toilet purposes including

(a) a water trap submerged in a body of water in a flush tank, 5

(b) a check valve for said trap for admitting water thereto when said check valve is open,

(c) a pump cylinder,

(d) a first conduit providing communication between said cylinder and said water trap, 10

(e) a cup-shaped plunger movable in said cylinder and providing together with said cylinder a chamber,

(f) the inner end of said plunger being closed and the outer end being open, 15

(g) a second conduit providing connection between the plunger and the water trap,

(h) and means in said chamber between the plunger and the cylinder and acting on said plunger to project the same in an outward direction from the cylinder to create a vacuum in the cylinder and said 20

6

first conduit to draw water through said check valve into said trap,

(i) said plunger, when moved inwardly against said means by manual engagement of a tissue or the like pressed against the plunger, adapted to create an expelling pressure through said first conduit to close said check valve and expel water from the trap through said second conduit into the plunger to wet said tissue or the like,

(j) said plunger being adapted to be rotated with respect to said cylinder and said plunger having a bayonet slot formed therein adapted to receive an adjacent portion of said second conduit to releasably hold said plunger against axial movement.

**References Cited in the file of this patent**

**UNITED STATES PATENTS**

2,466,144	Adams -----	Apr. 5, 1949
2,545,338	Bowden -----	Mar. 13, 1951