

(19) **DANMARK**

(10) **DK/EP 2944242 T3**



Patent- og  
Varemærkestyrelsen

(12) **Oversættelse af  
europæisk patentskrift**

- 
- (51) Int.Cl.: **A 47 L 9/02 (2006.01)**
- (45) Oversættelsen bekendtgjort den: **2019-11-11**
- (80) Dato for Den Europæiske Patentmyndigheds bekendtgørelse om meddelelse af patentet: **2019-08-07**
- (86) Europæisk ansøgning nr.: **15167570.9**
- (86) Europæisk indleveringsdag: **2015-05-13**
- (87) Den europæiske ansøgnings publiceringsdag: **2015-11-18**
- (30) Prioritet: **2014-05-14 IT MI20140878**
- (84) Designerede stater: **AL AT BE BG CH CY CZ DE DK EE ES FI FR GB GR HR HU IE IS IT LI LT LU LV MC MK MT NL NO PL PT RO RS SE SI SK SM TR**
- (73) Patenthaver: **New Ermes Europe S.r.l., Via Risorgimento, 19, 21020 Crosio della Valle (VA), Italien**
- (72) Opfinder: **Roschi, Riccardo, c/o NEW ERMES EUROPE S.r.l., Via Risorgimento, 19, 21020 Crosio della Valle (VA), Italien**
- (74) Fuldmægtig i Danmark: **Patrade A/S, Ceresbyen 75, 8000 Århus C, Danmark**
- (54) Benævnelse: **Sugehoved til en støvsuger eller lignende med forbedret basispladekanal**
- (56) Fremdragne publikationer:  
**EP-A2- 2 060 219**  
**WO-A1-02/26098**  
**WO-A1-2005/074778**  
**US-A1- 2005 262 659**



# DESCRIPTION

**[0001]** The present invention relates to a suction head to be mounted on an electric household appliance for performing cleaning by means of suction, such as a vacuum cleaner, an electric broom or a multi-purpose suction cleaning drum, for removing dust and/or fluids and/or dirt from a surface. In particular, the present invention relates to a suction head with a base plate having an improved base plate channel which provides optimum suction and silence level characteristics.

**[0002]** As is known, a vacuum cleaner, an electric broom or a similar electric household appliance for performing cleaning by means of suction comprises a suction head for removing dust, dirt or fluids from a surface. In the sector of electric household appliances, a suction head is generally referred to by the term "brush" or "nozzle". For the purpose of the present description, therefore, the terms "suction head" and "brush" or "nozzle" are considered to be equivalent. Again for the purpose of the present invention, the term "vacuum cleaner" will be used with a broad meaning so as to include all those apparatus, for professional or domestic use, which perform cleaning by means of suction. Therefore, the term "vacuum cleaner" will comprise a vacuum cleaner, an electric broom, a so-called multi-purpose suction cleaning drum, a centralized suction system for domestic or industrial use and a steam emission and suction apparatus.

**[0003]** Basically a known brush comprises a base plate shaped so as to have at least one base plate channel open towards a surface to be cleaned, a suction channel which, during use, is formed together with the base plate and is in fluid communication with the base plate, and optionally a covering body which can be connected to the base plate / suction channel assembly. The other end of the suction channel communicates with a suction tube usually via a rotatable joint. Also known are suction heads in which the suction channel, during use, is formed together with the covering body.

**[0004]** In order to avoid an incorrect interpretation of certain expressions which will be frequently used during the course of the present description and in the claims, a number of definitions are provided hereinbelow. These definitions will also be used further below with specific reference to the figures.

- The expression "inlet area of the suction duct" will be understood as meaning substantially the footprint of the base plate channel in a plane corresponding to the surface to be cleaned;
- the expression "width" of a suction head, will be understood as meaning the maximum dimension (or ground footprint) of a suction head without the covering body and calculated substantially parallel to a longitudinal axis of the base plate channel;
- the expression "suction efficiency" will be understood as meaning essentially the ratio, in percentage terms, between vacuumed material and material to be vacuumed; the vacuuming tests are carried out as stipulated in the standard EN 60312-1:2013-05;

- the "silence level" of a vacuum cleaner suction head is determined depending on whether there is an increase or reduction in the noise of the brush and vacuum cleaner assembly compared to the vacuum cleaner alone; the more the noise of a vacuum cleaner with brush increases compared to vacuum cleaner without brush, the more the suction head is considered to be noisy.

**[0005]** WO 2005/074778 A1 relates to a vacuum cleaner nozzle comprising a nozzle body in which a suction plate, having an elongated suction opening, is rotatably arranged about an axis that is mainly parallel to the suction opening and mainly transverse to the direction of movement of the nozzle. The suction plate is connected to a nozzle outlet, such that the suction opening is in fluid communication with the nozzle outlet, and the nozzle body is provided with at least two wheels that are spaced apart as seen in the direction of movement of the nozzle. When the nozzle is placed on a hard surface the wheels are positioned such that a gap is created between the suction opening and the surface to be cleaned.

**[0006]** WO 02/26098 A1 describes a tool to be used for cleaning a floor by means of suction. The tool comprises a plate having a suction channel which extends across the tool transversely with respect to the direction in which the tool is displaced across the surface of the floor. A first and second working edge connect the transversely extending sides of the suction channel. Two suction openings, each with a perpendicular wall, are provided. The two openings do not form closed channels.

**[0007]** US-A-20050262659 discloses a suction head for a vacuum cleaner.

**[0008]** Although different suction heads which perform the function of removing dust and/or fluids and/or dirt from a surface in a sufficiently efficient manner are available on the market, the Applicant has noticed that there exists the need to improve the performance of the known suction heads. In particular, the Applicant has noticed the need to increase the suction efficiency and increase the silence level of the known suction heads.

**[0009]** The Applicant has discovered that the suction efficiency is increased by suitably shaping the base plate channel and, optionally, suitably defining its dimensions with respect to the width of the suction head.

According to an embodiment, the invention relates to a suction head for a vacuum cleaner or the like comprising a base plate with a base plate channel open towards a surface to be cleaned and closed by an opposite bottom surface,

- wherein said channel comprises a front edge, a rear edge, a front wall which extends from said front edge, a rear wall which extends from said rear edge and a bottom surface which closes said channel and connects said front wall and said rear wall, wherein a section of said front edge is parallel to a respective section of said rear edge,
- wherein said front wall is inclined at a first angle with respect to a vertical plane which is perpendicular to a horizontal plane in which the front edge and the rear edge of said

- channel are arranged,
- wherein said rear wall of the channel is inclined at a second angle with respect to said vertical plane,
  - wherein the magnitude of said first angle is at least three times the magnitude of said second angle,
  - wherein an intermediate part of said channel has a depth which decreases at a third angle,
  - wherein a front strip is inclined at an angle of 12°-18° with respect to a horizontal plane defined by the front edge and rear edge of the base plate channel,
  - wherein a rear strip comprises an inclined part which is inclined at an angle of 12°-18° with respect to the horizontal plane, and
  - wherein said base plate channel has closed ends.

**[0010]** In one embodiment, the magnitude of the first angle is about 7° and the magnitude of the second angle is about 2°.

**[0011]** In one embodiment, an intermediate part of the channel has a depth which decreases at a third angle comprised between 5° and 8°.

**[0012]** The present invention will become clearer from the following detailed description, provided purely by way of a non-limiting example, to be read with reference to the accompanying drawings, in which:

- Figure 1 shows a schematic cross-sectional view of a suction head according to an embodiment of the present invention;
- Figures 2a and 2b are two bottom plan views of a base plate of a suction head according to an embodiment of the present invention;
- Figure 3 is a side view of the base plate shown in Figures 2;
- Figures 4A1, 4A2, 4A3, 4A4 and 4A5 are cross-sections along the lines, A1-A1, A2-A2, A3-A3, A4-A4 and A5-A5 of Figure 2a, respectively; and
- Figures 5B1 and 5B2 are longitudinal sections along the lines B1-B1 and B2-B2 of Figure 2a, respectively.

**[0013]** In the various figures, for the sake of clarity, some components considered to be not essential for the present invention have been omitted. In particular, the covering body is not shown. The pedal and the associated control mechanism for moving a bristled support or a rubber fin which might be present in some embodiments are likewise not shown. The suction head is denoted overall by the reference number 1.

**[0014]** With reference to the various figures, the suction head 1 comprises a base plate 2 with at least one base plate channel 3 open downwards, a curved and suitably shaped suction

channel 4 and a rotatable joint 5 rotating about an axis 6. The assembly consisting of the channel 3, the channel 4 and the joint 5 forms the suction duct 7.

**[0015]** The base plate 2 and the base plate channel 3 are described in greater detail hereinbelow.

**[0016]** For greater clarity, the cross-sectional lines are shown in Figure 2a together with some reference numbers. Figure 2b shows, more fully, the reference numbers of the base plate 2 and the associated channel 3.

**[0017]** The base plate 2 has a more or less rectangular shape with rounded corners. It has a greater dimension (length)  $L_2$  and a smaller dimension (width)  $W_2$ . The channel 3 of the base plate extends substantially parallel to the length  $L_2$  of the base plate 2.

**[0018]** The base plate channel 3 extends substantially over the entire length  $L_2$  of the base plate, from one end to the other. The shape of the base plate channel 3, in plan view, has a front edge 31 which is substantially straight and parallel to the front edge 21 of the base plate 2. The rear edge 32 of the base plate channel 3 is parallel to the rear edge 22 of the base plate along its entire length  $L_2$  except for the ends 33 which are inclined towards the front edge 31 such that the width of the base plate channel 3 gradually diminishes. Preferably, the minimum width of the base plate channel is between 40% and 60% of its maximum width. The maximum width  $W_{32}$  of the base plate channel 3 is between 5% and 7% of the length  $L_2$  of the base plate channel 3.

**[0019]** In a preferred embodiment, the minimum width is substantially 50% of the maximum width. For example, for a base plate with  $L_2 = 253$  mm and a base plate channel 3 with a width of about  $W_{32} = 16.4$  mm, the minimum width of the base plate channel at the ends 33 is about 8.22 mm.

**[0020]** Each of the two end sections 33 of the base plate channel 3 with decreasing width has a length  $L_{33}$  (measured parallel to the front edge 21) comprised between 9% and 13% of the length of the base plate channel. Preferably it is equal to about 11.7%. In the embodiment in which the length  $L_2$  of the base plate is 253 mm, each of the sections  $L_{33}$  measures about 29 mm.

**[0021]** The front strip 34 between the front edge 21 of the base plate and the front edge 31 of the channel 3 has a smaller width and is inclined so that, during use, the suction head 1 may rotate downwards when pushed forwards. The inclination  $\alpha_{34}$  of the front strip 34 is shown in Figure 4A1.

**[0022]** Preferably, the width  $W_{34}$  of the front strip 34 is relatively small. For example (when viewing the base plate in a plan view from above) it may be comprised between 3% and 5% of the width  $W_2$  of the suction head. In one embodiment it is about 4.3% of the width  $W_2$  of the suction head 2. In the embodiment in which the length  $L_2$  of the base plate 2 is 253 mm and

the width  $W_2$  is about 54 mm, the width  $W_{34}$  of the front strip 34 may be equal to about 10.6 mm.

**[0023]** Preferably, the front strip 34 is inclined at an angle  $\alpha_{34}=12^\circ-18^\circ$  with respect to a plane H defined by the front edge 31 and rear edge 32 of the base plate channel 3. Preferably, a narrow band 35 of velvety material or the like is provided in a central position. It may be glued to the front strip 34 and optionally inset in a cavity shown, for example, in Figure 4A1.

**[0024]** The rear strip 36 between the rear edge 22 of the base plate and the rear edge 32 of the base plate channel 3 has a width  $W_{36}$  greater than the width  $W_{34}$  of the front strip 34. In one embodiment, the rear strip 36 has an inclined part 36' and a flat part 36". The inclined part 36' is configured so that, during use, the suction head 1 is able to rotate upwards when pulled backwards.

**[0025]** The width  $W_{36'}$  of the inclined part 36' of the rear strip 36 (when viewing the plate in plan view from above) may be comprised between 5% and 8% of the width  $W_2$  of the suction head. In one embodiment  $W_{36'}$  is equal to about 6.7% of the width  $W_2$  of the suction head. For example, for a base plate with a length  $L_2 = 253$  mm and width  $W_2 = 54.2$  mm,  $W_{36'}$  may be about 16.8 mm and  $W_{36''}$  may be about 10 mm.

**[0026]** Preferably, the inclined part 36' of the rear strip  $W_{36}$  is inclined at an angle  $\alpha_{36'} = 12^\circ-18^\circ$  with respect to a plane F defined by the front edge 31 and rear edge 32 of the base plate channel 3. Preferably, a narrow band 35 of velvety material or the like is provided in a central position. It may be glued to the rear strip  $W_{36}$  and optionally inset in a cavity shown, for example, in Figures 2 and 4A1.

**[0027]** The Applicant conducted numerous tests while modifying various parameters and characteristics of a known suction head and discovered that one of the characteristics which most influence positively the suction efficiency and the silence level is the inclination  $\beta$  (beta) and  $\gamma$  (gamma) of the walls 311, 321 of the base plate channel 3.

**[0028]** Firstly, according to the Applicant, the angle of inclination  $\beta$  (beta) of the front wall 311 of the base channel must be greater than the angle  $\gamma$  (gamma) of inclination of the rear wall 321. The angles are calculated with respect to a vertical plane V, which is in turn perpendicular to the horizontal plane H in which the front edge 31 and the rear edge 32 of the channel 3 are arranged.

**[0029]** According to an advantageous embodiment, the angle  $\beta$  (beta) of the front wall is inclined by  $5^\circ-10^\circ$  with respect to the vertical plane V. Preferably the angle  $\beta$  (beta) is comprised between about  $6^\circ$  and  $8^\circ$ , and more preferably is about  $7^\circ$ .

**[0030]** According to an advantageous embodiment, the angle  $\gamma$  (gamma) of the rear wall is inclined by  $1^\circ-3^\circ$  with respect to the vertical plane V. Preferably the angle  $\gamma$  (gamma) is about  $2^\circ$ .

**[0031]** Therefore, preferably, the angle  $\beta$  (beta) is greater than the angle  $\gamma$  (gamma). More preferably, the angle  $\beta$  (beta) is at least twice the angle  $\gamma$  (gamma). More preferably, the angle  $\beta$  (beta) is at least three times the angle  $\gamma$  (gamma).

**[0032]** The angles  $\beta$  and  $\gamma$  are configured so that the walls 311 and 321 of the channel 3 converge upwards when the base plate 2 is in an operating configuration, with the channel 3 open towards the surface to be cleaned.

**[0033]** Preferably, the radius which joins together the bottom 37 of the channel 3 and the corresponding side walls 311 and 321 is comprised between about 1 and 3 mm. In one embodiment it is about 2.5 mm.

**[0034]** The depth of the channel 3 is denoted generally by the letter D. Specific channel depths are indicated by the letter D followed by the reference number of the section where the depth is calculated.

**[0035]** The depth D of the channel 3 remains preferably substantially constant along a first section around the opening towards the suction channel 4, decreases gradually towards the ends with a predetermined inclination along a certain intermediate section and decreases more significantly along the end sections 33 as far as the ends of the base plate channel 3.

**[0036]** Preferably, the first section with a substantially constant depth has a depth D2 which is about 6% of the length L2 of the brush. In one embodiment, with a suction head having a length L2 of about 253 mm, the first section may have a depth D2 of about 15.5 mm, namely about 6.12% of the length L2 of the suction head.

**[0037]** The first section extends towards either end of the suction head over a length of about 15 mm measured from the edge 41 of the opening towards the suction channel 4.

**[0038]** The intermediate section extends towards either end of the suction head. Starting from the centre C of the suction head, the inclined intermediate section starts from a distance of about 47 mm and terminates at a distance from the centre of about 107 mm. More generally, the intermediate section terminates at a distance from the centre of the suction head equal to about 85% of half the length (L2/2) of the suction head.

**[0039]** Preferably, the intermediate section is inclined at an angle  $\delta$  (delta) of 5-8°, preferably 6-7° and even more preferably of about 6.5°.

**[0040]** The Applicant has carried out various tests to check the suction performance of the suction head according to the present invention. In particular, the tests were carried out comparing a known suction head referred to by the trade abbreviation NE00 and commercially distributed by the same Applicant and regarded as being a suction head with optimum suction characteristics. The tests were conducted with three different air flows (25 l/s, 30 l/s and 35 l/s,

where "l/s" = litres/second).

**[0041]** Both the NE00 model and the suction head according to the invention had the same length L2=253 mm and width W2 54.2 mm. Table 1 shows the results obtained.

Table 1

Model	Air flow		
	25 l/s	30 l/s	35 l/s
NE00	67.00 %	73.00 %	78.00 %
Invention	80.00 %	77.00 %	81.00 %

**[0042]** It is evident that both with a relatively small air flow and with greater air flows the suction head according to the invention improves the suction performance. The greatest improvement of the suction performance was obtained with a flow of 25 l/s. the suction performance increased from about 67% to about 80%, thereby improving by about 20%. With an air flow of 30 l/s, the improvement was about 5%, while with an air flow of 35 l/s the improvement was about 4%.

## REFERENCES CITED IN THE DESCRIPTION

This list of references cited by the applicant is for the reader's convenience only. It does not form part of the European patent document. Even though great care has been taken in compiling the references, errors or omissions cannot be excluded and the EPO disclaims all liability in this regard.

### Patent documents cited in the description

- [WO2005074778A1 \[0005\]](#)
- [WO0226098A1 \[0006\]](#)
- [US20050262659A \[0007\]](#)

**PATENTKRAV**

1. Sugehoved (1) til en støvsuger eller lignende, omfattende en basisplade (2) med en basispladekanal (3), der er åben mod en overflade, som skal renses og lukkes ved  
5 hjælp af en modstående bundflade (37),

- hvorved kanalen (3) omfatter en frontkant (31), en bagkant (32), en frontvæg (311), som strækker sig fra frontkanten (31), en bagvæg (321), der strækker sig fra bagkanten (32), og en bundflade (37), som lukker kanalen (3)  
10 og forbinder frontvæggen (311) og bagvæggen (321), hvorved et afsnit af frontkanten (31) er parallelt med en respektiv sektion af bagkanten (32),
- hvorved frontvæggen (311) er skrånstillet en første vinkel ( $\beta$ ) i forhold til et vertikalt plan (V), der er vinkelret på et horisontalt plan (H), i hvilket frontkanten (31) og bagkanten (32) for kanalen (3) er arrangeret,
- 15 - hvorved kanalens (3) bagvæg (321) er skrånstillet en anden vinkel ( $\gamma$ ) i forhold til det vertikale plan (V),
- hvorved den første vinkels ( $\beta$ ) størrelse er mindst tre gange størrelsen af den anden vinkel ( $\gamma$ ),
- hvorved en mellemliggende del af kanalen (3) har en dybde (D), som aftager i en tredje vinkel ( $\delta$ ),  
20 - hvorved en frontliste (34) er skrånstillet en vinkel ( $\alpha_{34}$ ) på  $12^\circ - 18^\circ$  i forhold til et horisontalt plan, som er defineret af basispladekanalens (3) frontkant (31) og bagkant (32),
- hvorved en bagliste omfatter en flad del (36'') og en skrånstillet del (36'),  
25 som er skrånstillet en vinkel ( $\alpha_{36'}$ ) på  $12^\circ - 18^\circ$  i forhold til det horisontale plan, og
- hvorved basispladekanalen (3) har lukkede ender.

2. Sugehoved (1) ifølge krav 1, hvorved størrelsen af den første vinkel ( $\beta$ ) er mellem  
30  $6^\circ$  og  $8^\circ$ , og størrelsen af den anden vinkel ( $\gamma$ ) er mellem  $1^\circ$  og  $3^\circ$ .

3. Sugehoved (1) ifølge krav 1 eller 2, hvorved den tredje vinkel ( $\delta$ ) er mellem  $5^\circ$  og  $8^\circ$ .

4. Sugehoved (1) ifølge et hvilket som helst af de foregående krav, hvorved den maksimale bredde (W32) af kanalen (3) er mellem 5 % og 7 % af en længde (L2) af kanalen (3).
- 5 5. Sugehoved (1) ifølge et hvilket som helst af de foregående krav, hvorved basispladen (2) omfatter en frontliste (34) mellem en frontkant (21) på basispladen og frontkanten (31), hvorved frontlisten (34) er skrånstillet en vinkel ( $\alpha_{34}$ ), som er mellem 12° og 18°.
- 10 6. Sugehoved (1) ifølge et hvilket som helst af de foregående krav, hvorved basispladen (2) omfatter en bagliste (36) mellem en bagkant (22) på basispladen og bagkanten (32), hvorved baglisten (36) omfatter en skrånstillet del (36'), der er skrånstillet en vinkel ( $\alpha_{36'}$ ), som er mellem 12° og 18°.
- 15 7. Sugehoved (1) ifølge et hvilket som helst af de foregående krav, hvorved en maksimal bredde (W32) for kanalen (3) er mellem 5 % og 7 % af kanalens (3) længde (L2).
8. Sugehoved (1) ifølge krav 7, hvorved en mindste bredde af kanalen er mellem 40 % og 60 % af den maksimale bredde (W32).
- 20 9. Sugehoved (1) ifølge krav 1, hvorved frontlisten (34) omfatter et smalt bånd (35) af fløjsblødt materiale i en central position.
- 25 10. Sugehoved (1) ifølge krav 1, hvorved baglistens skrånstillede del (36') omfatter et smalt bånd af fløjsblødt materiale i en central position.
11. Sugehoved (1) ifølge krav 9 eller 10, hvorved det smalle bånd (35) af fløjsblødt materiale er indsat i en udsparring.

DRAWINGS

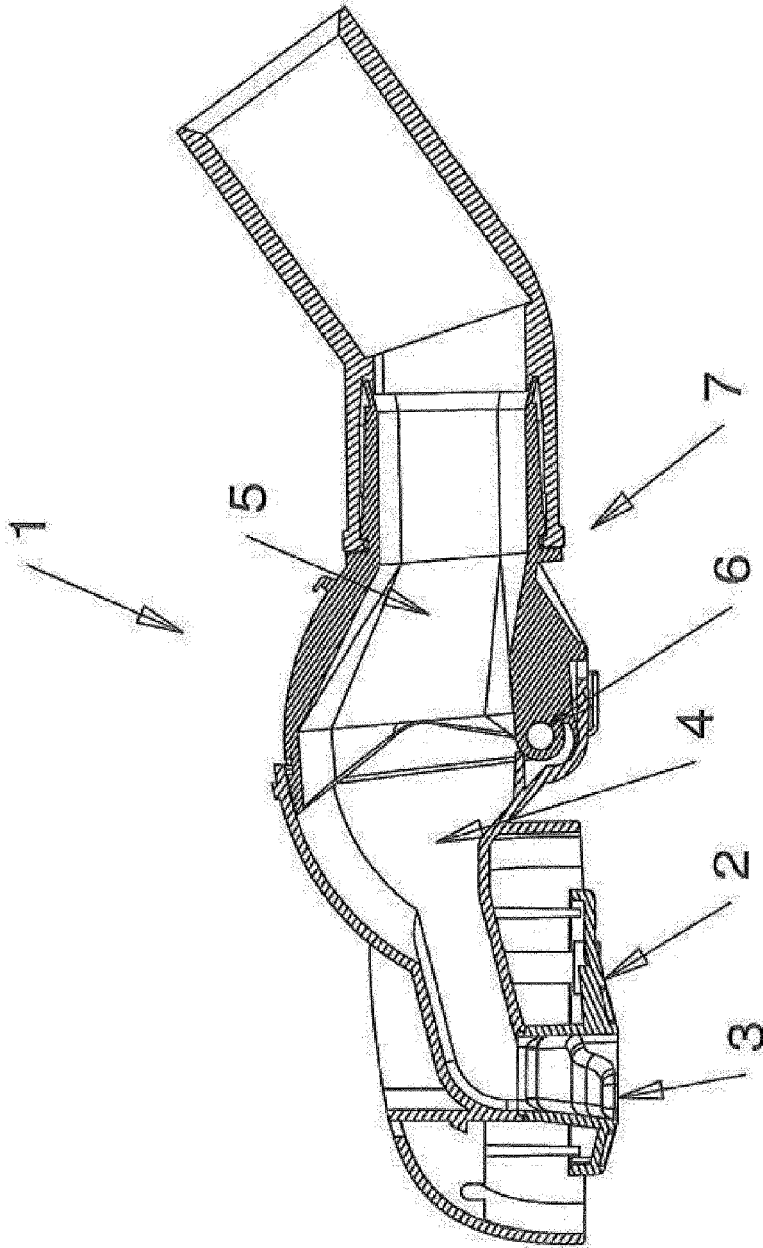

Fig. 1

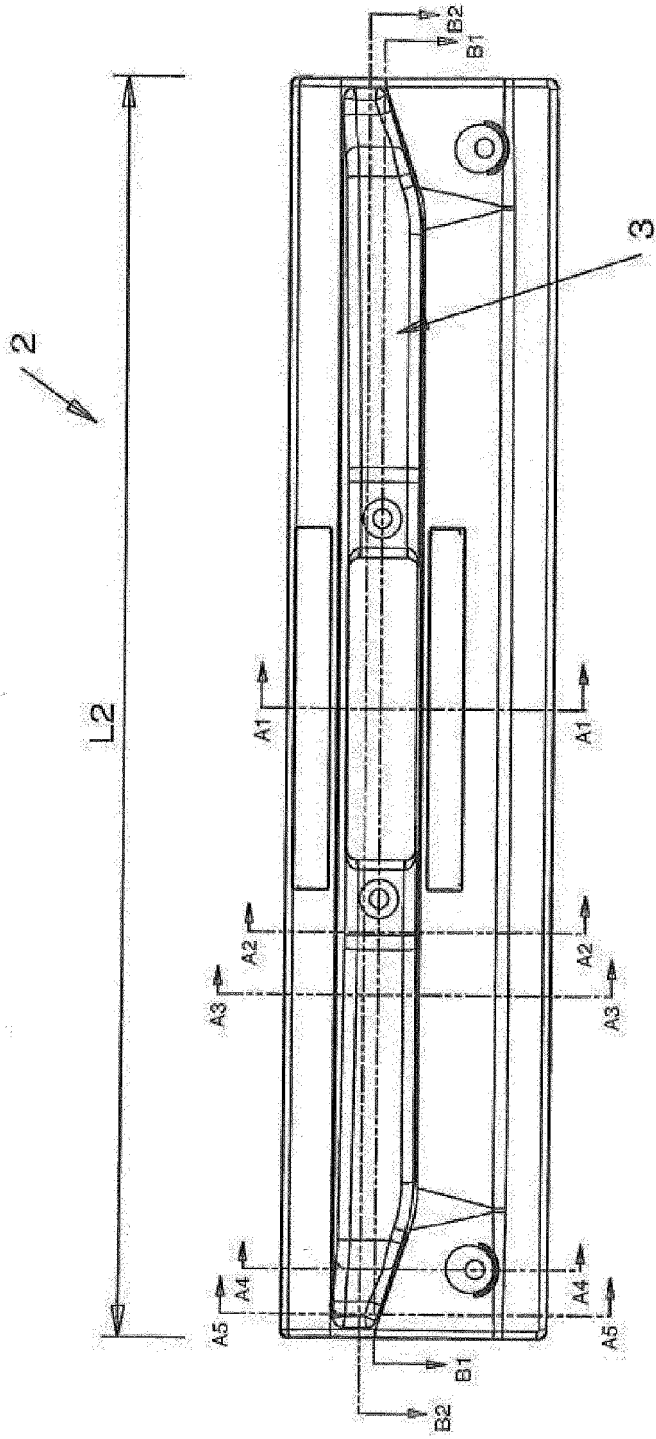

Fig. 2a

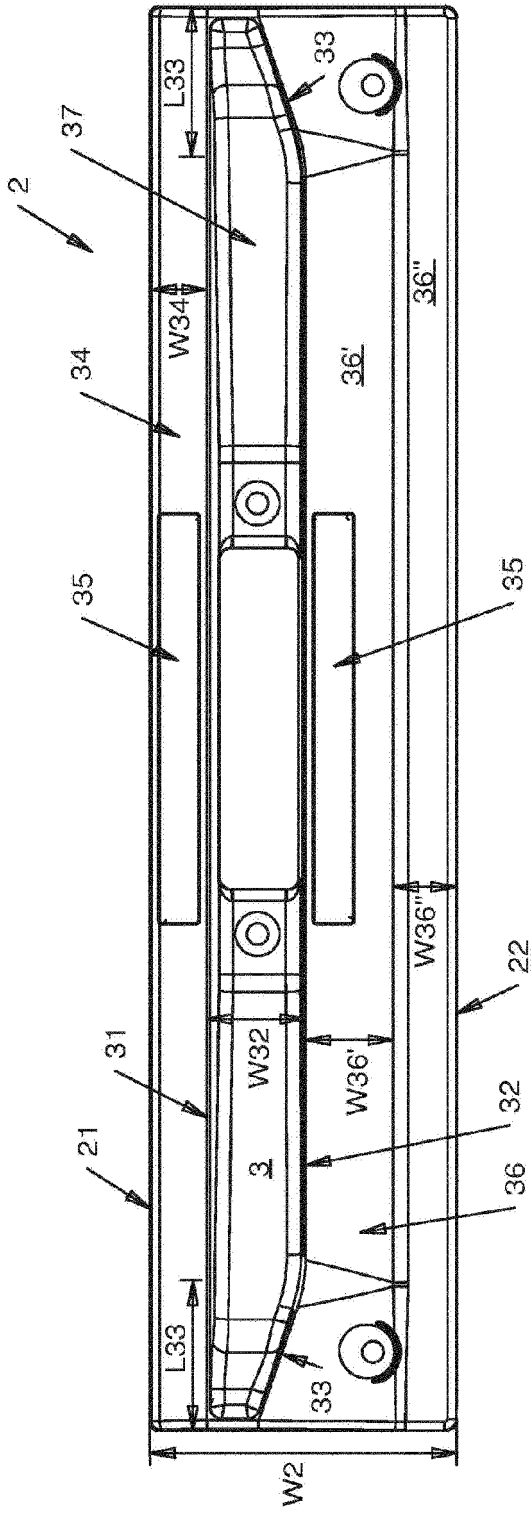

Fig. 2b

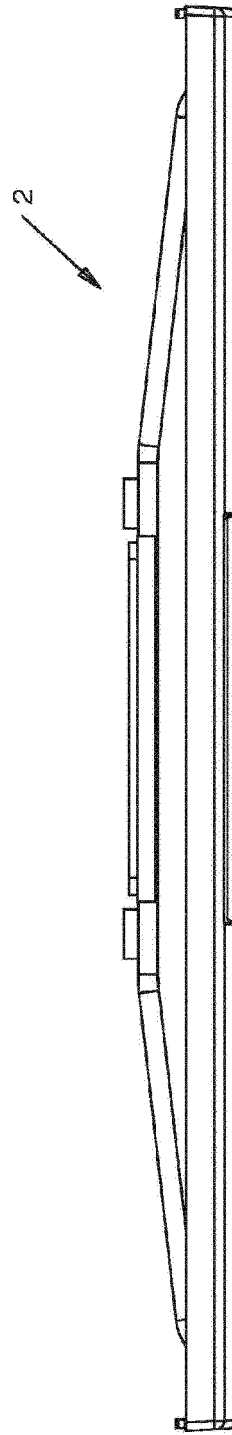
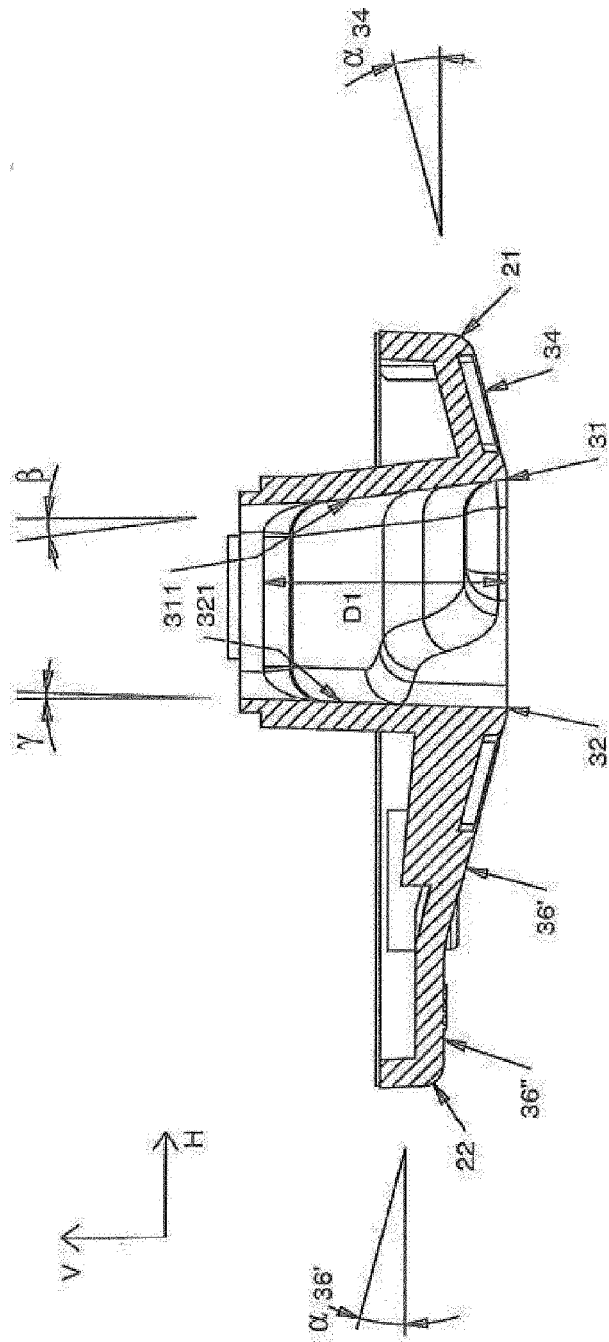

Fig. 3



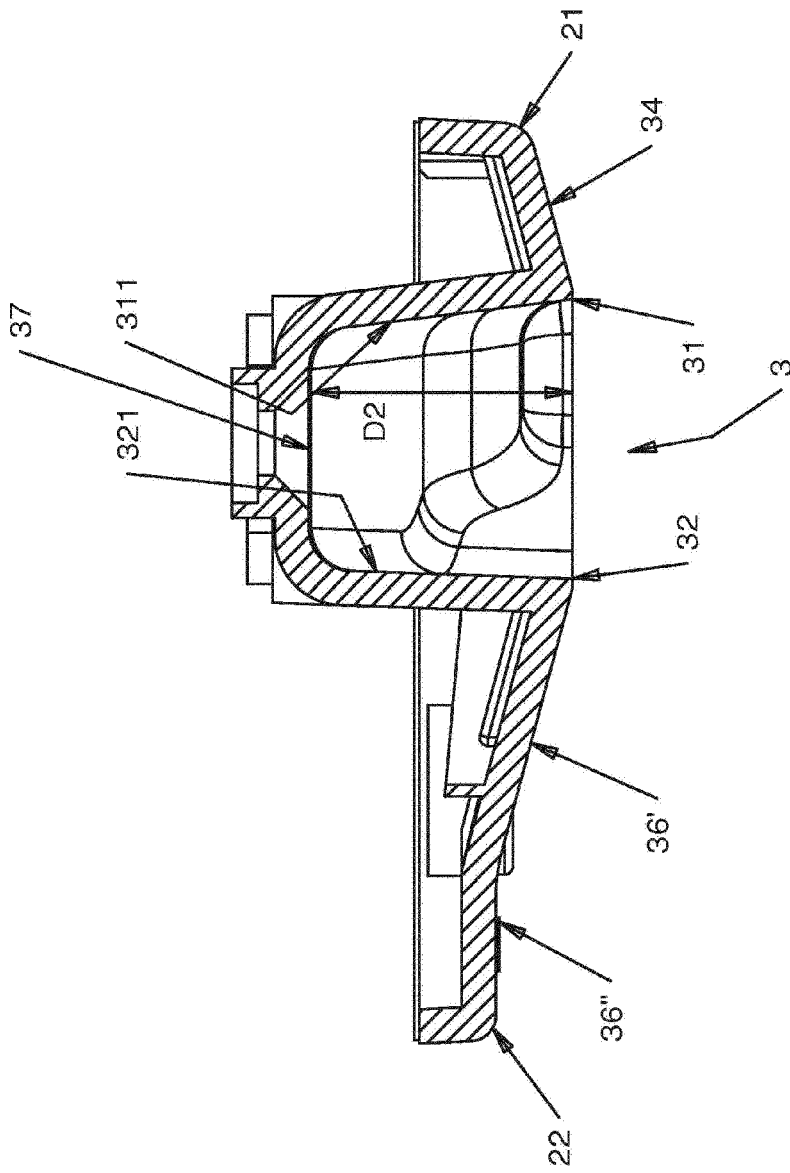

Fig. 4A2

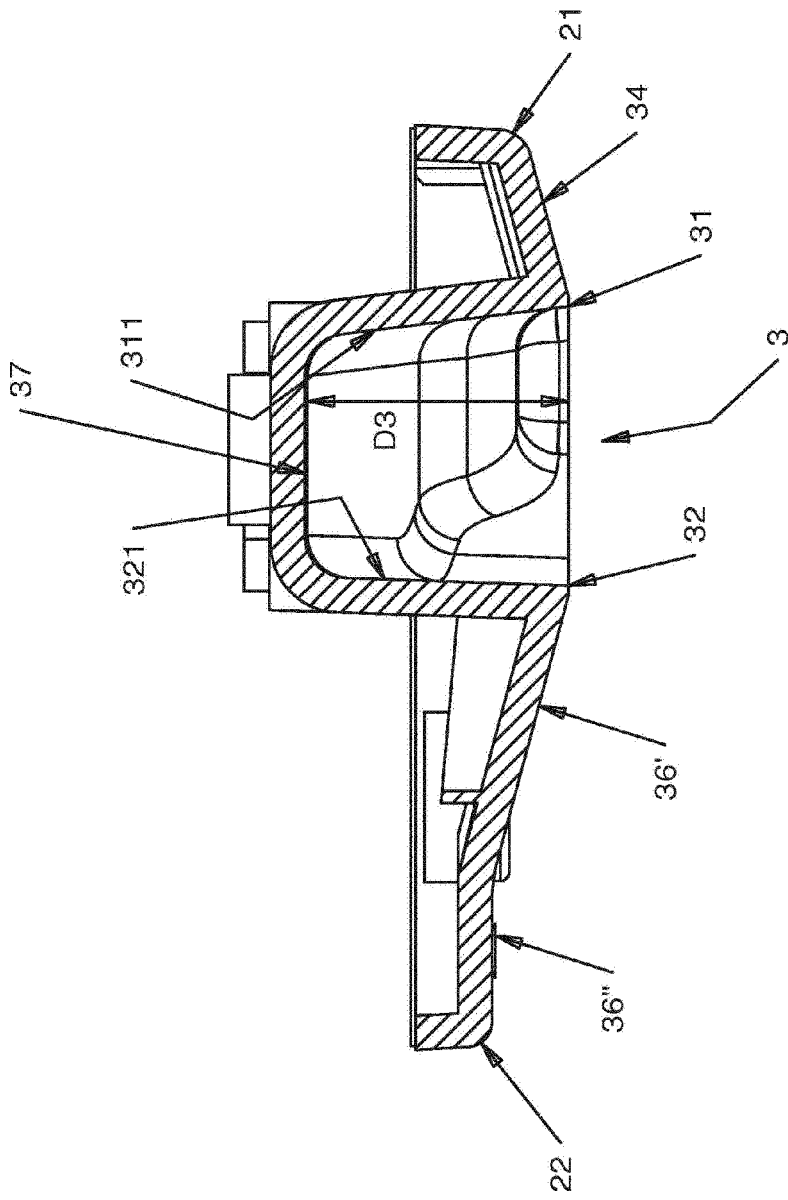

Fig. 4A3

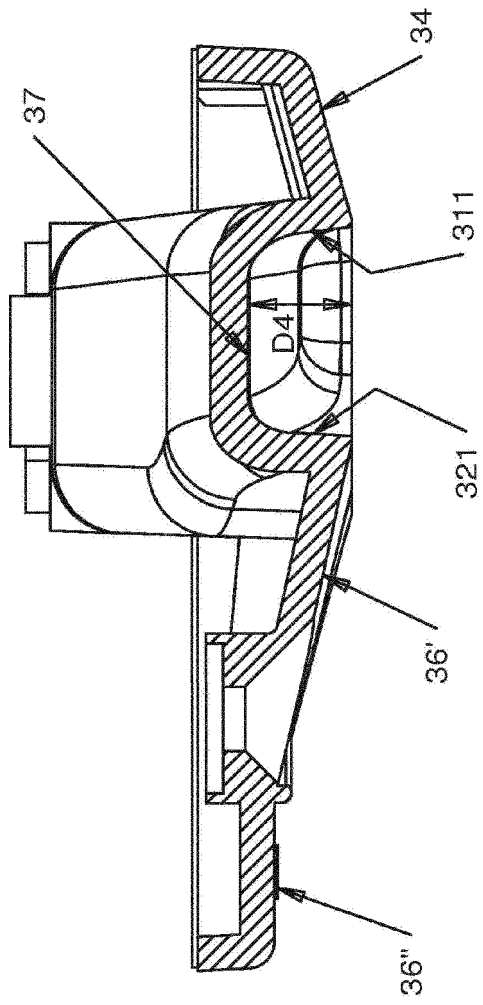

Fig. 4A4

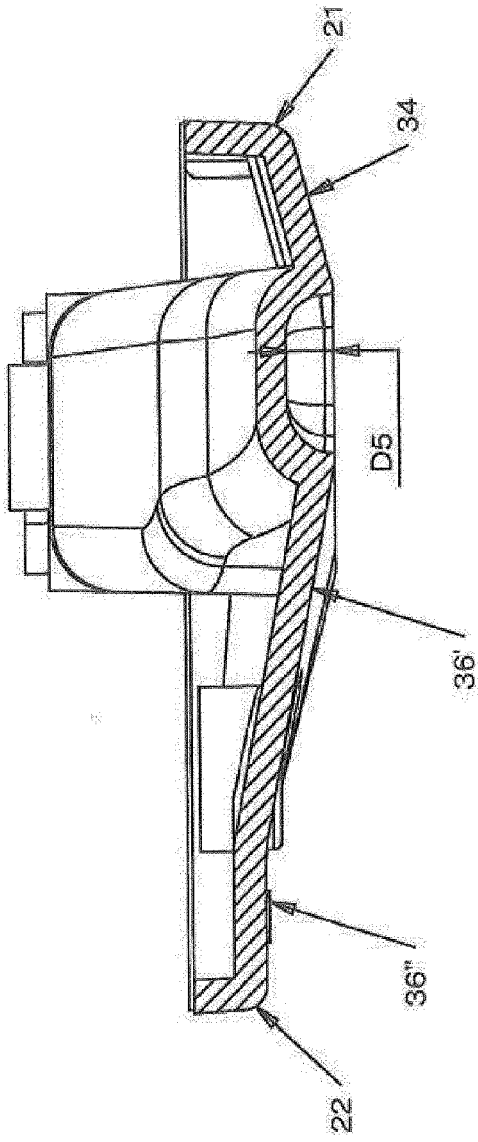

Fig. 4A5

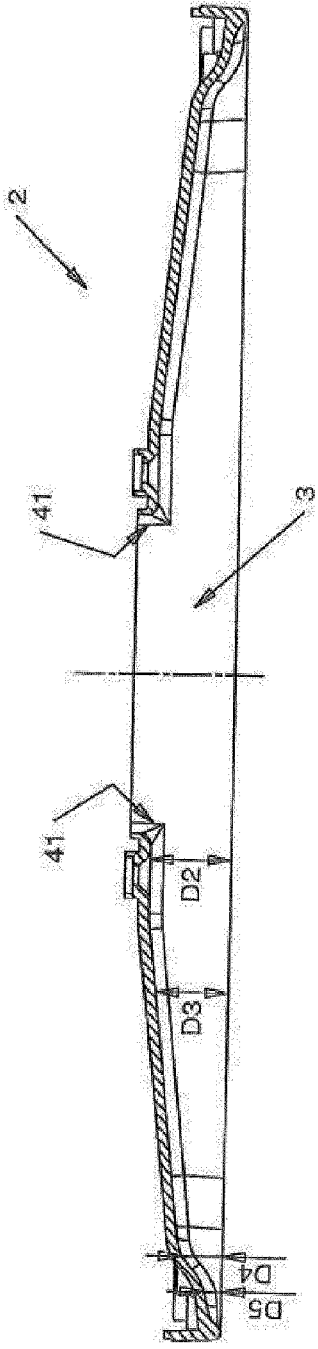

Fig. 5B1

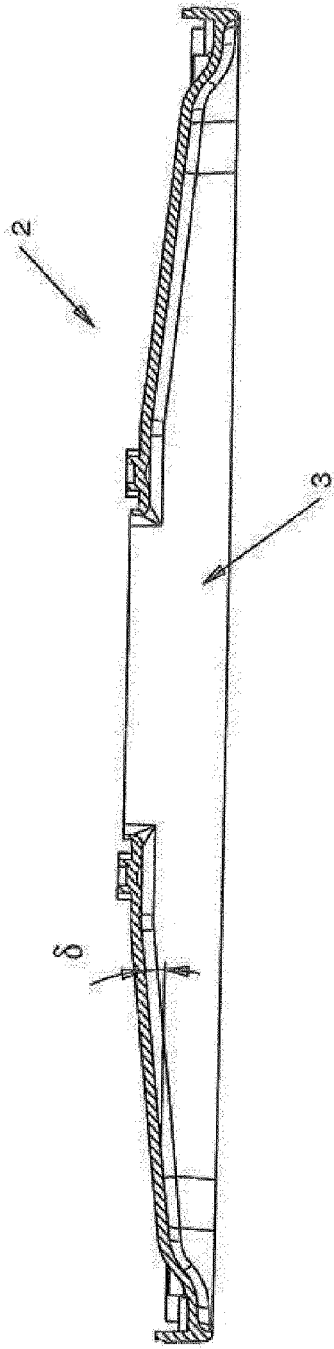

Fig. 5B2