



(12) **EUROPEAN PATENT APPLICATION**

(43) Date of publication:  
**02.12.2009 Bulletin 2009/49**

(51) Int Cl.:  
**B66C 19/00 (2006.01)**

(21) Application number: **09161063.4**

(22) Date of filing: **26.05.2009**

(84) Designated Contracting States:  
**AT BE BG CH CY CZ DE DK EE ES FI FR GB GR HR HU IE IS IT LI LT LU LV MC MK MT NL NO PL PT RO SE SI SK TR**

(72) Inventor: **Nurmi, Jorma**  
**33400, Tampere (FI)**

(30) Priority: **30.05.2008 FI 20085519**

(74) Representative: **Salonen, Esko Tapani**  
**Forssén & Salomaa Oy**  
**Lautatarhankatu 8 B**  
**00580 Helsinki (FI)**

(71) Applicant: **Kalmar Industries OY AB**  
**33900 Tampere (FI)**

(54) **Straddle carrier**

(57) The invention concerns a straddle carrier, which comprises a portal body (11), to which belong essentially vertical supporting pillars (13a, 13b) and an upper body (15) connecting them at the top, and on each side of the straddle carrier (10) at the lower end of the supporting pillars (13a, 13b) there are wheels (12) carrying the portal body (11). In between the supporting pillars (13a, 13b) under the upper body (15) necessary means are arranged for gripping the container load, and resting on the upper body (15) necessary hoisting devices are mounted for hoisting and supporting the container load. The means for gripping the container load comprise two container spreaders (16a, 16b), which are arranged in parallel in relation to the straddle carrier's (10) driving direction and which both are equipped each with its own hoisting beam structure (20a, 20b). The hoisting devices for hoisting and supporting the container load comprise an own separate hoisting mechanism arranged for each container spreader (16a, 16b). Each hoisting mechanism is connected separately through hoisting ropes (28a, 28b) to a corresponding hoisting beam structure (20a, 20b) for handling parallel container loads independently of each other.

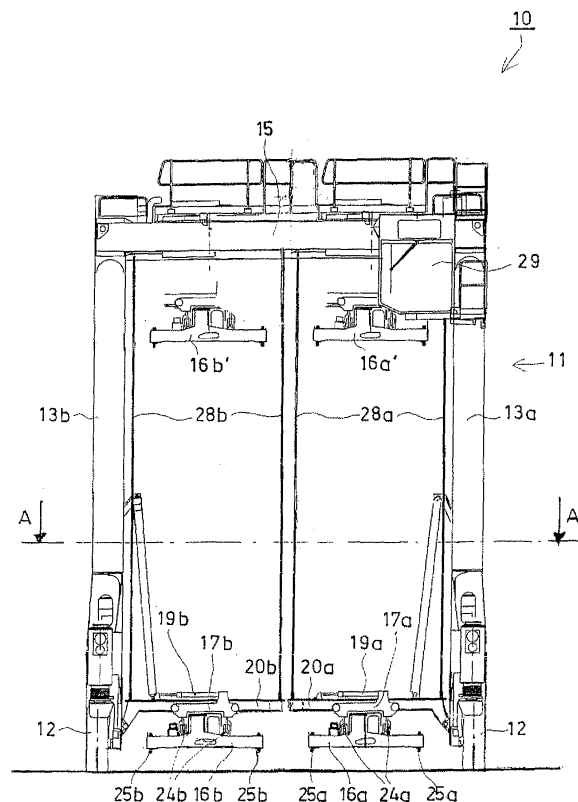

FIG. 2

## Description

**[0001]** The invention is related to the handling of containers in ports and terminals, especially with the aid of a so-called straddle carrier system. In greater detail, the invention concerns a straddle carrier, which comprises a portal body comprising essentially vertical supporting pillars and an upper body connecting them at the top, and on each side of the straddle carrier at the bottom end of the supporting pillars there are wheels carrying the portal body, whereby in between the supporting pillars below the upper body there are provided the necessary means for taking hold of the container load, and carried by the upper body there are mounted the necessary hoisting devices for hoisting and supporting the container load.

**[0002]** The invention thus is to do with the moving and transporting of freight with the aid of containers. The freight goods are transported conveniently in containers from the dispatcher/manufacturer of the goods directly to the buyer/recipient without any special intermediate stages. When transportation distances are long, the critical points of the transportation are located at those points where the manner of transporting the containers changes, such as in ports, where great quantities of containers are to be unloaded, placed in intermediate storage and reloaded for another mode of transportation. In ports the aim is to achieve as short loading/unloading times as possible, because it is expensive to have ships stay at the quayside and it will be even more expensive if the loading/unloading is delayed for some reason, thus causing the ship to be late in her scheduled line service. If a ship has to catch up for lost time on her line of service, she will have to use a higher and more uneconomical travelling speed, whereby her fuel consumption and costs will be higher than calculated. Thus, loading and unloading the ship must take place as quickly as possible and without any additional delays and disturbances.

**[0003]** For loading and unloading ships in ports they use a port crane, which lifts the containers either directly from trailers pulled by a vehicle or from under the crane, where they have been brought, for example, by a straddle carrier or by a transporting carrier, and it moves the containers into a ship or the other way round, that is, it moves the containers from the ship on to trailers or to a place under the crane for removal by a straddle carrier or by a transporting carrier. In the straddle carrier system, the straddle carrier or transporting carrier thus usually transports containers between the port crane and a storage area. Container cranes for their part are devices of a big size, and due to their big size it is a difficult and slow process to move them during these work rotations. When containers are moved directly on to a trailer or from a trailer, the port crane can handle only one container at a time. When using a straddle carrier system such solutions have already been developed, where the port crane is able to handle or hoist two containers at a time, so that the containers are located in parallel while being hoisted.

When a ship is unloaded, the port crane leaves the containers side by side under the crane waiting for transportation. Correspondingly, when loading, the containers must be left precisely in parallel under the crane, so that the port crane can pick them both up in one go. Until now it has not been possible with straddle carriers or, correspondingly, with transporting carriers to handle two parallel containers at the same time, for which reason it has not been possible to benefit fully from the port crane's possibility to handle two containers.

**[0004]** The straddle carrier should have a structure that is as favourable as possible for the development in the other environment and in equipment relating to the environment. In order to achieve this objective as well as other objectives emerging from the description of the invention, the invention is mainly **characterized in that** the means for gripping the container load comprise two container spreaders, which are arranged in parallel in relation to the straddle carrier's driving direction and each being equipped with its own hoisting beam structure, and in that the hoisting equipment for hoisting and supporting the container load comprises an own separate hoisting mechanism arranged for each container spreader, whereby each hoisting mechanism is through hoisting ropes or other such hoisting means connected separately to a corresponding hoisting beam structure for handling parallel container loads independently of each other.

**[0005]** The hoisting beam structures of parallel container spreaders are suitably supported each one separately in the horizontal direction on supporting pillars located in relation to the straddle carrier's driving direction on the corresponding container spreader's side of the straddle carrier. Each hoisting beam structure preferably comprises front and rear transverse beams and beam structures or other such connecting these in order to brace the hoisting beam structures. The hoisting beam structures are suitably supported on the straddle carrier's supporting pillars through slide shoe structures allowing movement in the vertical direction.

**[0006]** Side transfer carriages, from which the container spreaders are suspended, are mounted for the container spreaders to the transverse beams of the hoisting beam structures for movement along the transverse beams. The side transfer carriages are equipped with actuators, which are used for separately transferring the side transfer carriages and the container spreaders suspended from these in order to separate the containers from each other and, correspondingly, to move them closer towards each other.

**[0007]** The straddle carrier is a piling straddle carrier equipped with longitudinally controlled container spreaders for handling containers of different measurements. The straddle carrier's container spreaders may be twin-spreaders, whereby it is possible for the straddle carrier to handle four containers at the same time.

**[0008]** The invention provides significant advantages in comparison with the state of the art. Prominent among these advantages is, for example, the considerably better

efficiency, because in the straddle carrier system according to the invention it is possible to transport and correspondingly to pile on the storage area two containers in parallel at the same time. The achieved savings especially in energy and operator costs are significant. At the same time the storage density increases, because no driving lane need now be left for the straddle carrier's wheels in between every container row, but instead in between every second container row. Other advantages and characteristic features of the invention will emerge hereinafter from the following detailed description of the invention.

**[0009]** In the following, the invention will be described by way of example by referring to the figures in the appended drawing.

Figure 1 is an overall view from one side of the straddle carrier according to the invention.

Figure 2 is a corresponding view from the front of the straddle carrier shown in Figure 1.

Figure 3 is a schematic cross-sectional view along line A - A of Figure 2 showing the straddle carrier's hoisting beam structure.

**[0010]** In the figures of the drawing, the general reference number 10 indicates the straddle carrier. The straddle carrier 10 comprises a portal body 11, to which belong essentially vertical supporting pillars 13a, 13b, 14a, 14b and an upper body 15 connecting them at the top. On either side of straddle carrier 10 at the lower end of supporting pillars 13a, 13b, 14a, 14b there are wheels 12 supporting the portal body 11. The operator's cabin of straddle carrier 10 is indicated by reference number 29 in the figures. As illustrated in the figures of the drawing, especially in Figure 2, the basic features of straddle carrier 10 are preserved in the straddle carrier structure according to the invention, but the portal body 11 of the straddle carrier 10 according to the invention is made essentially wider than in state-of-the-art solutions in such a way that in between the body's supporting pillars 13a, 13b, 14a, 14b it has been possible to fit in two parallel container spreaders 16, 16a, 16b, whereby it is possible with the straddle carrier 10 to handle parallel containers at the same time. In Figure 2, the container spreaders are shown in the lower position with reference marks 16a, 16b and, correspondingly, in the upper position with reference marks 16a', 16b'.

**[0011]** In conventional straddle carriers, a hoisting mechanism is mounted to rest on the upper body of the carrier's portal body and it is connected, for example, by ropes to transverse hoisting beams, which are located in between the front supporting pillars and in between the rear supporting pillars and which carry the suspended container spreader. In the solution according to the invention, the hoisting beam structures are divided into two parts, so that they comprise a left-hand hoisting beam

structure 20a and correspondingly a right-hand hoisting beam structure 20b, that is, for each container spreader 16a, 16b there is its own hoisting beam structure. In the solution according to the invention, there is mounted to rest on the straddle carrier's 10 upper body 15 also for each hoisting beam structure 20a, 20b its own hoisting mechanism (not shown), whereby each hoisting beam structure 20a, 20b and the connected container spreaders 16a, 16b can be moved independently of each other in the height direction. Hereby, when parallel containers are handled, they need not be of the same height, and they need not even be located at the same height position, that is, in parallel container piles there may be, for example, four containers on top of each other in one pile, while in the other pile there may be, for example, two containers, and despite this there will be no problem with the picking up and leaving of containers.

**[0012]** Each hoisting beam structure 20a, 20b comprises front and rear transverse beams 21a, 21b, 22a, 22b and their connecting longitudinal beams 23a, 23b or other such beam structures for bracing the structure. Figure 3 also shows in dashed lines that in order to achieve additional rigidity there may also be second longitudinal beams 23a', 23b' arranged in the hoisting beam structures 20a, 20b. The hoisting beam structures 20a, 20b can also be braced in other ways, for example, with the aid of diagonal beams or other such, so the structure is not limited only to the one shown in the figures. For horizontal supporting of the hoisting beam structures there are slide shoe structures 27a, 27b or other such guides arranged in between the hoisting beam structures 20a, 20b and the supporting pillars 13a, 13b, 14a, 14b, whereby the hoisting beam structures will get the required guidance from said supporting pillars 13a, 13b, 14a, 14b. Slide shoe structures 27a, 27b or other such structures are used in connection both with the front 13a, 13b and rear 14a, 14b supporting pillars. Each hoisting beam structure 20a, 20b is connected by its own hoisting ropes 28a, 28b to its own separate hoisting mechanisms (not shown), which are located in the upper body 15 and with the aid of which the hoisting movement is implemented. The hoisting mechanisms are not described in greater detail in this connection and they may be, for example, of such a structure and operation, which are described in the applicant's earlier FI Patent 107142.

**[0013]** To each hoisting beam structure 20a, 20b side transfer carriages 17a, 17b, 18a, 18b are mounted, so that there are two of these both in the left-hand and in the right-hand hoisting beam structure. The side transfer carriages 17a, 17b, 18a, 18b are mounted to rest on the hoisting beam structures' front 21a, 21b and rear 22a, 22b transverse beams, so that they can be moved in the straddle carrier's 10 transverse direction. The side transfer carriages 17a, 17b, 18a, 18b are equipped with actuators, for example, with the hydraulic cylinders 19a, 19b shown in Figure 2 or with corresponding equipment. Actuators of other types may also be used, and an electric drive (for example, a combination of an electric motor

and a chain transmission) can be mentioned as a possible solution. The container spreaders 16a, 16b are suspended from the side transfer carriages 17a, 18a, 17b, 18b with the aid of suitable suspending means 24a, 24b, for example, with the aid of chains and suitable guides or other such. With the aid of side transfer carriages 17a, 17b, 18a, 18b and their actuators 19a, 19b it is possible to separate adjacent containers from each other when required.

**[0014]** In the figures, reference marks 25, 26, 25a, 25b indicate the container spreaders' 16, 16a, 16b hoisting shanks, with which the containers are gripped at the upper corners of the containers. The container spreaders 16, 16a, 16b themselves are longitudinally controlled in such a way that they can be used for handling at least the 20' - 45' containers in use today. Containers located in parallel need not even be of equal length, but the straddle carrier 10 can be used for parallel handling of even 20' and 45' containers at the same time. Although it is not shown in the figures, as container spreaders 16, 16a, 16b it is also possible to use so-called twin-spreaders, which are equipped with middle shanks in addition to the hoisting shanks located at the ends. With one such twin-spreader it is possible at the same time to lift and move two 20' containers located one behind the other, whereby the straddle carrier 10 according to the invention when equipped with such container spreaders is able to handle four 20' containers in one go.

**[0015]** In the foregoing, the invention was described by way of example with reference to the figures in the appended drawing. However, the invention is not limited to concern only the examples shown in the figures, but different embodiments of the invention may vary within the scope of the inventive idea defined in the appended claims.

## Claims

1. Straddle carrier, which comprises a portal body (11), to which belong essentially vertical supporting pillars (13a, 13b, 14a, 14b) and an upper body (15) connecting them at the top, and on each side of the straddle carrier (10) at the lower end of the supporting pillars (13a, 13b, 14a, 14b) there are wheels (12) supporting the portal body (11), whereby in between the supporting pillars (13a, 13b, 14a, 14b) under the upper body (15) necessary means are arranged for gripping the container load, and resting on the upper body (15) necessary hoisting devices are mounted for hoisting and supporting the container load, **characterized in that** the means for gripping the container load comprise two container spreaders (16a, 16b), which are arranged in parallel in relation to the straddle carrier's (10) driving direction, each one equipped with its own hoisting beam structure (20a, 20b), and that the hoisting devices for lifting and supporting the container load comprise an own separate hoisting mechanism arranged for each container spreader (16a, 16b), whereby each hoisting mechanism is separately connected through hoisting ropes (28a, 28b) or other such hoisting means to a corresponding hoisting beam structure (20a, 20b) in order to handle parallel container loads independently of each other.
2. Straddle carrier according to claim 1, **characterized in that** the hoisting beam structures (20a, 20b) of parallel container spreaders (16a, 16b) are each separately supported in the horizontal direction on supporting pillars (13a, 14a, 13b, 14b) located in relation to the straddle carrier's (10) driving direction on the corresponding container spreader's (16a, 16b) side of the straddle carrier (10).
3. Straddle carrier according to claim 1 or 2, **characterized in that** each hoisting beam structure (20a, 20b) comprises front and rear transverse beams (21a, 21b, 22a, 22b) and their connecting beam structures (23a, 23b, 23a', 23b') or other such for bracing the hoisting beam structures (20a, 20b).
4. Straddle carrier according to claim 3, **characterized in that** in the transverse beams (21a, 21b, 22a, 22b) of the hoisting beam structures (20) there are mounted side transfer carriages (17a, 17b) for the container spreaders (16a, 16b), which carriages can be moved along the transverse beams and from which carriages the container spreaders (16a, 16b) are suspended.
5. Straddle carrier according to claim 4, **characterized in that** the side transfer carriages (17a, 17b) are equipped with actuators (19a, 19b), by which the side transfer carriages (17a, 17b) and their suspended container spreaders (16a, 16b) can be transferred separately in order to separate the containers from each other and, correspondingly, to move them closer towards each other.
6. Straddle carrier according to some preceding claim, **characterized in that** the hoisting beam structures (20a, 20b) are supported on the straddle carrier's (10) supporting pillars (13a, 14a, 13b, 14b) through slide shoe structures (27a, 27b) allowing movement in the vertical direction.
7. Straddle carrier according to some preceding claim, **characterized in that** the straddle carrier (10) is a piling straddle carrier equipped with longitudinally controlled container spreaders (16a, 16b) for handling containers of different measurements.
8. Straddle carrier according to some preceding claim, **characterized in that** the straddle carrier's (10) container spreaders are twin-spreaders (16a, 16b),

whereby it is possible with the straddle carrier to handle four containers at the same time.

5

10

15

20

25

30

35

40

45

50

55

5

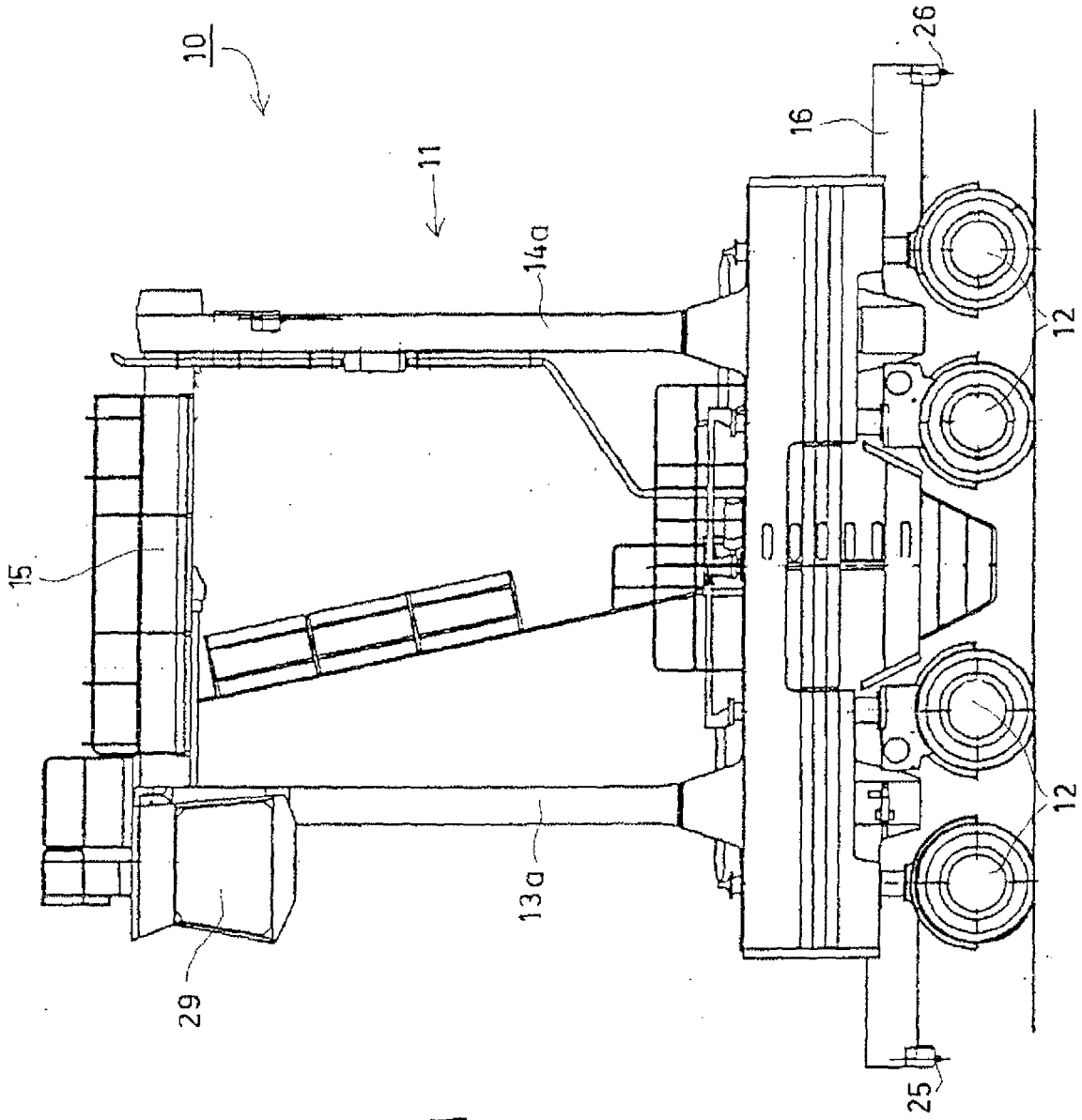

FIG. 1

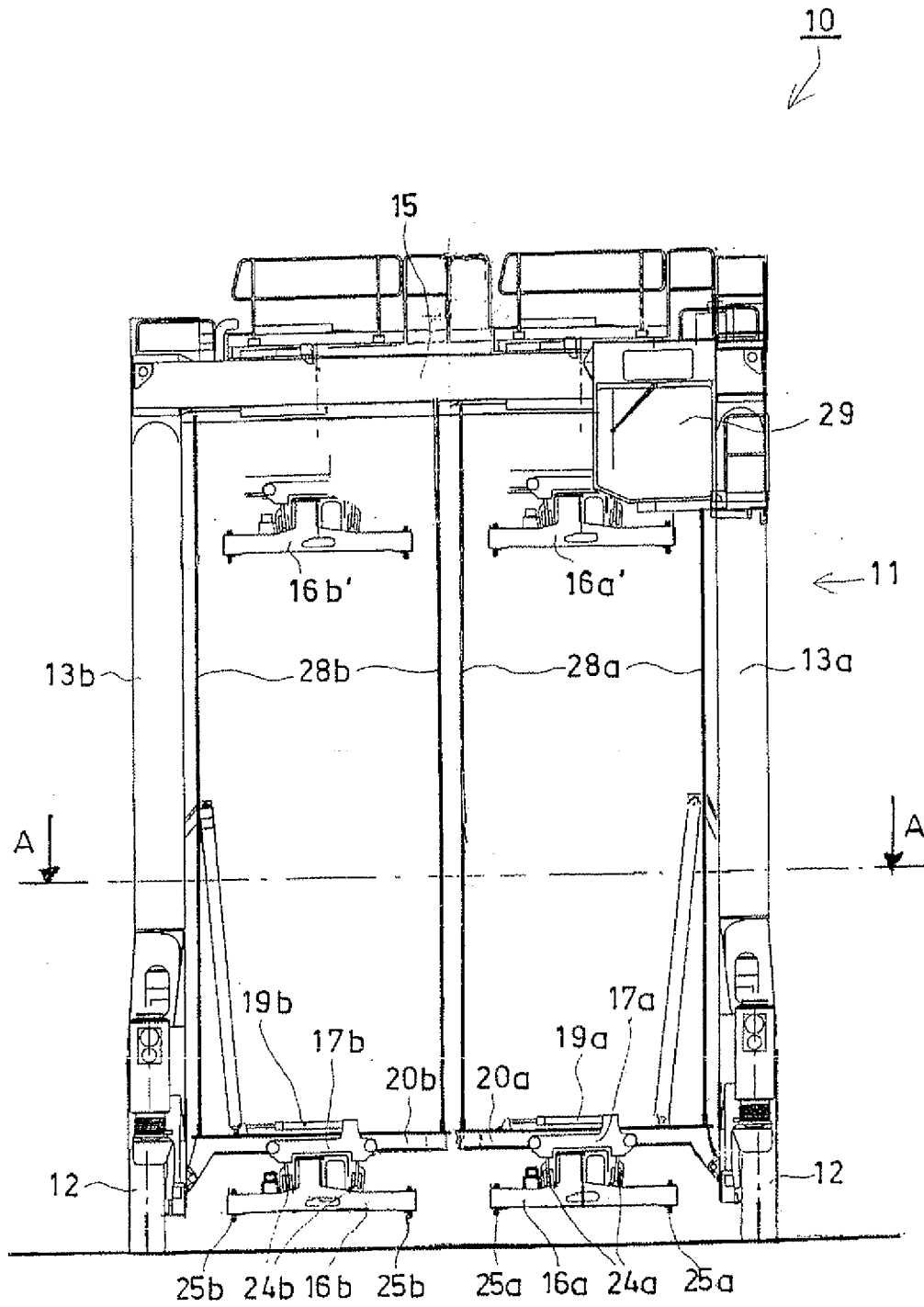

FIG. 2

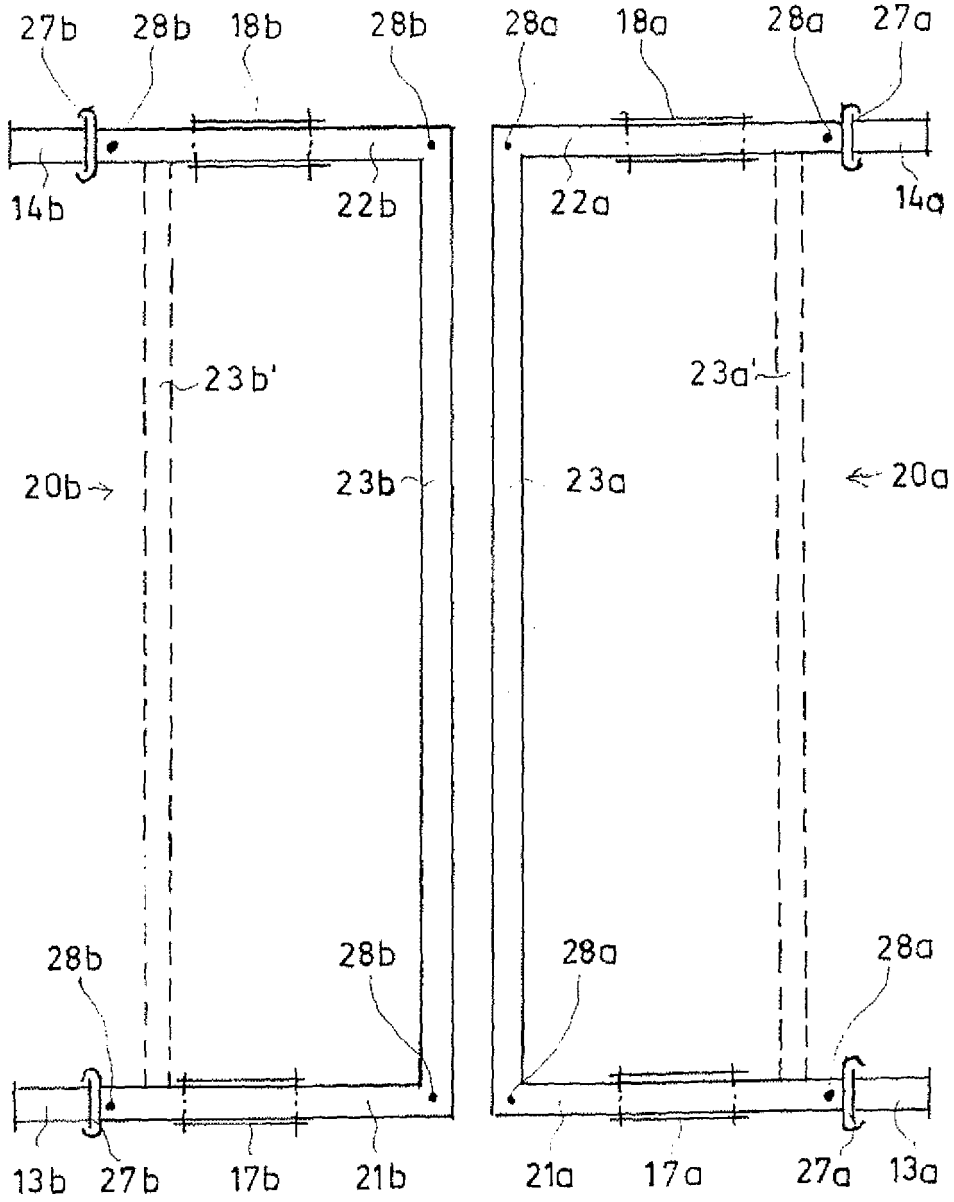

FIG. 3





EUROPEAN SEARCH REPORT

Application Number  
EP 09 16 1063

| DOCUMENTS CONSIDERED TO BE RELEVANT  |  |   |   |
|--|--|---|---|
| Category   | Citation of document with indication, where appropriate, of relevant passages  | Relevant to claim   | CLASSIFICATION OF THE APPLICATION (IPC) |
| A  | DE 103 55 946 A1 (NOELL MOBILE SYSTEMS & CRANES [DE]) 7 July 2005 (2005-07-07)<br>* paragraph [0016]; figure 1 *<br>-----                                    | 1   | INV.<br>B66C19/00                       |
| P,A  | EP 2 048 106 A (NOELL MOBILE SYSTEMS GMBH [DE]) 15 April 2009 (2009-04-15)<br>* paragraphs [0009], [0016], [0017] *<br>-----                                 | 1   |   |
| A  | WO 2005/090223 A (NSL ENGINEERING PTE LTD [SG]; MILLS ROBERT ARTHUR [GB]; TANG JINBEI [S]) 29 September 2005 (2005-09-29)<br>* abstract; figure 5 *<br>----- | 1   |   |
| A  | EP 1 857 401 A (BROMMA CONQUIP AB [SE]) 21 November 2007 (2007-11-21)<br>* paragraphs [0014], [0015]; figure 1 *<br>-----                                    | 1   |   |
|  |  |   | TECHNICAL FIELDS SEARCHED (IPC)         |
|  |  |   | B66C                                    |
| The present search report has been drawn up for all claims                       |  |   |   |
| Place of search  |  | Date of completion of the search  | Examiner                                |
| The Hague  |  | 25 August 2009  | Serôdio, Renato                         |
| CATEGORY OF CITED DOCUMENTS  |  |   |   |
| X : particularly relevant if taken alone   |  | T : theory or principle underlying the invention                        |   |
| Y : particularly relevant if combined with another document of the same category |  | E : earlier patent document, but published on, or after the filing date |   |
| A : technological background   |  | D : document cited in the application                                   |   |
| O : non-written disclosure   |  | L : document cited for other reasons                                    |   |
| P : intermediate document  |  | & : member of the same patent family, corresponding document            |   |

2  
EPO FORM 1503 03.02 (P/MC01)

ANNEX TO THE EUROPEAN SEARCH REPORT  
ON EUROPEAN PATENT APPLICATION NO.

EP 09 16 1063

This annex lists the patent family members relating to the patent documents cited in the above-mentioned European search report. The members are as contained in the European Patent Office EDP file on  
The European Patent Office is in no way liable for these particulars which are merely given for the purpose of information.

25-08-2009

| Patent document cited in search report | Publication date | Patent family member(s) | Publication date   |            |
|--|------------------|-------------------------|--------------------|------------|
| DE 10355946                            | A1               | 07-07-2005              | FI 20041532 A      | 30-05-2005 |
|  |                  |                         | SE 529213 C2       | 29-05-2007 |
|  |                  |                         | SE 0402869 A       | 30-05-2005 |
| -----                                  |                  |                         |                    |            |
| EP 2048106                             | A                | 15-04-2009              | CN 101428745 A     | 13-05-2009 |
|  |                  |                         | DE 102007049012 A1 | 16-04-2009 |
|  |                  |                         | KR 20090037360 A   | 15-04-2009 |
|  |                  |                         | US 2009097935 A1   | 16-04-2009 |
| -----                                  |                  |                         |                    |            |
| WO 2005090223                          | A                | 29-09-2005              | CA 2560974 A1      | 29-09-2005 |
|  |                  |                         | CN 1950289 A       | 18-04-2007 |
|  |                  |                         | EP 1730069 A1      | 13-12-2006 |
|  |                  |                         | JP 2007530386 T    | 01-11-2007 |
|  |                  |                         | KR 20060130673 A   | 19-12-2006 |
|  |                  |                         | US 2007296228 A1   | 27-12-2007 |
| -----                                  |                  |                         |                    |            |
| EP 1857401                             | A                | 21-11-2007              | NONE               |            |
| -----                                  |                  |                         |                    |            |

**REFERENCES CITED IN THE DESCRIPTION**

*This list of references cited by the applicant is for the reader's convenience only. It does not form part of the European patent document. Even though great care has been taken in compiling the references, errors or omissions cannot be excluded and the EPO disclaims all liability in this regard.*

**Patent documents cited in the description**

- FI 107142 [0012]