

Sept. 24, 1940.

O. H. LUDEMAN

2,215,819

BOILER FEED SYSTEM

Filed Jan. 10, 1939

3 Sheets-Sheet 1

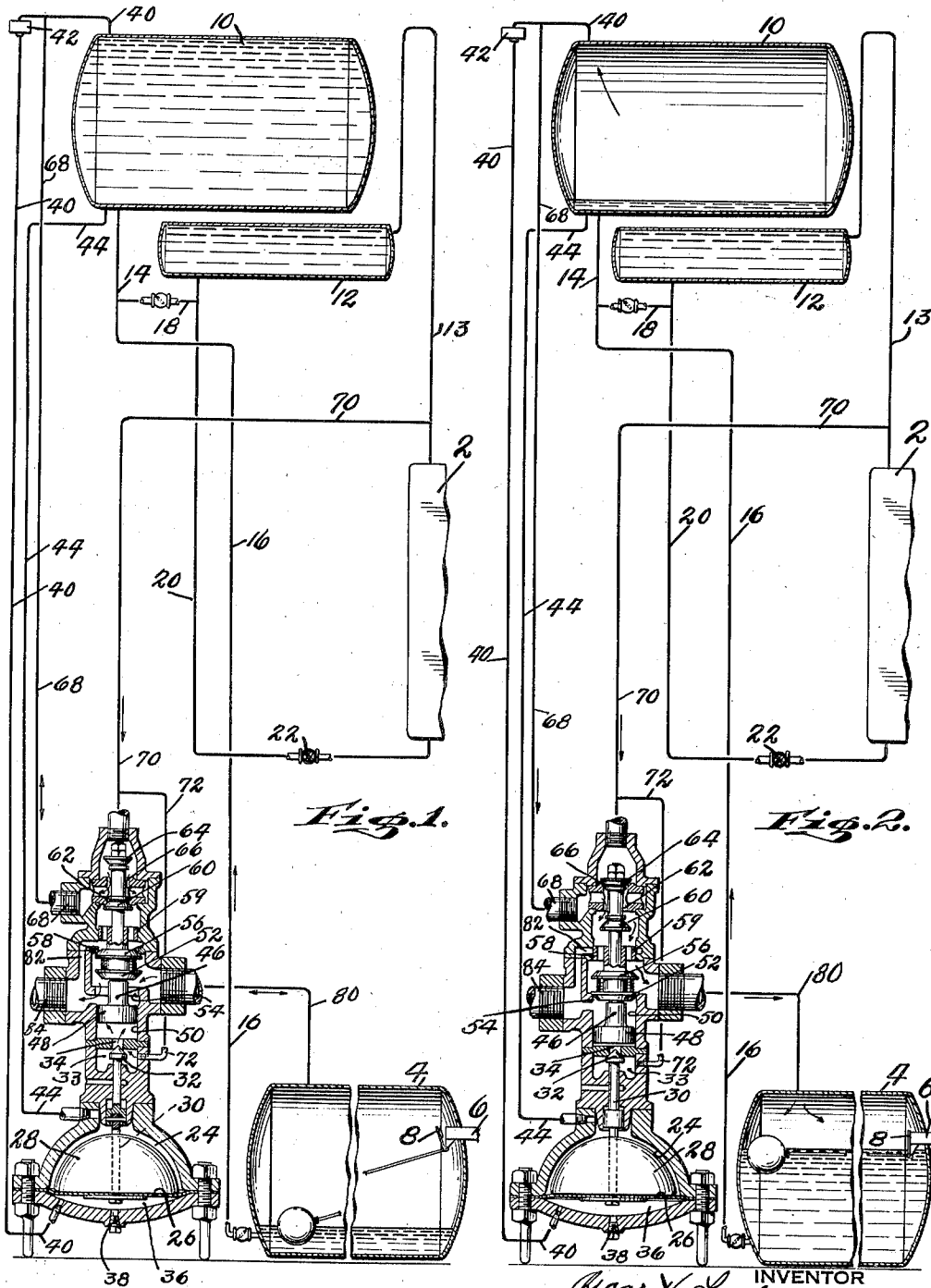

Fig. 1.

Fig. 2.

Oscar X. Ludeman  
INVENTOR

BY  
Little, Reshell and Montgomery,  
ATTORNEYS.



Sept. 24, 1940.

O. H. LUDEMAN

2,215,819

BOILER FEED SYSTEM

Filed Jan. 10, 1939

3 Sheets-Sheet 3

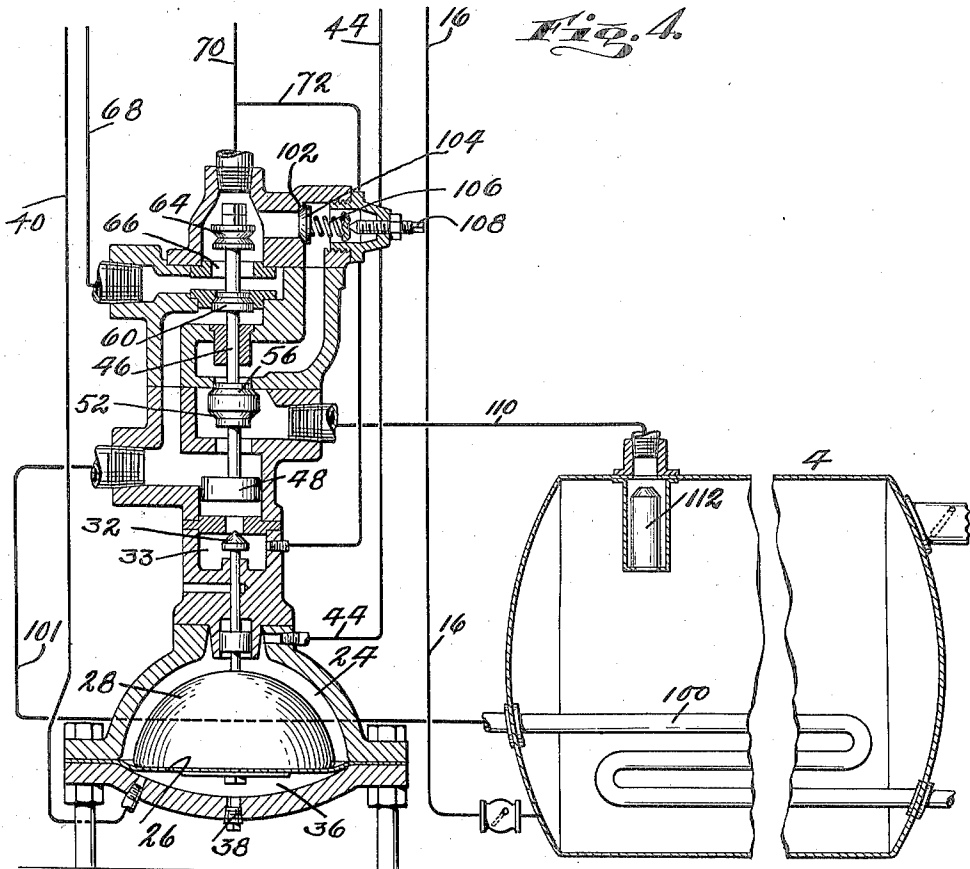

INVENTOR  
*Oscar H. Ludeman.*  
BY  
*Kiddle, Rehell and Montgomery.*  
ATTORNEYS

# UNITED STATES PATENT OFFICE

2,215,819

## BOILER FEED SYSTEM

Oscar H. Ludeman, Rye, N. Y.

Application January 10, 1939, Serial No. 250,175

10 Claims. (Cl. 122—456)

This invention relates to boiler feed systems and has for its primary object the provision of a feed system whereby water is fed to a boiler automatically and as required without the necessity of a pump.

Three embodiments of my invention have been shown in the accompanying drawings:

Fig. 1 illustrates one embodiment of my invention somewhat diagrammatically, the control mechanism, however, being shown in sectional elevation;

Fig. 2 is a view similar to Fig. 1 with the various components of the control mechanism in different positions;

Fig. 3 is a view similar to Fig. 1 showing another embodiment of my invention; and

Fig. 4 is a view somewhat similar to Fig. 1 showing still another embodiment of the invention.

Referring to the drawings in detail and first of all to the embodiment illustrated in Figs. 1 and 2:

2 designates the boiler to be fed and 4 a water supply tank, the water supply connection 6 to this tank, and leading from any suitable water source, is shown controlled by float valve 8.

Above the level of the boiler 2 is a tank 10, hereinafter to be referred to as a gravity tank, and just below this gravity tank, but also above the level of the boiler, is a tank 12, to be referred to hereinafter as an intermediate tank. The tanks 10 and 12 instead of being two separate units as illustrated may be embodied in a single structure.

The capacity of the water supply tank 4 is considerably greater than that of the gravity tank 10 and it will always fill at a greater rate than the gravity tank will empty, so that a supply of water is available at all times for the gravity tank.

The gravity tank 10 is connected to water supply tank 4 by lines 14 and 16, while the gravity tank and the intermediate tank are connected to the boiler 2 by lines 14, 18 and 20. The latter is equipped with a control valve 22 or other suitable feed water control.

To the left of the water supply tank 4 I have illustrated the control system now to be described.

The lower part or base of this equipment comprises a chamber 24 above a transverse diaphragm 26. The diaphragm is weighted by a weight 28. This chamber is connected to or near the bottom of the gravity tank by line 44.

Attached to the diaphragm 26 is the vertically

extending stem 30 of a steam valve 32 controlling port 34.

Below the diaphragm 26 is a chamber 36, provided with drain plug 38 and connected to the upper side of the gravity tank 10 by line 40 which is always full of water. An expansion reservoir or equalizer 42 is provided at the upper end of the line 40 for the purpose of minimizing the rise and fall of water in this line when the diaphragm 26 is deflected.

Above the steam valve 32 the control mechanism is equipped with a vertically extending stem 46. At the lower end of this stem is a piston 48 having a short vertical movement in cylinder 50 in which it loosely fits. Above the piston is a valve 52 on the stem 46 and controlling an annular port 54 surrounding the stem 46. Immediately above the valve 52 and loose on the stem 46 is a spring loaded valve 56, seating oppositely to valve 52 to control annular port 58. Attached to this valve is a ported sleeve 59 riding on the stem 46 with the valve.

Above the ported sleeve 59 and fast on the stem 46 is an exhaust valve 60 controlling an annular port 62, while secured to the stem 46 above the exhaust valve is steam supply valve 64 controlling annular port 66.

A line 68 leads from the top of the tank 10 to the upper part of the control mechanism just above the port 62.

Steam line 70 leads from the boiler 2 or the boiler header to the top of the control mechanism, and connection 72 leads from this line to the chamber 33 which surrounds the steam valve 32, so that there is always pressure in this chamber.

It will be seen that in Fig. 1 both tanks 10 and 12 are full of water, and under these conditions the control mechanism parts are in the positions shown in the same figure.

With the gravity tank 10 full of water, the lines 40 and 44 are filled to approximately the same height so that the hydrostatic loads on the upper and lower sides of the diaphragm 26 are in balance, hence the weight 28 will flex the diaphragm downwardly to hold the steam valve 32 off its seat. The unseating of this valve admits live steam from the boiler 2 to the piston 48 forcing the latter upwardly in its cylinder to unseat the valve 52, seat the exhaust valve 60 and unseat the steam valve 64. Under these conditions high pressure steam is admitted by way of lines 70 and 68 to the top of the gravity tank, thereby permitting water to flow from this tank to the boiler 2 by way of feed lines 14 and 20 as fast as the valve 22 or other feed water control

will permit. Inasmuch as the intermediate tank 12 is under constant boiler pressure by way of line 13 it will be kept full of water while the gravity tank is feeding to the boiler.

5 During the emptying of the gravity tank 10 live steam is being admitted to the tank. When the gravity tank has emptied sufficiently so that the hydrostatic load on the lower side of the diaphragm overcomes the hydrostatic load on the upper side of the diaphragm plus the load imposed by the weight 28 the diaphragm will move upwardly from the position shown in Fig. 1 to the position shown in Fig. 2, thereby closing or seating the steam valve 32, so that steam is no longer admitted to the cylinder 50 below the piston 48, and the latter which is a loose fit in its cylinder will move downwardly because of the live steam pressure on valve 64 as seen in Fig. 2. This will seat the valve 52 and the live steam valve 64 and at the same time unseat exhaust valve 60.

The steam in the gravity tank 10 will now exhaust through line 68 past the open exhaust valve 60, through the ported sleeve 59 and unseat the spring loaded check valve 53 to establish communication with the space above the water in the supply tank 4, the steam exhausting through the ports in the sleeve 59 past the valve 56 and by way of pipe line 80 to the space above the water in the supply tank. The sleeve 59 being attached to the check valve 53 moves downwardly as the valve is unseated to close port 82 leading to exhaust outlet 84. When the steam pressure in the tank 10 equalizes the pressure above the water in the supply tank 4 then the check valve 56 will close again under the action of its spring, the sleeve 59 moving upwardly to uncover the passageway 82 to permit the remaining steam in tank 10 and line 68 to exhaust through exhaust outlet 84.

It will be appreciated that the gravity tank 10 will now be refilled from the supply tank 4 by expansion of the entrapped steam in the supply tank and when the gravity tank has refilled the parts will again take the position shown in Fig. 1 ready for a repetition of the operating cycle above described. It will be seen that in the movement of the parts from the position shown in Fig. 2 to the position shown in Fig. 1, the piston 48 moves upwardly unseating valve 52, permitting of free vent of steam, vapors or gases from tank 4 while this tank is refilling from water supply 6.

In the interim between the time that the gravity tank is emptied until it is again filled the boiler will be supplied with water from the intermediate tank 12, this tank being under constant boiler pressure, as above explained.

It will be seen from all of the foregoing that I have provided a pumpless boiler feed system wherein no pump is required and wherein the operation is full automatic.

In the embodiment of my invention as illustrated in Fig. 3 I have shown my invention applied to a closed heater system. The operation of this system is very similar to that already described. For clarity of description parts in Fig. 3 corresponding to those already described will be given the same reference characters.

70 Referring to Fig. 3, the boiler 2 in this embodiment of my invention is to be supplied with water from feed water heater 92. 10 designates a gravity tank and 12 an intermediate tank connected by lines 14 and 16 to the feed water heater 92, and by lines 14, 18 and 20 to the

boiler, the line 20 being equipped with control valve 22 or other feed water control.

The control apparatus in this embodiment of my invention is somewhat simplified. The lower part or base of this equipment comprises chamber 24 across which is a diaphragm 26 weighted by weight 28.

Attached to the diaphragm is the vertically extending stem 30 of a steam valve 32 controlling the port 34.

The chamber 36 below the diaphragm which is provided with a drain plug 38 is connected to the upper side of the gravity tank by line 40. An expansion reservoir 42 is provided at the top of this line. A line 44 connects the chamber 24 with the bottom of the gravity tank 10.

Above the steam valve I provide a vertically extending stem 46, carrying a piston 48 at its lower end loosely fitting a cylinder 50 in which it has vertical movement. This stem carries exhaust valve 60 controlling port 62 and steam supply valve 64 controlling port 66.

Line 68 leads from the top of tank 10 to the upper part of the controlling mechanism just above the exhaust port 62. Steam line 70 leads from the boiler to the top of the control mechanism, and line 72 leads from line 70 to the chamber surrounding the steam valve 32, so that there is always pressure in this chamber.

As explained in connection with Figs. 1 and 2, with the tank 10 filled the diaphragm 26 will flex downwardly unseating the steam valve 32, so that the piston will move upwardly closing the exhaust valve 60 and opening steam valve 64, thereby admitting steam, by way of line 68, to the upper part of the tank 10, so that water therefrom will flow on demand to the boiler. When the tank 10 has been nearly emptied the column of water in the lines 40 and 44 are no longer balanced, so that the pressure on the chamber 36 is sufficiently greater than the load on the upper side of the diaphragm 26 to flex the latter upwardly, closing or seating the steam valve 32. The piston 48 will then drop, opening exhaust valve 60, permitting steam to exhaust to the steam coils 93 of the feed water heater 92 by way of line 94 or elsewhere. This lowers the pressure in the gravity tank 10 sufficiently to permit the same to refill until the lines 40 and 44 are again balanced whereupon the diaphragm 26 will again flex downwardly to begin another cycle of operation. In this embodiment of my invention it is assumed that the water entering the closed heater 92 from an outside source is under sufficient pressure to elevate it to the gravity tank 10, as distinguished from the embodiment of my invention first described.

In the embodiment of my invention illustrated in Fig. 4 I have shown a construction differing from the other embodiments of my invention in that instead of exhausting steam from the gravity tank to the supply tank, to elevate the water from the supply tank to the gravity tank, or instead of having the supply tank connected to a source of water under pressure, I employ steam direct from the boiler through a controllable pressure reducing valve for elevating the water to the gravity tank. By employing a controllable or adjustable reducing valve it will be evident I effect economy in operation, in that I only employ sufficient steam pressure to elevate the water to the gravity tank, whereas were I to employ full boiler pressure this would result in an increased quantity or weight of steam, and an unnecessary increase in cost of operation.

The chamber 24 of this embodiment of my invention is in communication with the bottom of a gravity tank corresponding to tank 10 by line 44. Likewise the chamber 36 below the diaphragm 26 is in communication with the upper part of the gravity tank through line 40. Line 70 direct from the boiler communicates with the top of the control mechanism, and as before line 72 which is tapped off the line 70 is provided to admit steam from the boiler to the chamber 33 about the steam valve 32.

As in the other embodiments of my invention, an unbalance in load at the two sides of the diaphragm 26 due to emptying of the gravity tank causes the diaphragm and steam valve 32 to move upwardly closing the valve 32. As before, live steam valve 64 will close, exhaust valve 60 will open and the steam from the gravity tank instead of exhausting to the supply tank 4 to raise the water therein will exhaust to atmosphere or to the steam coils 100 in the supply tank 4 by way of line 101 or elsewhere. It is to be noted that in the upper part of the control mechanism I have provided a port 102 above the port 66, this port 102 being controlled by reducing valve 104. This valve is spring loaded and its loading spring 106 can be adjusted by adjusting screw 108. With the steam valve 64 closed, as above mentioned, and steam from the gravity tank exhausting to atmosphere or to the steam coils 100, the valve 104 is unseated by steam direct from the boiler, admitted thereto through the line 70 and inasmuch as under assumed conditions the valve 56 is open and valve 52 closed, steam at the desired reduced pressure passes directly to the supply tank 4 by way of line 110 to build up the necessary pressure therein to lift the water therefrom through line 16 to the gravity tank to refill the same. To prevent overfilling of the tank 4 with water and passage of water back through the steam line 110 I provide a float 112 in the tank 4.

In this embodiment of my invention, therefore, as above pointed out, water from the supply tank 4 is raised to the gravity tank by steam pressure direct from the boiler as distinguished from the two other embodiments of my invention above described.

It is to be understood that changes may be made in the details of construction and arrangement of parts herein illustrated and described within the purview of my invention.

What I claim is:

1. A boiler feed system comprising in combination a gravity tank and an intermediate tank for selectively supplying water to a boiler, a steam line from the boiler to the said intermediate tank, a control valve between the intermediate tank and the boiler, a check valve between the intermediate tank and the gravity tank opening toward the intermediate tank, and control means, dependent for operation upon the water level in the gravity tank for controlling the feeding of water to the boiler from the gravity tank and for controlling the refilling of the gravity tank.

2. In combination, a steam boiler, a gravity tank and an intermediate tank for selectively supplying water to the boiler, the intermediate tank being under boiler pressure at all times, a control valve between the intermediate tank and the boiler, a check valve between the intermediate tank and the gravity tank opening toward the intermediate tank, and automatically operable control mechanism for admitting steam from the boiler to the gravity tank when feed water is to be supplied to the boiler from the gravity tank.

3. In combination, a steam boiler, a gravity tank for supplying water to the boiler, a supply tank for supplying water to the gravity tank, control mechanism operable to admit steam to the gravity tank as water is being discharged therefrom, and to exhaust this steam to the supply tank to raise water therefrom to the gravity tank, and control mechanism operable to permit of continued exhausting of steam from the gravity tank when the pressure in the gravity tank and the supply tank become equal while maintaining steam pressure on the supply tank.

4. In combination, a steam boiler, a gravity tank and an intermediate tank for continuously supplying water to the boiler, control mechanism for controlling the supplying of water to the gravity tank, said control mechanism comprising a steam supply valve and an exhaust valve automatically operable to admit steam from the boiler to the gravity tank when the said tank is supplying water to the boiler and to exhaust the steam from the tank when the tank is being refilled, a control valve between the boiler and said intermediate tank, a check valve between the gravity tank and intermediate tank opening toward the intermediate tank, and a steam line from the boiler to the intermediate tank whereby the latter is always under boiler pressure in order that, during the refilling of the gravity tank, water may be supplied to the boiler from the intermediate tank.

5. In combination, a steam boiler, a gravity tank and an intermediate tank for continuously supplying water to the boiler, a control valve between the intermediate tank and the boiler, a check valve between the gravity tank and intermediate tank opening toward the intermediate tank, control mechanism for controlling the supplying of water to the gravity tank, and comprising a steam supply valve and an exhaust valve dependent for operation upon the water level in the gravity tank for admitting steam from the boiler to the gravity tank when the said tank is to supply water to the boiler and to exhaust the steam from the tank when the gravity tank is being refilled, the intermediate tank always being under boiler pressure and available for supplying feed water to the boiler when the gravity tank is being refilled.

6. In combination, a steam boiler, a gravity tank and an intermediate tank for continuously supplying water to the boiler, control mechanism for controlling the supplying of feed water to the gravity tank, and comprising a steam valve, a steam supply valve and an exhaust valve, dependent for operation upon the water level in the gravity tank, for admitting steam from the boiler to the gravity tank when the gravity tank is to supply water to the boiler and to exhaust the steam from the gravity tank when the latter is being refilled, the intermediate tank being connected to the boiler at all times and at all times under boiler pressure so as to supply water to the boiler when the gravity tank is being refilled, a control valve between the intermediate tank and the boiler, and a check valve between the intermediate tank and the gravity tank opening toward the intermediate tank.

7. In combination, a steam boiler, a gravity tank for supplying water to the boiler, control mechanism therefor, said control mechanism comprising a steam supply valve and an exhaust valve, a steam line from the boiler controlled by said steam supply valve for admitting steam at boiler pressure above the water in the said tank

when the gravity tank is to supply water to the boiler, a water supply tank for the gravity tank, and an exhaust line controlled by said exhaust valve for exhausting steam from the gravity tank to said water supply tank for effecting refilling of the gravity tank, and control mechanism operable when the pressure in the gravity tank is equal to the pressure in the supply tank to permit of exhausting of the steam from the gravity tank to the exterior of the apparatus while preventing the escape of steam from the supply tank.

8. In combination a steam boiler, a gravity tank for supplying water to the boiler, a steam inlet valve, an exhaust valve, seating in opposed directions, a steam line connecting the boiler to the top of the gravity tank, said steam inlet valve being in said line, said valves operating automatically, a water supply tank for supplying water to the gravity tank, and an exhaust steam line communicating with said water supply tank, said line being closed by said exhaust valve when the said steam valve is open, closing of the steam valve opening the exhaust valve to exhaust steam from the gravity tank to the water supply tank for refilling of the gravity tank, and control mechanism operable when the pressure in the gravity tank equals the pressure in the supply tank for exhausting steam from the gravity tank to the exterior of the apparatus while preventing the escape of steam from the supply tank.

9. In combination, a boiler, a gravity tank for supplying water thereto, control mechanism comprising an enclosure divided into two chambers by a diaphragm, a weight mounted on the diaphragm, a water conduit extending from each of said chambers to the gravity tank, whereby the hydrostatic loads on the faces of the diaphragm are in approximate balance when the gravity tank is full of water, and the diaphragm will be deflected by said weight, a steam valve attached to

the diaphragm, a cylinder, a piston therein, said valve controlling the admission of steam to said cylinder, a valve stem attached to said piston, a steam inlet valve and an exhaust valve carried by said stem, a steam line from the boiler to said control mechanism and from the control mechanism to the top of the gravity tank, said steam inlet valve opening automatically when the diaphragm is deflected downwardly due to raising of the water level in the gravity tank, and said exhaust valve opening when the diaphragm is restored to its initial upper position, the steam valve closing when the water level in the gravity tank has lowered a predetermined amount.

10. In combination a boiler, a gravity tank for supplying water thereto, control mechanism comprising an enclosure divided into two chambers by a diaphragm, a weight mounted on the diaphragm, a water conduit extending from each of said chambers to the gravity tank whereby the hydrostatic loads on the faces of the diaphragm are in approximate balance when the gravity tank is full of water, and the diaphragm will be deflected by said weight, a valve stem, a steam inlet valve and an exhaust valve carried by said stem, a steam valve attached to said diaphragm for simultaneously controlling the operation of said steam inlet valve and said exhaust valve, a steam line from the boiler to said control mechanism and from the control mechanism to the top of the gravity tank, said steam inlet valve opening automatically when the diaphragm is deflected downwardly due to raising of the water level in the gravity tank and said exhaust valve opening when the diaphragm is restored to its initial position, the steam valve closing when the water level in the gravity tank has lowered a predetermined amount.

OSCAR H. LUDEMAN. 40