



- (51) International Patent Classification: Not classified
- (21) International Application Number: PCT/BG2012/000018
- (22) International Filing Date: 30 July 2012 (30.07.2012)
- (25) Filing Language: English
- (26) Publication Language: English
- (30) Priority Data: 111007 2 August 2011 (02.08.2011) BG
- (72) Inventor; and
- (71) Applicant : BAHNEV, Boyan Kirilov [BG/BG]; 40, Kapitan Raytcho Str., 4000 Plovdiv (BG).
- (74) Agent: SHENTOVA, Violeta Varbanova; 11, Damyana Gruev Str., 1606 Sofia (BG).
- (81) Designated States (unless otherwise indicated, for every kind of national protection available): AE, AG, AL, AM, AO, AT, AU, AZ, BA, BB, BG, BH, BN, BR, BW, BY, BZ, CA, CH, CL, CN, CO, CR, CU, CZ, DE, DK, DM, DO, DZ, EC, EE, EG, ES, FI, GB, GD, GE, GH, GM, GT, HN, HR, HU, ID, IL, IN, IS, JP, KE, KG, KM, KN, KP,

KR, KZ, LA, LC, LK, LR, LS, LT, LU, LY, MA, MD, ME, MG, MK, MN, MW, MX, MY, MZ, NA, NG, NI, NO, NZ, OM, PE, PG, PH, PL, PT, QA, RO, RS, RU, RW, SC, SD, SE, SG, SK, SL, SM, ST, SV, SY, TH, TJ, TM, TN, TR, TT, TZ, UA, UG, US, UZ, VC, VN, ZA, ZM, ZW.

(84) Designated States (unless otherwise indicated, for every kind of regional protection available): ARIPO (BW, GH, GM, KE, LR, LS, MW, MZ, NA, RW, SD, SL, SZ, TZ, UG, ZM, ZW), Eurasian (AM, AZ, BY, KG, KZ, RU, TJ, TM), European (AL, AT, BE, BG, CH, CY, CZ, DE, DK, EE, ES, FI, FR, GB, GR, HR, HU, IE, IS, IT, LT, LU, LV, MC, MK, MT, NL, NO, PL, PT, RO, RS, SE, SI, SK, SM, TR), OAPI (BF, BJ, CF, CG, CI, CM, GA, GN, GQ, GW, ML, MR, NE, SN, TD, TG).

**Declarations under Rule 4.17:**

— of inventorship (Rule 4.17(iv))

**Published:**

— without international search report and to be republished upon receipt of that report (Rule 48.2(g))

(54) Title: CAM ENGINE

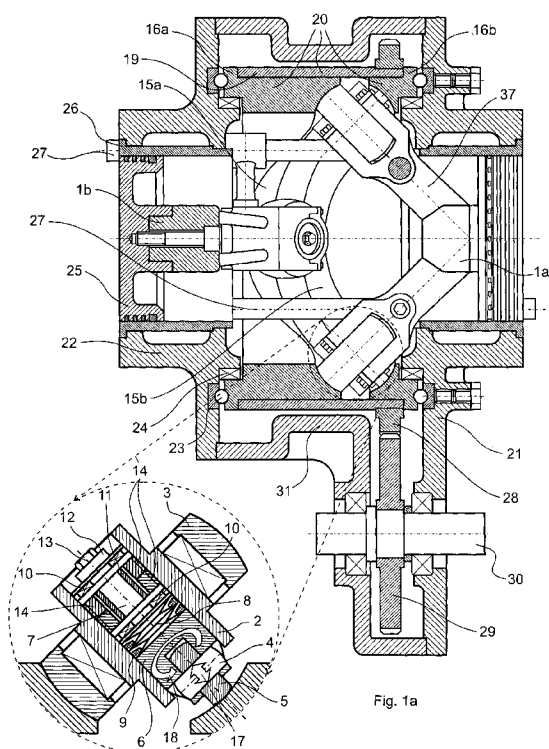

(57) Abstract: The invention relates to a cam engine used in different field of the mechanical engineering, as internal-combustion engines, compressors, pumps etc. The cam engine comprises cylinders (26) with pistons (25), cylindrical tubular 3D cam (20) having a cam groove on the inner cylindrical surface and at least two asynchronously moving followers (1a and 1b) with arms (37) having main and additional rollers (3, 5).

## CAM ENGINE

### FIELD OF THE INVENTION

The invention relates to a piston cam engine and particularly to an  
5 opposed-piston cam engine that may find application in different fields of mechanical  
engineering, e.g. internal combustion engines, compressors and etc. Engines,  
constructed according to this invention, could be used in various land, water and air  
vehicles, as well as in stationary aggregates.

### 10 BACKGROUND OF THE INVENTION

One of the common problems of the cam mechanisms is the  
relatively more rapid wear in comparison to the mechanisms which links are connected  
by hinged joints.

The main reasons for the intensive wear of cam mechanisms are  
15 friction between the cam surface and the element, which is in contact with it; greater  
contact force transmitted by a very small area between the cam profile and the element  
in contact with the cam; as well as a break of contact between the cam and the element  
contacting with its profile and subsequent impact recovery of the contact between them.

Wearing of the cam mechanisms can be reduced to different extent,  
20 depending on the requirements to the cam engine and the intended function of the cam  
mechanism in the given engine.

It is known from EP19379388 a cam engine comprising a housing,  
at least one cylinder, at least one piston moving in the cylinder, a cylindrical tubular 3D  
cam with a cam groove on the inner cylindrical surface, which groove is made so that the  
25 line forming its cross-section is a straight or concave line whose lower end is located at  
the side towards the axis of the 3D cam, and at least two equal-mass follower positioned  
against each other, at least one of which is a working follower, where each follower  
comprises at least two arms standing at an angle to each other and having main rollers  
bearing at the free ends of the corresponding arm, and each follower also comprises  
30 additional rollers that can move along the axes of the corresponding main rollers, so that  
each main and additional roller contacts the cam groove. The problem of the intensive  
wear of the cam mechanism of this known engine is comparatively well settled. In this

case each follower is provided not only with main rollers, but also with additional ones, which contact with the profile of the cam groove opposing the cam profile with which the additional rollers of the same follower are in contact. The additional rollers are elastically connected to their respective follower and press it to the cam profile of its adjacent main  
5 rollers. This design solution is able to provide constant contact between the followers and their respective cam profiles, if the elastic elements of the additional rollers are hard enough to counteract the effect of the inertia forces of the followers when inertia forces act to interrupt the connection of the followers and the cam. On the other hand, the additional rollers have considerably smaller diameters than the diameters of the main  
10 rollers and the cam groove is characterized with constant cross-section, due to which each additional roller will be constantly moving along the axis of its respective main roller when each of them follows the adjacent cam profile. Therefore, each elastic element that presses its corresponding additional roller will constantly shrink and stretch. The shrinking and stretching of the elastic elements will cause unsteady operation of the cam  
15 mechanism, which causes altering moments of acceleration and slowdown of the rotation of the main transforming 3D cam. The movement of the known cam mechanism is insofar uneven as the difference between the diameters of the main and additional rollers.

Additionally, in this known piston cam engine there is some loss  
20 resulting from the constant shrinking and stretching of the elastic elements, as well as loss resulting from the friction between the additional rollers and the cam profiles. The loss resulted from the friction of the additional rollers in the known engine is due to the fact that they cannot self-adjust while rolling along the corresponding cam profiles, since they only move reciprocally along the axis of the main rollers. As a result friction forces  
25 are generated, which cause mechanical loss and wear of the cam mechanism.

Moreover, in this known cam engine, the movement of the additional  
rollers along the axis of the main rollers is not limited, and thus the use of elastic  
elements with high hardness and preload is necessary to be applied in order to prevent  
interruption of contact between the cam and followers when there are inertia forces  
30 acting towards their disconnection. When the inertia forces are not aiming to break the contact between the cam and the followers, the additional rollers will be pressed by the

elastic elements to their adjacent cam profile with unnecessarily large forces, leading to a faster wear of the cam profile.

This known patent EP19379938 also discloses laws of motion of the piston cam engine, due to which its operation is improved. These laws, however, do not completely guarantee the contact between the followers and the main transforming cam.

## SUMMARY OF THE INVENTION

The problem solved by the present invention is to provide technical solutions that improve the functional reliability of the apparatuses having a cam mechanism and in particular piston cam engines.

These and other problems are solved by a cam engine comprising a housing, at least one cylinder, at least one piston moving in the cylinder, cylindrical tubular 3D cam with a cam groove on the inner cylindrical surface, which groove is made so that the line forming its surface cross-section is a straight or concave line whose lower end is located at the axis of the 3D cam, and at least two asynchronously moving equal-mass followers, positioned against each other, at least one of which pistons is a working piston. Each follower comprises at least two arms, standing at an angle to each other and having main rollers bearing at the free ends of the corresponding arm, and each follower also comprises additional rollers that can move along the axes of the corresponding main rollers, so that each main and additional roller contacts the cam groove. Besides the additional rollers have the possibility to rotate in relation to the axes of their corresponding main rollers, so that they are able to self-adjust to achieve rolling without sliding. Thus, the additional rollers can move in parallel and rotate around the axes of their corresponding main rollers at the same time, whereat a rolling without sliding takes place. The additional rollers include stoppers for limiting their movement along the axes of the main rollers, which additionally reduces the possibility of breaking the contact between the main rollers and their corresponding cam profiles without the preloading of the elastic elements used being too high. Thus, the movement of the additional rollers is kept within acceptable limits. The cam groove is characterized with periodically changing cross-section, depending on the number of the convex and concave sections of the profile of the 3D cam. This reduces the linear movement of the additional rollers compared to the corresponding main rollers.

In one embodiment of the invention, the cam engine has a cam groove, which is made so that at the top and bottom dead centers the distance between the cam profiles of the groove of the 3D cam in the cross-section is the greatest, and the distance in the cross-section between the cam profiles of the groove of the 3D cam  
5 between the two dead centers is the smallest. This reduces to the maximum possible extent the movement of the additional rollers in comparison with the axes of their corresponding main rollers. When the cam groove is shrinking, the distance between the centers of the axes of each pair of main and additional rollers remains constant and therefore the relative movement between any additional roller and the corresponding  
10 main bearing journal is eliminated.

In another embodiment of the invention, the cam groove is realized in such a way that along the lines of rolling of the rollers narrower grooves are made so that their greatest depth is at the top and the bottom dead centers, and that between the two dead centers their depth is zero is minimum, so that the movement of the additional  
15 rollers along the axes of the main rollers to be maximum reduced. In one alternative embodiment, the cam groove is made in such a way that along the lines of rolling of the rollers there are narrower convex paths made so that the height of these paths is the greatest between the top and the bottom dead centers, and that at the top and bottom dead centers their height is minimum, so that the movement of the additional rollers  
20 along the axes of the main rollers to be maximum reduced. These alternative forms allow using a different approach to reduce maximally the moving of the additional rollers along the axes of the main rollers.

In another embodiment of the invention there are at least two main rollers mounted at the free end of each arm of the followers, which are independently  
25 bearing to the corresponding arm of the follower. This allows the main rollers which are mounted on a single axis to rotate at different revolutions, regardless of the fact that they interact with the same cam profile.

In another preferred embodiment of the invention, the 3D cam is composite and comprises two coaxial bushings, each having a corrugated cam profile on  
30 one side, and the cam bushings are spaced from one another with their corrugated edges positioned so that the convex parts of the cam profile of the one of the bushings stand against the concave parts of the cam profile of the other bushing. Besides it also

comprises at least two leading columns for reciprocating linear motion of each piston, which columns are parallel and equidistant to the axis of the 3D cam.

In another preferred embodiment of the invention the corrugated cam profile is made so that its curve of the law of motion of the followers in function of the angle of rotation of the 3D cam is formed by consecutively alternating ascending and descending sections, whose connection results in equal number of convexities and concavities, the total number of which is equal to or multiple by the sum of the number of arms of the followers. Thus, the curve is continuous at least up to its second derivative in one complete rotation of the cam at  $360^{\circ}$ , including for both end points. Such cam profile guarantees that the velocities and accelerations of the followers at the end of each ascending and descending section are equal to their velocities and accelerations at the beginning of the next section, due to which a smooth transition of the followers when changing their direction of movement is achieved. Moreover, the curve is symmetrical for each two adjacent sections, descending and ascending, i.e. the straight line, that passes through the connection point of two adjacent sections, is perpendicular to the tangent to the curve at this point represents the axis of symmetry for these sections. Such cam profile provides that the opposed main rollers of one follower are in simultaneous contact with their corresponding cam profile.

In still another preferred embodiment of the invention, each ascending and descending section of the curve has one maximum and one minimum value of its second derivative, which do not coincide with the end points of the respective section. Thus, low velocities of the pistons are achieved around their dead center positions. In a more preferred embodiment, the values of the second derivative of the curve are equal to zero at the connection points of each two adjacent sections. In this way, the velocity of the pistons around their dead centers is reduced even further. Most preferably, identical straight sections are included in the area of the points of junction of the curve. By such a curve of the cam law, a maximum possible slowdown of the pistons around their dead centers is achieved.

In another embodiment of the invention, the cam engine also comprises an electrical rotor, rigidly connected to the 3D cam and a stator, rigidly connected to the housing of the engine, in order to realize a combination between a piston engine and an electrical engine. The electric engine functions as an electric

motor or a generator, depending on the type of output energy – electrical energy or energy derived from the work of the piston engine. Such a combined engine is compact and has a low manufacturing cost, since it does not need independent housing and storage for the electrical engine.

5                   In one another embodiment of the invention the cam engine comprises also an input and/or output shaft, an electric rotor, rigidly connected to the incoming and/or outgoing shaft and a stator, rigidly connected to the housing in order to realize a combination between a piston engine and an electrical engine. This embodiment allows generating from or imputing to the piston cam engine not only  
10 electrical, but also mechanical energy.

                  In one subsequent embodiment of the invention, the cam engine also comprises means to deliver and discharge of working fluid.

                  In still another embodiment of the invention at least the main and additional rollers are external bearing rings of composite bearings, including multiple  
15 bearing rings with different diameters, arranged concentrically to each other and the connection between them is either sliding or via rolling bodies. Thus the friction forces in the composite bearings are reduced.

                  The invention also relates to a compressor or a pump that comprises at least one cam engine described above.

20                   The present invention also relates to a motor that includes at least one cam engine presented in the above described embodiments. In one embodiment, the motor also includes at least one kinematic chain having a 2D cam connected to the 3D cam; at least one intake or exhaust valve located in a cylinder head; a rocker that is connected by means of cylindrical joint to a stationary component of the engine, and the  
25 rocker has one arm by which it makes a contact with the 2D cam, and at least one other arm, each contacting with an intake or exhaust valve.

                  In another embodiment the motor also comprises a supercharging mechanism having at least one valve for opening the housing to let the atmospheric air in when the pistons are moving apart, located on the housing, and at least one 2D cam  
30 for managing the movement of the valve, which 2D cam is mounted to the 3D cam.

                  In still another embodiment the motor includes a supercharging mechanism, comprising at least one diaphragm pump, positioned on the housing of the

- 7 -

motor for compressing the atmospheric air in the intake manifold of the motor, and at least one 2D cam to activate the motion of the diaphragm pump, which 2D cam is fixed to the 3D cam.

In another embodiment of the motor, it comprises one operating  
5 cylinder, functioning as a heat engine, and one opposed cylinder, functioning as a compressor or a pump. In one preferred embodiment of the motor, the opposed cylinder is a cylinder of a compressor and also having a pneumatic accumulator for feeding the operating cylinder with at least a part of the compressed air from the opposed cylinder and for keeping the air and/or for preparing the fuel-air mixture for the next working cycle  
10 of the operating cylinder.

Thus, the motors disclosed above function more effectively and reliably, while realizing a split working cycle, compared to engines that realize split cycle with a traditional crank mechanism. While realizing a split cycle of the functioning of the engine, one of its cylinders is used only for the suction and compression of the working  
15 fluid, and the combustion process, expansion and release of exhaust gases are taking place in the other cylinder.

The field of utilization of the cam engine of the invention expands in case the latter is realized as any kind of combination of internal combustion engine, pump, compressor, electric motor and generator. These combinations are preferable,  
20 when different types of energy are in demand. In this case, the 3D cam represents a means for receiving or transmitting mechanic and/or electrical energy.

In the cases, when using engines with a small working volume is necessary, it is beneficial the cam engine to have one operating cylinder. In this case, one of the two operating cylinders and his relevant piston, head and means for delivery  
25 and discharge of the working fluid are removed. In place of the piston, a balancing component is mounted in such a way that the weight of the follower with the piston equals the weight of the follower with the balancing component.

In other cases, when using engines with a large working volume is necessary, the integration of several piston cam engines, connected by means of their  
30 tooth gears transmitting the rotary motion of their composite cams to at least one outgoing shaft of the engine, is appropriate.

## BRIEF DESCRIPTION OF THE DRAWINGS

**Fig.1a** shows two-piston cam engine with additional rotational degree of freedom for its additional rollers;

**Fig.1b** shows positioning nut – limiting component for the elastic elements;

5 **Fig.1c** shows bearing assembly of a pair main and additional roller with a stop element that limits the movement of the additional bearing roller in relation to its main bearing journal;

**Fig.2a, Fig.2b and Fig.2c** show location of one pair main and additional rollers in case of a cam groove with a constant cross-section;

10 **Fig.3a and Fig.3b** show example of a modified law and acceleration of a cam with a variable cross-section;

**Fig.4a, Fig.4b and Fig.4c** show location of one pair main and additional roller in case of a cam groove with a variable cross-section;

15 **Fig.5** shows mutual disposition of the laws of the cam profiles of the opposed cam bushings in case of grooves with variable cross-section;

**Fig.6a, Fig.6b and Fig.6c** show cam bushings with narrower grooves for the additional rollers;

**Fig.7** shows main bearing roller with concave profile and convex path;

20 **Fig.8** shows example in which two main rollers are mounted on one main bearing journal;

**Fig.9** shows composite bearing;

**Fig.10** shows rocker of piston cam engine that can simultaneously set two valves in motion;

**Fig.11a, Fig.11b and Fig.11c** show mechanisms for decompression;

25 **Fig.12** shows two-piston cam internal combustion engine charged with fresh working substance, passing through its housing;

**Fig.13** shows two-piston cam internal combustion engine charged by means of diaphragm pump;

30 **Fig.14** shows two-piston cam internal combustion engine combined with electric engine;

**Fig.15** shows two-piston cam internal combustion engine with split cycle.

**Fig.16** shows properties of the law of the followers of the cam engine without

modification of the law according to Fig.3a and 3b;

**Fig.17a** and **17b** show laws of the followers and their second derivatives that are not interrupted and whose extreme values are not located with the ends of any ascending or descending section of the law without modification of the law according to Fig.3a and 3b;

**Fig.18a** and **18b** show a law of the followers and their second derivatives with rectilinear horizontal sections in each location of the curve of the law corresponding to a dead center of the pistons, without modification of the law according to Fig.3a and 3b.

## 10 DETAILED DESCRIPTION OF THE INVENTION

According to the invention, different two- or one-piston cam engines can be realized, which execute different working cycles depending on the specific application of the engine that can function as a compressor, pump, internal combustion engine or a combination of the above-mentioned.

**Fig.1a** and **Fig.1b** show one embodiment of two-piston cam engine according to the invention. The engine comprises a tubular 3D cam **20**, which is an assembly of cam bushings **16a** and **16b** and a tubular element **19** that orientates cam bushings **16a** and **16b** in such a way that their cam profiles **15a** and **15b** form a cam groove on the internal surface of the 3D cam **20**. The engine comprises two identical followers **1a** and **1b** as well, each one of them having two arms **37**. To the free ends of the arms **37**, which in this case are shaped as bearing forks, main bearing journals **2** and main rollers **3** are mounted. The main bearing journals **2** are of tubular geometry and in their cylindrical cavities additional bearing journals **4** and additional rollers **5** are located. The additional bearing journals **4** are mounted on cylindrical plungers **6**, which have cylindrical tails **7**. A group of belleville springs **8**, limiting rings **9**, two axial bearings **10**, spacers, respectively **11** and **12**, are mounted on each plunger tail **7**, and by a screw **13** these elements **8** to **12** are pressed on both sides of two positioning nuts **14**, shown on **Fig.1b**. The positioning nuts **14** mutually secure themselves against self-unscrewing. On their two sides the axial bearings **10** are mounted that allow the free rotation of the additional bearing roller **5** and the self-aligning of the same in relation to its respective cam profile **15b** possible. Thus the additional bearing roller **5** has two relative degrees of freedom in relation to bearing journal **2**, namely one translational along the axes **17**

and one rotational **18**. Through the translational degree of freedom **17**, the additional roller **5** is in continuous contact with the respective cam profile **15b**, and through the rotational degree of freedom **18** the additional roller **5** is self-oriented towards the profile **15b** in such a way, that the relative motion of the additional roller **5** towards the adjacent cam profiles **15b** is the only rolling without sliding. The main rollers **3** of the followers **1a** and **1b** contact the cam profiles **15a** and **15b** of the cam bushings **16a** and **16b** respectively. The 3D cam **20** is mounted in cylinder blocks **21** and **22** through one axial and one radial bearings **23** and **24** at each side. Each follower is connected to one piston **25**, which is situated in the respective cylinder **26**. The axes of cylinders **26** coincide with the axis of the composed cam **20**. The axial guidance of the followers is accomplished by guiding columns **27**, mounted on bearings in cylinder blocks **21** and **22**. The reciprocal motion of followers **1a** and **1b** is transformed into rotation of the 3D cam **20**, which transfers the rotational motion to a gear **28**, which is rigidly connected to the 3D cam **20**. The gear **28** is coupled with a gear **29**, which sets into motion an output shaft **30**. The shaft **30** is positioned on bearings in the cylinder block **21** and the housing **31**.

**Fig.1c** presents a second constructive option of the bearing assembly of a pair main and additional roller. This assembly, unlike the one presented in Fig.1a, is equipped with the additional stop element **43**, which functions as the limiting rings **9** in Fig.1a. The stop element **43** does not allow the movement of the pack of elements **8 – 12** to exceed the limit, preset by its position. In this specific case, the stop element is the adjustable screw **43**, screwed in plate **44**, which in turn is mounted on the internal end of the main bearing journal **2**. Through screw **43**, secured against self-unscrewing by counter nut **45**, the maximum admissible clearance is preset between the face of screw **43** and the head of screw **13**. The clearance is preset, when follower **1a** or **1b** is at the top and bottom dead centers, and the size equals the maximum relative movement of the additional rollers in relation to their respective main bearing journals. The design alternative presented in this figure makes it possible to accomplish a more precise adjustment of limiting clearance.

A preferred way to achieve a periodically changing cross-section of the 3D cam groove is to modify the cam profiles law, which can be achieved by summation of the law, in which the cam groove has a constant cross-section, with the

half of a law which is the imaginary axial movement of the cam bushing one to another as a function of the angle of rotation of the 3D cam. The modification is made so that the relative movement between any additional roller and its corresponding bearing journal is eliminated. When summing up these laws, the cam groove transforms to a groove with a variable cross-section. An acceptable approximation of the modifying function is any continuous function of the angle of rotation of the 3D cam that reduces the relative movement between each additional roller and its corresponding main bearing journal, and that also does not cause interruption of the resulting law after its summation with the primary law in the case of which the cam groove has a constant cross-section.

**Fig.2a, Fig.2b and Fig.2c** clarify the reasons for the appearance of the relative movement of the additional rollers **5** in relation to their respective main bearing journals **2** when the 3D cam **20** is rotating and it has constant cross-section of the cam groove. **Fig.2a** illustrates the mutual disposition of one pair main and additional rollers, respectively **3** and **5**, in cross-sections of the cam groove corresponding to the top and bottom dead centers (TDC/BDC) of pistons **25**. **Fig.2b** shows the cross-sections of the cam groove, corresponding to one intermediate angle of rotation of the 3D cam **20** between the top and bottom dead centers of the pistons **25**. **Fig.2c** shows 1/4 of the unfolded cam profiles **15a** and **15b**, on which a pair of main and additional roller are located in TDC and BDC (positions I), as well as their positioning when the followers are not located in TDC or BDC. Thus, in TDC and BDC of pistons **25** the contact cross-sections of the rollers **3** and **5** with the respective cam profiles **15a** and **15b** are located on the same cross-section of the cam groove and the distance between their midpoints **41** and **78** is minimum and equal to L (**Fig.2a** and **Fig.2c**, position I). When the pistons **25** are not in TDC or BDC, the contact cross-sections of rollers **3** and **5** together with the respective cam profiles **15a** and **15b** are not located on the same cross-section of the 3D cam **20** (**Fig.2b** and **Fig.2c**, positions II and III). It is obvious, that if the distance between midpoints **41** and **78** of the axes of the rollers **3** and **5** remains equal to L, the roller **5** would not be in contact with cam profile **16b**. Hence, in order to provide simultaneous contact of the rollers **3** and **5** with the adjacent cam profiles **15a** and **15b**, and to keep unchangeable the distance between midpoints **41** and **78** of the axes of the rollers **3** and **5** (equal to L), when the pistons **25** are situated

between TDC and BDC, the cam bushings **16a** and **16b** have to be put close to each other, and when the pistons **25** get near to their dead centers, cam bushings **16a** and **16b** have to be pulled back. The maximum displacement of the bushings **62** is marked with  $\Delta H$  on **Fig.2b**.

5                   **Fig.3a** and **Fig.3b** show a way to remove or significantly decrease the relative moving of additional rollers **5** in relation to their respective main bearing journal **2**. This way is associated only with modification of the law of motion of the followers **1a** and **1b**, by which the cam profiles **15a** and **15b** are manufactured respectively of the cam bushings **16a** and **16b**. According to the invention, it is desirable  
10 that the modification of the law of the followers **1a** and **1b** to be realized by summing the unmodified law **33**, where the cam groove is with a constant cross-section, with an approximation of a modifying law **34**, the maximum of which is equal to the half of the maximum displacement  $\square H$  in **Fig.2b**. Using of the approximation of the modifying law **34** instead of an actual modifying law is acceptable when the approximating law **34** can  
15 be presented analytically using one or more formulas and its application instead of the actual modifying law decreases the relative displacement of the roller **5** in relation to its respective main bearing journal **2**, compared to the case in which the 3D cam **20** has a constant cross-section. The residual displacement after the application of the approximating law **34** causes shrinking and expansion of the group of the belleville  
20 springs **8**, but with considerably smaller energy consumption in comparison with the case, when the law of the followers is not modified. The shrink of springs **8** is limited by the thickness of limiting rings **9** or the position of screw **43**. It can be seen in the figures, that the resulting law is continuous to its second derivative and its shape and nature are slightly changed after its modification.

25                   **Fig.4a**, **Fig.4b** and **Fig.4c** are analogous to **Fig.2a**, **Fig.2b** and **Fig.2c** and show the changes that occur in the mutual disposition between each pair of the rollers **3** and **5** after the modification of the law **33** of the cam profiles **15a** and **15b**, mentioned above. It is obvious from the figures that the rollers **3** and **5** are in a permanent contact with their respective cam profiles **15a** and **15b** without changes in the  
30 distance between the midpoints **41** and **78** of their axes. The law of cam profile **15a** is shown in **Fig.4c** with a dash line **35a** and the law of profile **15b** - with an axial line **35b**. In the same **Fig.4c**, the profile of unmodified cam bushings is shown with dotted line,

which illustrates the difference between unmodified cam groove with constant cross-section and modified cam groove with altering cross-section. This figure makes it clear that the cross-section of a modified cam groove decreases, excluding the places, which correspond to the dead centers of the followers **1a** and **1b**. The maximum decrease characterizes those places of the cam groove that are in the middle of the sections between the dead centers of the followers **1a** and **1b**.

**Fig.5** shows the laws of motion of the followers **1a** and **1b** for a complete rotation ( $360^0$ ) of 3D cam **20**. The law **35a** of the follower **1a** is drawn by a continuous line and the law **35b** of the follower **1b** – by a dash line. The law **35a** is identical to law **35b**, but for the purposes of illustration, the law **35b** is twice rotated in an inversed manner in relation to the horizontal and the vertical axes and is laid on law **35a** in such a way, that the dead positions of the followers coincide. When the laws of cam bushings **16a** and **16b** are not modified and the cam groove is with a constant cross-section, the law **35a** coincides with the law **35b**.

The modified laws **35a** and **35b**, presented in **Fig.5** are composed based on a sine function:

$$S(\varphi)_{33} = \frac{H}{2} - \frac{H}{2} \cdot \sin\left(\frac{\pi}{2} + 2\varphi\right),$$

that functions as the law 33, in which the cam groove has a constant cross-section and a cycloid function:

$$S(\varphi)_{34} = \Delta H \cdot \left[ \frac{\varphi}{\beta} - \frac{1}{2\pi} \cdot \sin\left(2\pi \frac{\varphi}{\beta}\right) \right],$$

used in this case as approximate modifying law **34**, where  $\varphi$  is the rotation angle of cam **20**;  $S(\varphi)$  is motion law of executive units;  $H$  is the stroke of the piston; and  $\beta$  is the rotation angle of the 3D cam **20** when the law **34**, shown in **Fig.3a**, **Fig.3b** and **Fig.5**, reaches its maximum.

In the described example, the pistons **25** execute four strokes per a revolution of the 3D cam **20**. The table below presents the specific forms of the functions for each section of the law of the follower **1a**.

| Number, type and range of the section                    | Law 33   | Modifying law 34  |
|--|--|---|
| 1. Ascending<br>$0 \leq \varphi \leq 45^\circ$           | $S_{33} = \frac{H}{2} - \frac{H}{2} \cdot \sin\left(\frac{\pi + 2\varphi}{2}\right)$ | $S_{34} = \frac{\Delta H}{2} \left[ \frac{\varphi}{\beta} - \frac{1}{2\pi} \cdot \sin\left(2\pi \frac{\varphi}{\beta}\right) \right]$                               |
| 2. Ascending<br>$45^\circ \leq \varphi \leq 90^\circ$    |  | $S_{34} = \frac{\Delta H}{2} - \frac{\Delta H}{2} \left[ \frac{\varphi - \beta}{\beta} - \frac{1}{2\pi} \cdot \sin\left(2\pi \frac{\varphi}{\beta}\right) \right]$  |
| 3. Descending<br>$90^\circ \leq \varphi \leq 135^\circ$  |  | $S_{34} = \frac{\Delta H}{2} \left[ \frac{\varphi}{\beta} - \frac{1}{2\pi} \cdot \sin\left(2\pi \frac{\varphi}{\beta}\right) \right]$                               |
| 4. Descending<br>$135^\circ \leq \varphi \leq 180^\circ$ |  | $S_{34} = \frac{\Delta H}{2} - \frac{\Delta H}{2} \left[ \frac{\varphi - 3\beta}{\beta} - \frac{1}{2\pi} \cdot \sin\left(2\pi \frac{\varphi}{\beta}\right) \right]$ |
| 5. Ascending<br>$180^\circ \leq \varphi \leq 225^\circ$  |  | $S_{34} = \frac{\Delta H}{2} \left[ \frac{\varphi - 4\beta}{\beta} - \frac{1}{2\pi} \cdot \sin\left(2\pi \frac{\varphi}{\beta}\right) \right]$                      |
| 6. Ascending<br>$225^\circ \leq \varphi \leq 270^\circ$  |  | $S_{34} = \frac{\Delta H}{2} - \frac{\Delta H}{2} \left[ \frac{\varphi - 5\beta}{\beta} - \frac{1}{2\pi} \cdot \sin\left(2\pi \frac{\varphi}{\beta}\right) \right]$ |
| 7. Descending<br>$270^\circ \leq \varphi \leq 315^\circ$ |  | $S_{34} = \frac{\Delta H}{2} \left[ \frac{\varphi - 6\beta}{\beta} - \frac{1}{2\pi} \cdot \sin\left(2\pi \frac{\varphi}{\beta}\right) \right]$                      |
| 8. Descending<br>$315^\circ \leq \varphi \leq 360^\circ$ |  | $S_{34} = \frac{\Delta H}{2} - \frac{\Delta H}{2} \left[ \frac{\varphi - 7\beta}{\beta} - \frac{1}{2\pi} \cdot \sin\left(2\pi \frac{\varphi}{\beta}\right) \right]$ |

Fig.6a, Fig.6b and Fig.6c show one another way to keep the distance between the midpoints 41 and 78 of the axes of one pair of the main and additional rollers, respectively 3 and 5 practically constant, without moving the cam bushings 16a and/or 16b and when the 3D cam 20 is rotating. To achieve this objective, additional cam narrower grooves 32 for the additional rollers 5 are carved on cam profiles 15a and 15b. The depth of the additional grooves h is maximal at the places corresponding to TDC or BDC of pistons 25 and is equal to zero between any neighboring dead centers. In this case the cam bushings 16a and 16b are situated closer one to another ( $\Delta H$ ) compared to the case in which the cam paths are convex (see Fig.7, convex path 90). The law, by which cam profiles 15a and 15b are realized, coincides with the unmodified law 33. In case of convex path 90 (see Fig.7), the maximum height is between any neighboring dead centers.

**Fig.7** shows one main roller **3** having a concave profile, which is suitable when additional convex paths **90** are made for additional roller **5**. These paths **90** are standing out in relation to cam profiles **15a** and **15b**.

**Fig.8** shows an example, where each main bearing roller **3** is replaced by two main rollers **3a** and **3b** that are mounted on one main bearing journal **2**. Between the main bearing rollers **3a** and **3b**, mounted on one main bearing journal **2**, the axial roller **36** is situated, which prevents the direct contact between rollers **3a** and **3b**. The basic intention of this solution is to enable the rollers **3a** and **3b**, mounted on one bearing journal, to rotate with different angular rates without friction between them. The advantage is the decreased friction between the main rollers **3a** and **3b** and the cam profile that contacts the rollers. When only one main bearing roller **3** is mounted on the bearing journal **2**, the friction between the roller **3** and the corresponding cam profile is higher, because the peripheral points of roller **3** do not have the possibility to harmonize their velocities in relation to the different velocities of their adjacent contact points of the corresponding cam profile **15a** or **15b**.

**Fig.9** illustrates the realization of one composite bearing **76**, which can be used as means of connecting the main and additional rollers **3** and **5** with the corresponding bearing journals. It will be appropriate also to use composite bearings at the places of contact between rockers **48** and valve-timing cams **52** (**Fig.12** and **Fig.13**). It is obvious from the figure that the composite bearing **76** comprises three bearing rings **63** with different diameters, which are concentrically located to each other. Between them rolling bodies **64** are placed, which decrease the forces of friction while the composite bearing is rolling. It is obvious that the net angular velocity of the composite bearing is a sum of the relative angular velocities of each roller level compared to the preceding. Using composite bearings at the places of the piston cam engine mentioned above makes it possible to increase the angular velocity of all its rotational elements without this to cause accelerated wear of the bearings in question.

**Fig.10** shows one rocker **48** of a piston cam internal combustion engine according to the invention, the purpose of which is to actuate simultaneously two valves **49**. It can be seen from the figure that the rocker comprises one arm **50** with roller **51**, which contacts one 2D cam **52a** or **52b**, shown in **Fig.12**, **Fig.13** and **Fig.15**; two arms **53** with adjusting screws **54** and counter nuts **55**, used to realize the contact

between the rocker **48** and the respective valves **49a** or **49b**, which can be seen in **Fig.12**, **Fig.13** and **Fig.15**; and the cylindrical joint **56**, by means of which the rocker **48** is connected to a static element of the engine.

**Fig.11a** shows an example of a decompression mechanism according to the invention. This mechanism includes an electromagnet **65**, which armature **66** is profile-wisely connected to rocker **48** of one suction or discharge valve **49a/49b** of the valve-timing mechanism of the engine. In this case, the armature **66** of the electromagnet **65** ends with roller **67** that contacts with the arm **53** of the rocker **48**, and a coil **68** of the electromagnet **65** is rigidly connected to the static body element **38**.  
5 When the piston engine is in a starting mode, the armature **66** of the electromagnet **65** presses the arm **53** that on its turn actuates its adjacent valve **49a/49b**, and compresses its spring **69** as well. In this way no compression is realized in the cylinder by the decompression mechanism. When the number of revolutions (RPM) of the engine becomes high enough to overcome the resistance of compression in its cylinders, the  
10 electromagnet **65** is deactivated. This mechanism can be realized by simplified variations of the basic option, described bellow.

**Fig.11b** illustrates one of these options. It includes the electromagnet **65**, a additional decompression valve **71**, different from the valve-timing mechanisms **49a/49b**, and a retracting spring **72**. In this case the armature **66** directly  
20 affects the decompression valve **71**, which opens or closes opening **77** and shrinks and releases its adjacent retracting spring **72**. The function of this example of the decompression mechanism is identical to that of the basic variant of the mechanism. This example is applicable when the combustion chamber **70** is large enough to provide enough space for the decompression valve **71**.

In **Fig.11c** a subsequent example of the decompression mechanism is presented, which comprises the electromagnet **65**, the function of which is to keep the rocker **48** in a position, when the respective suction or discharge valve or valves  
25 **49a/49b** are opened and prevent the compression in their adjacent operating cylinder. In this case, the free end of the armature **66** is linked to a conical element **73** that is in contact with the axis **56** of the rocker **48** and the conical element **73** retains the rocker **48**  
30 in such a position, that keeps the corresponding valve or valves **49a** and/or **49b** opened up to the desirable moment. The axis **56** of rocker **48** has a conical section **74** at its

opening, and thus the rocker **48** transfers a moment of rotation from arm **50**, contacting its respective valve-timing cam, to arms **53**, contacting their adjacent valves.

**Fig.12** illustrates a variant of a piston cam engine, which in this case is realized as two-piston internal combustion engine. In this variant the spaces of the engine housing and the intake manifold **38** are connected. As a result of this connection the charging of cylinders **26** is improved, because the pressure in the engine housing is higher than the atmospheric pressure. The enhanced housing pressure is due to the synchronous bringing near of pistons **25** when valve **39** is closed. In the opposite movement of the pistons **25** a fresh working substance is sucked up from the environment, and enters the engine housing space through the valve **39** and filters **40**. Valve **39** is activated by two 2D cams **45**, which are rigidly connected to the 3D cam **20**.

**Fig.13** shows next example, by which it is improved the fresh working fluid charging of a two-piston internal combustion engine according to the invention. For this purpose, a diaphragm pump **46** is added to the construction of the engine, whose plunger **47** and the diaphragm **58** are put into action by two 2D cams **45**, and the flow of fresh working fluid is directed straight from the pump to the intake manifold **38**. The flow of fresh working fluid is guided by a system of one-way check valves **59**. To prevent the excessive increase in the pressure of the housing space, it is appropriate to add an overflow valve to the system providing the fresh working fluid.

**Fig.14** illustrates the integration between a two-piston internal combustion engine and an electric engine according to the invention. The integration of the electric engine is realized by a rigid connection of the rotor **60** to the 3D cam **20**, so that the 3D cam **20** and the rotor **60** rotate as a single body. A stator **61** of the electric engine is fixed to the housing **31** of the engine. The shown integration decreases the number of parts in comparison to the case, in which the engine and the electric engine are connected as two independent engines. Another advantage of such integration is the increase of efficiency due to the elimination of friction forces between the parts that fall off from the cam engine and electrical generator/motor as a result of their integration. Next advantage of the embedding of the electric engine in the built of the two-piston cam engine is its usage as a start motor, when the engine is working in a starting mode. In this way an additional start motor will not be necessary. The shown integration does not include input/output shaft and the respective gear set that connects it to the 3D cam **20**.

These components may be assembled in the body of the composite two-piston cam engine, when it is necessary to obtain not only electrical, but mechanical energy as well. The input/output shaft **30** and its gear set **28** and **29** are presented in **Fig.1**, **Fig.12** and **Fig.13**. A similar alternative of incorporation is when the rotor of the electric engine is directly connected to the input and/or output shaft of the cam engine.

**Fig.15** shows a two-piston internal combustion engine according to the invention, whose working cycle of which is split. The suction and compression phases of the engine working cycle are realized in cylinder **26a**, and the combustion process, expansion and discharge of the exhaust gases are realized in the other cylinder **26b**. It is obvious from the figure that the two cylinders **26a** and **26b** are connected between themselves by means of conduit **79**, through which the compressed working fluid is transferred from the compressing cylinder **26a** to the operating cylinder **26b**. So the compressed working fluid passes through the exhaust orifice **80** of the compressing cylinder **26a** and enters the operating cylinder **26b** through the input orifice **81** of combustion chamber **82** of cylinder **26b**. **Fig.15** shows variant with a split working cycle of the two-piston engine according to the invention, where the transmission of the compressed working fluid from cylinder **26a** to cylinder **26b** is indirectly realized. In this case, the compressed working fluid is initially collected in the intermediate pneumatic accumulator **83** and later used by the operating cylinder **26b**. The accumulation and the usage of the compressed working fluid are controlled by the two valves **84** and **85**, situated respectively at the entrance and the exit of the accumulator **83**. **Fig.15** also shows a decompression mechanism, described in **Fig.11a**, and an electromagnetic valve **86**, the function of which is to discharge cylinders **26a** and/or **26b** in the cases when they are not used temporarily. In this case, the compressing cylinder **26b** is serviced by the pair of one-way check valves **87**.

**Fig.16**, **Fig.17a/b** and **Fig.18a/b** show different law of the followers.

Although the description above contains many specifics, these should not be construed as limiting the scope of the invention but as merely providing illustrations of some of the presently preferred embodiments of this invention. Thus, the scope of this invention should be determined by the appended claims and their legal equivalents.

## PATENT CLAIMS

1. The cam engine comprising a housing (22, 31, and 21), at least one cylinder (26), at least one piston (25) moving in the cylinder (26), at least one of which pistons (25) is a working piston, cylindrical tubular 3D cam (20) with cam groove  
5 along the internal cylindrical surface, which groove is made so that the line forming its cross-section is a straight or concave line, the low end of which is located towards the axis of 3D cam (20), and at least two asynchronously moving followers (1a, 1b), positioned against each other, and each follower comprises at least two arms (37) standing at an angle to each other and having main rollers (3) bearing at the free ends of  
10 the corresponding arm (37), and each follower also comprises additional rollers (5) that can move along the axes (17) of the corresponding main rollers (3), so that each main and additional roller (3, 5) contacts the cam groove, **characterized by the fact that**
- the additional rollers (5) have the possibility to rotate in relation to the axes (18) of the main rollers (3), so that they are able to self-adjust in order to achieve rolling  
15 without sliding;
  - in addition, it comprises stoppers (9 or 43) to limit the movement (17) of the additional rollers (5) along the axes of the main rollers (3);
  - the cam groove has a periodically changing cross-section, depending on the number of the convex and concave sections of the profile of the 3D cam (20).
- 20           2. A cam engine according to Claim 1, **characterized by the fact that** the cam groove is made so that at the top and bottom dead centers (88, 89) the distance between the cam profiles (15a, 15b) of the groove of the 3D cam (20) in the cross-section is the greatest, and the distance in the cross-section between the cam profiles (15a, 15b) of the groove of the 3D cam (20) between the two dead centers (88,  
25 89) is the smallest, so that the movement (17) of the additional rollers (5) along the axes of the main rollers (3) to be maximum reduced.
3. The cam engine according to Claim 1, **characterized by the fact that** the cam groove is made so that along the lines of rolling of the additional rollers (5) there are narrower grooves (32) having the greatest depth at the top and bottom dead  
30 centers (88, 89), and their depth between the two dead centers (88, 89) is minimum, so that the movement (17) of the additional rollers (5) along the axes of the main rollers (3) to be maximum reduced.

4. Cam engine according to Claim 1, **characterized by the fact** that the cam groove is made so that along the lines of rolling of the additional rollers (5) there are narrower convex paths (90) having the greatest height between the two dead centers (88, 89), and their height at top and bottom dead centers (88, 89) is minimum, so that the movement (17) of the additional rollers (5) along the axes of the main rollers (3) to be maximum reduced.

5. Cam engine according to Claim 1, **characterized by the fact** that at the free end of each arm (37) of the follower (1a, 1b) at least two main rollers (3a, 3b) are mounted, bearing to the respective arm (37) of the follower (1a, 1b) independently.

6. Cam engine according to Claim 1, **characterized by the fact** that the 3D cam (20) is composite and comprises two coaxial bushings (16a, 16b), each having a corrugated cam profile (15a, 15b) on one side, and the cam bushings (16a, 16b) are situated at a distance one from another with their corrugated ends facing each other so, that the convex parts of the cam profile of one of the bushings are opposing the concavities of the cam profile of the other bushing, also comprising at least two guiding columns (27) for the reciprocating linear motion of each piston (25), which columns (27) are parallel and at an equal distance from the axis of the 3D cam (20).

7. Cam engine according to Claim 1, **characterized by the fact** that the corrugated cam profiles (15a, 15b) are made so that the curve of the law of motion of the followers (1a, 1b) in function of the angle of rotation of the 3D cam (20) is:

- formed by consecutively alternating ascending and descending sections, as a result of which equal number of convexities and concavities (93, 94) are obtained, the total number of which is equal to or multiple by the sum of the number of the arms (37) of the followers (1a, 1b);

- continuous at least up to its second derivative within one complete rotation of the cam at  $360^{\circ}$ , which is valid for both end points (95) inclusively;

- symmetrical for each two adjacent ascending and descending sections (91, 92) toward a line (96) passing through their point of junction (97, 95) and the line (96) is perpendicular to the tangent (98) to the curve (33) at this point.

8. Cam engine according to Claim 7, **characterized by the fact** that each ascending and descending section (91, 92) of the curve (33) has one

maximum and one minimum value (99 and 100) of its second derivative, which do not coincide with the end points (95, 97) of the respective section (91 or 92).

5           **9.** Cam engine according to Claim 8, **characterized by the fact that** the value (101) of the second derivative of the curve (33) is equal to zero in point of junction (97, 95) of each two adjacent sections.

**10.** Cam engine according to Claim 9, **characterized by the fact that** identical straight sections (102) are included in the area of the points (95, 97) of junction of the curve (33).

10           **11.** Cam engine according to Claim 1, **characterized with the fact that** it also comprises an electric rotor (60) rigidly connected to the 3D cam (20) and a stator (61) rigidly connected to the housing (31) of the engine so that a combination between a piston engine and an electric engine is accomplished.

15           **12.** Cam engine according to Claim 1, **characterized by the fact that** it also comprises an input and/or output shaft (30), electric rotor rigidly connected to the input and/or output shaft (30), and a stator (61) rigidly connected to the housing (31) so that a combination between a piston engine and an electrical engine to be accomplished.

**13.** Cam engine according to Claim 1, **characterized by the fact that** it also comprises means for delivery and discharge of working fluid (49a, 49b).

20           **14.** Cam engine according to Claim 1, **characterized by the fact that** at least the main and additional rollers (3, 5) are external bearing rings of composite bearings (76), including multiple bearing rings (63) with different diameters, situated concentrically to each other and the connection between them is sliding or through rolling bodies (64).

25           **15.** Compressor, **characterized by the fact that** it includes at least one cam engine according to any of claims from 1 to 14.

**16.** Pump, **characterized by the fact that** it includes at least one cam engine according to any of claims from 1 to 14.

30           **17.** Motor, **characterized by the fact that** it includes at least one cam engine according to any of claims from 1 to 13 and it also includes at least one kinematic chain having a 2D cam (52) connected to the 3D cam (20); at least one intake or exhaust valve (49a, 49b) located in a cylinder head (57); a rocker (48) connected by

means of cylindrical joint (56) to a static component of the motor, besides the rocker (48) has one arm (50), through which it is in contact with the 2D cam (52), and at least one other arm (53), each contacting an intake or exhaust valve (49a, 49b).

5           **18.** Motor according to Claim 17, **characterized by the fact that it**  
also comprises a supercharging mechanism having at least one valve (39) for opening  
the housing of the motor to let the atmosphere air in when the pistons (25) are moving  
apart and located on the housing, and at least one 2D cam (45) for managing the  
movement of the valve (39), which 2D cam (45) is mounted to the 3D cam (20).

10           **19.** Motor according to Claim 17, **characterized by the fact that it**  
also comprises a supercharging mechanism, comprising at least one diaphragm pump  
(46) located on the housing of the motor for supercharging the atmosphere air in the  
intake manifold (38) of the motor, and at least one 2D cam (45) for actuating the motion  
of the diaphragm pump (46), which 2D cam (45) is fixed to the 3D cam (20).

15           **20.** Motor according to Claim 17 **characterized by the fact that it**  
comprises one operating cylinder (26b) functioning as a heat engine, and one opposed  
cylinder (26a) functioning as a compressor or a pump.

20           **21.** Motor according to Claim 20 **characterized by the fact that the**  
opposed cylinder (26a) is a cylinder of a compressor and also having a pneumatic  
accumulator (83) for feeding the operating cylinder (26b) with at least a part of the  
compressed air from the opposed cylinder (26a) and for keeping the air and/or for  
preparing the fuel-air mixture for the next working cycle of the operating cylinder (26b).

1/15

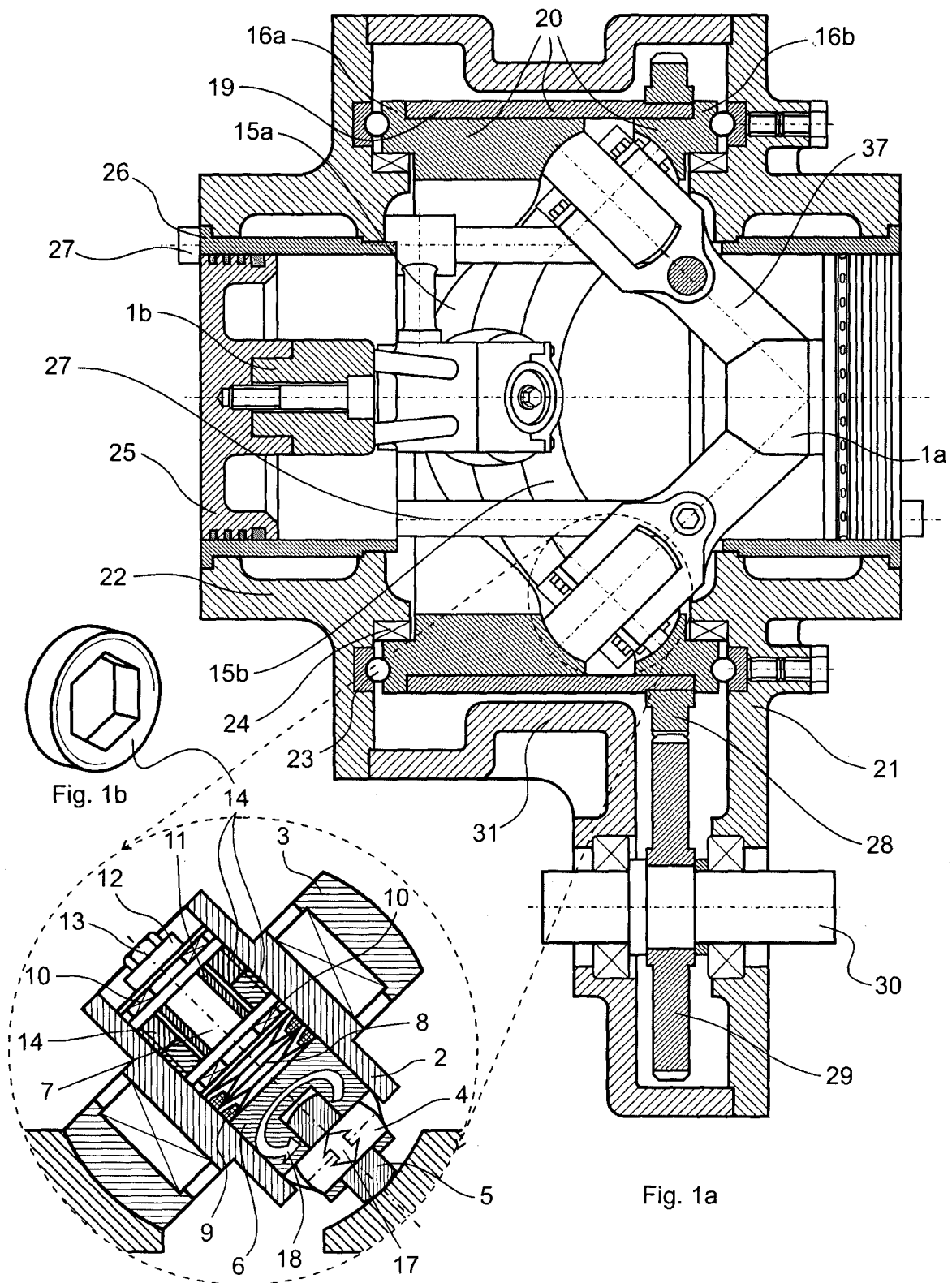

Fig. 1b

Fig. 1a

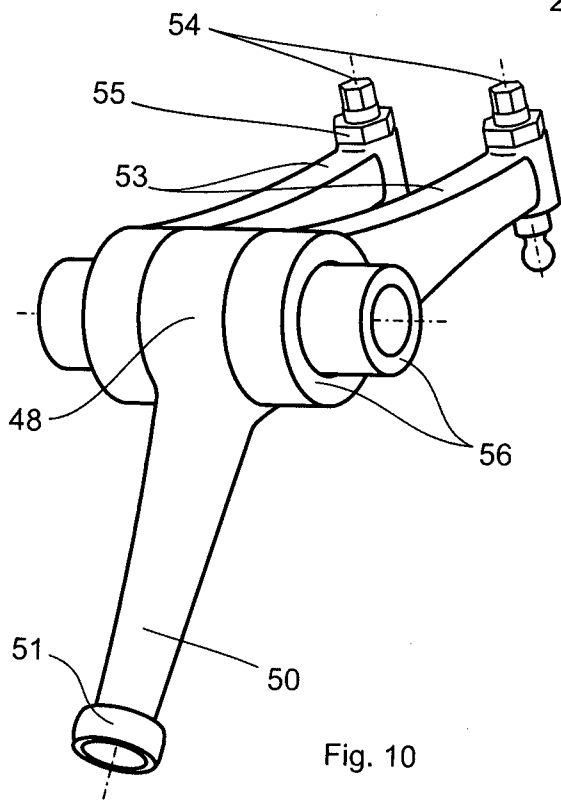

Fig. 10

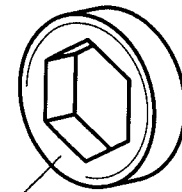

Fig. 1b

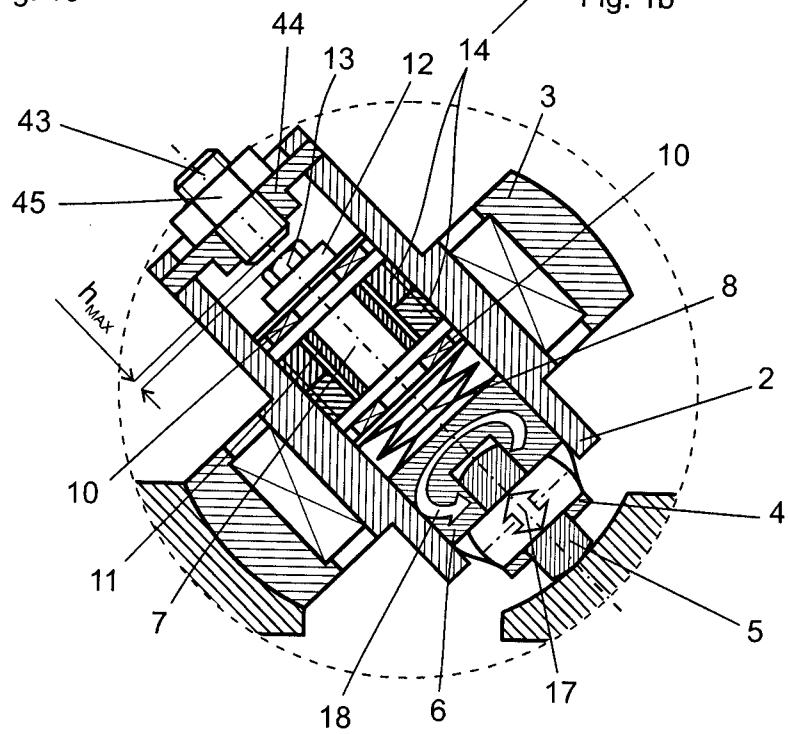
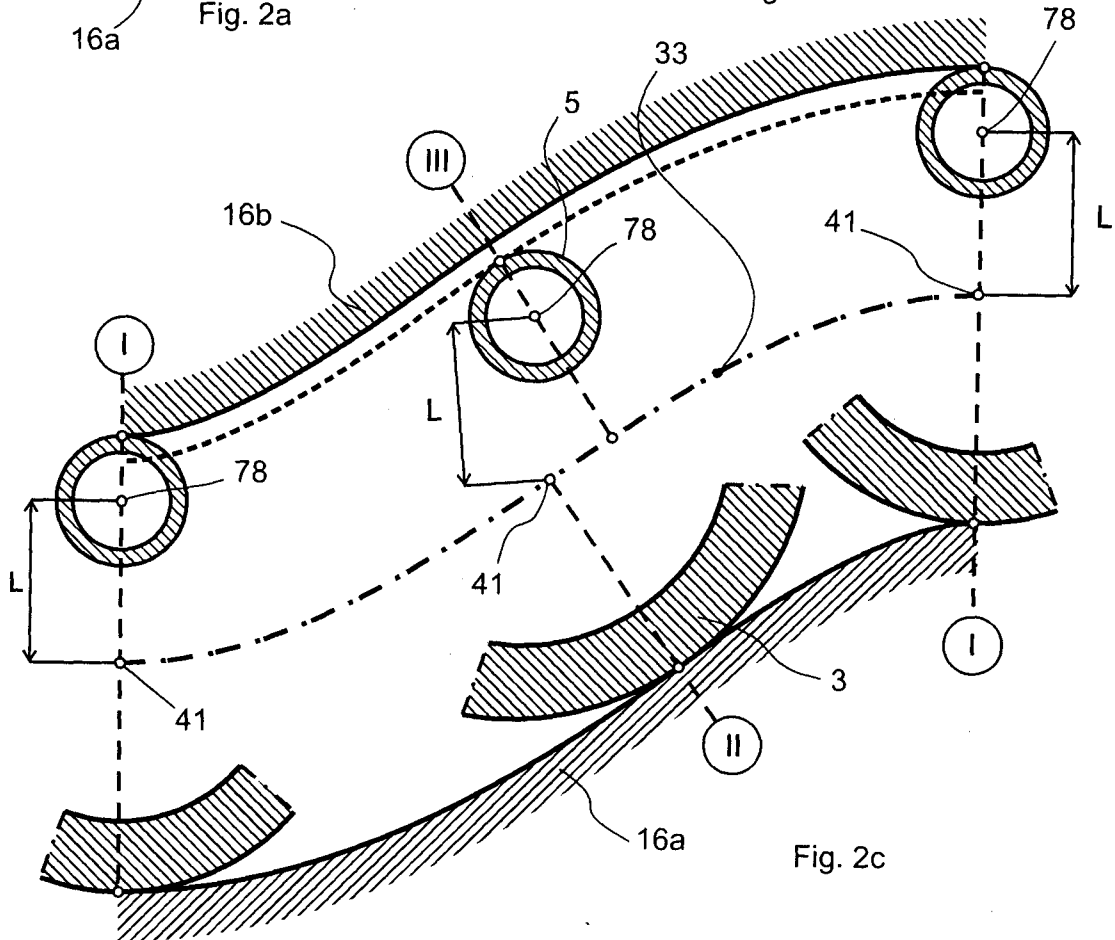
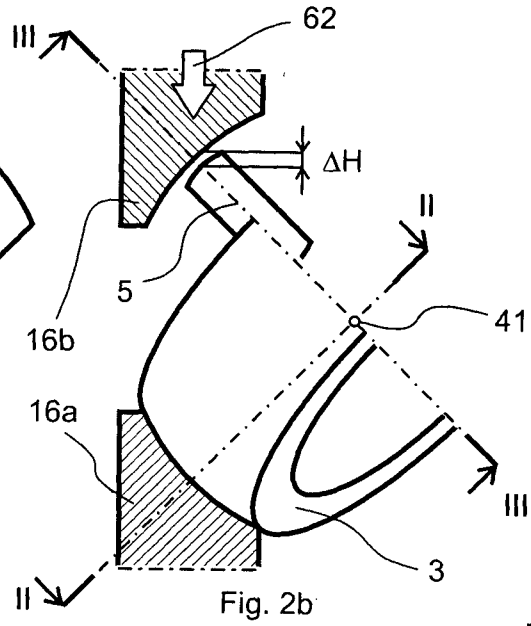
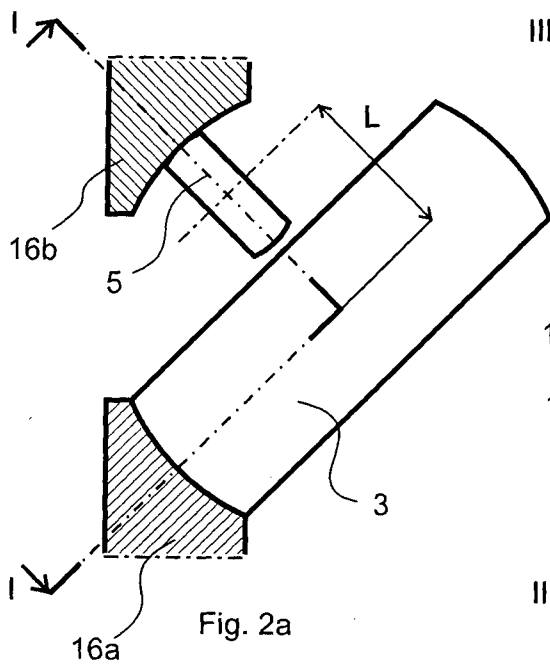
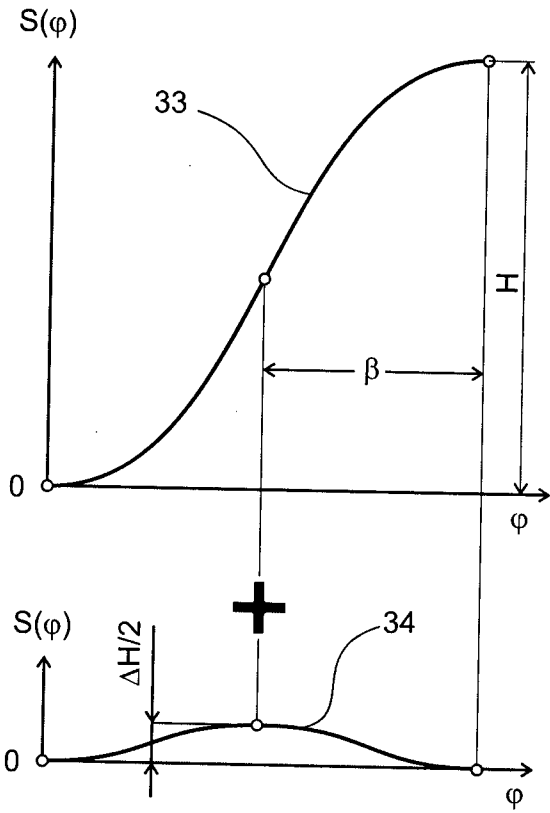

Fig. 1c

3/15





||

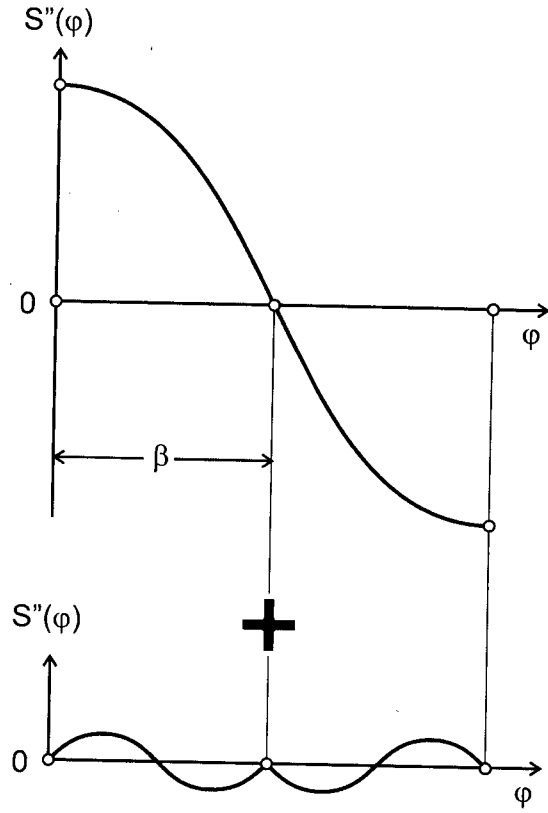

||

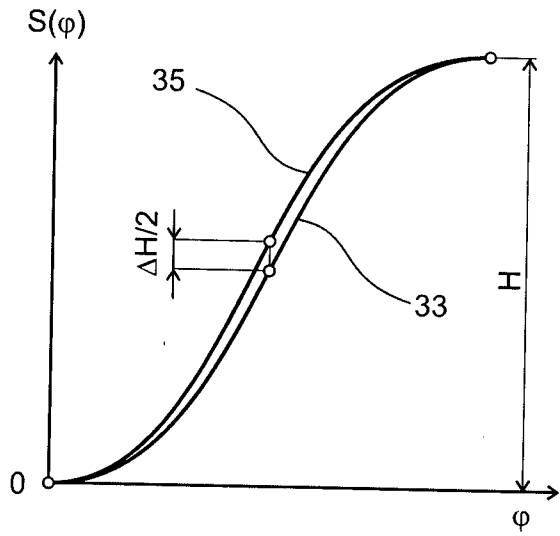

Fig. 3a

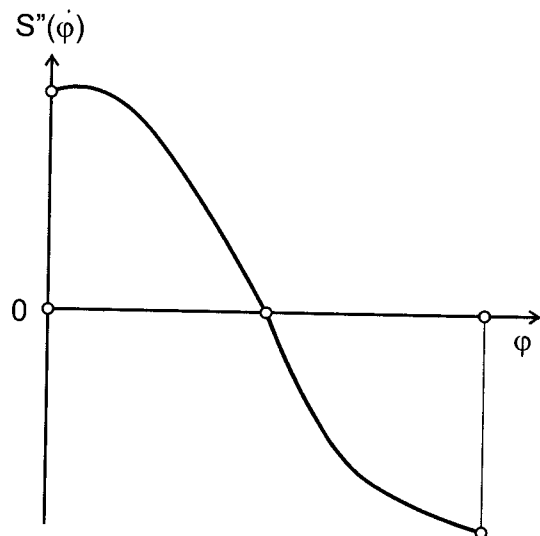
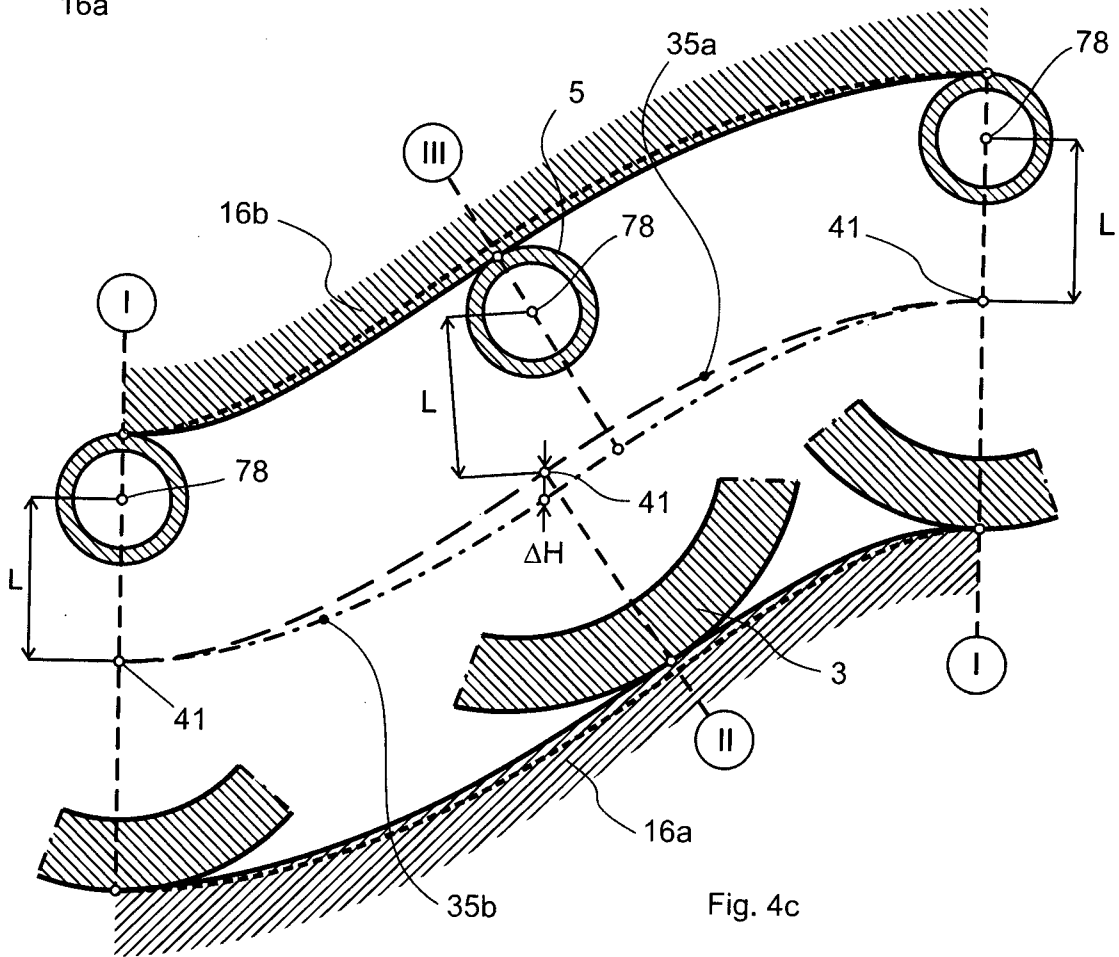
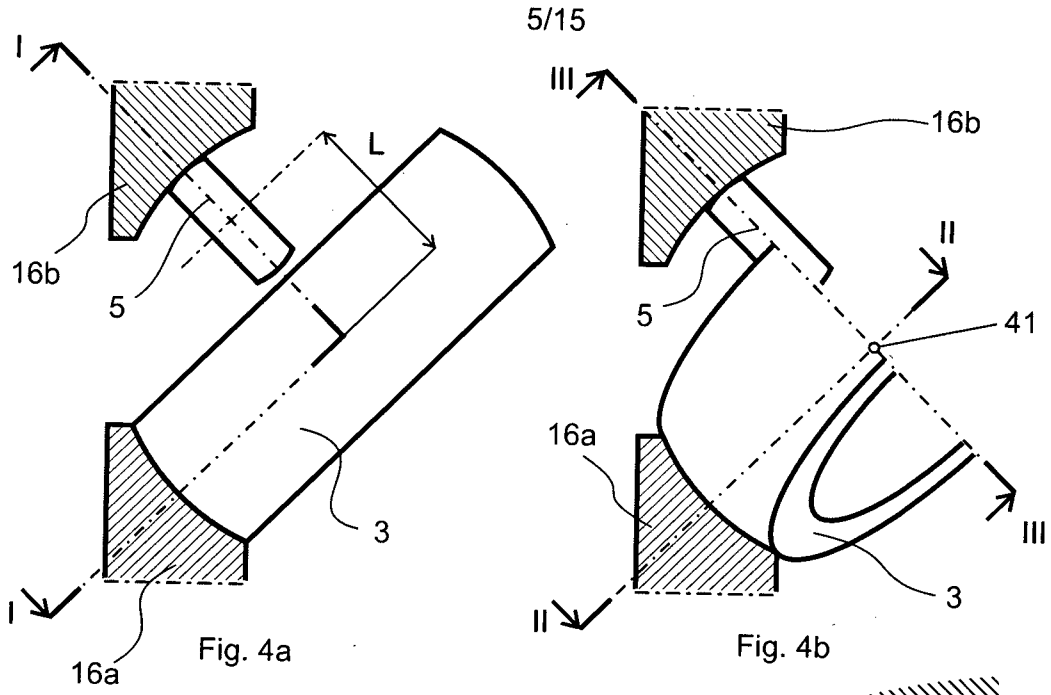

Fig. 3b



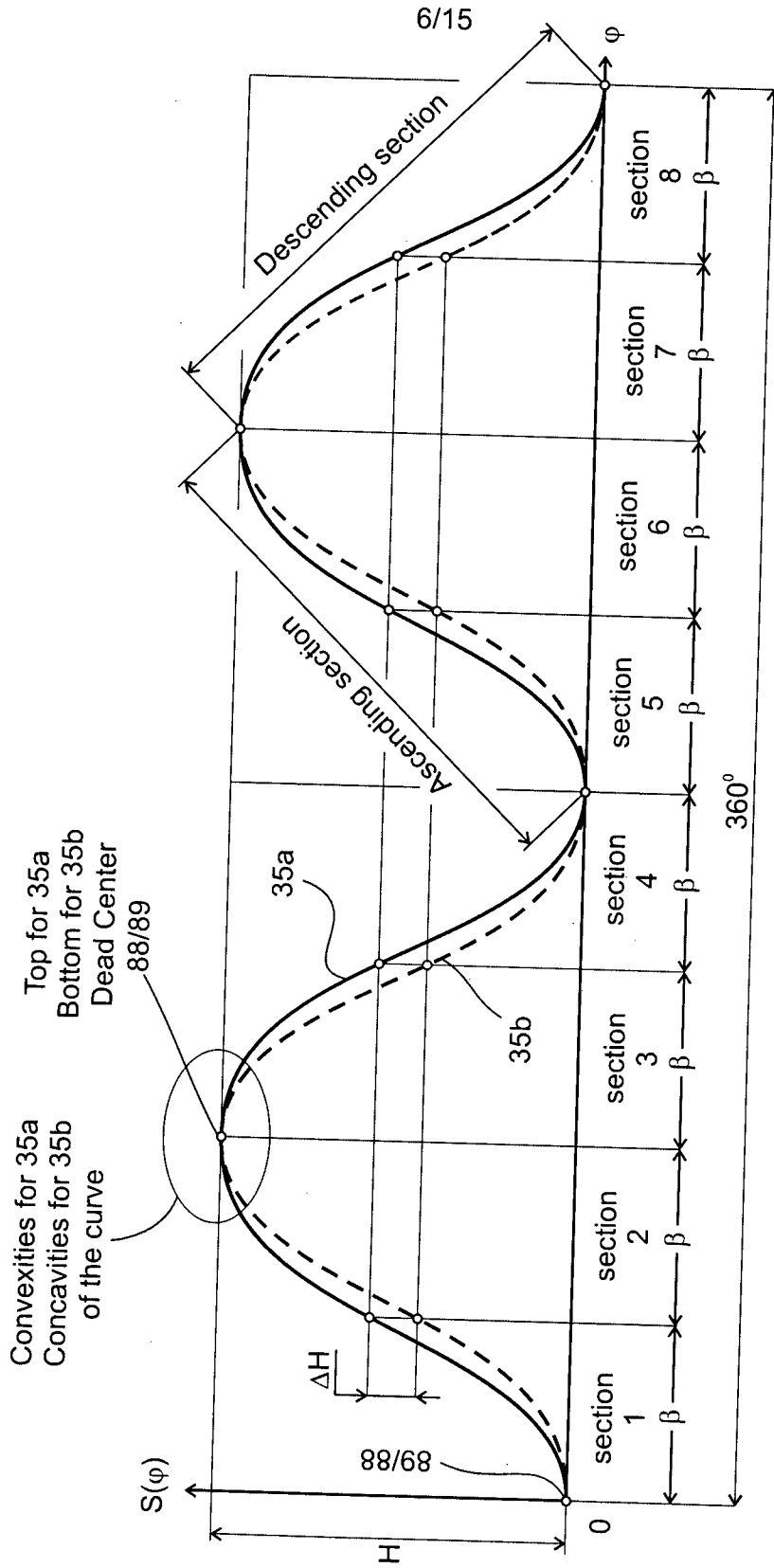

Fig. 5

7/15

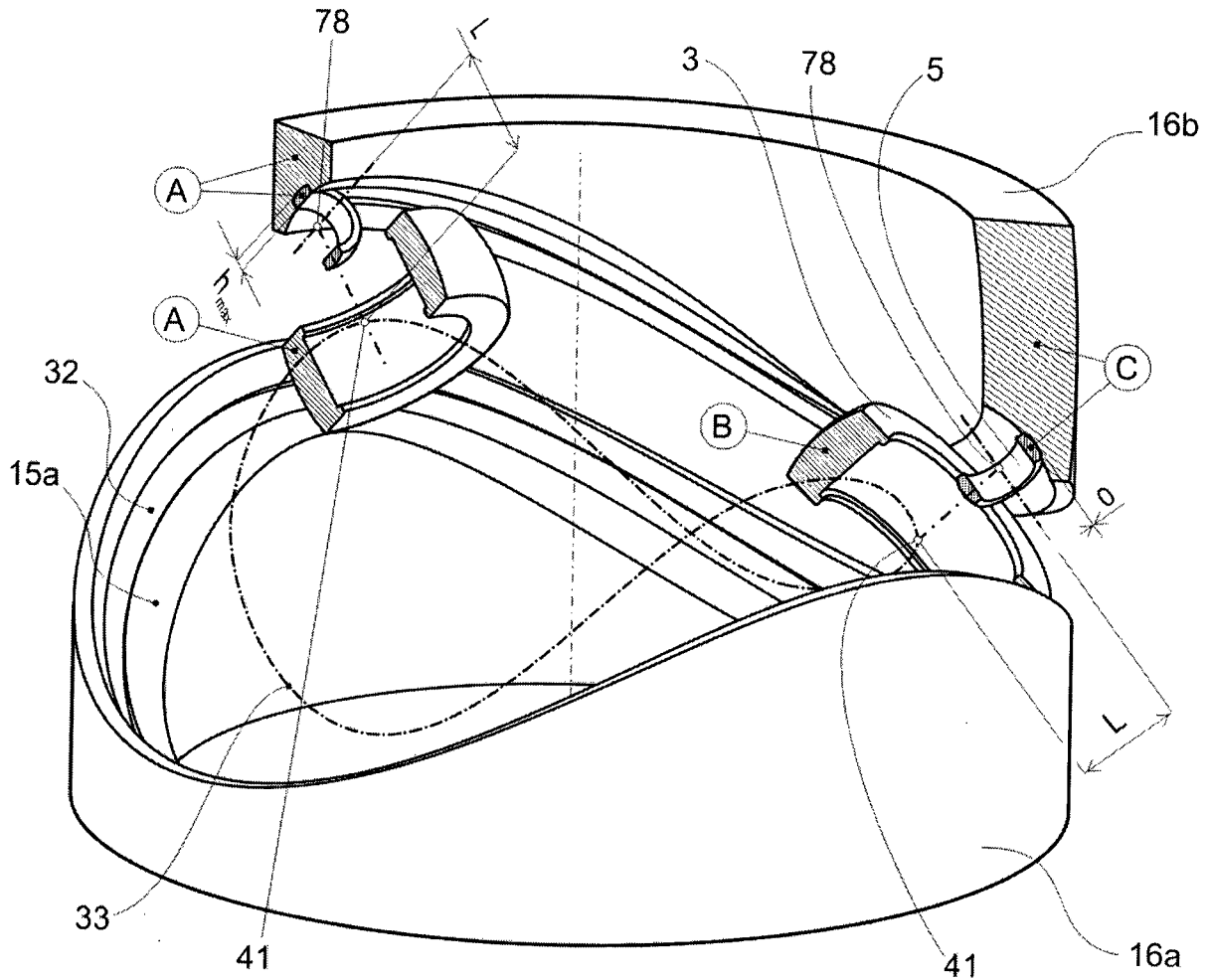

Fig. 6a

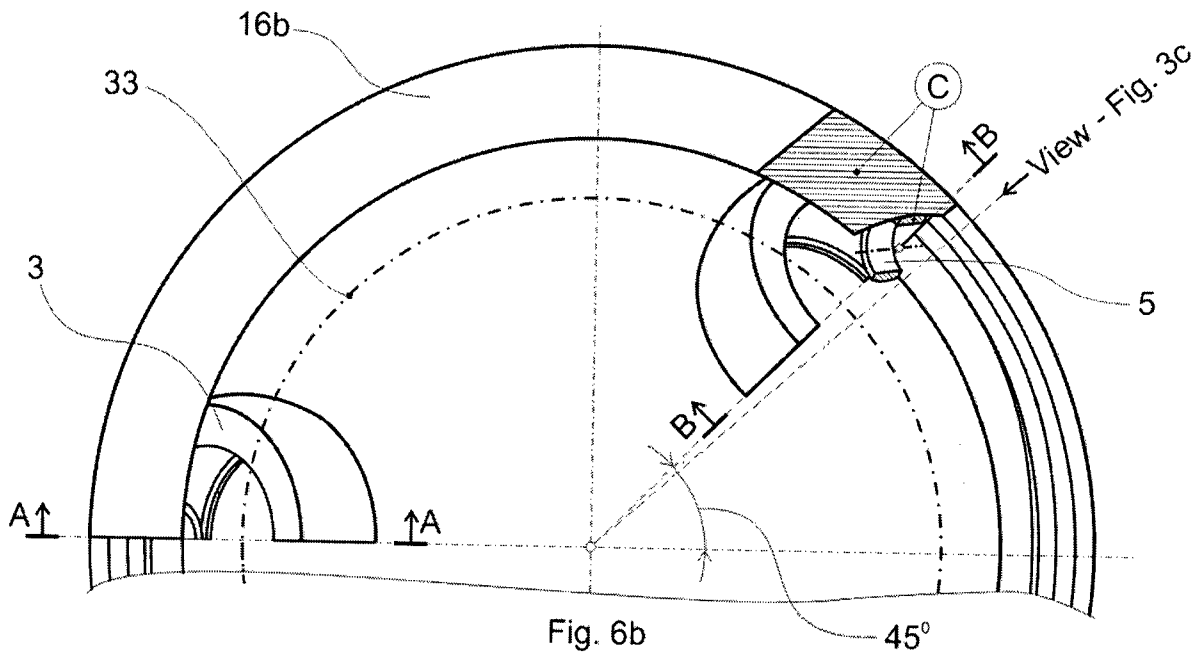

Fig. 6b

8/15

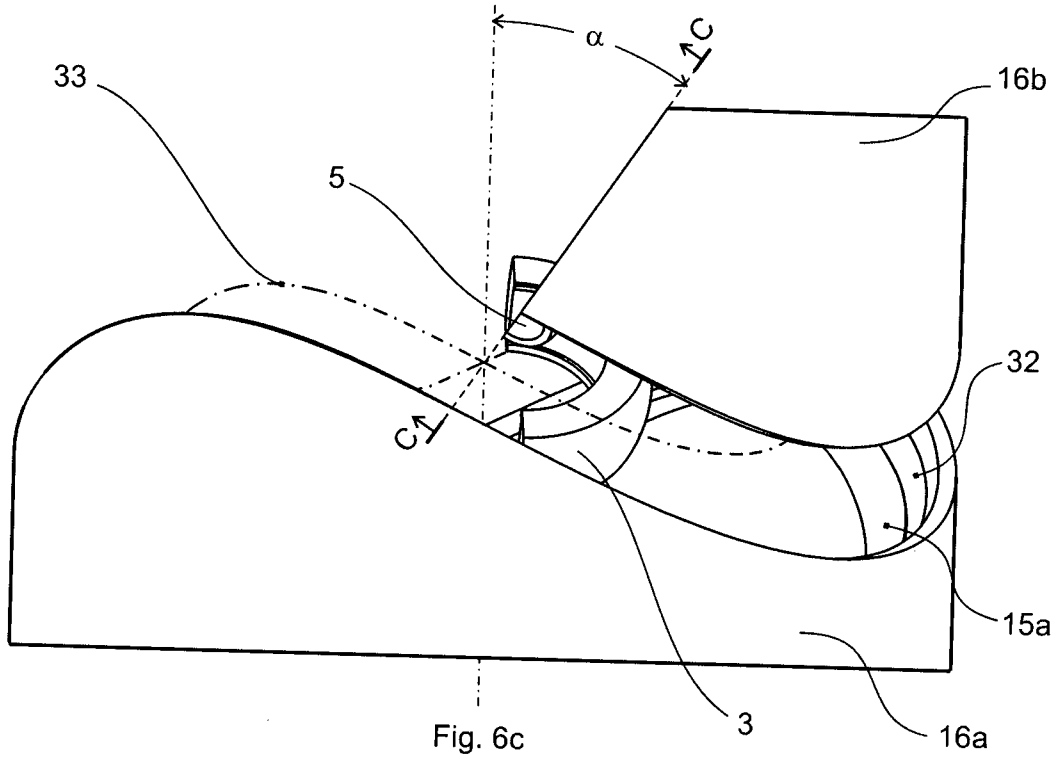

Fig. 6c

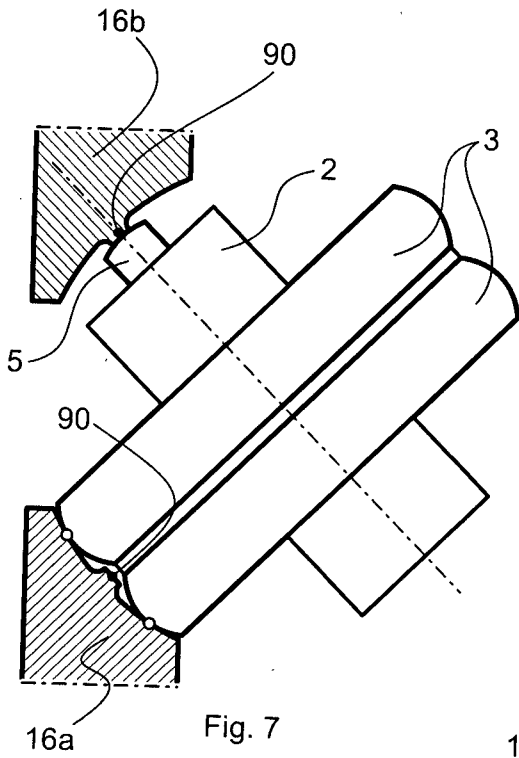

Fig. 7

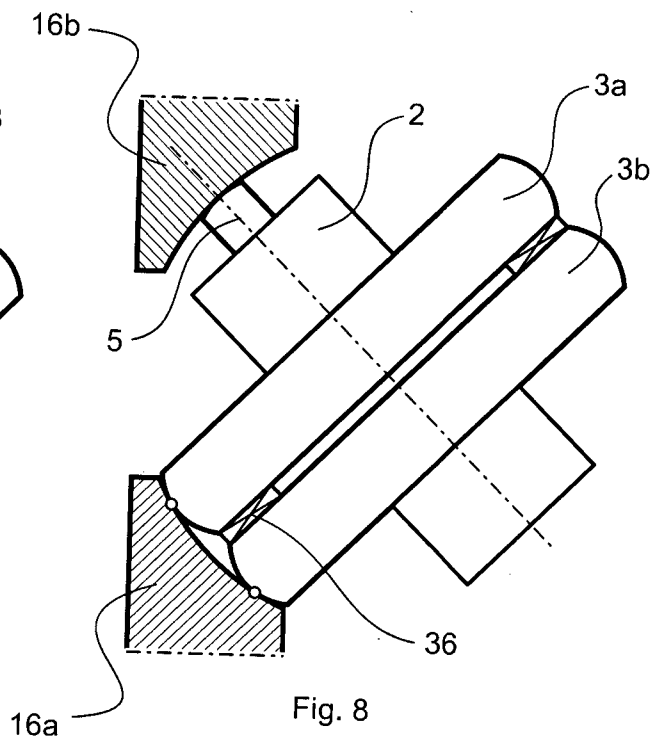
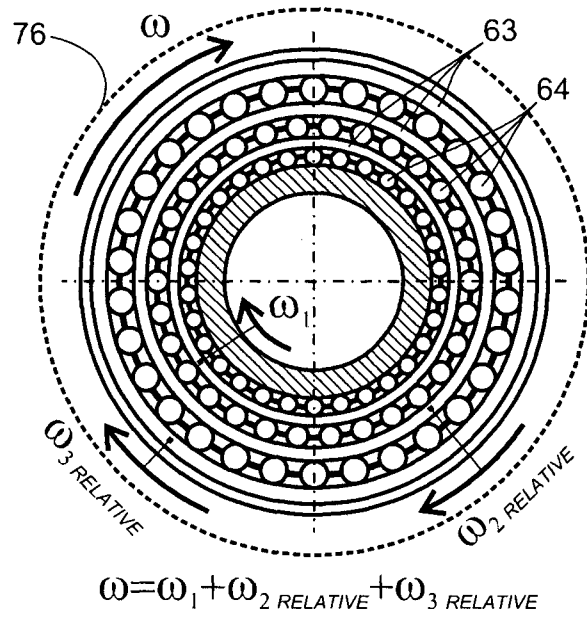
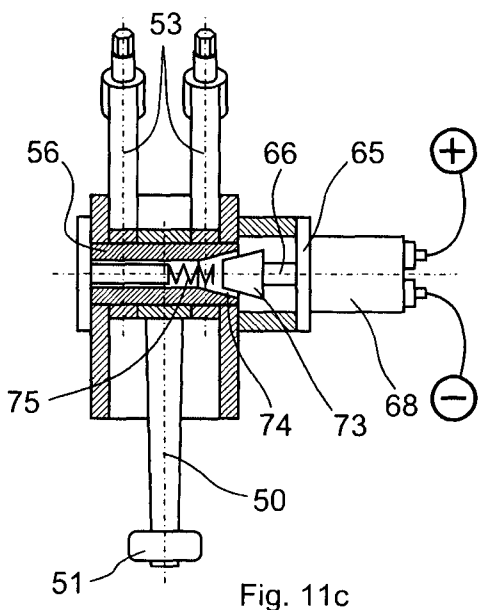
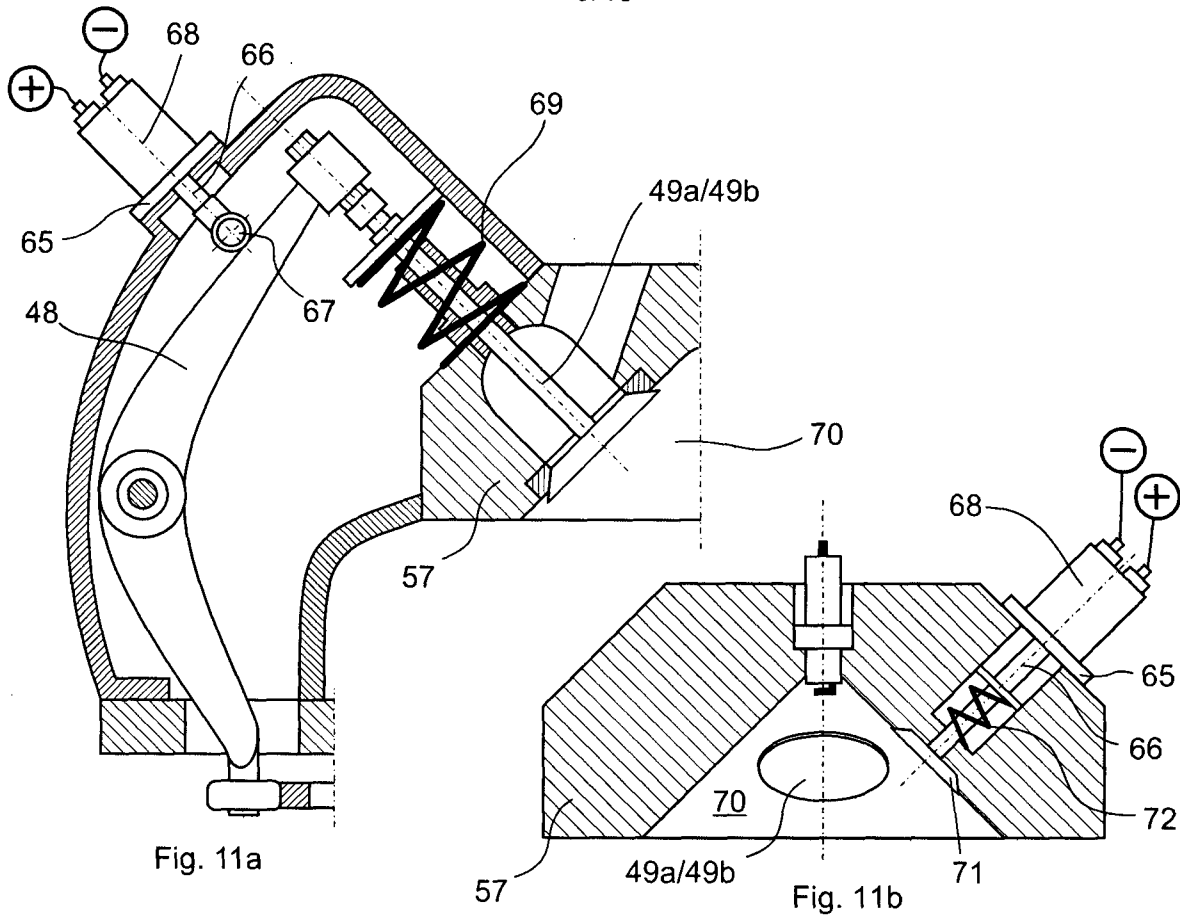

Fig. 8

9/15



$$\omega = \omega_1 + \omega_{2 \text{ RELATIVE}} + \omega_{3 \text{ RELATIVE}}$$

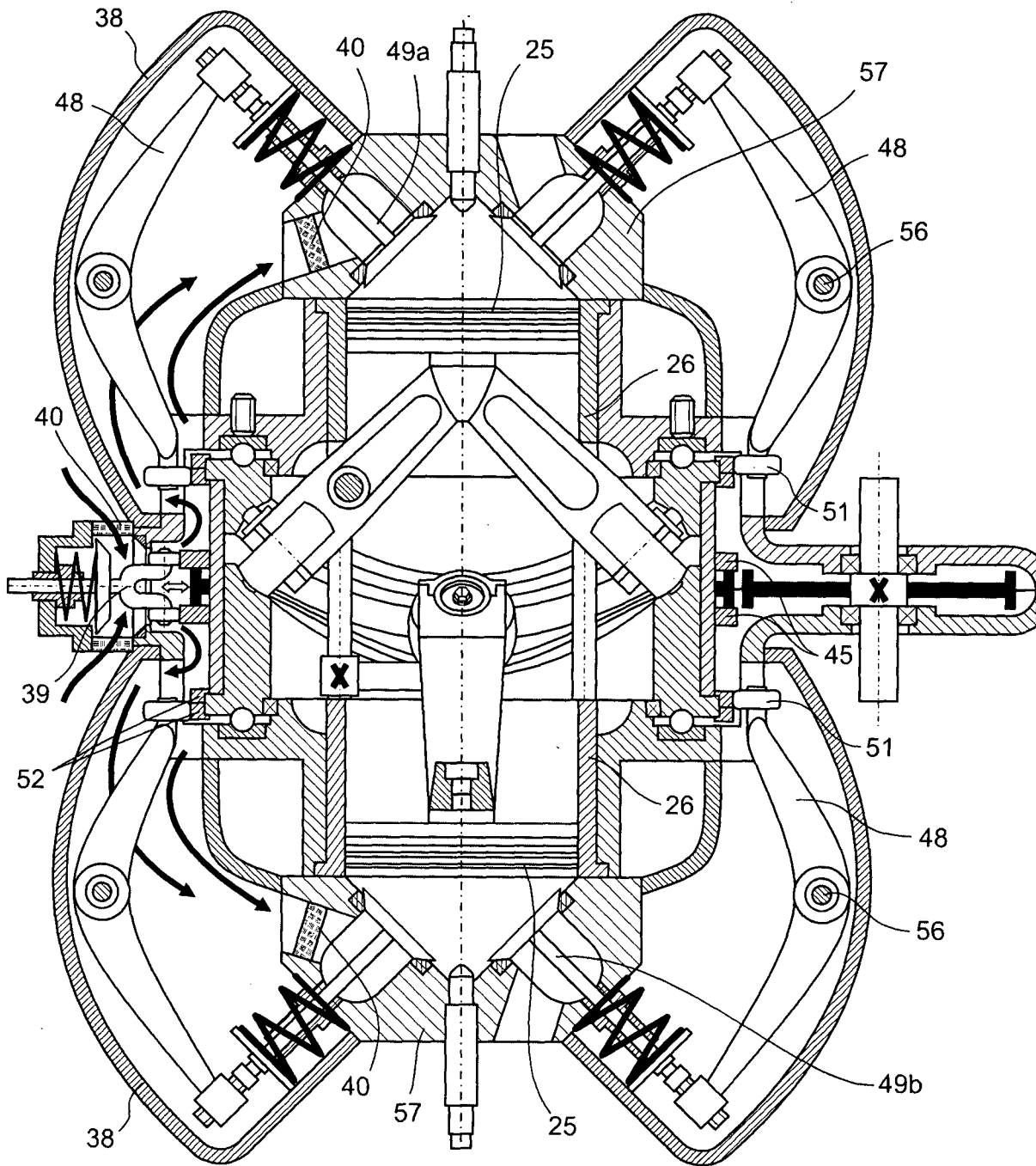

Fig. 12

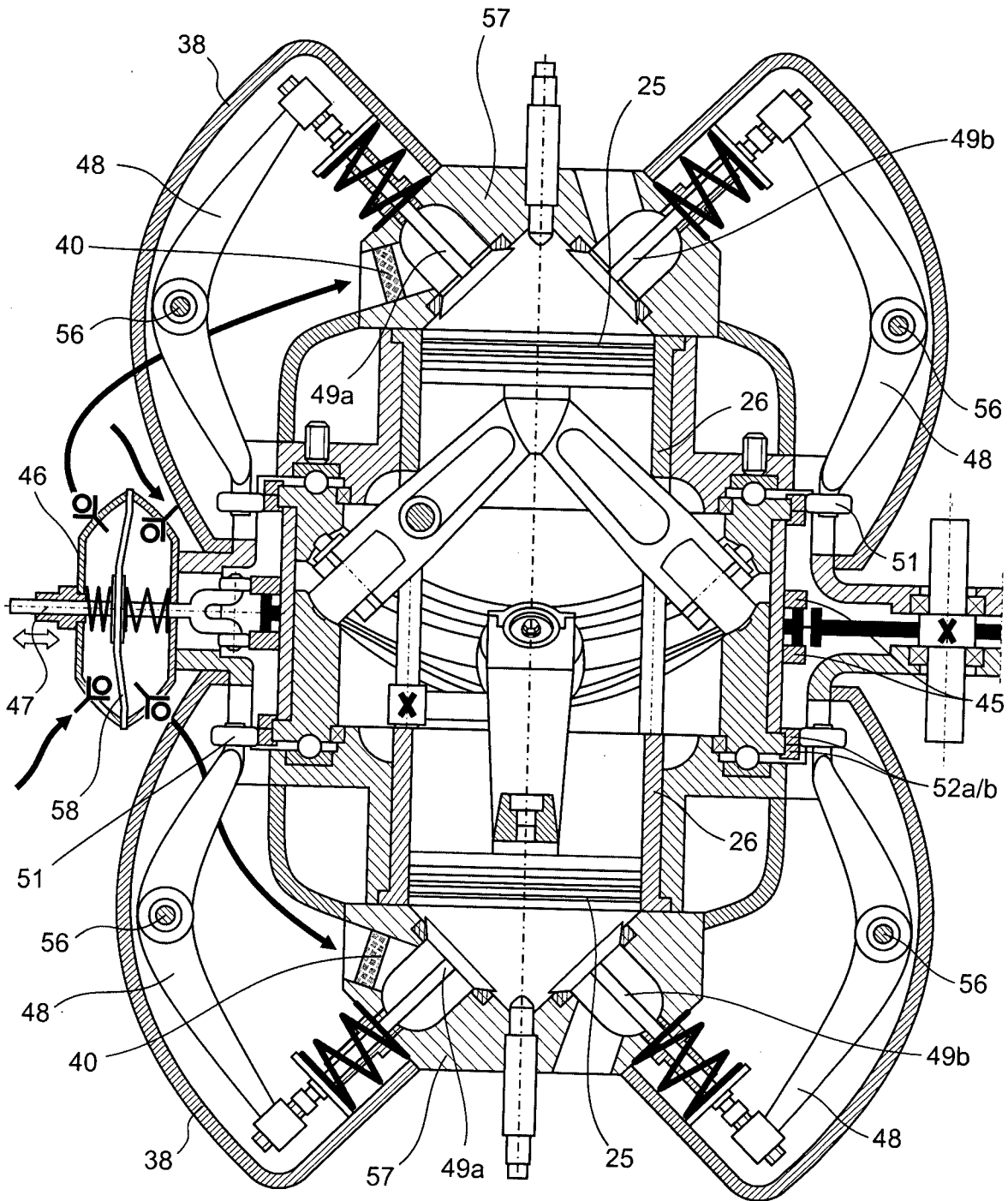

Fig. 13

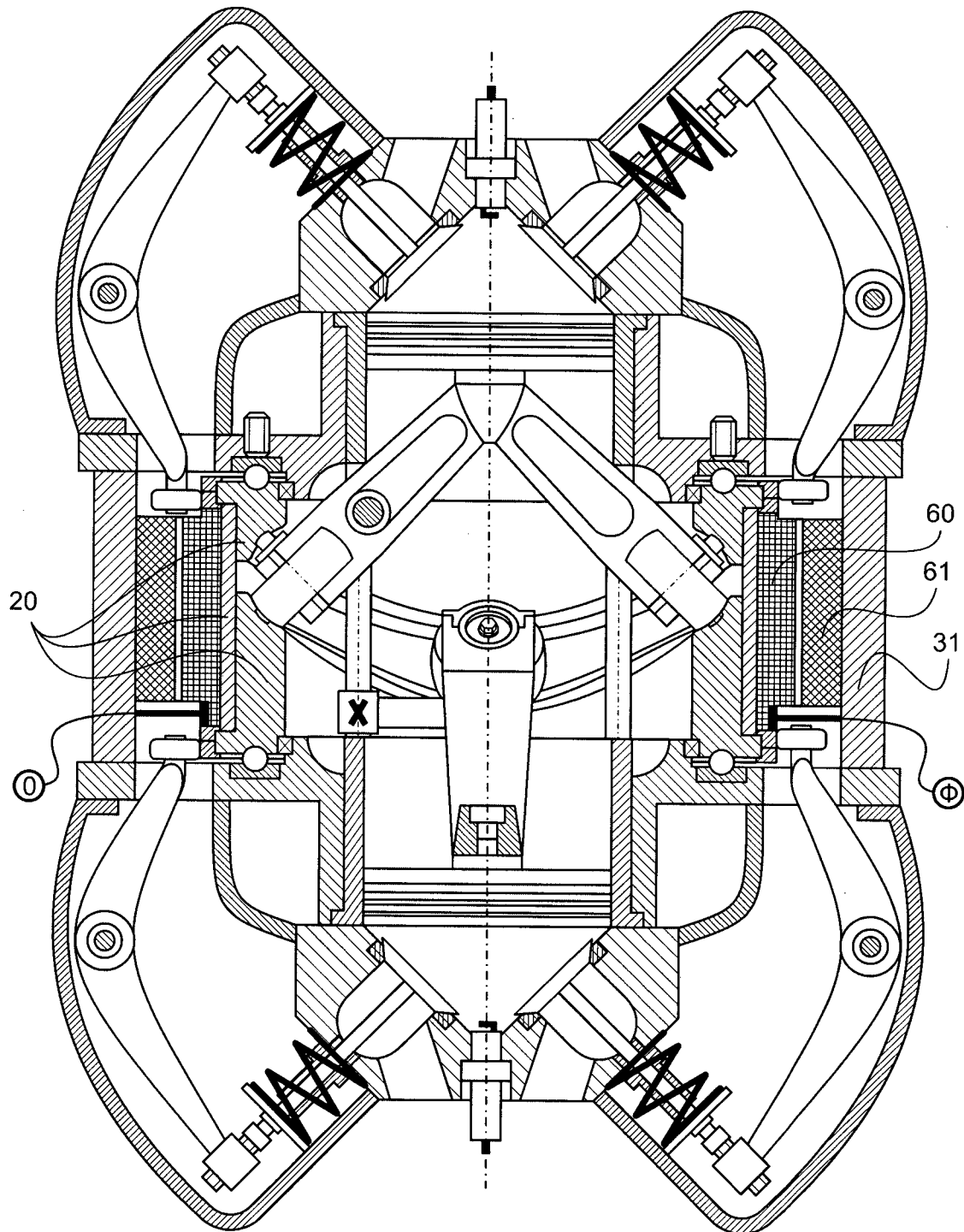

Fig. 14

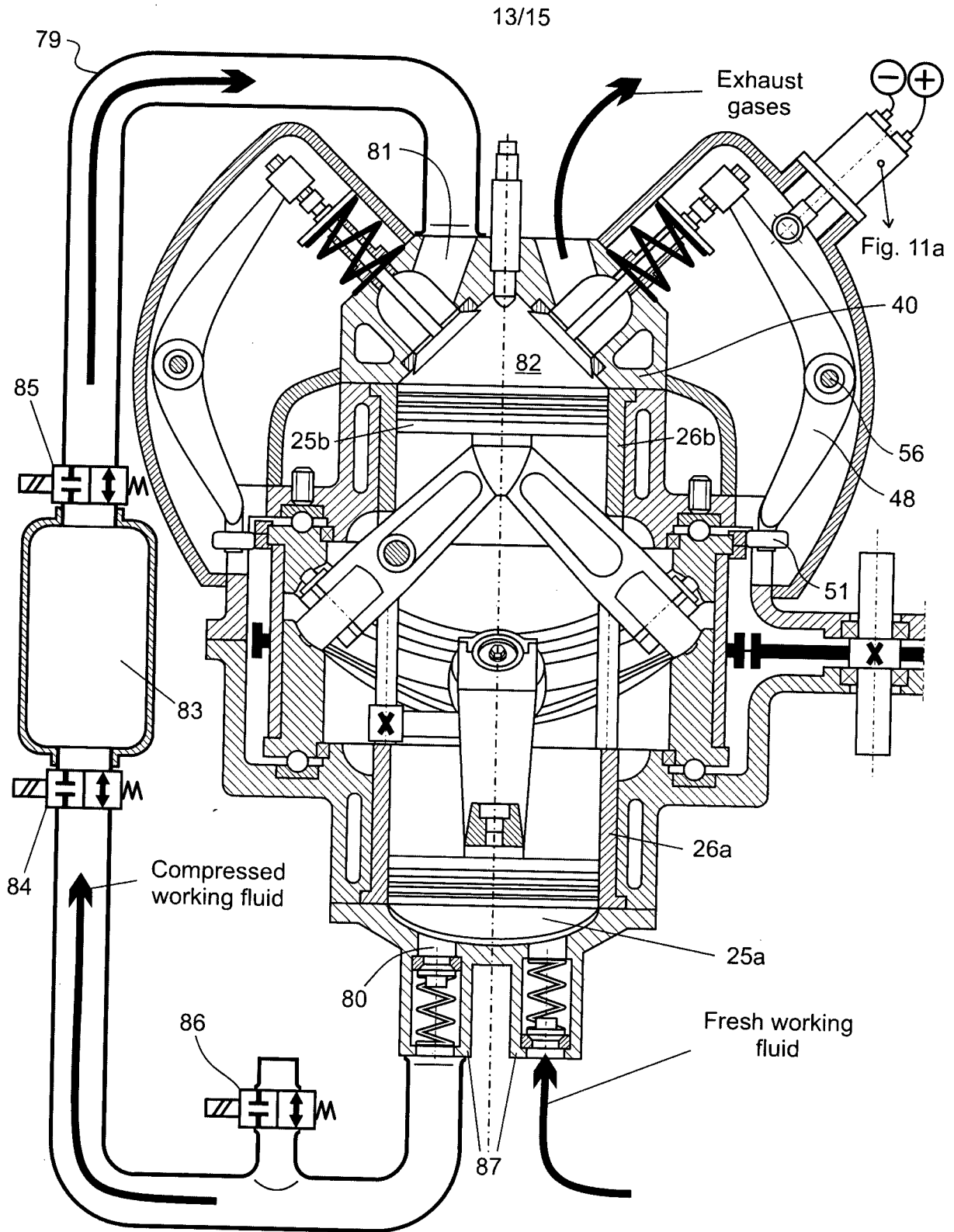

Fig. 15

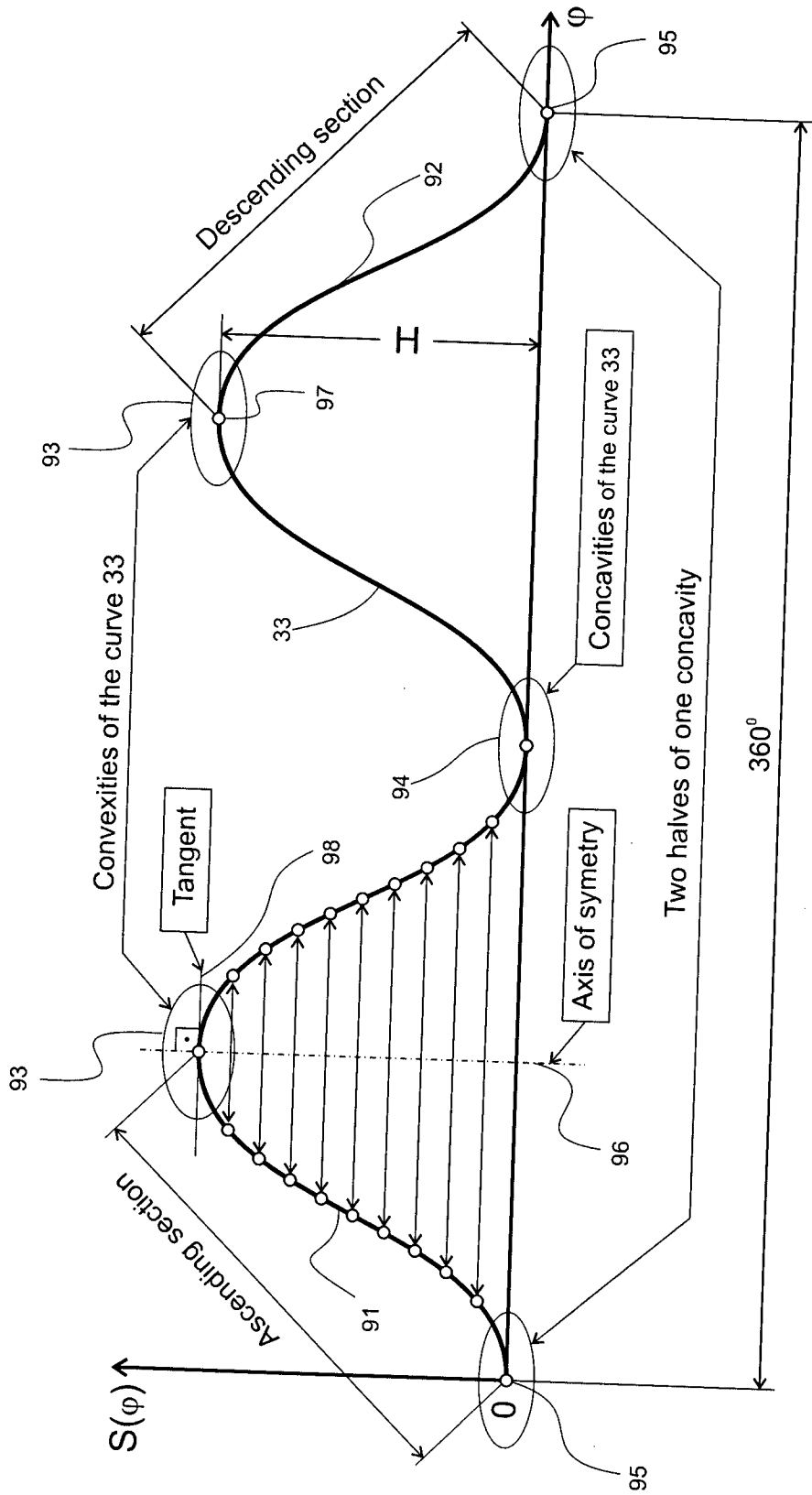

Fig. 16

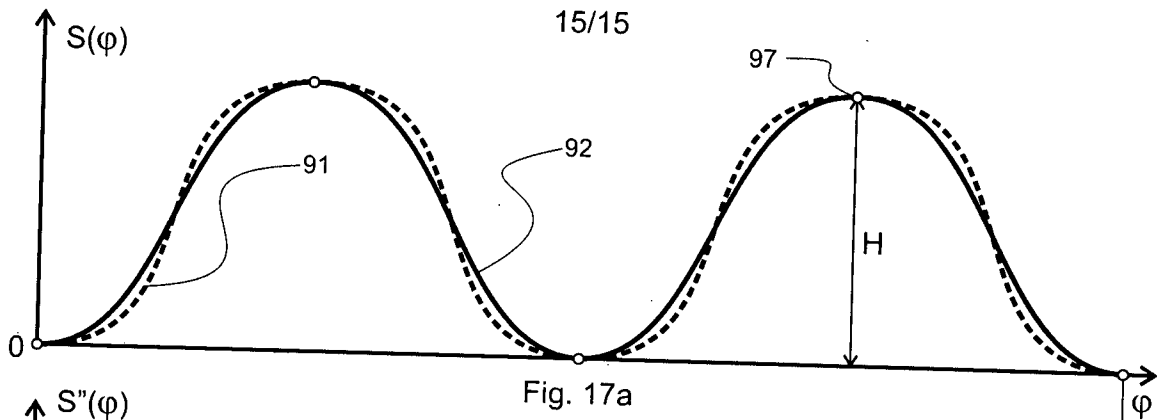

Fig. 17a

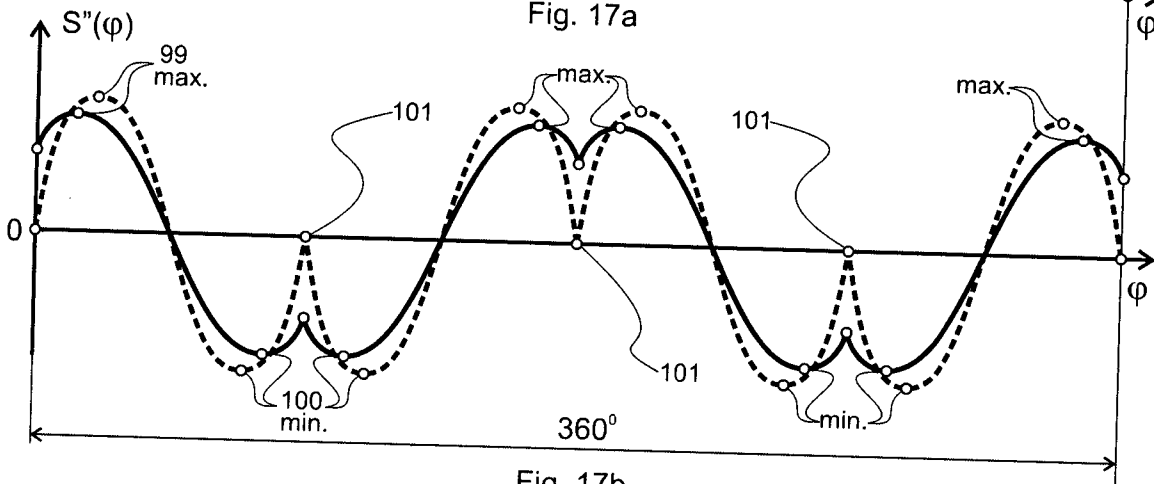

Fig. 17b

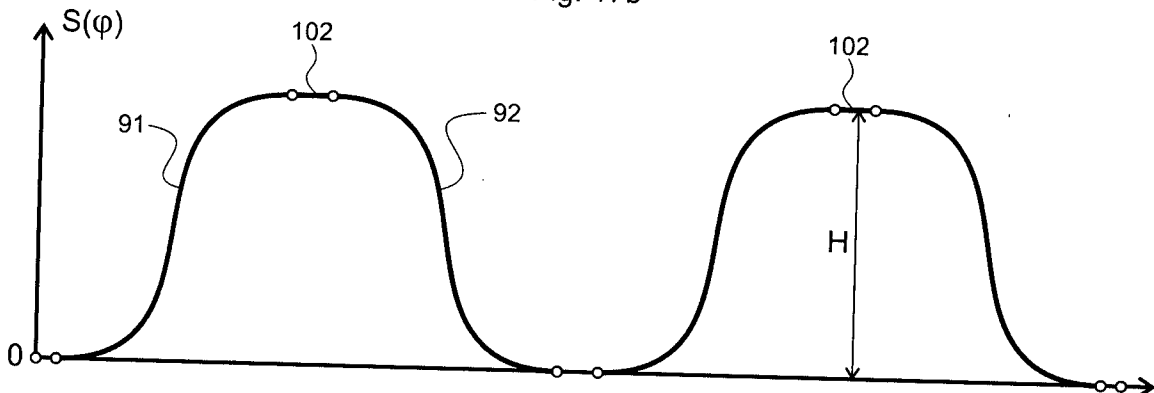

Fig. 18a

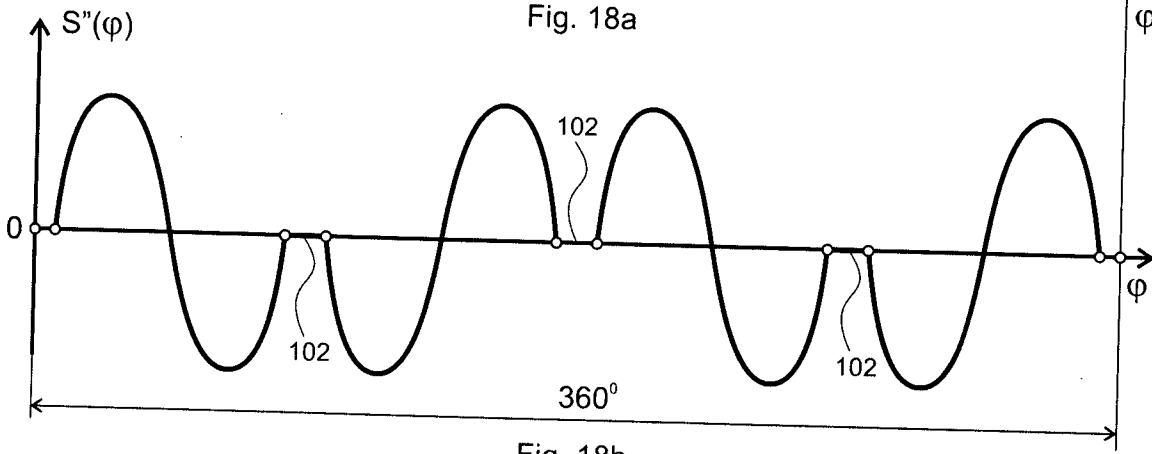

Fig. 18b