

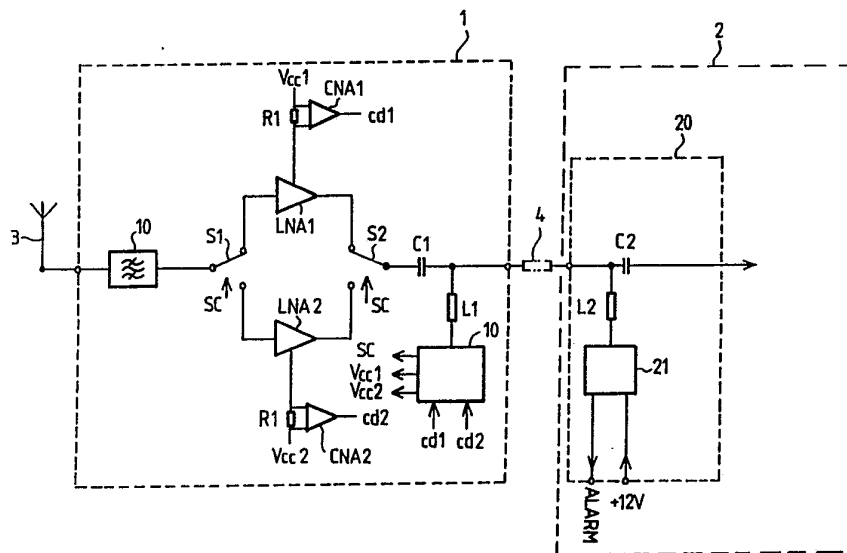

INTERNATIONAL APPLICATION PUBLISHED UNDER THE PATENT COOPERATION TREATY (PCT)

<p>(51) International Patent Classification ⁵ : H03F 3/68, H04B 1/74</p>	<p>A1</p>	<p>(11) International Publication Number: WO 91/19348 (43) International Publication Date: 12 December 1991 (12.12.91)</p>
<p>(21) International Application Number: PCT/FI91/00180 (22) International Filing Date: 6 June 1991 (06.06.91) (30) Priority data: 902884 8 June 1990 (08.06.90) FI (71) Applicant: TELENOKIA OY [FI/FI]; P.O. Box 33, SF-02601 Espoo (FI). (72) Inventor: SAVUSALO, Juha ; Valtatie 73 A 16, SF-90500 Oulu (FI). (74) Agent: OY KOLSTER AB; Stora Robertsgatan 23, P.O. Box 148, SF-00121 Helsinki (FI).</p>		<p>(81) Designated States: AT (European patent), AU, BE (European patent), CH (European patent), DE (European patent), DK (European patent), ES (European patent), FR (European patent), GB, GB (European patent), GR (European patent), IT (European patent), LU (European patent), NL (European patent), NO, SE (European patent). Published <i>With international search report.</i></p>

(54) Title: APPARATUS FOR DETECTING FAILURE OF AN ANTENNA AMPLIFIER UNIT WITH A HOT STANDBY REDUNDANCY



(57) Abstract

The invention relates to an apparatus for detecting failure of an antenna amplifier unit (1), replicated on the hot standby principle, in a receiving unit (2) positioned apart from an antenna (3), the receiving unit comprising power supply means (20) for supplying operating voltage to the antenna amplifier unit through an antenna cable (4). To transmit information on the failure of the amplifier to the receiving unit, the apparatus of the invention is characterized in that the antenna amplifier unit (1) comprises control means (10) responsive to a failure of an amplifier for disconnecting an amplifier (LNA1, LNA2) from the supply of operating voltage, and that the power supply means (20) are capable of detecting a change in power consumption resulting from the disconnection of the amplifier from the supply of operating voltage and thereby the failure of the amplifier (LNA1, LNA2).

FOR THE PURPOSES OF INFORMATION ONLY

Codes used to identify States party to the PCT on the front pages of pamphlets publishing international applications under the PCT.

AT	Austria	ES	Spain	MG	Madagascar
AU	Australia	FI	Finland	ML	Mali
BB	Barbados	FR	France	MN	Mongolia
BE	Belgium	GA	Gabon	MR	Mauritania
BF	Burkina Faso	GB	United Kingdom	MW	Malawi
BG	Bulgaria	GN	Guinea	NL	Netherlands
BJ	Benin	GR	Greece	NO	Norway
BR	Brazil	HU	Hungary	PL	Poland
CA	Canada	IT	Italy	RO	Romania
CF	Central African Republic	JP	Japan	SD	Sudan
CG	Congo	KP	Democratic People's Republic of Korea	SE	Sweden
CH	Switzerland	KR	Republic of Korea	SN	Senegal
CI	Côte d'Ivoire	LI	Liechtenstein	SU	Soviet Union
CM	Cameroon	LK	Sri Lanka	TD	Chad
CS	Czechoslovakia	LU	Luxembourg	TG	Togo
DE	Germany	MC	Monaco	US	United States of America
DK	Denmark				

Apparatus for detecting failure of an antenna amplifier unit with a hot standby redundancy

5 The invention relates to an apparatus for detecting failure of an antenna amplifier unit, replicated on the hot standby principle, in a receiving unit positioned apart from an antenna, the receiving unit comprising power supply means for supplying operating voltage to the antenna amplifier
10 unit through an antenna cable.

To improve the sensitivity of radio receivers, an antenna amplifier or preamplifier is often placed at the top of the antenna mast in close vicinity to the antenna, whereby a signal received by the antenna
15 can be amplified before it is applied through an antenna cable to the primary receiver positioned at the foot of the mast or close to it. To increase the reliability and redundancy, the antenna amplifier is often replicated on the hot standby principle: both
20 the amplifier in use and the amplifier in reserve assumes a full operating mode, so that when the amplifier in use fails, the signal can be passed immediately to the standby amplifier without interfering with the reception. The power source is usually positioned in connection with the receiver at the
25 foot of the mast and the operating voltage is supplied to the amplifier positioned in the mast through the antenna cable, so that the need for a separate power supply cable is avoided.

30 A problem with such an arrangement is, however, that information concerning the failure of the amplifier positioned in the mast and the replacement of it with the other amplifier should be transmitted to the receiver in order to be able to start the
35 required repair operations. One approach is to use an

extra cable for the transmission of the alarm. This, however, is inconvenient if there are no provisions for extra cables. The need for an extra cable can be avoided by transmitting the alarm information in the form of a modulated signal through the antenna cable to the receiver. Among the disadvantages of this method are that it causes interferences and requires a complicated equipment with resulting costs.

The object of the present invention is to provide an apparatus by means of which alarm information can be transmitted from the mast simply and advantageously without the need for separate cables.

This is achieved by means of an apparatus of the type disclosed in the introduction, which according to the invention is characterized in that the antenna amplifier unit comprises control means responsive to a failure of an amplifier for disconnecting the amplifier from the supply of operating voltage, and that the power supply means are capable of detecting a change in power consumption resulting from the disconnection of the amplifier from the supply of operating voltage and thereby the failure of the amplifier.

In the following the invention will be described in greater detail by means of an exemplifying embodiment with reference to the attached figure, which is a block diagram of an apparatus according to the invention.

The figure shows an antenna amplifier or pre-amplifier unit 1 positioned in close vicinity to a receiving antenna 3, e.g. in an antenna mast or some other place where the antenna is positioned, so as to amplify a radio-frequency signal received by the antenna 3 before the signal is applied through an antenna cable 4 to a receiving unit 2 positioned at a

greater distance from the antenna, e.g. at the foot of the antenna mast or close to it. According to the requirements in each particular case, the receiving unit 2 may be of any type, such as a base station in a cellular mobile telephone system. The receiving unit 2 comprises a power source unit 20 for supplying operating voltage through a coaxial antenna cable 4 to the amplifier unit 1. Even though the power source unit 20 is considered to be a functional part of the receiving unit 2, it may be positioned in practice apart from the radio sections of the receiving unit 2.

The amplifier unit 1 comprises a bandpass filter 10 for separating a desired frequency band from the signal fed by the antenna 3. To assure the reliability and redundancy of the amplifier unit, it is replicated on the hot standby principle. For this purpose the unit comprises at least two separate high-frequency amplifiers LNA1 and LNA2 of which one serves as an active amplifier through which the signal is passed, and the other is in reserve ready for operation, that is, in a hot standby mode. For the selection of the amplifier, the amplifier unit 1 comprises a change-over switch S1, which connects the output of the filter 10 to the input of the amplifier LNA1 or LNA2, and a change-over switch S2 which connects, through a blocking capacitor C1, the output of the amplifier LNA1 or LNA2, respectively, to the output of the unit 1.

The amplifier unit 1 further comprises a control unit 10 which is connected through a coil L1 to the center wire of the coaxial antenna cable 4 for receiving operating voltage and for generating separate operating voltages Vcc1 and Vcc2 to be applied to the amplifiers LNA1 and LNA2. The control

unit 10 monitors the condition of the amplifiers LNA1 and LNA2 by observing their power consumption by means of measuring circuits formed by resistors R1 and R2 and differential amplifiers CNA1 and CNA2, respectively. The measuring circuits produce signals cd1 and cd2 proportional to the power consumption of the amplifiers LNA1 and LNA2, respectively. The signals are applied to the control unit 10, and when the control unit 10 detects, e.g. in the situation of the figure on the basis of the signal cd1, that the amplifier LNA 1 has a failure, it immediately changes the state of a switch control signal SC so that the switches S1 and S2 switch the received signal to pass through the amplifier LNA2. In addition, the control unit 10 disconnects the amplifier LNA1 from the supply of the operating voltage Vcc1. If, in the situation of the figure, the failing amplifier is the amplifier LNA2, the control unit 10 only cuts off the operating voltage Vcc2.

The power control unit 20 comprises a voltage source and control unit 21 which is connected through a coil L2 to the center wire of the antenna cable 4 for supplying the operating voltage +12V to the amplifier unit 1. The unit 21 monitors the power consumption of the amplifier unit 1 and when it detects a reduction in the power consumption as a result of an interruption in the supply of one of the operating voltages Vcc1 and Vcc2, indicating failure of one amplifier, it generates an alarm signal ALARM for the control system of the receiving unit 2 or the operating staff. The measuring of the power consumption and the generation of the alarm signal can be realized in many ways obvious to one skilled in the art.

The figure and the description related to it

are only intended to illustrate the present invention. In its details, the apparatus of the invention may vary within the scope of the attached claims.

Claim:

Apparatus for detecting failure of an antenna amplifier unit (1), replicated on the hot standby principle, in a receiving unit (2) positioned apart from an antenna (3), the receiving unit comprising power supply means (20) for supplying operating voltage to the antenna amplifier unit through an antenna cable (4), characterized in that the antenna amplifier unit (1) comprises control means (10) responsive to a failure of an amplifier for disconnecting the amplifier (LNA1, LNA2) from the supply of operating voltage, and that the power supply means (20) are capable of detecting a change in power consumption resulting from the disconnection of the amplifier from the supply of operating voltage and thereby the failure of the amplifier (LNA1, LNA2).

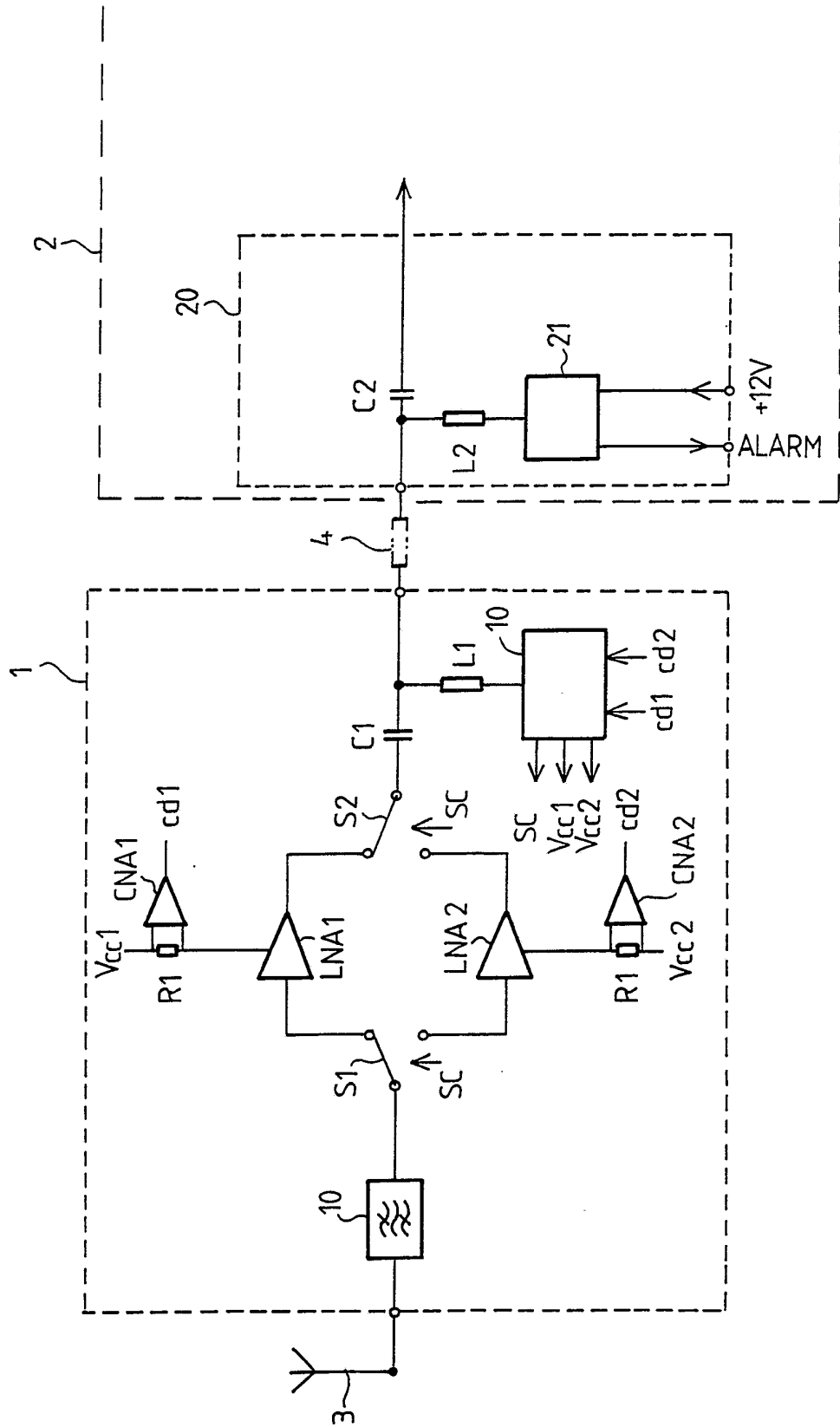

INTERNATIONAL SEARCH REPORT

International Application No PCT/FI 91/00180

I. CLASSIFICATION OF SUBJECT MATTER (if several classification symbols apply, indicate all) ⁶		
According to International Patent Classification (IPC) or to both National Classification and IPC		
IPC5: H 03 F 3/68, H 04 B 1/74		
II. FIELDS SEARCHED		
Minimum Documentation Searched ⁷		
Classification System	Classification Symbols	
IPC5	H 03 F, H 04 B, H 05 K	
Documentation Searched other than Minimum Documentation to the Extent that such Documents are Included in Fields Searched ⁸		
SE,DK,FI,NO classes as above		
III. DOCUMENTS CONSIDERED TO BE RELEVANT⁹		
Category *	Citation of Document, ¹¹ with indication, where appropriate, of the relevant passages ¹²	Relevant to Claim No. ¹³
A	US, A, 4565972 (D. P. KAEGEBEIN) 21 January 1986, see column 2, line 13 - line 31; figure 1 --	1
A	US, A, 4748423 (L. JINICH) 31 May 1988, see column 1, line 4 - line 52; column 4, line 63 - column 5, line 4; figures 1,2 --	1
A	US, A, 3305791 (B.S. WOLFE ET AL) 21 February 1967, see figures 1,2 --	1
A	US, A, 3345578 (D.G. SHUDA) 3 October 1967, see column 3, line 46 - line 63; figures 1,2 -- -----	1
<p>* Special categories of cited documents:¹⁰</p> <p>"A" document defining the general state of the art which is not considered to be of particular relevance</p> <p>"E" earlier document but published on or after the international filing date</p> <p>"L" document which may throw doubts on priority claim(s) or which is cited to establish the publication date of another citation or other special reason (as specified)</p> <p>"O" document referring to an oral disclosure, use, exhibition or other means</p> <p>"P" document published prior to the international filing date but later than the priority date claimed</p> <p>"T" later document published after the international filing date or priority date and not in conflict with the application but cited to understand the principle or theory underlying the invention</p> <p>"X" document of particular relevance, the claimed invention cannot be considered novel or cannot be considered to involve an inventive step</p> <p>"Y" document of particular relevance, the claimed invention cannot be considered to involve an inventive step when the document is combined with one or more other such documents, such combination being obvious to a person skilled in the art.</p> <p>"&" document member of the same patent family</p>		
IV. CERTIFICATION		
Date of the Actual Completion of the International Search		Date of Mailing of this International Search Report
16th September 1991		1991 -09- 18
International Searching Authority		Signature of Authorized Officer
SWEDISH PATENT OFFICE		<i>Bertil Ljungdahl</i> BERTIL LJUNGDAHL

ANNEX TO THE INTERNATIONAL SEARCH REPORT
ON INTERNATIONAL PATENT APPLICATION NO.PCT/FI 91/00180

This annex lists the patent family members relating to the patent documents cited in the above-mentioned international search report.
The members are as contained in the Swedish Patent Office EDP file on 91-08-30
The Swedish Patent Office is in no way liable for these particulars which are merely given for the purpose of information.

Patent document cited in search report	Publication date	Patent family member(s)	Publication date
US-A- 4565972	86-01-21	NONE	
US-A- 4748423	88-05-31	NONE	
US-A- 3305791	67-02-21	NONE	
US-A- 3345578	67-10-03	NONE	