

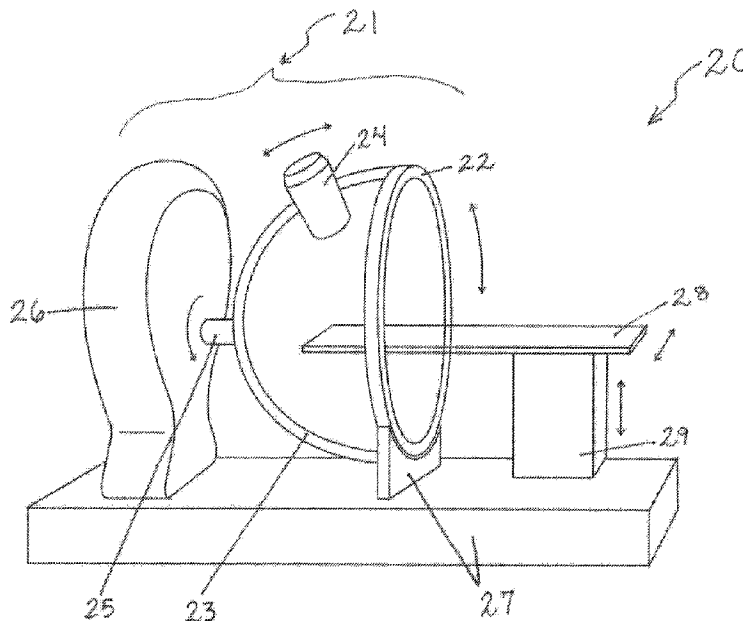

(86) Date de dépôt PCT/PCT Filing Date: 2015/01/05
(87) Date publication PCT/PCT Publication Date: 2015/07/09
(45) Date de délivrance/Issue Date: 2023/10/31
(85) Entrée phase nationale/National Entry: 2016/06/28
(86) N° demande PCT/PCT Application No.: US 2015/010197
(87) N° publication PCT/PCT Publication No.: 2015/103564
(30) Priorité/Priority: 2014/01/05 (US14/147,553)

(51) Cl.Int./Int.Cl. *A61N 5/10* (2006.01),
A61B 6/00 (2006.01)
(72) Inventeur/Inventor:
YU, XINSHENG CEDRIC, US
(73) Propriétaire/Owner:
XCISION MEDICAL SYSTEMS, LLC, US
(74) Agent: GOWLING WLG (CANADA) LLP

(54) Titre : PROCÉDE ET SYSTÈME POUR UNE ARCTHÉRAPIE STÉRÉOTACTIQUE À INTENSITÉ MODULÉE
(54) Title: METHOD AND SYSTEM FOR STEREOTACTIC INTENSITY-MODULATED ARC THERAPY



(57) **Abrégé/Abstract:**

A method of irradiating a target in a patient comprising directing a beam of radiation from an external source of radiation 24 at the target in the patient from numerous directions in a broad solid angle by longitudinally rotating the external source of radiation 24 around a central axis and simultaneously or sequentially, in either order, latitudinally rotating the external source of radiation 24; a globe gantry 21 comprising (i) a front opening ring 22 with its origin on the central axis of the globe gantry 21, (ii) at least one arc-shaped, gantry support arm 23, which has a front end and a rear end and is part of a circle, (iii) an external source of radiation 24, which is mounted on at least one arc-shaped, gantry support arm 23 and is movable along the gantry support arm to vary the latitude of the beam angle, (iv) a rear rotational axle 25 with an axis along the central axis of the globe gantry 21, (v) a support base 27, and (vi) a rear housing 26 comprising a source of power, mechanisms for moving components of the globe gantry 21, and controllers for controlling the movement of the components of the globe gantry 21 and the irradiation of the target in the patient; a system 20 comprising the globe gantry 21; and a method of irradiating a target in a patient using the system.



(12) INTERNATIONAL APPLICATION PUBLISHED UNDER THE PATENT COOPERATION TREATY (PCT)

(19) World Intellectual Property
Organization
International Bureau(10) International Publication Number
WO 2015/103564 A1(43) International Publication Date
9 July 2015 (09.07.2015)

- (51) International Patent Classification:
A61N 5/10 (2006.01) A61B 6/00 (2006.01)
- (21) International Application Number:
PCT/US2015/010197
- (22) International Filing Date:
5 January 2015 (05.01.2015)
- (25) Filing Language: English
- (26) Publication Language: English
- (30) Priority Data:
14/147,553 5 January 2014 (05.01.2014) US
- (72) Inventor; and
(71) Applicant : YU, XINSHENG Cedric [US/US]; 200 Bay Front Drive, Pasadena, Maryland 21122 (US).
- (74) Agent: LARCHER, Carol; Larcher & Chao Law Group, P.O. Box 1666, Skokie, Illinois 60076 (US).
- (81) Designated States (unless otherwise indicated, for every kind of national protection available): AE, AG, AL, AM, AO, AT, AU, AZ, BA, BB, BG, BH, BN, BR, BW, BY,

BZ, CA, CH, CL, CN, CO, CR, CU, CZ, DE, DK, DM, DO, DZ, EC, EE, EG, ES, FI, GB, GD, GE, GH, GM, GT, HN, HR, HU, ID, IL, IN, IR, IS, JP, KE, KG, KN, KP, KR, KZ, LA, LC, LK, LR, LS, LU, LY, MA, MD, ME, MG, MK, MN, MW, MX, MY, MZ, NA, NG, NI, NO, NZ, OM, PA, PE, PG, PH, PL, PT, QA, RO, RS, RU, RW, SA, SC, SD, SE, SG, SK, SL, SM, ST, SV, SY, TH, TJ, TM, TN, TR, TT, TZ, UA, UG, US, UZ, VC, VN, ZA, ZM, ZW.

- (84) Designated States (unless otherwise indicated, for every kind of regional protection available): ARIPO (BW, GH, GM, KE, LR, LS, MW, MZ, NA, RW, SD, SL, ST, SZ, TZ, UG, ZM, ZW), Eurasian (AM, AZ, BY, KG, KZ, RU, TJ, TM), European (AL, AT, BE, BG, CH, CY, CZ, DE, DK, EE, ES, FI, FR, GB, GR, HR, HU, IE, IS, IT, LT, LU, LV, MC, MK, MT, NL, NO, PL, PT, RO, RS, SE, SI, SK, SM, TR), OAPI (BF, BJ, CF, CG, CI, CM, GA, GN, GQ, GW, KM, ML, MR, NE, SN, TD, TG).

Published:

— with international search report (Art. 21(3))

(54) Title: METHOD AND SYSTEM FOR STEREOTACTIC INTENSITY-MODULATED ARC THERAPY

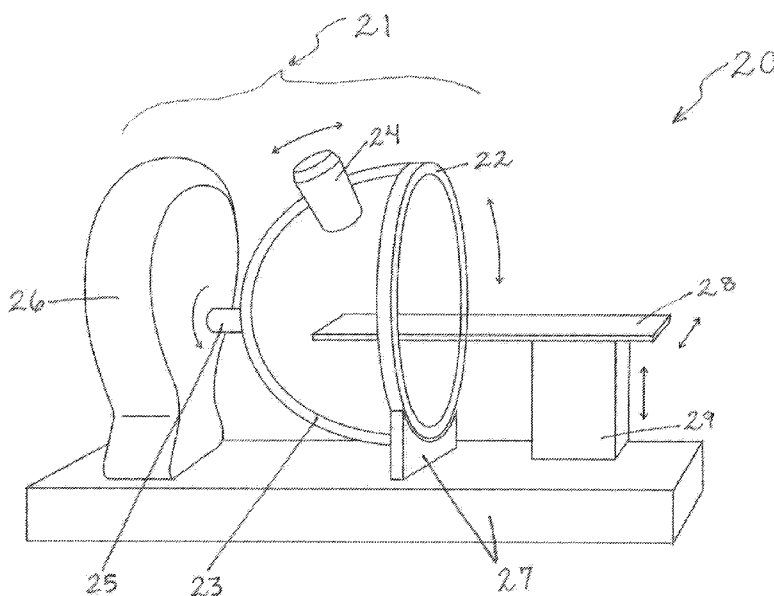

(57) Abstract: A method of irradiating a target in a patient comprising directing a beam of radiation from an external source of radiation 24 at the target in the patient from numerous directions in a broad solid angle by longitudinally rotating the external source of radiation 24 around a central axis and simultaneously or sequentially, in either order, latitudinally rotating the external source of radiation 24; a globe gantry 21 comprising (i) a front opening ring 22 with its origin on the central axis of the globe gantry 21, (ii) at least one arc-shaped, gantry support arm 23, which has a front end and a rear end and is part of a circle, (iii) an external source of radiation 24, which is mounted on at least one arc-shaped, gantry support arm 23 and is movable along the gantry support arm to vary the latitude of the beam angle, (iv) a rear rotational axle 25 with an axis along the central axis of the globe gantry 21, (v) a support base 27, and (vi) a rear housing 26 comprising a source of power, mechanisms for moving components of the globe gantry 21, and controllers for controlling the movement of the components of the globe gantry 21 and the irradiation of

the target in the patient; a system 20 comprising the globe gantry 21; and a method of irradiating a target in a patient using the system.

WO 2015/103564 A1

METHOD AND SYSTEM FOR STEREOTACTIC INTENSITY-MODULATED ARC THERAPY

[001]

TECHNICAL FIELD

[002] The present disclosure relates to radiation therapy, in particular a method and a system for delivering focused radiation from outside of a patient's body to a target inside the patient. The method and the system aim intensity-modulated external radiation beams from a wide solid angle to deliver a focal dose of radiation to the target.

BACKGROUND

[003] Radiation therapy is used to treat cancers and other conditions in patients. About half of all cancer patients receive some type of radiation therapy sometime during the course of their treatments. One commonly used form of radiation therapy is external beam radiation therapy. In external beam radiation therapy a high-energy, x-ray beam generated by a machine, usually a linear accelerator (linac), a gamma-ray beam emitted from an isotope, or charged particles generated from a particle accelerator is/are directed at a tumor or cancerous cells (i.e., the "target") inside the patient's body. While the radiation kills the cancerous cells, it also harms normal tissue and organs in the vicinity of the tumor/cancerous cells in the patient. Thus, the goal in radiation therapy is to deliver the required dose of radiation to the target volume, while minimizing the radiation dose to surrounding normal tissue that may cause complications and harm to the patient.

[004] Before a patient is treated with radiation, a radiation treatment plan must be developed through a process called "treatment planning," which begins with simulation. During simulation, detailed imaging scans show the location of a patient's tumor and the normal areas around it. These scans are usually performed using computed

tomography (CT), but they also can be performed using magnetic resonance imaging (MRI), x-rays or ultrasound.

[005] The ability of radiation therapy to achieve the goal of tumor eradication and normal tissue sparing depends on the degrees of freedom provided by the radiation delivery machine and on the physics of dose deposition. These freedoms and physics principles are incorporated in the treatment planning process.

[006] Most existing linear accelerators or teletherapy machines can rotate around an axis by the rotation of the gantry on which the source of radiation is mounted. See, for example, Fig. 1, which is a drawing of a basic structure of a typical radiation treatment system in which a radiation-emitting head is mounted on a rotatable C-arm gantry. The locus of the radiation source forms a circle. During gantry rotation, the radiation beam is pointed at the rotational center, commonly referred to as the "isocenter." This design limits the beam directions to mostly coplanar angles and, therefore, limits the quality of treatment plans achievable with the photon beams.

[007] A common type of external-beam radiation therapy is called three-dimensional conformal radiation therapy (3D-CRT). 3D-CRT allows the radiation beams to be shaped from a limited number of fields to conform to the beam's eye-view of the target area. A more advanced method of radiation treatment is intensity-modulated radiation therapy (IMRT), which provides more freedom than 3D-CRT by allowing the intensities of the radiation beams to vary within a radiation field in addition to field shaping. The goal of IMRT is to increase the radiation dose to the areas that need it and reduce radiation exposure to specific sensitive areas of surrounding normal tissue. The treatment planning system optimizes the beam intensity distribution to achieve maximally this goal. Compared with 3D-CRT, IMRT can reduce the risk of some side effects, such as damage to the salivary glands (which can cause dry mouth or xerostomia), when the head and neck are treated with radiation therapy (Veldeman et al., "Evidence behind use of intensity-modulated radiotherapy: A systematic review of comparative clinical studies," *Lancet Oncology* 9(4): 367–375 (2008); and Erratum in: *Lancet Oncology* 9(6): 513 (2008)). 3D-CRT and IMRT are typically delivered using a linear accelerator mounted on a C-arm gantry (as shown in Fig. 1) or a ring-like gantry, which is capable of only single plane rotation.

[008] Tomotherapy (Detorie, "Helical Tomotherapy: A new tool for radiation therapy," *J. Amer. Coll. Radiol.* 5(1): 63–66 (2008)) and intensity-modulated arc therapy (IMAT) (Yu, "Intensity modulated arc therapy using dynamic multi-leaf collimation: An alternative to Tomotherapy," *Phys. Med. Biol.* 40(9): 1435-1449 (1995)) are IMRT deliveries in rotational forms. In tomotherapy the patient is translated linearly as the source of radiation is making circular movements, thereby the relative motion of the radiation beam and the patient is a helix. Because the gantry on which the linear accelerator is mounted can only rotate in a single transverse plane, such "coplanar" rotational IMRT methods limit the range of beam directions available to create an optimal plan. Consequently, these techniques have not been shown to create significantly better dose distributions than IMRT with fixed beams.

[009] Stereotactic radiosurgery (SRS) and stereotactic body radiation therapy (SBRT) deliver one or more high doses of radiation to a small tumor (R. Timmerman and B. Kavanagh, "Stereotactic body radiation therapy," *Curr. Probl. Cancer* 29: 120-157 (2005)). SRS is commonly used for treating intracranial lesions and requires the use of a head frame or other device to immobilize the patient during treatment to ensure that the high dose of radiation is delivered accurately. The Gamma Knife (Bhatnagar et al., "First year experience with newly developed Leksell Gamma Knife Perfexion," *J. Med. Phys.* 34(3): 141-148 (2009)) is a dedicated SRS system for treating intracranial lesions. Gantry-based linear accelerator systems are also used for SRS. Both allow radiation beams to be incident on the target from directions outside the transverse plane. SBRT is used to treat tumors that lie outside the brain. SBRT is usually given in more than one treatment session. Methods of extending the Gamma Knife concept to the rest of the body are also proposed, such as with the GammaPod system for the treatment of breast cancer (Yu, et al., "GammaPod—A new device dedicated for stereotactic radiotherapy of breast cancer," *Med. Phys.* 40(5): 1703 (2013)) and the use of multiple sources mounted on an arc element that rotates (Pastyr et al., U.S. Patent No. 6,259,762 B) for treating tumor sites other than in the brain. The principle of SRS and SBRT is geometric focusing of the beams to create a high dose within the target volume with a fast fall off of dose outside this volume. Focusing is achieved by aiming the radiation beams at the target from hundreds or thousands of directions. However, the ability to modulate the shape and intensity of these beams is limited. As such, SRS and SBRT

have limited ability to spare surrounding tissues while maintaining a high and uniform dose within the target volume.

[010] Techniques for delivering intensity modulated radiation from a large number of beam angles have been proposed. The CyberKnife system (J. Adler, "CyberKnife radiosurgery for brain and spinal tumors," International Congress Series 1247: 545-552 (2002)) employs a linear accelerator mounted on a robotic arm. It can deliver radiation from a large number of non-coplanar angles, but the practical number of beam angles is limited by the long treatment times associated with a large number of independent beams. Furthermore, the range of beam directions from the posterior hemisphere of the patient is restricted because of geometry constraints. Furthermore, the degree of beam modulation is limited by its collimator design.

[011] Maurer and colleagues at Accuray, Inc., have proposed a number of alternative solutions using a fixed ring gantry, rather than a robotic arm (U.S. Pat. App. Pub. No. US 2011/0210261 A1; U.S. Pat. App. Pub. No. US 2011/0301449 A1; and U.S. Pat. App. Pub. No. US 2012/0189102 A1). While ring gantries are desirable for diagnostic imaging, where a single transverse plane or limited non-coplanar angles are used for the imaging beams, they are not ideal for treatment where a larger range of non-coplanar angles is desirable. For radiation treatment of most anatomical sites, the radiation beams are preferably directed to the target from one side of the patient's transverse axis, often from a large angle relative to this axis. For example, in treating intracranial lesions, most beams should be directed from the upper hemisphere (above the top of the patient's head) rather than from the lower hemisphere. In treating prostate cancer, it is generally preferable to direct beams from the lower body, rather than from the upper body, because it is better to have the beams go through less tissue and critical structures in the abdominal region. The ring gantry systems proposed by Maurer and colleagues have limited ability to take advantage of such anatomical preferences or achieve highly non-coplanar beam directions.

[012] The present disclosure seeks to overcome the limitations of the attendant systems and methods currently available in the art by providing, among other things, a method to allow radiation beams of varying intensity and field shape to be focused from a broad solid angle by combined longitudinal and latitudinal rotations of the radiation source. In view of the foregoing, the present disclosure describes a method and a

radiation delivery system to increase further the utility and clinical efficacy of photon-based treatment systems via increasing the degrees of freedom in beam delivery beyond that achievable with existing IMRT and SRS/SBRT systems. Specifically, this is achieved by allowing intensity-modulated photon beams to be delivered from a very large number of beam directions, including those which are highly non-coplanar. The solid angle range includes all longitudinal angles (about the patient's longitudinal axis) and a broad range of latitudinal angles. The methods and system combine, in a practical design, the geometric focusing of SRS/SBRT and intensity modulation of IMRT, thereby providing capabilities not attainable by either IMRT or SRS/SBRT alone. This and other objects and advantages, as well as inventive features, will become apparent from the detailed descriptions provided herein.

SUMMARY

[013] A method of irradiating a target in a patient is provided. The method comprises directing a beam of radiation from an external source of radiation, such as at least one external source of radiation, at the target in the patient from numerous directions in a broad solid angle by longitudinally rotating the external source of radiation around a common isocenter concentrically and simultaneously or sequentially, in either order, latitudinally rotating the external source of radiation. The intensity of the beam of radiation, the shape of the aperture of the beam of radiation, or both the intensity and the shape of the aperture of the beam of radiation can be varied during irradiation throughout different points of longitudinal and/or latitudinal rotation or during maintenance of the external source of radiation at a single, static location. The speed of longitudinal rotation of the external source of radiation, the speed of latitudinal rotation of the external source of radiation, or both the speed of longitudinal rotation and the speed of latitudinal rotation of the external source of radiation can be varied. The method can further comprise continuously or discontinuously moving the patient during irradiation.

[014] Further provided is a globe gantry for longitudinally and latitudinally rotating an external source of radiation, such as at least one external source of radiation, concentrically around an isocenter placed in a target to be irradiated. The globe gantry has a central axis intersecting the isocenter and comprises as components (i) a front opening ring with its origin on the central axis of the globe gantry, (ii) at least one arc-

shaped, gantry support arm, which has a front end and a rear end and is part of a circle, (iii) an external source of radiation, such as at least one external source of radiation, which is mounted on at least one arc-shaped, gantry support arm and can move along the arc-shaped, gantry support arm to rotate latitudinally about the isocenter, and optionally, a beam stopper, which is mounted on at least one arc-shaped, gantry support arm, and wherein the beam stopper is on the opposite side of the globe gantry from the external source of radiation, (iv) a rear rotational axle with an axis along the central axis of the globe gantry, (v) a support base, and (vi) a rear housing comprising a source of power, mechanisms for moving components of the globe gantry, and controllers for controlling the movement of the components of the globe gantry and the irradiation of the target in the patient. The front opening ring is attached to the front end of the at least one arc-shaped, gantry support arm. The rear rotational axle is attached to the rear end of the at least one arc-shaped, gantry support arm. The front opening ring and the rear rotational axle are supported by the support base and the rear housing. The front opening ring and the rear rotational axle can rotate around the central axis causing the external source of radiation to rotate longitudinally. The external source of radiation is a linear accelerator or a radioisotope teletherapy device. The external source of radiation can move along the length of the at least one arc-shaped, gantry support arm on which it is mounted at a variable speed. Alternatively, the external source of radiation is fixed on at least one arc-shaped, gantry support arm, and the arc-shaped, gantry support arm and the rear rotational axle are translated to cause the external source of radiation to rotate latitudinally at variable speed. The globe gantry can have a radius from about 40 cm to about 100 cm. The orientation of the central axis of the globe gantry can be changed from horizontal to substantially vertical or vertical, in which case the rear housing can rotate longitudinally and pivot between horizontal and vertical positions along with the globe gantry.

[015] Still further provided is a system for irradiating a target in a patient. The system comprises (i) a globe gantry, (ii) a patient platform, (iii) a patient platform support, and, optionally, (iv) a shield. The patient platform can be independently moved in either direction along the length of the patient platform or z-dimension, in either direction along the width of the patient platform or x-dimension, and/or in either direction above or below the patient platform or y-direction. The movement(s) of the patient platform

is/are in synchrony with the longitudinal and latitudinal rotations of the radiation source and are controlled centrally by the control unit that coordinates all the movements during irradiation of the patient. The patient platform support supports the patient platform. The shield separates the patient from the rest of the system.

[016] The system can further comprise (v) at least two straight support beams, (vi) an x-ray tube, and (vii) an x-ray detector array. The x-ray tube is mounted on at least one straight support beam on one side of the globe gantry. The x-ray detector array is mounted on at least one straight support beam on the opposite side of the globe gantry from the x-ray tube and can move along the lengths of the at least two straight support beams to which they are mounted. The at least two straight support beams are parallel with the central axis of the globe gantry. The x-ray tube and the x-ray detector array are mounted on a separate rotational axle, and can move along the lengths of the at least two straight support beams to which they are mounted. The x-ray detector array can be one-dimensional or multi-dimensional, such as two-dimensional. The two straight support beams are supported at the front end by a bearing mounted on the front ring of the globe gantry and at the rear end by a bearing coaxial with, but separate from, the rear rotational axle of the globe gantry. The two straight support beams can rotate independently, i.e., longitudinally independently, of the rotation, i.e., longitudinal rotation, of the globe gantry. By translating the x-ray tube and the detector complex along the straight support arms and rotating around the patient independently of the globe gantry rotation, CT images can be acquired before, during, and after radiation treatment.

[017] Alternatively, the system can further comprise (viii) a computed tomography (CT) imaging system, a magnetic resonance imaging (MRI) system, or a positron emission tomography (PET)/computed tomography (CT) imaging system positioned adjacent to the front opening ring of the globe gantry, wherein the CT imaging system, the MRI system, or the PET/CT imaging system can provide on-board imaging guidance.

[018] Still further provided is a method of irradiating a target in a patient under imaging guidance using the system. The method comprises a) imaging the patient in the treatment position, using the x-ray tube and x-ray detector complex or using the attached or adjacent volumetric imaging system (CT, MRI, or PET/CT); b) developing a treatment plan to deliver a focal radiation dose by directing intensity-modulated

beams of radiation from the external source of radiation at the target in the patient in a treatment position from numerous directions in a broad solid angle by longitudinally rotating the external source of radiation around a central axis and simultaneously or sequentially, in either order, latitudinally rotating the external source of radiation, while continuously or discontinuously moving the patient; c) delivering the treatment according to the treatment plan with the patient remaining on the patient platform of the same setup as with imaging in a); and d) during radiation treatment, imaging the patient using the x-ray tube and the x-ray detector array mounted on the straight support beams on opposite sides of the patient, wherein, if a change or changes in patient anatomy is/are detected, one or more of the treatment delivery parameters (e.g., the position of the patient support platform, the shape of the multileaf collimator, the longitudinal and/or latitudinal angles of the beam, and the beam intensity) is/are adjusted such that a target in the patient is irradiated in accordance with the treatment plan.

BRIEF DESCRIPTION OF THE FIGURES

[019] Fig. 1 is a drawing of a basic structure of a typical radiation treatment system in which a radiation-emitting head is mounted on a rotatable C-arm gantry.

[020] Fig. 2 is a drawing of a system **20** comprising a globe gantry **21**, which comprises a front opening ring **22**, a gantry support arm **23**, an external source of radiation **24** (e.g., at least one source of radiation), a rear rotational axle **25**, a rear housing **26**, and a support base **27**. Also shown are a patient platform **28** and a patient platform support **29**.

[021] Fig. 3(a) illustrates the coordinate system and the nomenclature associated with the front view of a globe gantry. The radius (R) is fixed. The location (P) of the source of radiation **24** is uniquely identified by its latitudinal angle (φ) and its longitudinal angle (θ), i.e., $P(\varphi, \theta)$.

[022] Fig. 3(b) illustrates the coordinate system and the nomenclature associated with a side view of a globe gantry, which includes a rear rotational axle **25**. The radius (R) is fixed. The location (P) of the source of radiation **24** is uniquely identified by its latitudinal angle (φ) and its longitudinal angle (θ), i.e., $P(\varphi, \theta)$.

[023] Fig. 4(a) shows a partial side view of a radiation treatment system **20** when the external source of radiation **24** mounted on an arc-shaped, gantry support arm **23** is latitudinally rotated to near the rear (closed) end of the globe gantry **21**, where the rear rotational axle **25** is located. Also shown are a patient platform **28** and a patient platform support **29**.

[024] Fig. 4(b) shows a partial side view of a radiation treatment system when the external source of radiation **24** mounted on an arc-shaped, gantry support arm **23** is latitudinally rotated to near the front (open) end of the globe gantry **21**. Also shown are a patient platform **28** and a patient platform support **29**.

[025] Fig. 5 partially shows a radiation treatment system **20** when viewed from the front opening ring **22**. Shown are the source of radiation **24** mounted on adjacent arc-shaped gantry support arms **23**, a patient platform **28**, and a support base **27** with rollers **30**.

[026] Fig. 6(a) illustrates the locus of the beam from the external source of radiation with constant speed of longitudinal and latitudinal rotation, whereby the locus of the beam from the external source of radiation forms a spherical helix. Shown is the rear rotational axle **25**.

[027] Fig. 6(b) illustrates the locus of the beam from the external source of radiation with slow longitudinal rotation and back and forth latitudinal rotation, whereby the locus of the beam from the external source of radiation forms a zigzag pattern on the surface of a sphere. Shown is the rear rotational axle **25**.

[028] Fig. 7 partially illustrates a system **20** configured as a dedicated device for treating the brain and head and neck tumors where the ranges of the latitudinal angles at the front and rear ends of the globe gantry **21** are highly asymmetric about the transverse plane across the origin of the globe. Shown are the front opening ring **22**, an arc-shaped, gantry support arm **23**, an external source of radiation **24**, a rear housing **26**, a rear rotational axle **25** connected to a rotation-enabling device **34**, such as a torque motor, and a patient platform **28**. The entire globe gantry **21** is supported by a supporting column **36**.

[029] Fig. 8 partially illustrates a system **20** configured as a dedicated device for treating cancers in a human breast pendent through an opening in a patient platform **28** positioned above the opening of the globe gantry, the longitudinal axis of rotation of

which is vertical. Shown are an arc-shaped, gantry support arm **23**, an external source of radiation **24**, and a rear rotational axle **25**.

[030] Fig. 9 illustrates an embodiment of the globe gantry **21** in which the longitudinal rotational axis can be pivoted between horizontal and vertical positions. A rear housing **26** comprises a source of power, mechanisms for moving components of the globe gantry, and controllers for controlling the movement of the components of the globe gantry and irradiation of the target in the patient. In this embodiment, the globe gantry **21** and rear housing **26** rotate together longitudinally by the torque motor **34** and pivot between horizontal and vertical positions through the rotation of the pivoting axle **30** supported by two supporting columns **36**. Shown are a front opening ring **22**, an arc-shaped, gantry support arm **23**, an external source of radiation **24**, a rear rotational axle **25**, a rear housing **26**, a torque motor **34**, and two supporting columns **36**.

[031] Fig. 10 illustrates an embodiment of the system **20** in which a recess at the rear end of the globe gantry **21** provides space for a patient's feet when treated in a "feet-in" orientation, such as for treatment of prostate cancer. The connection point for the rear axle **25** is at the rear end of the recess. Shown are a front opening ring **22**, arc-shaped, gantry support arms **23**, an external source of radiation **24**, a support base **27**, a patient platform **28**, and a patient platform support **29**.

[032] Fig. 11(a) shows a side view of a system **20** in which straight support beams **31** are attached to the globe gantry **21** through a separate axle bearing **36** to facilitate on-board imaging, such as 2-D x-ray or 3-D CT imaging. Shown are a front opening ring **22**, arc-shaped, gantry support arms **23**, an external source of radiation **24**, a rear rotational axle of globe gantry **25**, a rear housing **26**, a support base **27**, a patient platform **28**, a patient platform support **29**, and on-board imaging with an x-ray tube **32** and an x-ray detector array **33**.

[033] Fig. 11(b) shows the view from the front ring of the globe gantry **21** of a system **20** in which straight support beams **31** are attached to the globe gantry **21** to facilitate on-board imaging, such as 2-D x-ray or 3-D CT imaging. Shown are a front opening ring **22**, an external source of radiation **24**, and on-board imaging with an x-ray tube **32** and an x-ray detector array **33**.

Fig. 12 illustrates how a 3-D imaging device **32** with a ring gantry can be abutted at the front ring of the globe gantry **21** of a system **20** to allow a patient to be

imaged and treated while maintaining the same position on a patient platform. Shown are an arc-shaped, gantry support arm **23**, an external source of radiation **24**, a rear rotational axle **25**, a patient platform **28**, a patient platform support **29**, and on-board 3-D imaging device **35**.

DETAILED DESCRIPTION

[034] A method of irradiating a target in a patient is provided. The method comprises directing a beam of radiation from an external source of radiation, such as at least one external source of radiation, at the target in the patient from numerous directions (the directions can be so numerous as to be considered vast) in a broad solid angle. The external source of radiation is longitudinally rotated around the patient about an axis. Simultaneously with the longitudinal rotation or sequentially to the longitudinal rotation, in either order (i.e., either before or after), the external source of radiation can be rotated latitudinally via translation along a circular trajectory. Together, the longitudinal and latitudinal rotations of the external source of radiation in effect move the source of radiation in a trajectory that lies on the surface of a sphere. The range of latitudinal rotation is sufficient to allow large non-coplanar beam angles at one or both ends of the rotation range. Preferably, and even desirably, the central axis of the beam of radiation is focused on a fixed point in space throughout all rotations of the external source of radiation. This point is the "isocenter" or the intersection of the axes of longitudinal and latitudinal rotation. Thus, the external source of radiation is preferably, and even desirably, longitudinally rotated and latitudinally rotated concentrically around a common isocenter. The intensity of the beam of radiation, the shape of the aperture of the beam of radiation, or both the intensity and the shape of the aperture of the beam of radiation can be varied, such as during movement of the external source of radiation, i.e., during irradiation throughout different points of longitudinal and/or latitudinal rotation, or during maintenance of the external source of radiation at a single/static location. The speed of longitudinal rotation of the external source of radiation, the speed of latitudinal rotation of the external source of radiation, or both the speed of longitudinal rotation and the speed of latitudinal rotation of the external source of radiation can be varied. The breadth of the solid angle from within which the beam of radiation is directed can vary depending on the location of the target in the patient

being irradiated. The breadth of the solid angle spanned by these rotations can vary depending on the location of the target in the patient being irradiated, allowing customization of the delivery for different locations. When the external source of radiation is longitudinally rotated and latitudinally rotated at a constant speed, the path of the external source of radiation is a spherical helix as shown in Fig. 6(a), which illustrates the locus of the external source of radiation with constant speed of longitudinal and latitudinal rotation, whereby the locus of the beam source forms a spherical helix. The longitudinal rotation and the latitudinal rotation can be performed in both directions. When the external source of radiation is longitudinally rotated slowly and latitudinally rotated constantly back and forth, the path of the external source of radiation is a zigzag as shown in Fig. 6(b), which illustrates the locus of the external source of radiation with slow longitudinal rotation and back and forth latitudinal rotation, whereby the locus of the beam source forms a zigzag pattern on the surface of a sphere. When the external source of radiation is longitudinally rotated back and forth and latitudinally rotated slowly, the path of the external source of radiation is connected segments of helices of opposite directions. The method can further comprise continuously or discontinuously moving the patient during irradiation, thereby allowing the radiation focal point to move dynamically within the target or be statically placed at one or more positions in and around the target. This method is referred to as stereotactic intensity-modulated arc therapy (SIMAT).

[035] A globe gantry **21** for longitudinally and latitudinally rotating an external source of radiation concentrically around an isocenter placed in a target to be irradiated is also provided. The globe gantry **21** has a central axis intersecting the isocenter and can rotate the external source of radiation **24** throughout a 360° range about the central axis. This movement is referred to herein as "longitudinal rotation," and the external source of radiation is said to "rotate longitudinally" or "longitudinally rotate" or to be "longitudinally rotated" when it rotates around the central axis. Preferably, and even desirably, the globe gantry **21** can rotate in either direction, i.e., clockwise and counterclockwise. Also preferably, and even desirably, the globe gantry **21** can rotate at a variable speed. The globe gantry **21** comprises the following components: (i) a front opening ring **22** with its origin on the central axis of the globe gantry **21**, (ii) at least one arc-shaped, gantry support arm **23**, which has a front end and a rear end and is

part of a circle with its origin on the central axis of the globe gantry, (iii) an external source of radiation (**24**; also referred to as a "radiation generating device," a "radiation-emitting device," and a "radiation head"), which is mounted on at least one arc-shaped, gantry support arm **23**, and, optionally, a beam stopper, which is mounted on at least one arc-shaped, gantry support arm **23**, and wherein the beam stopper is on the opposite side of the globe gantry **21** from the external source of radiation **24**, (iv) a rear rotational axle **25** with an axis along the central axis of the globe gantry **21**, (v) a support base **27**, and (vi) a rear housing **26** comprising a source of power, mechanisms for moving components of the globe gantry **21**, and controllers for controlling the movement of the components of the globe gantry **21** and the irradiation of the target in the patient. The front opening ring **22** is attached to the front end of the at least one arc-shaped, gantry support arm **23**. Preferably, the front opening ring **22** is attached to the front ends of at least two arc-shaped, gantry support arms **23**, which are separated by longitudinal angles of 180°, or at least two pairs of adjacent arc-shaped, gantry support arms **23**, which pairs are separated by longitudinal angles of 180°. The curvature of the arc-shaped, gantry support arm(s) **23** enables movement of the external source of radiation **24** along a circular path with a fixed origin, i.e., the isocenter, that lies on the rotational axis of the globe gantry **21** and, when present, the beam stopper. The front opening ring **22** desirably provides support and rigidity. The front opening ring **22** is supported by rollers **30**, bearings, or the like set on the support base **27**, such that the front opening ring **22** can freely rotate on the support base **27**. The rear, rotational axle **25** is attached to the rear end of the at least one arc-shaped, gantry support arm **23** and facilitates longitudinal rotation of the globe gantry **21**. Longitudinal rotation also can be achieved by driving the front opening ring **22**. When there are at least two arc-shaped, gantry support arms **23**, preferably the rotational axle is attached to the rear ends of the at least two arc-shaped, gantry support arms **23**, and the two arc-shaped, gantry support arms **23** form part of a circle. With such a configuration, the arc-shaped, gantry support arms **23** are affixed to, and extend outwardly and forward from, the rear rotational axle **25**. The front opening ring **22** and the rear rotational axle **25** are supported by the support base **27** and the rear housing **26**. The front opening ring **22** and the rear rotational axle **25** can rotate around the central axis. Such a configuration, when rotated about the central axis, occupies a space

resembling part or all of a sphere or a globe. In this regard, the globe gantry can be slightly more or less hemispheric.

[036] Driving mechanisms can be attached at any suitable place(s) on the globe gantry. For example, driving mechanisms can be attached to the rear, rotational axle **25** and/or the front, opening ring **22**.

[037] Preferably, a slip ring is used to supply the electricity from the rear housing **26** to the power sources of the external source of radiation **24** mounted on the globe gantry, and to establish communication links between components, such as sensors, controllers, etc., mounted on the globe gantry and the stationary rear housing. The slip ring also may be used to transfer cooling water to and from the rotating globe gantry **21**. Slip-ring technology is not necessary when the globe gantry **21** is rotated back and forth with a maximum range of rotation in a single direction that does not significantly exceed 10 turns (i.e., 3600°).

[038] The driving mechanism of the globe gantry **21** is designed to prevent unintended rotation in the event that there is a loss of power and the weight on the globe gantry **21** is not balanced around the globe. In an embodiment, which can be preferred, a non-reversible, drivable gear mechanism is used. Such a mechanism serves to protect the patient and the globe gantry **21**, as well as a system **20** comprising the globe gantry.

[039] The globe gantry can have any suitable radius. Desirably, the globe gantry **21** has a radius that is large enough for the intended application. For treatment of tumors in the torso of a patient, the diameter of the front opening ring should be from 60 cm to 100 cm, sufficient to allow a patient, in particular a human patient, to be placed in the interior space of the globe gantry **21** and, optionally moved in three dimensions within the interior space of the globe gantry **21**. For breast, brain, and head/neck applications, the opening can be smaller.

[040] The orientation of the central axis of the globe gantry **21** can be changed. For example, the orientation of the central axis can be changed from horizontal to substantially vertical or vertical, in which case the rear housing can rotate longitudinally and pivot between horizontal and vertical positions along with the globe gantry. A substantially horizontal or horizontal orientation can allow, for example, a patient's head and a patient's body supported by a patient platform **28** to be placed inside the globe gantry. When the central axis is oriented substantially vertically or

vertically with the front ring **22** facing upwards, the patient can lay prone on a patient platform **28** in the globe gantry. In an embodiment the patient platform **28** comprises an opening for a breast of a female patient to be placed inside the globe gantry **21**, in which case the breast is pendent in the opening in the patient platform **28**.

[041] In an embodiment the external source of radiation **24** is mounted on a pair of adjacent arc-shaped, gantry support arms **23** for greater stability and better control of the external source of radiation **24** when it is moving along the length(s) of the arc-shaped, gantry support arm(s) **23**. Preferably, and even desirably, the external source of radiation **24** can move or translate along the length(s) of the arc-shaped, gantry support arm(s) **23** to which it is attached at a constant speed or a variable speed. Because the arc-shaped, gantry support arms **23** are part of a circle on the surface of a globe, this movement is referred to herein as "latitudinal rotation," and the external source of radiation is said to "rotate latitudinally" or "latitudinally rotate" or to be "latitudinally rotated" when it moves/translates along the length(s) of the gantry support arm(s) **23**. The position of the external source of radiation **24** can be uniquely identified by its longitudinal and latitudinal angles. The coordinate system and nomenclature associated with a globe gantry **21** used in a system **20** for planning SIMAT treatment is illustrated in Figs. 3(a) and 3(b). Fig. 3(a) illustrates the coordinate system and the nomenclature associated with the front view of a globe gantry **21**. The radius (R) is fixed. The location (P) of the source of radiation **24** is uniquely identified by its latitudinal angle (φ) and its longitudinal angle (θ), i.e., $P(\varphi, \theta)$. Fig. 3(b) illustrates the coordinate system and the nomenclature associated with a side view of a globe gantry **21**. The source of radiation **24** can be at different latitudinal and longitudinal angles, at all times pointing to the isocenter. Rotation of the globe gantry **21** changes the longitudinal angle of the beam of radiation. The latitudinal rotation of the external source of radiation **24** varies the latitudinal angle of the beam of radiation.

[042] The speed of longitudinal rotation and the speed of latitudinal rotation of the external source of radiation **24** can be, but need not be, and preferably are not, constant. The trajectory of the source of radiation **24** under such conditions is not a perfect spherical helix. Moreover, the longitudinal and latitudinal rotation of the external source of radiation **24** is generally not mono-directional, i.e., it can be rotated back and forth in both directions as needed, and each movement in one direction can be complete

or incomplete, i.e., longitudinal rotations that are not necessarily throughout 360 degrees and latitudinal rotations that do not necessarily involve translation of the source along the entire length(s) of the arc-shaped, gantry support arm(s) **23**. In this regard, the starting and stopping positions along the arc-shaped, gantry support arm(s) **23** can vary with the longitudinal angle of the location of the external source of radiation **24**. The axis of the radiation beam always points to the origin of the sphere.

[043] The range of the latitudinal angles is not symmetrical about the plane through the isocenter and perpendicular to the longitudinal axis of the globe gantry **21**. For the situation where the longitudinal axis is oriented along the length of the patient and patient platform **28**, this asymmetry of latitudinal rotation is about the vertical plane through the isocenter and transverse to the patient platform **28**. In the field of radiation oncology, radiation beams with their axes coplanar with a transverse plane of a patient platform (or patient) **28** are referred to as "coplanar beams," whereas radiation beams angled obliquely from above or below the transverse plane of the patient platform (or patient) **28** are referred to as "non-coplanar beams." For the situation where the longitudinal axis is oriented perpendicularly to the patient and patient platform (**28**; as in Fig. 8), the asymmetry of latitudinal rotation is about the horizontal plane through the isocenter. The beam of radiation has a smaller maximum obliquity at the front opening **22** end as compared to the rear closed end by the rear, rotational axle **25**. This configuration provides the largest possible solid angle without constricting the opening of the treatment space. This arrangement is desirable because it allows the treatment space to be sufficiently large to accommodate patients of varying size, and it enables irradiation of a wide range of target sites within a patient.

[044] An alternative mechanical system for moving at least one source of radiation in a sphere, while keeping the beam focused on a fixed location in space, is also provided. In this alternative mechanism, the radiation head **24** is fixed on the arc-shaped, gantry support arm **23**, and the arc-shaped, gantry support arm **23** and the rear, rotational axle **25** are translated, causing the external source of radiation **24** to rotate latitudinally.

[045] The globe gantry **21** can be made from any suitable material in accordance with methods known in the art. The globe gantry **21** is desirably made from a strong material that is durable and lightweight. Desirably, the globe gantry **21** can be easily rotated, and the support beams can support attachments, such as an external source of

radiation **24**, a beam stopper, and the like, and can withstand repeated movement of the external source of radiation **24** and, when present, the beam stopper along their lengths in both directions (i.e., the directions of latitudinal rotation). An example of a material is metal.

[046] A system **20** for irradiating a target in a patient is also provided. The system **20** comprises the following components: (i) a globe gantry **21** as described herein, (ii) a patient platform **28**, which is positioned along the central axis of the globe gantry **21** and which comprises a first end and a second end, (iii) a patient platform support **29**, which supports the patient platform **28**, and, optionally, (iv) a shield, which separates the patient from the rest of the system.

[047] Fig. 2 is a drawing of a system **20** comprising a globe gantry **21**. Rather than having the source of radiation fixed on a C-arm gantry, the arms of the globe gantry form part of a circle, and the external source of radiation **24** can latitudinally rotate along an arm of the gantry. When the gantry is longitudinally rotated and the external source of radiation **24** is rotated latitudinally along the arc-shaped support arm **23**, the locus of the movement of the source of radiation is generally part of the surface of a sphere, rather than a circle. During such movement, the radiation beam emitted from the external source of radiation **24** points to the origin of the sphere, the radiation intensity can be varied, and the aperture of the radiation field can be changed. Thereby, two of the widely adopted techniques for delivering radiation doses to conform to the shape of the target in a patient – intensity modulation and geometric focusing – can be combined. During the movement of the radiation beams, the patient can also be moved, allowing the rotational isocenter of the radiation beam to scan through the target in the patient analogously to three-dimensional printing or painting, thereby covering an irregularly shaped target (e.g., tumor) with the desired dose patterns.

[048] Fig. 4(a) shows a side view of a radiation treatment system **20** when the at least one source of radiation **24** mounted on an arc-shaped, gantry support arm **23** is latitudinally rotated to near the rear (closed) end of the globe gantry **21**. Because it is rarely desirable to direct the radiation beam towards the vertex of a patient's head or the bottom of a patient's feet, the latitudinal angle (ϕ) practically need not be smaller than about 30°.

[049] Fig. 4(b) shows a side view of a radiation treatment system **20** when the at least one source of radiation **24** mounted on an arc-shaped, gantry support arm **23** is latitudinally rotated to near the front (open) end of the globe gantry **21**. There is more latitudinal angular range on the rear side than on the front side of the transverse plane across the isocenter, thereby allowing large, non-coplanar beam angles from the closed end of the gantry. In most cases, it is not necessary to have the radiation beams arranged symmetrically about the transverse plane through the isocenter. Therefore, the latitudinal angle (φ) practically need not be greater than about 120° .

[050] Fig. 5 shows a radiation treatment system **20** when viewed from the front opening **22**. The globe gantry **21** can rotate smoothly, for example, on ball bearings in the support base **27**. The radiation head **24** is rotated to a longitudinal angle (θ).

[051] The external source of radiation **24** can be any suitable source of radiation. The external source of radiation **24** can be a self-contained radiation machine. Examples of sources of radiation **24** include, but are not limited to, a linear accelerator and a radioisotope teletherapy device, such as a cobalt-60 teletherapy head. When the external source of radiation **24** is a linear accelerator, the microwave power generator and/or amplifier for electron acceleration, the accelerator waveguide, as well as other necessary components for shaping the radiation field, are preferably all mounted on a single carrier, moving together as the source of radiation is latitudinally rotated. The high-voltage pulse generation modulator and other control circuitry can either be fixed on the globe gantry or placed inside the rear stationary housing. In the latter arrangement, the electrical power required to energize a radiation-generating head can be connected through a slip-ring mechanism. The external source of radiation **24** comprises the necessary shielding around the radiation source, a primary collimator, and a radiation aperture-shaping device, such as a multi-leaf collimator. The beam of radiation is collimated with the primary collimator. In an embodiment, which can be preferred, a multi-leaf collimator shapes the field of radiation dynamically during irradiation and movement.

[052] Optionally, the external source of radiation **24** is coupled with a beam stopper, which is mounted on at least one arc-shaped, gantry support arm **23** on the opposite side of the globe gantry **21** from the external source of radiation **24**. The beam stopper is a radiation-shielding plate that attenuates the exit beam from the patient. Examples

of suitable beam stoppers are known in the art and include, for example, a high-density material, such as lead encased in steel or tungsten alloy. In addition to shielding radiation from the external source of radiation **24**, the beam stopper can act as a counter-weight to the external source of radiation **24**. Preferably, and even desirably, the beam stopper can move along the length(s) of the arc-shaped, gantry support arm(s) **23** to which it is mounted and moves in the opposite direction of the external source of radiation **24**. Since the external source of radiation **24** moves at a constant speed or a variable speed, the beam stopper moves at a constant speed or a variable speed accordingly. The ability of the beam stopper to move helps to minimize the size of the beam stopper required to block the exit of the radiation beam from the patient. As the radiation head moves from a positive latitudinal angle to a negative latitudinal angle, the beam stopper moves from a negative latitudinal angle to a positive latitudinal angle (and *vice versa*) so as to maintain its function of blocking the exit beam from the patient. Alternatively, the beam stopper can be a fixed, arc-shaped plate that connects the front opening ring **22** to the rear, rotational axle **25**, serving both as a shield of the radiation exiting from the patient and as structural support providing rigidity to the globe gantry **21**. The width and the circular arc length of the shielding plate in this alternative embodiment are sufficient for shielding the exit beam when the radiation head is at any possible location on the globe gantry.

[053] An example of a patient platform **28** is a table or a couch. In an embodiment the patient platform **28** can be independently moved in various directions. For example, the patient platform **28** can be moved in either direction along the length of the patient platform **28** or z-dimension, in either direction along the width of the patient platform **28** or x-dimension, and/or in either direction above or below the patient platform **28** or y-direction. Such movements are in synchrony with the longitudinal and latitudinal rotations of the external source of radiation. Independent movement of the patient platform **28** in three directions can be driven by at least three motors, for example. Depending on the location of the target in the patient to be irradiated, it can be desirable to have the patient lie on the patient platform **28** with his/her head at the first end or the second end.

[054] Any suitable patient platform support **29** can be used to support the patient platform. An example of a suitable patient platform support **29** is a pedestal, inside of

which the driving mechanisms for the patient platform movements are arranged. The patient platform support **29** allows the patient platform **28** to be suspended inside the globe gantry **21**. The patient platform support **29** can also be a multi-axis robotic arm. [055] The support base **27** can be any suitable supportive structure, such as a solid platform, that stabilizes the front opening ring **22**, the rear, rotational axle **25**, and, if desired, the patient platform **28**, for better geometric stability.

[056] The shield, which separates the patient from the rest of the system **20**, can be any suitable shield as known in the art. Preferably, the shield is thin and protective and separates the patient from the globe gantry **21**, the external source of radiation **24**, and other moving parts, which are mounted on or adjacent to the globe gantry **21**. The shield can have any suitable shape, such as a hemispherical shape, and can be established around the patient prior to treatment. The shield can be transparent, translucent, or opaque. A patient may prefer a transparent shield when a target in the torso region is being irradiated so as not to feel enclosed. In contrast, a patient may prefer an opaque shield when a target in the head/neck region is being irradiated so as to hide the movement of the source of radiation **24** near the patient's face. The shield can be made from any suitable material. Preferably, the shield is shatterproof and radiation-tolerant. In this regard, a plastic, such as polycarbonate, can be used and even preferred. The shield should be as thin as possible to minimize scatter radiation, which can increase the radiation dose to the skin. Preferably, the thickness of the shield is about 1 mm or less.

[057] The system **20** can further comprise the following components: (v) at least two straight support beams **31**, (vi) an x-ray tube **32**, and (vii) an x-ray detector array **33** as shown in Figs. 11(a) and 11(b). Fig. 11(a) shows a side view of a system **20** in which straight support beams **31** are attached to the globe gantry **21** through a separate axle **36**, which is co-axial with and independent from the axle of the globe gantry **25**, to facilitate on-board imaging, such as 2-D x-ray or 3-D CT imaging, wherein on-board imaging with an x-ray tube **32** and an x-ray detector array **33** is shown. Fig. 11(b) shows the view from the front ring **22** of the globe gantry **21** of a system **20** in which straight support beams **31** are attached to the globe gantry **21** to facilitate on-board imaging with an on-board imaging device **32**, such as 2-D x-ray or 3-D CT imaging, wherein on-board imaging with an x-ray tube **32** and an x-ray detector array **33** is

shown. The array can be one-dimensional or multi-dimensional. The x-ray tube **32** is mounted on at least one straight support beam on one side of the globe gantry. The x-ray detector array **33** is mounted on at least one straight support beam on the opposite side of the globe gantry from the x-ray tube. The two straight support beams are supported at the front end by a bearing mounted on the front ring of the globe gantry and at the rear end by a bearing **36** that is coaxial with, but separate from, the rear rotational axle of the globe gantry. The two straight support beams can rotate independently, i.e., longitudinally independently, of the rotation, i.e., longitudinal rotation, of the globe gantry. The x-ray tube and the x-ray detector array can move along the lengths of the at least two straight support beams **31** to which they are mounted in synchrony. By translating the x-ray tube and detector complex along the straight support arms and rotating around the patient independently of the globe gantry rotation, CT images can be acquired before, during, and after radiation treatment.

[058] The system **20** can further comprise the following component: (viii) a computed tomography (CT) imaging system, a magnetic resonance imaging (MRI) system, or a positron emission tomography (PET)/computed tomography (CT) imaging system positioned adjacent to the front opening ring **22** of the globe gantry **21** as shown in Fig. 12, which illustrates how a three-dimensional imaging device on a ring gantry can be abutted at the front ring **22** of the globe gantry **21** of a system **20** to allow a patient to be imaged and treated while maintaining the same position on a patient platform. The CT imaging system, the MRI system, or the PET/CT imaging system can provide on-board imaging guidance.

[059] Desirably, the same patient platform (**28** or **28** and **29**) is used for imaging and irradiation to minimize geometric uncertainty. Therefore, the patient can be imaged and treated without moving the patient from a fixed position on the patient platform (**28** or **28** and **29**).

[060] A method of irradiating a target in a patient under image guidance using a system **20** as described herein is also provided. The method comprises a) imaging the patient in the treatment position, using the x-ray tube and x-ray detector complex or using the attached or adjacent volumetric imaging systems (CT, MRI, or PET/CT); b) developing a treatment plan to deliver a focal radiation dose by directing intensity-modulated beams of radiation from the external source of radiation at the target in the patient in a

treatment position from numerous directions in a broad solid angle by longitudinally rotating the external source of radiation around a central axis and simultaneously or sequentially, in either order, latitudinally rotating the external source of radiation, while continuously or discontinuously moving the patient; c) delivering the treatment according to the treatment plan with the patient remaining on the patient platform of the same setup as with imaging in a); and d) during radiation treatment, imaging the patient using the x-ray tube and the x-ray detector array mounted on the straight support beams on opposite sides of the patient, wherein, if a change or changes in patient anatomy is/are detected, one or more of the treatment delivery parameters, such as the position of the patient support platform, the shape of the multileaf collimator, the longitudinal and/or latitudinal angle of the beam, and the beam intensity, etc., is/are adjusted such that the external source of radiation is directed at the target in the patient in accordance with the treatment plan.

[061] A treatment plan can be, and desirably is, used to govern the movement of the globe gantry **21**, the source of radiation **24**, and the patient platform **28**. The coordination of all the movements and irradiation is reflected in the treatment plan and executed by the central control unit, which comprises a computer system and interfaced pulse frequency controllers and motion controllers. Such control units are commonly employed in the medical linear accelerators made by skilled artisans in the field. In an embodiment the treatment plan is designed by a treatment planning system that uses 3-D images of the patient and all the freedom provided by the system described herein to determine the best possible dose distribution. The planning procedure can, and typically does, involve computer optimization commonly referred to as "inverse planning." The treatment plan is then digitally transferred to the system **20** and translated to machine control code that drives the delivery of radiation and the movement of different components of the system and the patient support platform.

[062] The system **20** and method can be configured to make stereotactic irradiation devices that are dedicated to a particular disease site. For example, by reducing the radius, R , of the front opening ring **22** of the globe gantry **21**, the resulting system **20** can be used as an irradiation device dedicated for treating head (e.g., brain) and neck tumors as shown in Fig. 7, which illustrates a system **20** configured as a dedicated device for treating the brain and head and neck tumors where the ranges of the

latitudinal angles at the front and rear ends of the globe gantry **21** are highly asymmetric about the transverse plane across the origin of the globe. In this clinical application, most or all beams would be directed from the rear hemisphere of the globe gantry. The smaller radius, R , allows the dose rate to be increased. The ranges of the latitudinal angles of the globe gantry **21** can be smaller than the general purpose systems, for example, from about 40° to about 110° , making most beams aiming from the superior side of the patient. Because the radius is smaller, the globe gantry **21** weighs less, and the supporting structures can be simplified by using, for example, a single, central supporting column **36**. For example, a torque motor **34** with its stator fixed to the support column **36** and its rotor fixed to the rear, rotational axle can be used to drive the longitudinal rotation. One of ordinary skill in the art can use different mechanisms from the torque motor **34** to effect longitudinal rotation. The supporting base **27** below the front opening ring **22** can be eliminated. The rear, stationary housing **26**, which contains the power supply and the controller for the radiation head, can rotate with the globe gantry **21**, thereby eliminating the need for a slip ring for electrically connecting the stationary power supply and controller to the radiation head. The patient naturally looks out the front opening. The latitudinal range can take further advantage of the geometry of the human head such that most or all beams enter from the upper hemisphere of the head, coinciding with the rear end of the globe gantry **21**.

[063] If the front opening ring **22** of the globe gantry **21** is re-oriented and the radius, R , is optionally further reduced, the system **20** can be used for treating cancers in a human breast pendent through an opening in the patient platform **28** as shown in Fig. 8, which illustrates a system configured as a dedicated device for treating cancers in a human breast pendent through an opening in a patient platform **28** positioned above the opening of the globe gantry **21**, the longitudinal axis of rotation of which is substantially vertical or vertical. The patient platform **28** lies above the front opening ring **22** and is supported and driven to make movements in all three directions (i.e., x, y and z axes).

[064] The globe gantries **21** of Figs. 7 and 8 need not be two separate units. Fig. 9 illustrates an embodiment of the globe gantry **21** in which the longitudinal rotational axis can be pivoted between horizontal and vertical positions through the rotation of a pivoting axle **30** supported by two supporting columns **36**. A rear housing **26**, which comprises a source of power, mechanisms for moving components of the globe gantry

21, and controllers for controlling the movement of the components of the globe gantry **21** and the irradiation of the target in the patient, rotates longitudinally along with the globe gantry **21** by the torque motor **34** and pivots between horizontal and vertical positions along with the globe gantry **21**. The ability to pivot the axis of longitudinal rotation allows the head/neck region and the breast, for example, to be treated with a single machine. The structure that supports the longitudinal rotational axle and the rear housing **26**, which contains the power supply and controllers, is attached to a rotatable axle, which is supported, for example, by two supporting columns **36**, which are separated enough for the rear housing **26** to swing in between the supporting columns **36**, thereby allowing the longitudinal axis of the globe gantry **21** to be either horizontal or vertical for treatment of the head/neck and breast, respectively, for example.

[065] The patient can be treated in either "head-in" or "feet-in" orientation. Therefore, the distance from the origin of the sphere (the isocenter) to the very rear end should not need to be substantially more than about 1 meter to allow irradiation of targets throughout the body. Since the use of beam directions substantially parallel to the patient's axis is not desired, the smallest latitudinal angle, ϕ , is about 40° (50° beyond the central transverse plane of the globe gantry). This allows additional space to be made available in the closed, rear end of the globe gantry **21** as shown in Fig. 10, which illustrates an embodiment of the globe gantry **21** in which a recess at the rear end of the globe gantry **21** provides space for a patient's feet when treated in a "feet-in" orientation, such as for treatment of prostate cancer.

[066] The terminology used herein is for the purpose of describing particular embodiments only and is not otherwise intended to be limiting. For example, the terms "front" and "rear" are used for the purpose of describing relative locations and are not intended to limit the orientation of the globe gantry.

[067] All patents, patent application publications, journal articles, textbooks, and other publications mentioned in the specification are indicative of the level of skill of those in the art to which the invention pertains.

[068] The invention illustratively described herein may be suitably practiced in the absence of any element(s) or limitation(s), which is/are not specifically disclosed herein. Thus, for example, each instance herein of any of the terms "comprising", "consisting essentially of", and "consisting of" may be replaced with either of the other two terms. Likewise, the singular forms "a", "an", and "the" include plural references unless the context clearly dictates otherwise. Thus, for example, references to "the method" include one or more methods and/or steps of the type described herein and/or apparent to those ordinarily skilled in the art upon reading the disclosure.

[069] The terms and expressions, which have been employed, are used as terms of description and not of limitation. In this regard, where certain terms are defined and otherwise described or discussed elsewhere herein, all such definitions, descriptions, and discussions are intended to be attributed to such terms. There also is no intention in the use of such terms and expressions of excluding any equivalents of the features shown and described or portions thereof.

[070] It is recognized that various modifications are possible within the scope of the claimed invention. Thus, it should be understood that, although the present invention has been specifically disclosed in the context of preferred embodiments and optional features, those skilled in the art may resort to modifications and variations of the concepts disclosed herein. Such modifications and variations are considered to be within the scope of the invention as defined by the appended claims.

WHAT IS CLAIMED IS:

1. A globe gantry for longitudinally and latitudinally rotating at least one external source of radiation concentrically around an isocenter placed in a target to be irradiated, which globe gantry has a central axis intersecting the isocenter and which comprises the following components:

(i) a front opening ring with its origin on the central axis of the globe gantry,

(ii) at least one arc-shaped, gantry support arm, which has a front end and a rear end and is part of a circle,

(iii) an external source of radiation, which is mounted on at least one arc-shaped, gantry support arm and can move along the arc-shaped, gantry support arm to make latitudinal rotation about the isocenter,

(iv) a rear rotational axle with an axis along the central axis of the globe gantry,

(v) a support base, and

(vi) a rear housing comprising a source of power, mechanisms for moving components of the globe gantry, and controllers for controlling the movement of the components of the globe gantry and the irradiation of the target in the patient, wherein the front opening ring is attached to the front end of the at least one arc-shaped, gantry support arm, wherein the rear rotational axle is attached to the rear end of the at least one arc-shaped, gantry support arm, wherein the front opening ring and the rear rotational axle are supported by the support base and the rear housing, and wherein the front opening ring and the rear rotational axle can rotate around the central axis causing the external source of radiation to rotate longitudinally.

2. The globe gantry of claim 1, further comprising: (vii) a beam stopper, which is mounted on at least one arc-shaped, gantry support arm on the opposite side of the globe gantry from the external source of radiation.

3. The globe gantry of claim 1 or 2, wherein the external source of radiation is a linear accelerator or a radioisotope teletherapy device.

4. The globe gantry of any one of claims 1 to 3, wherein the external source of radiation can move along the length of the at least one arc-shaped, gantry support arm on which it is mounted at a variable speed.

5. The globe gantry of any one of claims 1 to 3, wherein the external source of radiation is fixed on at least one arc-shaped, gantry support arm, and the arc-shaped, gantry support arm and the rear rotational axle are translated to cause the external source of radiation to rotate latitudinally at variable speed.

6. The globe gantry of any one of claims 1 to 5, the orientation of the central axis of which can be changed from horizontal to substantially vertical or vertical, in which case the rear housing can rotate longitudinally and pivot between horizontal and vertical positions along with the globe gantry.

7. The globe gantry of any one of claims 1 to 6, which comprises at least two arc-shaped, gantry support arms, which are separated by longitudinal angles of 180° or at least two pairs of adjacent arc-shaped, gantry support arms, which pairs are separated by longitudinal angles of 180° .

8. A system for irradiating a target in a patient, which system comprises the following components:

(i) the globe gantry of any one of claims 1 to 7,

(ii) a patient platform, which is positioned along the central axis of the globe gantry and which comprises a first end and a second end,

(iii) a patient platform support, which supports the patient platform.

9. The system of claim 8, wherein the system further comprises: (iv) a shield, which separates the patient from the rest of the system.

10. The system of claim 8 or 9, wherein the patient platform can be independently moved in either direction along the length of the patient platform or z-dimension, in either direction along the width of the patient platform or x-dimension, and/or in either direction above or below the patient platform or y-direction, and such movements are in synchrony with the longitudinal and latitudinal rotations of the external source of radiation.

11. The system of any one of claims 8 to 10, the components of which further comprise:

(v) at least two straight support beams,

(vi) an x-ray tube, and

(vii) an x-ray detector array,

wherein the x-ray tube is mounted on at least one straight support beam on one side of the globe gantry, wherein the x-ray detector array is mounted on at least one straight support beam on the opposite side of the globe gantry from the x-ray tube, and can move along the lengths of the at least two straight support beams to which they are mounted, and

wherein the at least two straight support beams are parallel with the central axis of the globe gantry and are supported at the front end by a bearing mounted on the front ring of the globe gantry and at the rear end by a bearing that is coaxial with, but separate from, the rear rotational axle of the globe gantry, so as to rotate independently of the rotation of the globe gantry.

12. The system of claim 11, wherein the x-ray detector array is one-dimensional or multi-dimensional.

13. The system of claim 11 or 12, the components of which further comprise (viii) a computed tomography (CT) imaging system, a magnetic resonance imaging (MRI) system, or a positron emission tomography (PET)/computed tomography (CT) imaging system attached to or positioned adjacent to the front opening ring of the globe gantry, coaxially or non-coaxially, wherein the CT imaging system, the MRI system, or the PET/CT imaging system can provide onboard imaging guidance.

14. Use of the system of any one of claims 8 to 13 for irradiating a target in a patient under imaging guidance.

15. The use of claim 14, wherein treatment delivery parameters are adjustable upon detection of a change or changes in patient anatomy, said parameters comprising position of a patient support platform, shape of a multi-leaf collimator, longitudinal angle of the beam, latitudinal angle of the beam, and beam intensity.

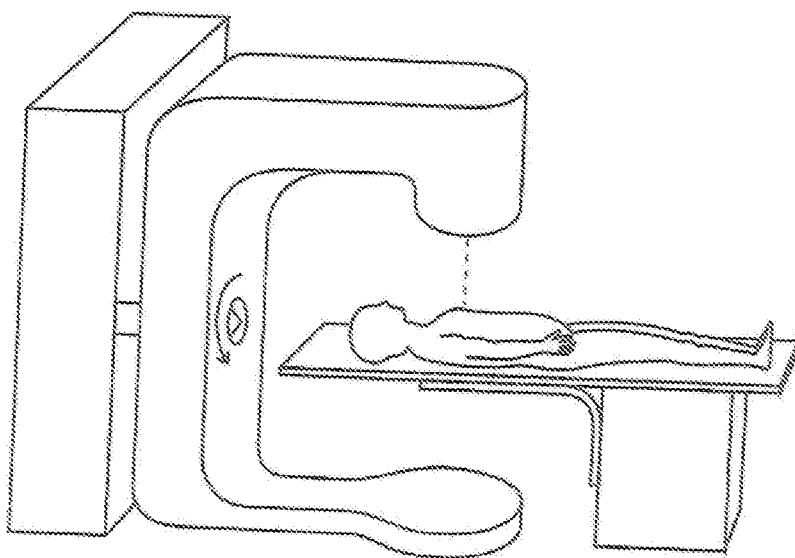

PRIOR ART

Fig. 1

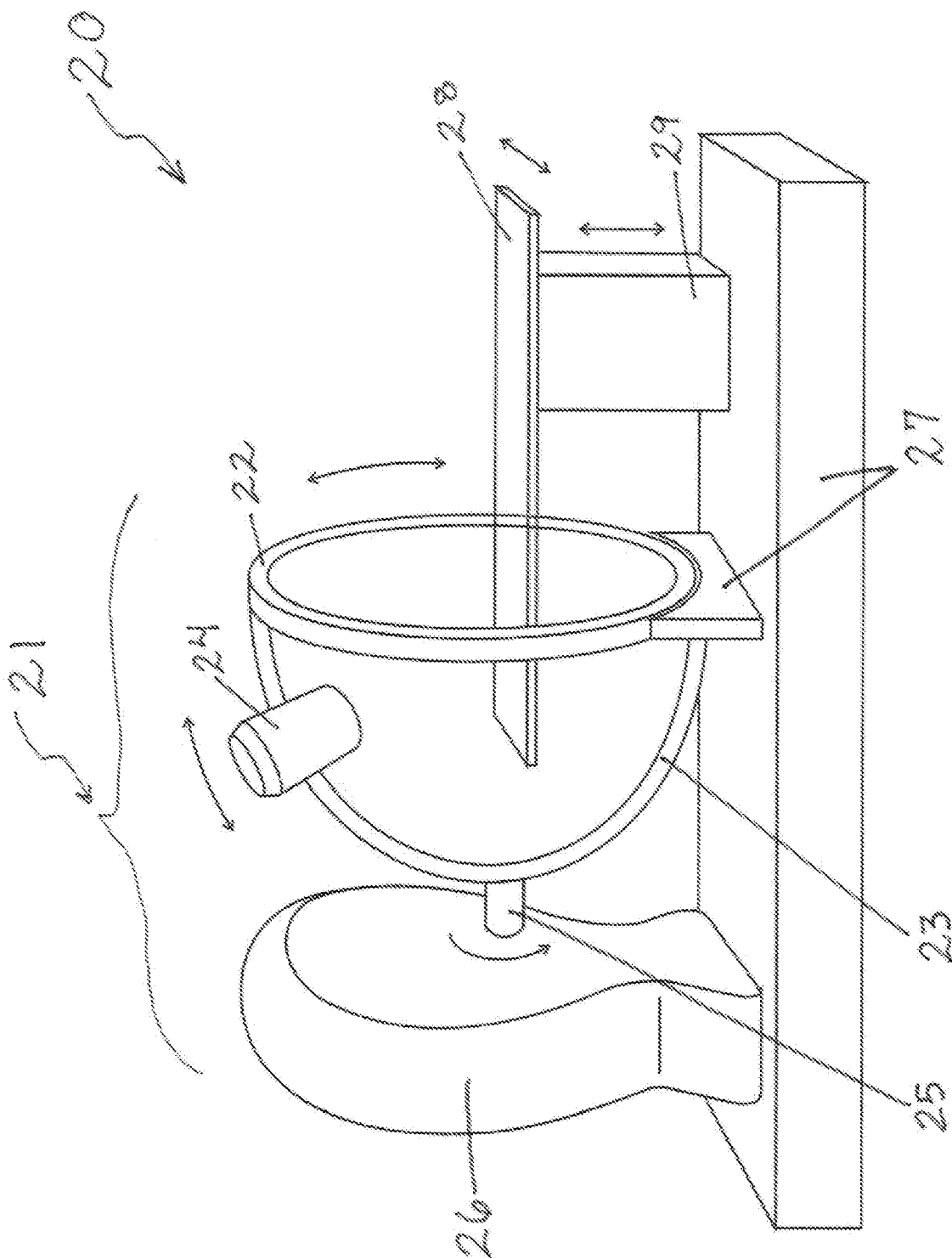

Fig. 2

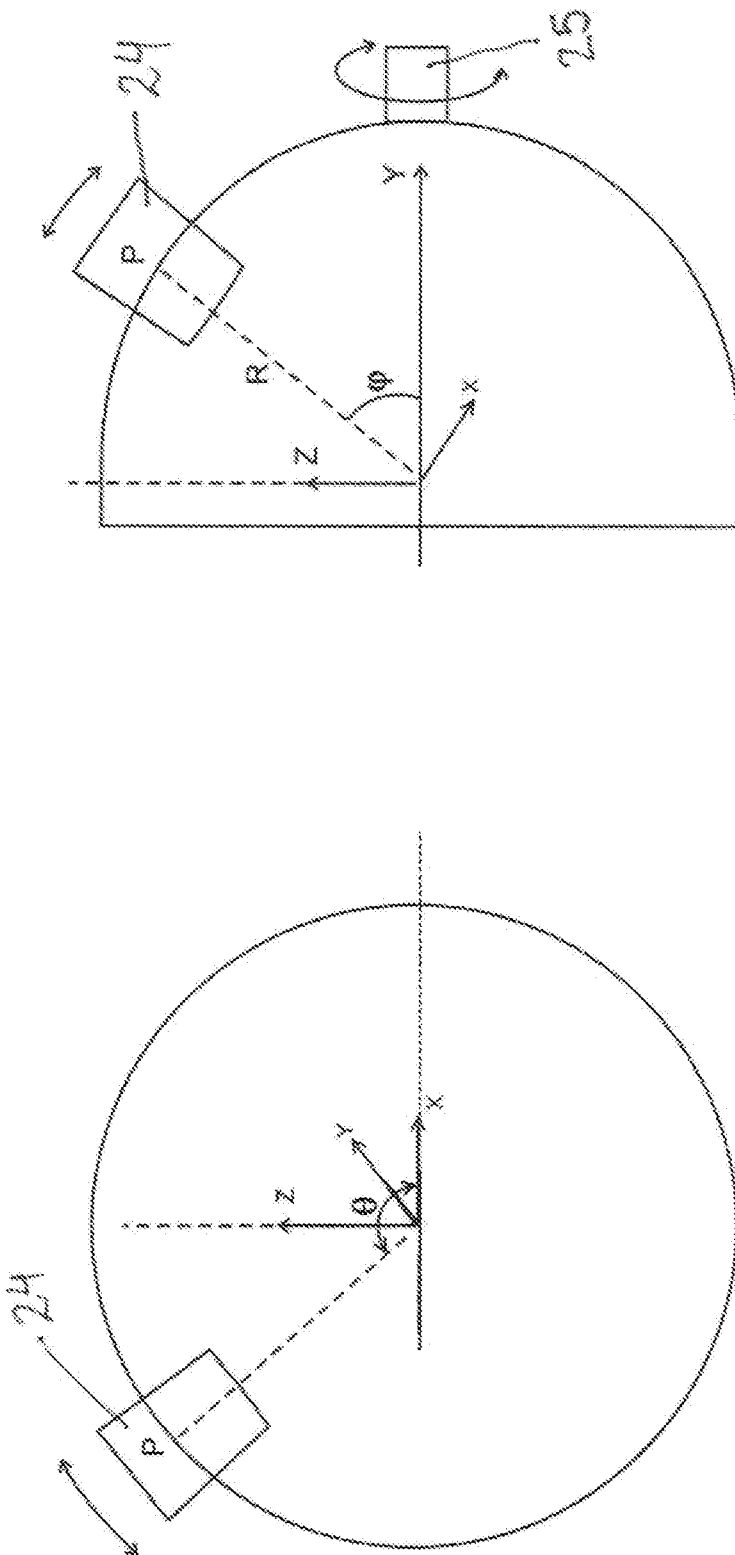

Fig. 3b

Fig. 3a

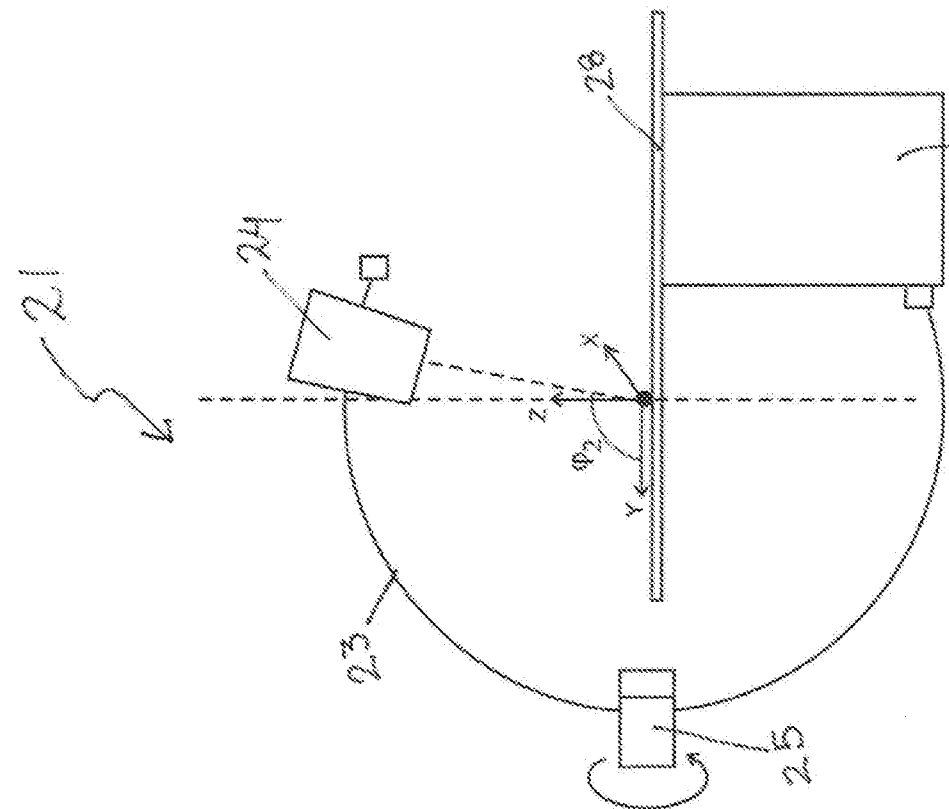

Fig. 4a

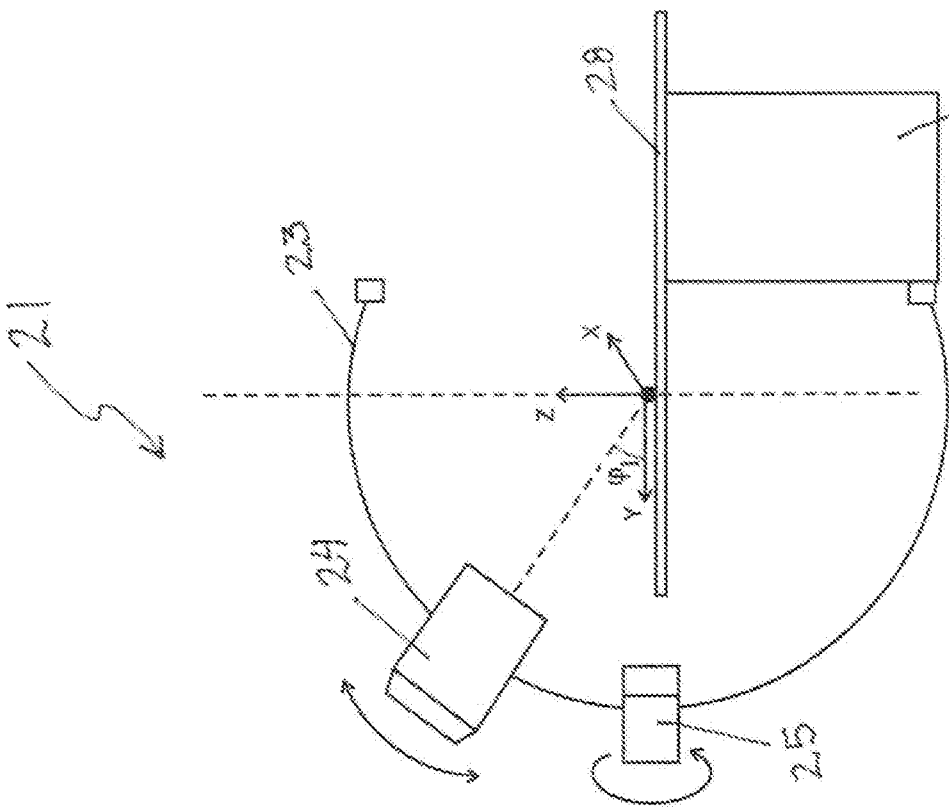

Fig. 4b

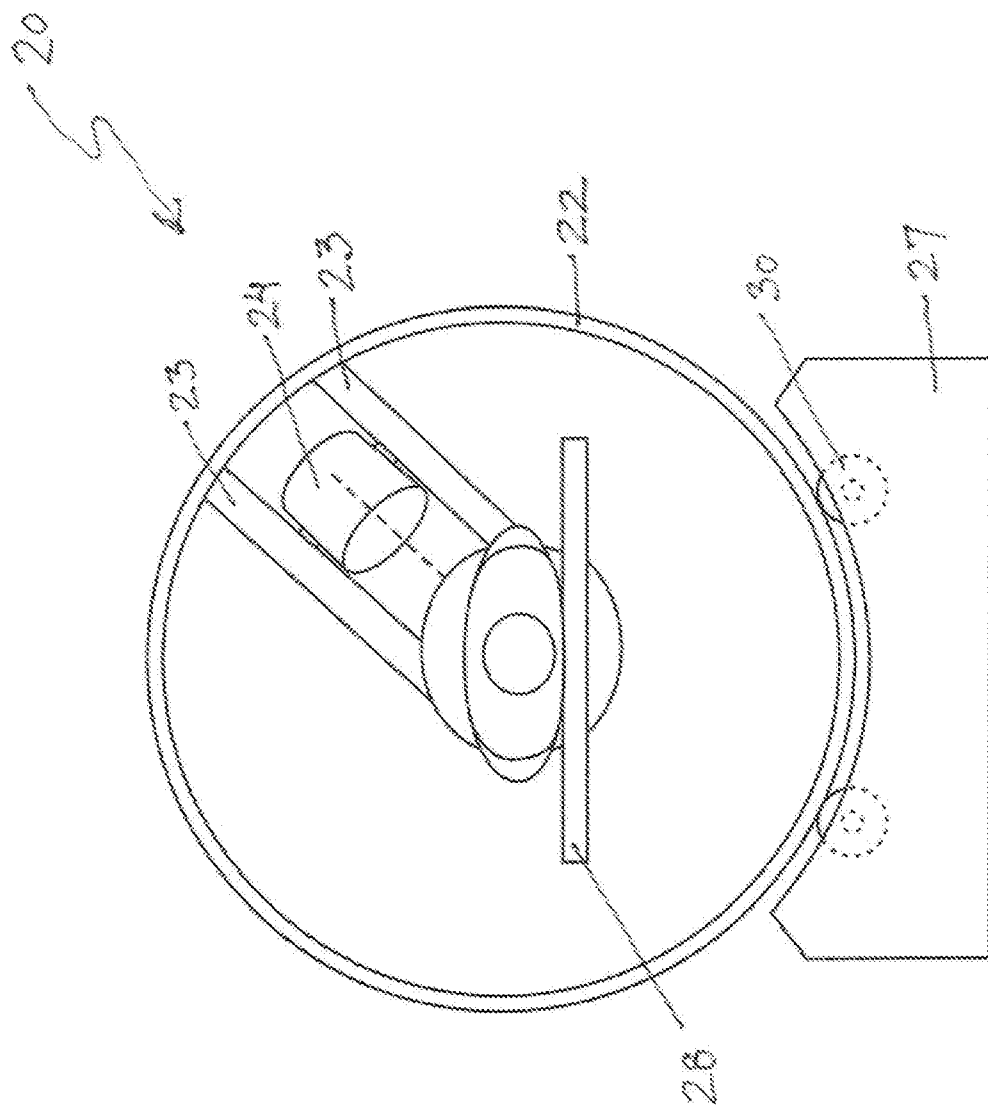

Fig. 5

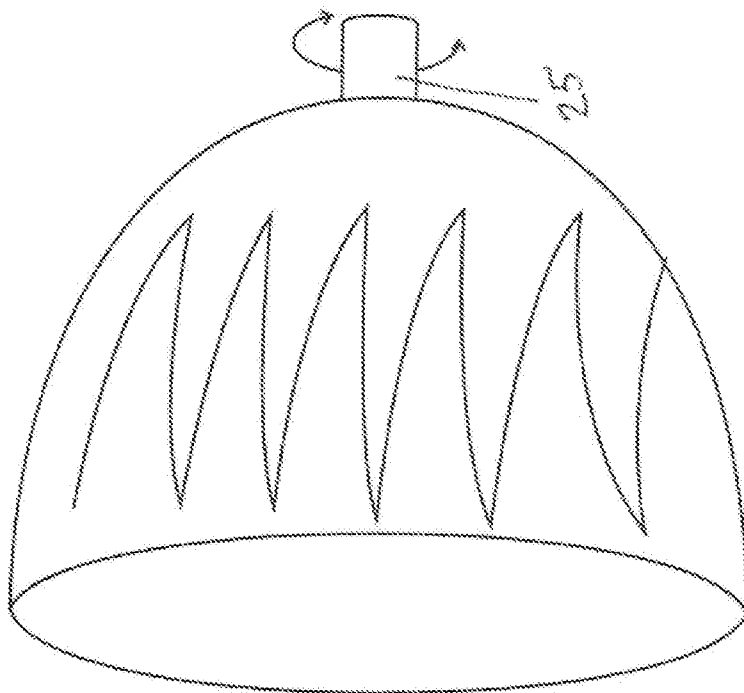

Fig. 6b

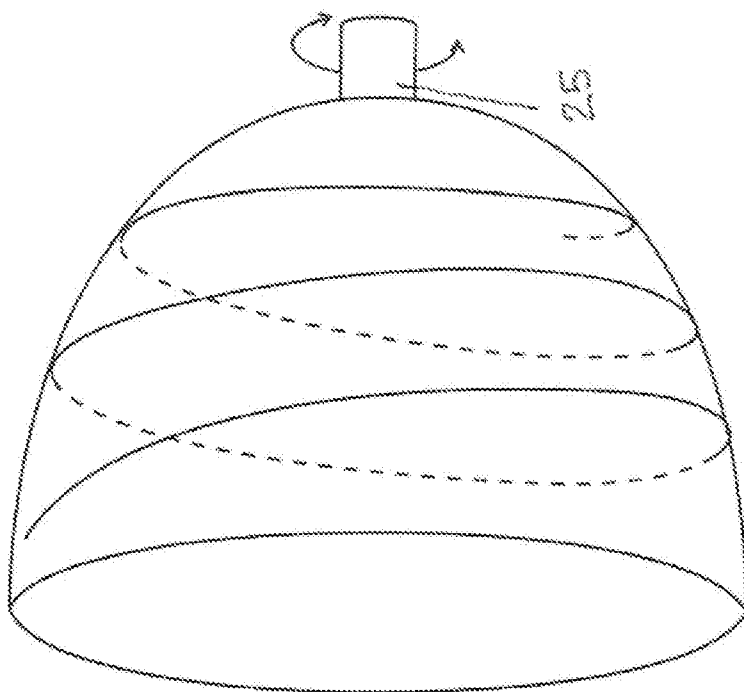

Fig. 6a

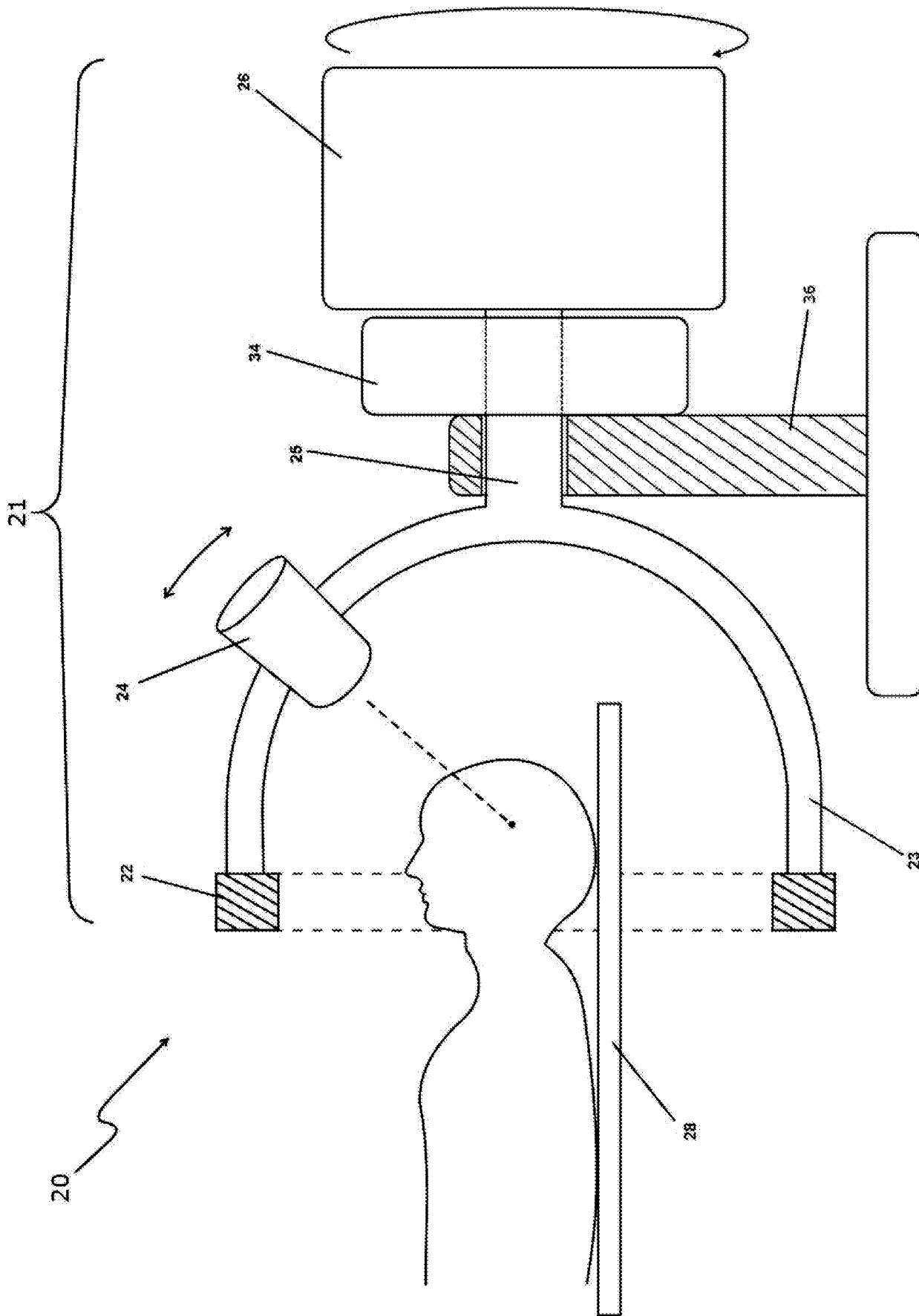

Fig. 7

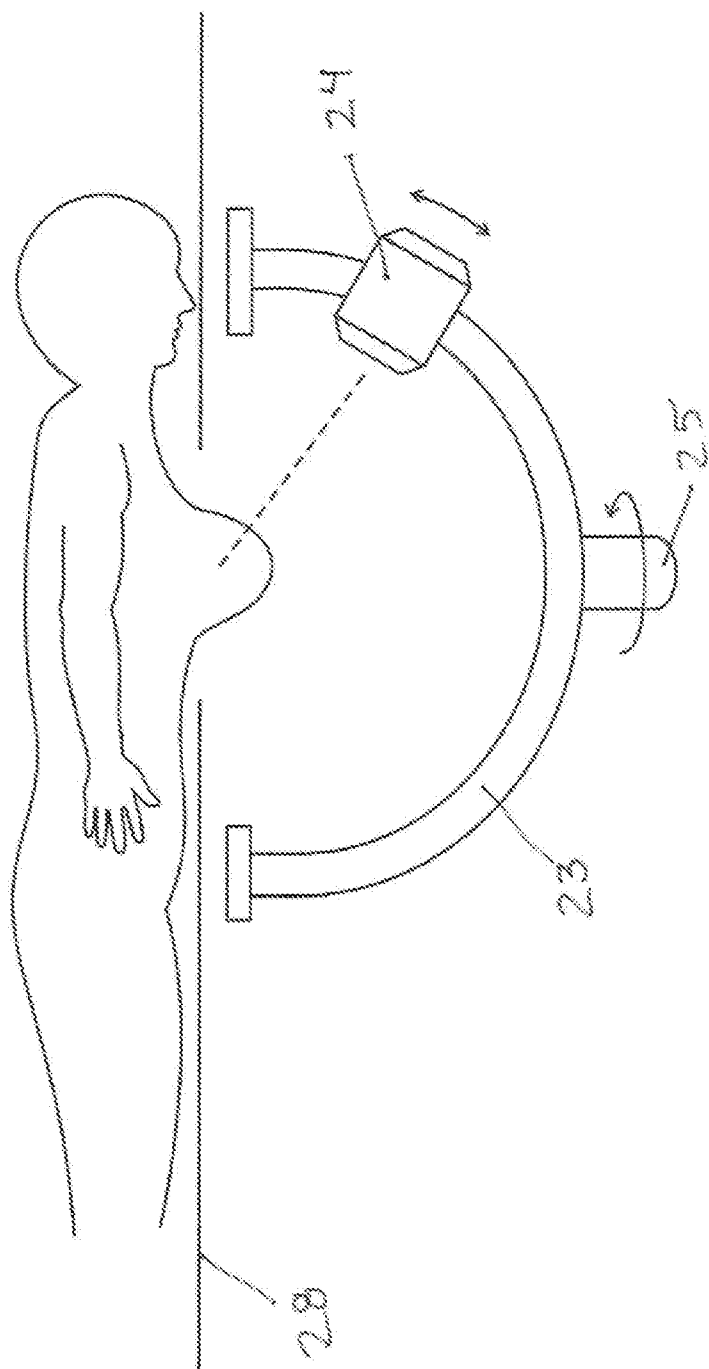
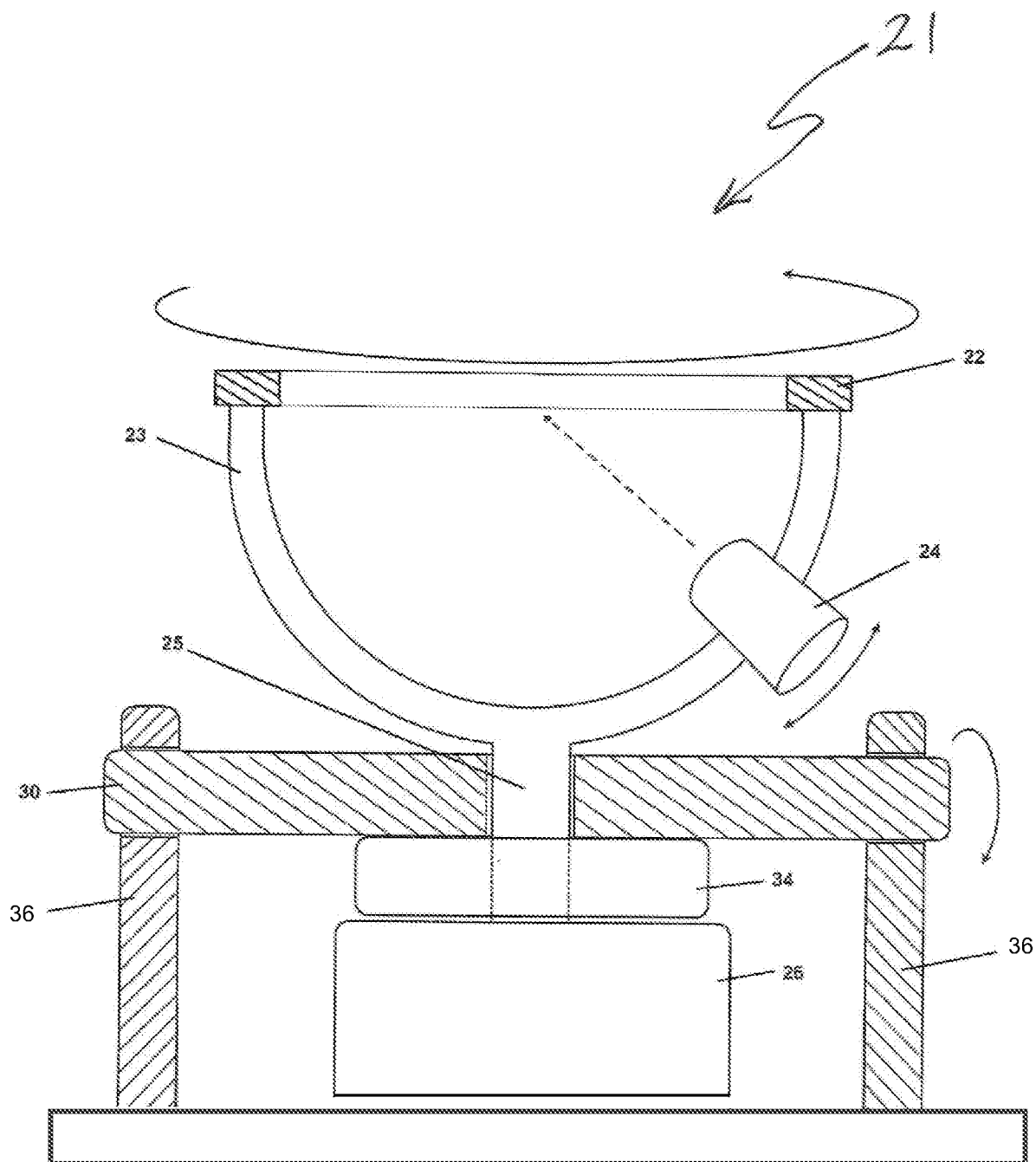

Fig. 8



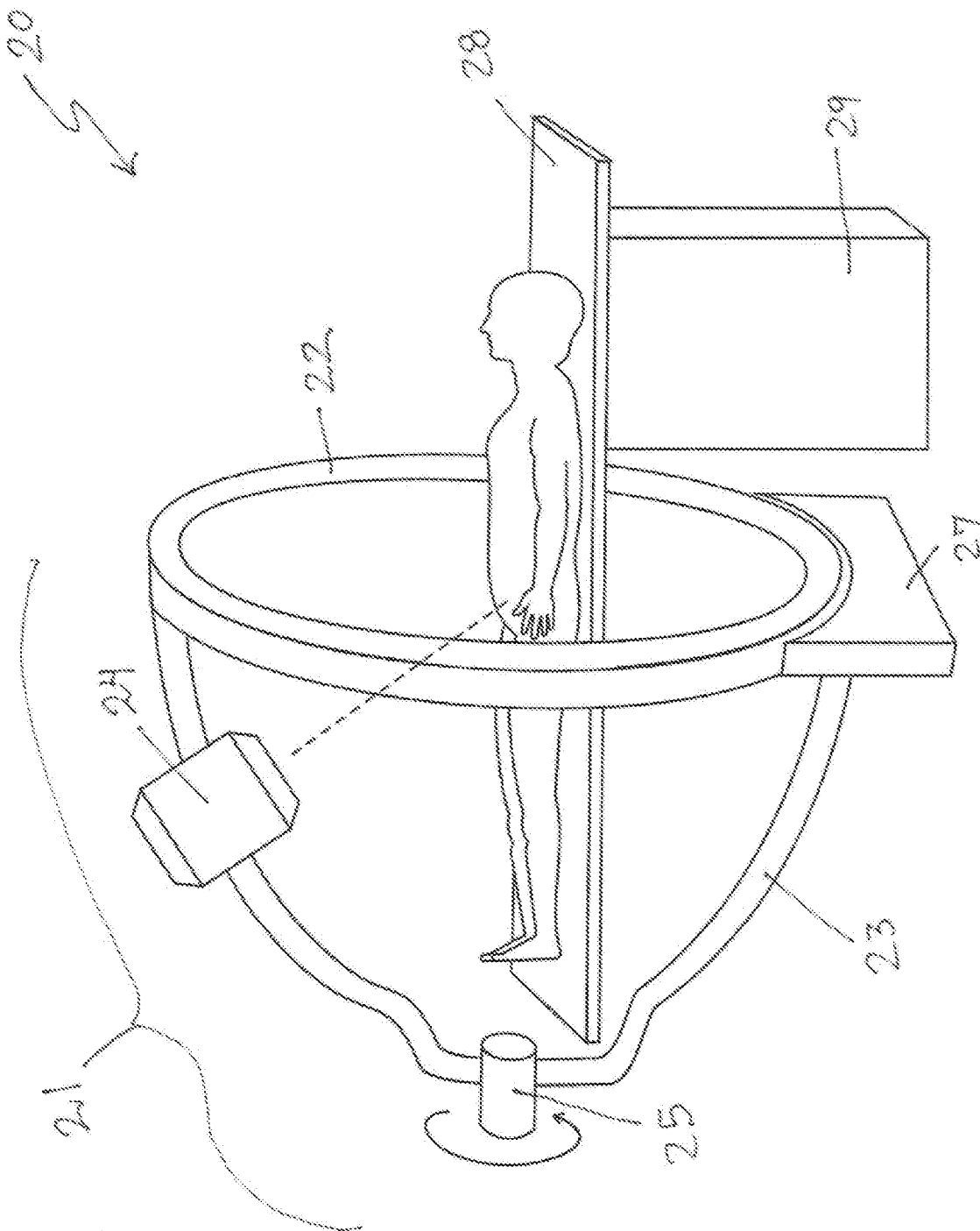

Fig. 10

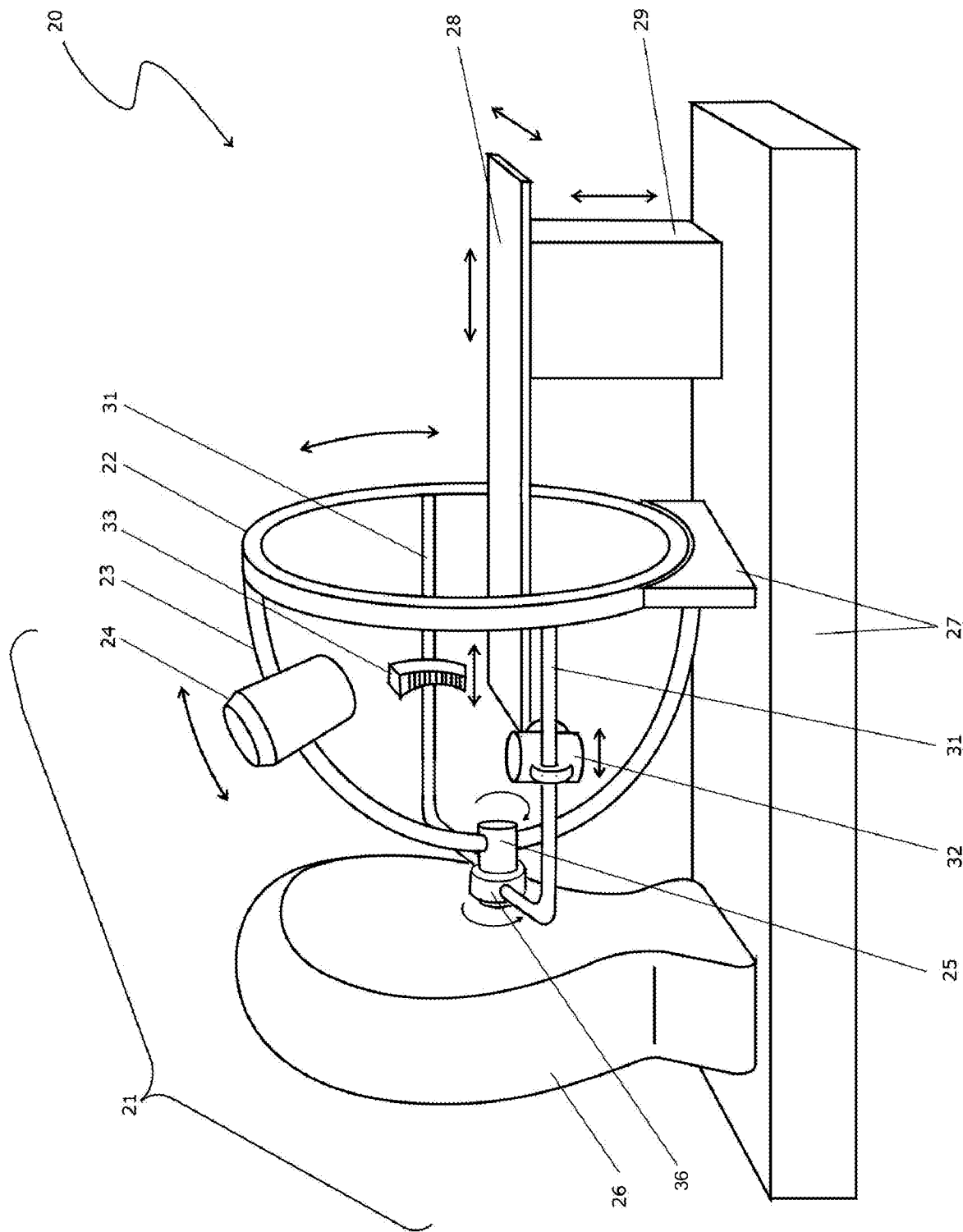

Fig. 11a

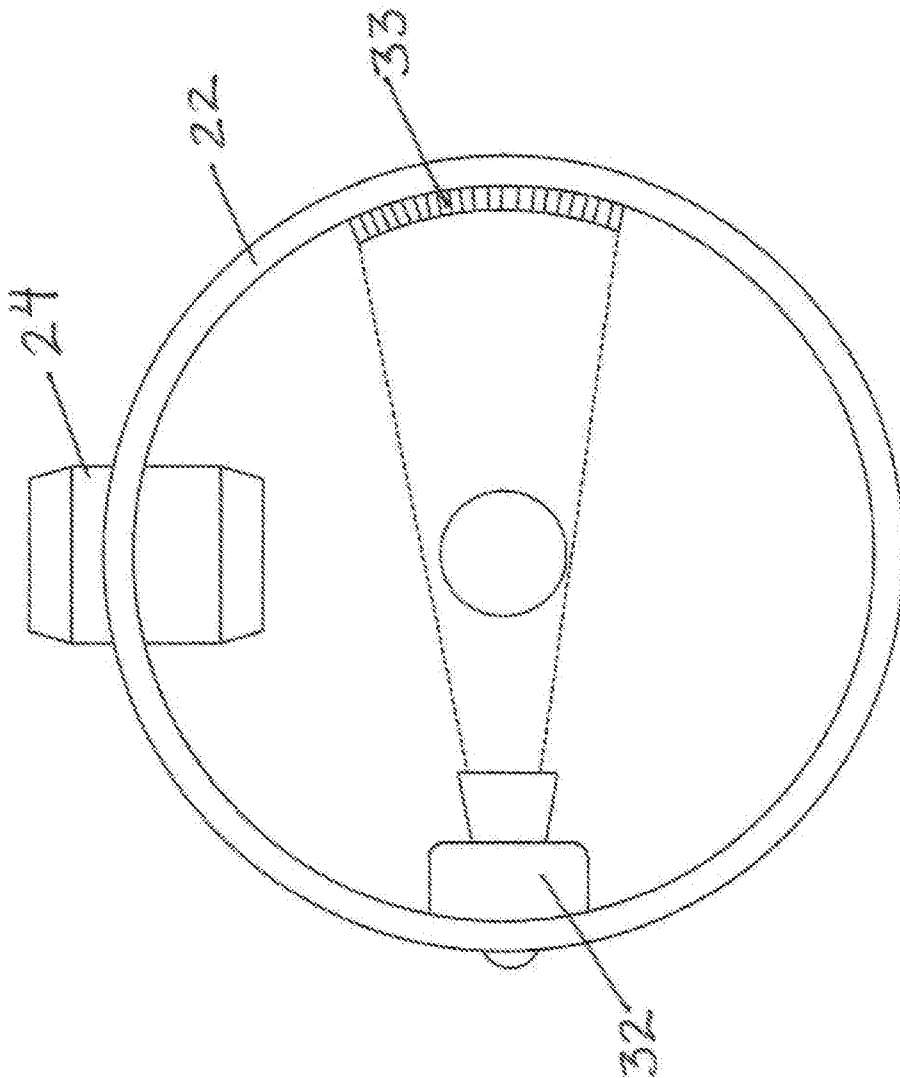

Fig. 11b

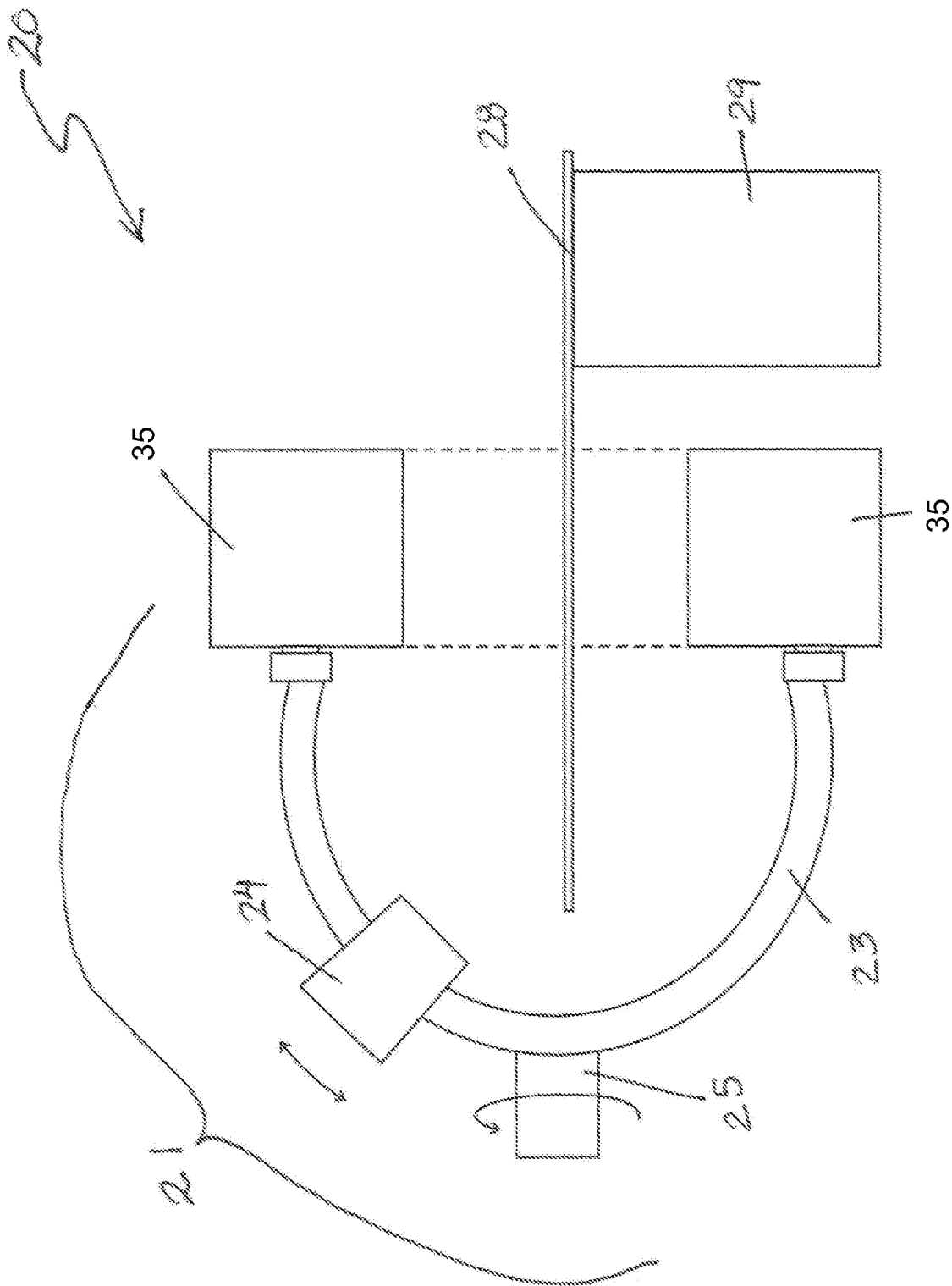

Fig. 12

