

E. S. BOYNTON.
Sewing Machine.

No. 23,285.

Patented March 15, 1859.

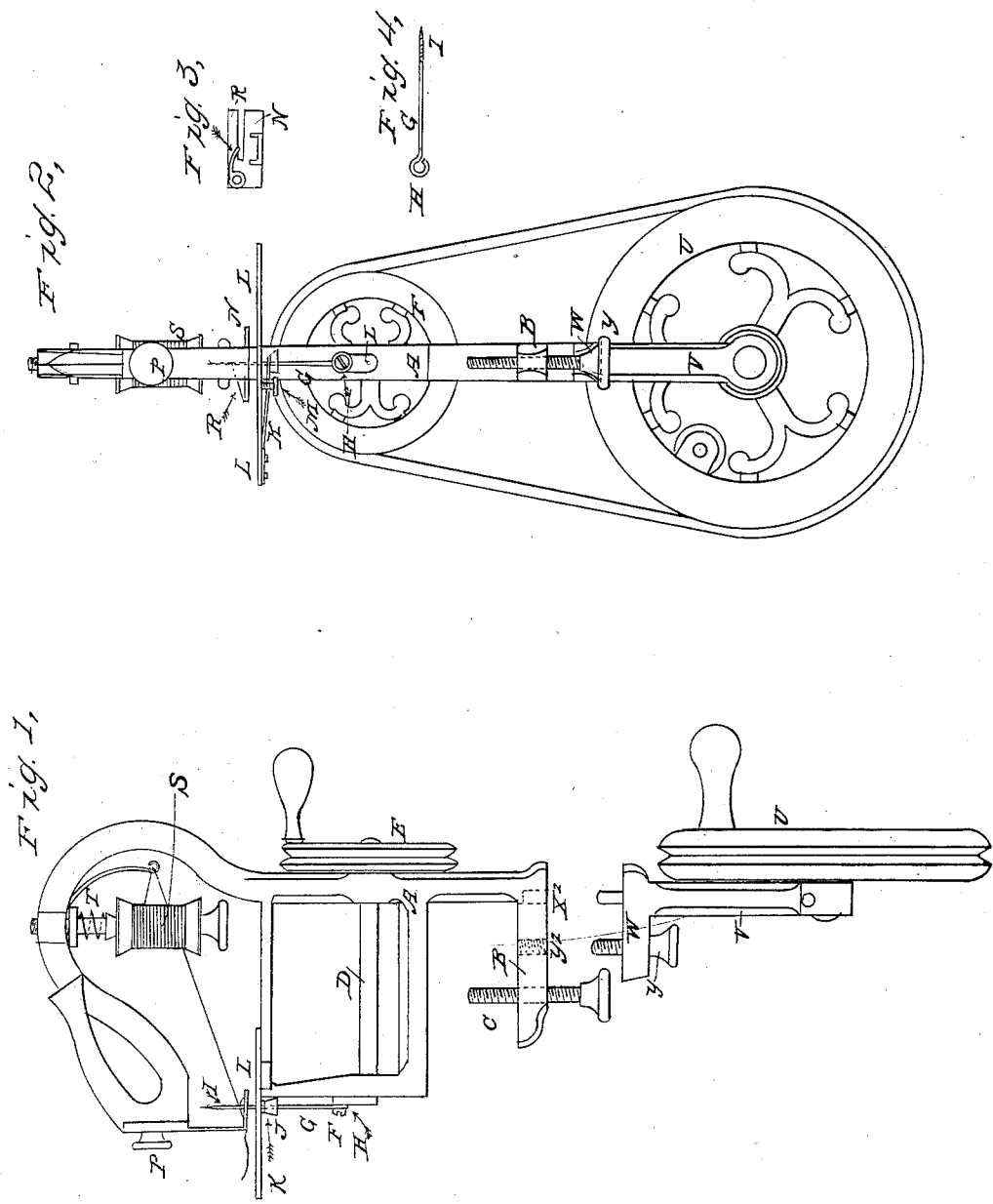

UNITED STATES PATENT OFFICE.

EDWARD S. BOYNTON, OF NEW YORK, N. Y., ASSIGNOR TO PETER R. ROACH, OF ELIZABETH CITY, NEW JERSEY.

IMPROVEMENT IN SEWING-MACHINES.

Specification forming part of Letters Patent No. 23,285, dated March 15, 1859.

To all whom it may concern:

Be it known that I, EDWARD S. BOYNTON, of the city, county, and State of New York, have invented certain Improvements in Sewing Machinery; and I do hereby declare the following to be a full description of the same.

The nature of my improvements consists in the use of the adjustable feed-controlling fulcrum of the needle, in combination with an annular or ring-shaped shanked-wire needle and table of the machine.

But to describe my invention more particularly I will refer to the accompanying drawings, forming a part of this specification, the same letters of reference, wherever they occur, referring to like parts.

Figure 1 is a side elevation of the machine, showing the auxiliary speeder-wheel in position just below it, preparatory to attaching to the frame of the machine. Fig. 2 is a front view of the machine; showing the speeder-wheel attached to the same. Fig. 3 is a plan view of the cloth presser or pad, having a looper-spring attached thereto. Fig. 4 is a representation of the needle.

Letter A is the frame of the machine, having at its lower side a jaw, B, and clamping-screw, C, for the purpose of attaching the machine to the edge of a table, so as to make a portable toilet sewing-machine.

Longitudinally to the frame is secured a crank-shaft, D, which is propelled by a pulley, E, on its back end. To the crank is attached by a pin or screw, F, the shank of a wire needle, G. The mode of attaching the shank of the needle to the crank is by means of an annular or ring-shaped hook, H, formed from the wire constituting the needle by twisting or bending it over a rod of the same diameter as the crank-pin F, and thus adjusting and securing the needle directly upon the crank without the intervention of a needle-bar, as ordinarily used in sewing-machines for adjusting needles. This needle is formed with a barbed eye, I, and is intended to be operated as a self-feeding needle by means of an adjustable fulcrum, J, through which it passes. This fulcrum is formed upon the end of a plate of spring metal, K, secured at its back end to

the under and outer edge of the cloth-plate L. In this spring-metal plate is secured a set-screw, M. The object of this arrangement of the fulcrum is to control and regulate the extent of motion in the point of the needle to feed the cloth, so that by a very simple and easy adjustment of parts the stitch may be graduated to any desired fineness.

Letter N is a cloth-presser, secured upon the front end of the machine-frame by means of a set-screw, P. In this presser is formed a slit, through which the point of the needle passes. On one edge of this slit is secured an elastic wire thread-carrier looper, R. The object of this is to carry the thread across the barb of the needle in its forward and downward motion, to cause it to enter the eye of the needle, and thus be carried down through this cloth.

Letter S is the spool of thread, secured by means of a binding-screw to the frame of the machine, and kept from delivering the thread by tension-springs T for that purpose.

Letter U is an auxiliary speeder-wheel, secured to a suitable post, V, so as to be kept firmly on its axis. Upon the end of this post is a shoulder, W, into which is a pin, X, and a binding or clamping screw, Y, which are made to enter suitable holes, X² and Y², in the lower end of the frame of the sewing-machine in such a way as to bring the speeder-wheel U in a line with the propelling-pulley E, and thus combining an accelerating motion for a portable toilet sewing-machine with but little cost, and at the same time great utility.

Having now described my invention, I will proceed to set forth what I claim and desire to secure by Letters Patent of the United States:

The use of the adjustable fulcrum for controlling the feed of the needle, in combination with an annular or ring-shaped shanked-wire needle as attached directly to the crank-shaft without the intervention of a needle-bar, substantially as hereinbefore set forth.

E. S. BOYNTON.

Witnesses:

GERARD BANCKER,
CHARLES L. BARRETT.