

(12) INTERNATIONAL APPLICATION PUBLISHED UNDER THE PATENT COOPERATION TREATY (PCT)

(19) World Intellectual Property
Organization

International Bureau

(43) International Publication Date
18 October 2018 (18.10.2018)



(10) International Publication Number
WO 2018/189742 A1

(51) International Patent Classification:

A61B 34/20 (2016.01)

(21) International Application Number:

PCT/IL2018/050415

(22) International Filing Date:

11 April 2018 (11.04.2018)

(25) Filing Language:

English

(26) Publication Language:

English

(30) Priority Data:

62/485,267 13 April 2017 (13.04.2017) US

(71) Applicant: **V.T.M. (VIRTUAL TAPE MEASURE) TECHNOLOGIES LTD.** [IL/IL]; 22 Bareket Street, North Industrial Park, Caesarea, P.O. Box 474, 3033509 Atlit (IL).

(72) Inventor: **SIDLESKY, Avishay**; 18 Nahal Barkan, P.O. Box 474, 3033509 Atlit (IL).

(74) Agent: **LUZZATTO-SHUKRUN, Lilach** et al.; Luzzatto & Luzzatto, P.O. Box 5352, 8415202 Beer Sheva (IL).

(81) Designated States (*unless otherwise indicated, for every kind of national protection available*): AE, AG, AL, AM, AO, AT, AU, AZ, BA, BB, BG, BH, BN, BR, BW, BY, BZ, CA, CH, CL, CN, CO, CR, CU, CZ, DE, DJ, DK, DM, DO, DZ, EC, EE, EG, ES, FI, GB, GD, GE, GH, GM, GT, HN, HR, HU, ID, IL, IN, IR, IS, JO, JP, KE, KG, KH, KN, KP, KR, KW, KZ, LA, LC, LK, LR, LS, LU, LY, MA, MD, ME, MG, MK, MN, MW, MX, MY, MZ, NA, NG, NI, NO, NZ, OM, PA, PE, PG, PH, PL, PT, QA, RO, RS, RU, RW, SA, SC, SD, SE, SG, SK, SL, SM, ST, SV, SY, TH, TJ, TM, TN, TR, TT, TZ, UA, UG, US, UZ, VC, VN, ZA, ZM, ZW.

(84) Designated States (*unless otherwise indicated, for every kind of regional protection available*): ARIPO (BW, GH, GM, KE, LR, LS, MW, MZ, NA, RW, SD, SL, ST, SZ, TZ, UG, ZM, ZW), Eurasian (AM, AZ, BY, KG, KZ, RU, TJ, TM), European (AL, AT, BE, BG, CH, CY, CZ, DE, DK, EE, ES, FI, FR, GB, GR, HR, HU, IE, IS, IT, LT, LU, LV, MC, MK, MT, NL, NO, PL, PT, RO, RS, SE, SI, SK, SM, TR), OAPI (BF, BJ, CF, CG, CI, CM, GA, GN, GQ, GW, KM, ML, MR, NE, SN, TD, TG).

Declarations under Rule 4.17:

— *of inventorship (Rule 4.17(iv))*

Published:

— *with international search report (Art. 21(3))*

(54) Title: ENDOSCOPIC MEASUREMENT METHODS AND TOOLS

(57) Abstract: Presented are methods for determining the position and orientation of medical tools inserted through a working channel of an endoscopic device or through a trocar and visible in images gathered by the visualization systems and methods for conducting measurements with said tools.



WO 2018/189742 A1

ENDOSCOPIC MEASUREMENT METHODS AND TOOLS

5 Field of the Invention

The invention is from the field of medical devices. Specifically the invention relates to endoscopic devices comprising visualization systems. More specifically the invention relates to methods for determining the position and orientation of medical tools inserted through a working channel of the
10 endoscopic device or through a trocar and visible in images gathered by the visualization systems and methods for conducting measurements with said tools.

Background of the Invention

15 When using a camera equipped borescope to inspect engines or machined parts for imperfections of interior surfaces, it would be advantageous to be able to perform and record accurate, three-dimensional measurements to obtain the dimensions of the imperfections in order to be able to evaluate the extent of the damage and to determine what corrective measures should
20 be taken.

During endoscopic medical procedures, it is of an advantage to perform accurate three dimensional measurements to obtain dimensions of anatomical structures within the lumen, such as lesions, stenoses, tumors,
25 and the like. Tracking such measurements along time may further improve the level of care provided.

Currently, physicians using a state of the art endoscope, be it flexible or rigid, monocular or stereoscopic, do not have a true volumetric perspective
30 within the acquired image and are unable to conduct accurate measurements. A common practice is to place a tool of known size (e.g., a

- 2 -

catheter with known diameter) next to the anatomical structure and use it as a scale to assess dimensions. Because the tool is being freely manipulated by hand distortions in the images that affect the accuracy of the measurements such as foreshortening take place.

5

In US 9,545,220 the inventor of the present invention disclosed a system and method for measuring 3D distances and dimensions of objects in endoscopic images by using a light plane to make Euclidean and geodesic measurements. The endoscopic measurement system of the invention
10 comprises a flexible or rigid endoscopic device equipped with standard visualization systems and a module containing components for generating a light plane. Based on triangulation, the intersection curve between the light plane and the object of interest is measureable in 3D in the coordinate system of the visualization systems.

15

In US 9,545,220 embodiments are described in which the light plane generating module can be provided as either a dedicated component of an endoscopic device or as an add-on unit that can be attached and detached from an endoscopic device. To enable correction for distortions and insure
20 accurate measurements calibration must be carried out to know the location and orientation of the light plane relative to the focal point of the camera. For the dedicated embodiment the calibration is carried out in the factory during manufacture of the device. For the add-on embodiment a calibration is made before each procedure, which can be carried out automatically with
25 a docking station, which is described therein.

In US 9,545,220 a third embodiment is mentioned in which the light plane generating module is inserted through the working channel of an endoscopic device and manually manipulated. In this implementation the light plane
30 position and orientation (pose) cannot be pre-calculated, therefore

- 3 -

measurements made with this embodiment suffer from the same sources of inaccuracy as those described above for other diagnostic and surgical tools inserted through working channels. This also applies to tools inserted through trocars, typically used in laparoscopic surgery.

5

It is therefore a purpose of the present invention to provide a method for determining the position and orientation of a manually-operated tool in an endoscopic image.

10 It is another purpose of the present invention to provide a method for determining the position and orientation and providing visual feedback for adequate positioning of a manually-operated light plane endoscopic measurement tool.

15 It is another purpose of the present invention to provide medical tools comprising integrated light plane measurement capabilities for insertion through working channels of endoscopic devices and through trocars.

Further purposes and advantages of this invention will appear as the
20 description proceeds.

Summary of the Invention

In a first aspect the invention is a method of determining the position and orientation of a manually-operated endoscopic tool relative to a camera focal
25 point in an endoscopic image. The method comprises:

- a) identifying in the image features on the tip of the tool, wherein the features are at least one of salient features of the tip of the tool or features of an imprinted or engraved pose pattern created on the surface of the tip; and

- 4 -

b) using a method of camera pose estimation to determine the position and orientation of the features in a 3D camera coordinate system, and therefore the position and orientation of the tool itself.

5 In embodiments of the method of the first aspect the method of camera pose estimation is the Perspective-n-Point method, for the case of three feature points or more.

In embodiments of the method of the first aspect the tool is a light plane
10 generating module.

In a second aspect the invention is a method of using a manually-operated tool introduced to a site inside a lumen of a body through a working channel of an endoscopic device or through a trocar to make accurate estimates of
15 the dimensions of an object seen in images taken by an endoscopic camera. The method comprises:

a) placing the tool next to the objects;
b) providing a processor device and software configured to analyze the camera images in order to:

20 i) identifying in the image features on the tip of the tool, wherein the features are at least one of salient features of the tip of the tool or features of an imprinted or engraved pose pattern created on the surface of the tip;

25 ii) using a method of camera pose estimation to determine the position and orientation of the features in a 3D camera coordinate system, and therefore the position and orientation of the tool itself; and

30 iii) using augmented reality techniques to superimpose on the camera image a virtual ruler at the tip of the tool in contact with the object to obtain accurate estimates of the dimensions of the object.

- 5 -

In a third aspect the invention is a method of using a manually-operated light plane generating module introduced to a site inside a lumen of a body through a working channel of an endoscopic device or through a trocar to make accurate measurements of the dimensions of an object seen in images taken by an endoscopic camera. The method comprises:

a) providing the light plane generating module with distinctive features, wherein the features are at least one of salient features of the light plane generating module or features of an imprinted or engraved pose pattern created on its surface;

b) introducing the light plane generating module until its tip is visible in the endoscopic image;

c) aligning the light plane across the object to be measured;

d) providing a processor device and software configured to analyze the camera images in order to:

i) identify in the image features on the tip of the light plane generating module, wherein the features are at least one of salient features of the tip of the tool or features of an imprinted or engraved pose pattern created on the surface of the tip;

ii) use a method of camera pose estimation to determine the position and orientation of the features in a 3D camera coordinate system, and therefore the position and orientation of the light plane generating module and the offset of the light plane from the camera focal point in the 3D camera coordinate system;

iii) determine the exact coordinates in the 3D camera coordinate system of pixels on the curves formed by intersection of the light plane with the object; and

iv) use the known 3D camera coordinates of pixels in the image to determine the actual dimensions of the object.

In embodiments of the method of the third aspect augmented reality techniques are used to superimpose on the camera image a virtual tape

- 6 -

measure with ticks along the intersection curves to assist in the visualization of the measurements.

In embodiments of the method of the third aspect the processor device and software are configured to determine the offset of the light plane from the camera focal point and to provide audible or visual feedback for adequate positioning of a manually-operated endoscopic light plane measurement tool. In these embodiments feedback for adequate positioning of the light plane can be provided to the operator in at least one of the following ways:

- 10 a) the measurement process is disabled and an audible signal and or a visual message on the display is sent to the operator indicating that the measurement cannot be performed because features are not visible or the offset is below a predetermined threshold;
- b) textual or audible messages indicating the expected accuracy; and
- 15 c) color-coding the display to notify the user of the accuracy of the measurement.

In a fourth aspect the invention is a diagnostic or therapeutic endoscopic tool comprising an attached light plane generating module to provide the tool with integrated light plane measurement capabilities. In embodiments of the diagnostic or therapeutic endoscopic tool the light plane generating module is attached to the tool in one of the following ways: externally, embedded, and completely integrated.

25 All the above and other characteristics and advantages of the invention will be further understood through the following illustrative and non-limitative description of embodiments thereof, with reference to the appended drawings.

Brief Description of the Drawings

- Fig. 1A schematically shows an image gathered by a camera on the endoscope of a biopsy forceps in contact with a polyp;
- Fig. 1B schematically shows the image of Fig. 1A with a virtual ruler superimposed at the tip of the biopsy forceps;
- 5 — Fig. 2 shows an image of a human larynx imaged using a standard endoscopic visualization system with superimposed features pertaining to the light plane;
- Fig. 3 is a schematic illustration of a specific embodiment of the system of the invention in which a separate processing station is included;
- 10 — Fig. 4 schematically shows a light plane generating module rigidly attached to a biopsy forceps;
- Fig. 5 schematically shows a light plane generating module rigidly attached to the over-tube of a snare;
- 15 — Fig. 6A schematically shows an image gathered by a camera on the endoscope of a tip of a manually-operated light plane generating module in front of a polyp;
- Fig. 6B schematically shows the image of Fig. 6A with a virtual tape measure superimposed on the intersection curves between the light plane and the objects in the scene; and
- 20 — Fig. 6C is the same as Fig. 6A with the exception of the pose pattern on the tip of the tool.

Detailed Description of Embodiments of the Invention

- 25 It is noted that the terms “endoscope” and “endoscopic device” are used herein in a generic sense to apply to endoscopes, catheters, laparoscopes, and similar instruments used in medical applications and also to borescopes and similar instruments used in non-medical applications. Since the word endoscope is usually associated with medical applications, the invention will
- 30 be described herein in terms of medical endoscopes and procedures but it is

- 8 -

to be understood that all of the description and examples given herein apply *mutandis mutatis* to non-medical endoscopic devices and procedures.

Endoscopic tools are typically introduced to an observation or operating site
5 inside a body lumen through a working channel of an endoscopic device or
through a trocar. In order to determine in an endoscopic image the position
and orientation of endoscopic tools relative to the camera focal point, it is
essential that easily identifiable features on the tip of the tool should be
10 visible in the endoscopic image. The features can either be salient features
of the tip of the tool or features of an imprinted or engraved pose pattern
created on the surface of the tip to facilitate detection.

Fig. 1A schematically shows an image gathered by a camera on the
endoscope of a biopsy forceps in front of a polyp. Seen in the figure are
15 biopsy forceps 110 on which a pose pattern 112 has been created, and a
polyp 114. It is typically convenient to identify the corners of the pattern as
feature points.

If the features that are visible in the image are points, then the Perspective-
20 n-Point method or similar approaches known in the art of camera pose
estimation is used to determine their position and orientation in the 3D
camera coordinate system, and therefore the position and orientation of the
tool itself. Three feature points are used as a minimum, while in practice a
fourth feature point and more are used to resolve ambiguity.

25

Any tool that can be introduced to a site inside a lumen of the body through
a working channel of an endoscopic device or through a trocar, e. g. forceps,
snare, laser, cautery tool, and grasper, can be used to make accurate
estimates of the dimensions of objects seen in images taken by the
30 endoscope camera by following the common practice of placing the tool next
to the anatomical structure, carrying out the simple procedure above, and

- 9 -

providing a processor device and software to analyze the camera images, identify the features and solve the equations of the method used to determine the position and orientation of the tool in the 3D camera coordinate system. Once the position and orientation of the tool in the 3D camera coordinate system is known augmented reality techniques are used to superimpose on the camera image a virtual ruler **126** at the tip of the tool in contact with the object to provide a local scale and more accurate estimates of the dimensions of the object as shown in Fig. 1B.

10 The method and system described in US 9,545,220 take a simplified approach to solving the problem of measuring, rather than estimating, 3D distances and dimensions of objects in endoscopic images by using a light plane to make linear and geodesic measurements. The endoscopic measurement system of the invention comprises a flexible or rigid endoscopic device equipped with standard endoscopic visualization systems, e.g. a camera, a processing station and components for generating a light plane. Based on triangulation, the intersection curve in an endoscopic image between the light plane and the object of interest is measureable in 3D in the camera coordinate system, much like using an actual tape measure.

20

Fig. 2 taken from US 9,545,220 shows an image of a human larynx imaged using a standard endoscope. In this image a light plane, is represented by a superimposed reticle **2**, the intersection curves of the light plane with the larynx **4**, and a measurement of the opening of the vocal cords **6** are schematically illustrated.

25

Fig. 3 also taken from US 9,545,220 is a schematic illustration of a specific embodiment of the system of the invention in which a separate processing station is included. The system comprises an endoscopic device that comprises standard endoscopic visualization systems (e.g. a camera) and a

30

- 10 -

light plane generating module 12 attached to the distal end of the endoscopic device 22 and a processing station 10 comprising a processor device 14 that acquires the images from the conventional endoscopy system used to operate the endoscope, and a display 16. Processor device 14 can be, for example, a PC or laptop computer or a Field-Programmable Gate Array or Digital Signal Processor microcontroller. Processor device 14 comprises a dedicated software module that assigns 3D coordinates to each pixel along the intersection curves, a pointing device, and an additional software module implementing a GUI for taking both linear and geodesic measurements at user specified locations. Display 16 presents the images, overlaid graphics and text to the user of the system. The additional software module includes an automatic mode to measure holes or gaps or the diameter of polyps either automatically detected or pointed at by the user on an image displayed on display 16. Also shown in Fig. 3 as components of processing station 10 are cable 34 that transfers images from the conventional endoscopy system connected to the endoscopic device to the processor device 14 and mouse 36, which symbolically represents the pointing device and input devices for user input to the processing station.

In the system illustrated in Fig. 3 the light plane generating module is rigidly attached to the endoscope either as an integrated component or as an add-on unit. In either case the accuracy of the measurements carried out using the light plane is insured by carrying out a calibration procedure as discussed herein above and described in greater detail in US 9,545,220.

25

Fig. 6A and Fig. 6C schematically illustrate the present invention in which the light plane generating module 118 is a manually-operated tool introduced through a working channel or a trocar like any other endoscopic tool until its tip is visible in the endoscopic image. Therefore, before the measurements are made, the procedure described herein above is carried out using the pose pattern 112 to determine the position and orientation of

30

- 11 -

the light plane in the coordinate system of the camera in the same way as for any other endoscopic tool as described herein above. In Fig. 6A the pose pattern is composed of two squares. In Fig. 6C the pose pattern is a U-shaped line engraved about the edges of the distal end of the tool. In the case of a light plane generating module however the tool is not in contact with the object, e.g. polyp 114, and no virtual ruler is needed to assess dimensions since the exact coordinates in the 3D camera coordinate system of every pixel on the curves 116 formed by intersection of the light plane with the object are known, which allows accurate measurements to be taken. Once the position and orientation of the manually-operated light plane generating module tool in the 3D camera coordinate system are known augmented reality techniques can be used to superimpose on the camera image a virtual tape measure 128 with ticks along the intersection curves to assist in the visualization of the measurements as shown in Fig. 6B.

The accuracy of a light plane measurement device is dependent on the offset between the light plane and the camera focal point, i.e. if the offset is zero the dimensions cannot be measured and the larger the offset the greater the accuracy. Therefore software in the processor device of the system is configured to determine the position and orientation of the light plane in the 3D camera coordinate system and the offset of the light plane from the camera focal point. The system is also configured to provide audible or visual feedback for adequate positioning of a manually-operated endoscopic light plane measurement tool.

Feedback for adequate positioning can be provided to the operator in several ways, for example:

- If not all features are visible such that the measurement cannot be performed or if the offset is below a predetermined threshold then the

- 12 -

system is configured to disable the measurement process and send an audible signal and or a visual message on the display.

- Provide textual messages indicating whether or not a measurement may be taken, and the expected accuracy.

5 ○ Color-code the display to notify the user of the accuracy of the measurement. In one exemplary embodiment, Red indicates inability to perform measurement, Orange indicates limited accuracy, Yellow indicates adequate accuracy and Green indicates high accuracy.

10 Because it is of clinical benefit to accurately measure the size of an object while its histopathology is determined (either in-situ or in the lab) another aspect of the present invention is to integrate light plane measurement capabilities into diagnostic or therapeutic endoscopic tool, such as biopsy forceps and snares, and into in-situ histopathology probes.

15

Fig. 4 schematically shows a light plane generating module 118 rigidly attached to a biopsy forceps 110 onto which pose pattern 112 has been created. Also seen in Fig. 4 is a polyp 114, the intersection 116 of the light plane with the polyp, and a double headed arrow 120 that represents the diameter of polyp 114.

20

Fig. 5 schematically shows a light plane generating module 118 rigidly attached to the over-tube 122 of a snare 124 onto which pose pattern 112 has been created. Also seen in Fig. 5 is a polyp 114, the intersection 116 of the light plane with the polyp, and a double headed arrow 120 that represents the diameter of polyp 114.

25

The light plane generating module can be attached to the tool externally as shown in Figs. 4 and 5, embedded in an additional lumen in the over-tube of Fig. 5, or in a completely integrated design, e.g. between the jaws of forceps.

30

- 13 -

Although embodiments of the invention have been described by way of illustration, it will be understood that the invention may be carried out with many variations, modifications, and adaptations, without exceeding the scope of the claims.

Claims

1. A method of determining the position and orientation of a manually-operated endoscopic tool relative to a camera focal point in an endoscopic image, the method comprising:
 - 5 a) identifying in the image features on the tip of the tool, wherein the features are at least one of salient features of the tip of the tool or features of an imprinted or engraved pose pattern created on the surface of the tip; and
 - 10 b) using a method of camera pose estimation to determine the position and orientation of the features in a 3D camera coordinate system, and therefore the position and orientation of the tool itself.
2. The method of claim 1, wherein the method of camera pose estimation is the Perspective-n-Point method for at least three feature points.
- 15 3. The method of claim 1, wherein the tool is a light plane generating module.
4. A method of using a manually-operated tool introduced to a site inside a lumen of a body through a working channel of an endoscopic device or
20 through a trocar to make accurate estimates of the dimensions of an object seen in images taken by an endoscopic camera, the method comprising:
 - a) placing the tool next to the objects;
 - 25 b) providing a processor device and software configured to analyze the camera images in order to:
 - 30 i) identify in the image features on the tip of the tool, wherein the features are at least one of salient features of the tip of the tool or features of an imprinted or engraved pose pattern created on the surface of the tip;

- 15 -

ii) use a method of camera pose estimation to determine the position and orientation of the features in a 3D camera coordinate system, and therefore the position and orientation of the tool itself; and

5 iii) use augmented reality techniques to superimpose on the camera image a virtual ruler at the tip of the tool in contact with the object to obtain accurate estimates of the dimensions of the object.

10 5. A method of using a manually-operated light plane generating module introduced to a site inside a lumen of a body through a working channel of an endoscopic device or through a trocar to make accurate measurements of the dimensions of an object seen in images taken by an endoscopic camera, the method comprising:

15 a) providing the light plane generating module with distinctive features, wherein the features are at least one of salient features of the light plane generating module or features of an imprinted or engraved pose pattern created on its surface;

20 b) introducing the light plane generating module until its tip is visible in the endoscopic image;

 c) aligning the light plane across the object to be measured;

 d) providing a processor device and software configured to analyze the camera images in order to:

 i) identify in the image the features;

25 ii) use a method of camera pose estimation to determine the position and orientation of the features in a 3D camera coordinate system, and therefore the position and orientation of the light plane generating module and the offset of the light plane from the camera focal point in the 3D camera coordinate system;

30

- 16 -

iii) determine the exact coordinates in the 3D camera coordinate system of pixels on the curves formed by intersection of the light plane with the object; and

iv) use the known 3D camera coordinates of pixels in the image to determine the actual dimensions of the object.

5

6. The method of claim 5, wherein augmented reality techniques are used to superimpose on the camera image a virtual tape measure with ticks along the intersection curves to assist in the visualization of the measurements.

10

7. The method of claim 5, wherein the processor device and software are configured to determine the offset of the light plane from the camera focal point and to provide audible or visual feedback for adequate positioning of a manually-operated endoscopic light plane measurement tool.

15

8. The method of claim 7, wherein feedback for adequate positioning of the light plane can be provided to the operator in at least one of the following ways:

20

a) the measurement process is disabled and an audible signal and or a visual message on the display is sent to the operator indicating that the measurement cannot be performed because the features are not visible or the offset is below a predetermined threshold;

25

b) textual or audible messages indicating the expected accuracy; and

c) color-coding the display to notify the user of the accuracy of the measurement.

9. A diagnostic or therapeutic endoscopic tool comprising an attached light plane generating module to provide the tool with integrated light plane measurement capabilities.

30

- 17 -

10. The diagnostic or therapeutic endoscopic tool of claim 9, wherein the light plane generating module is attached to the tool in one of the following ways: externally, embedded, and completely integrated.

5

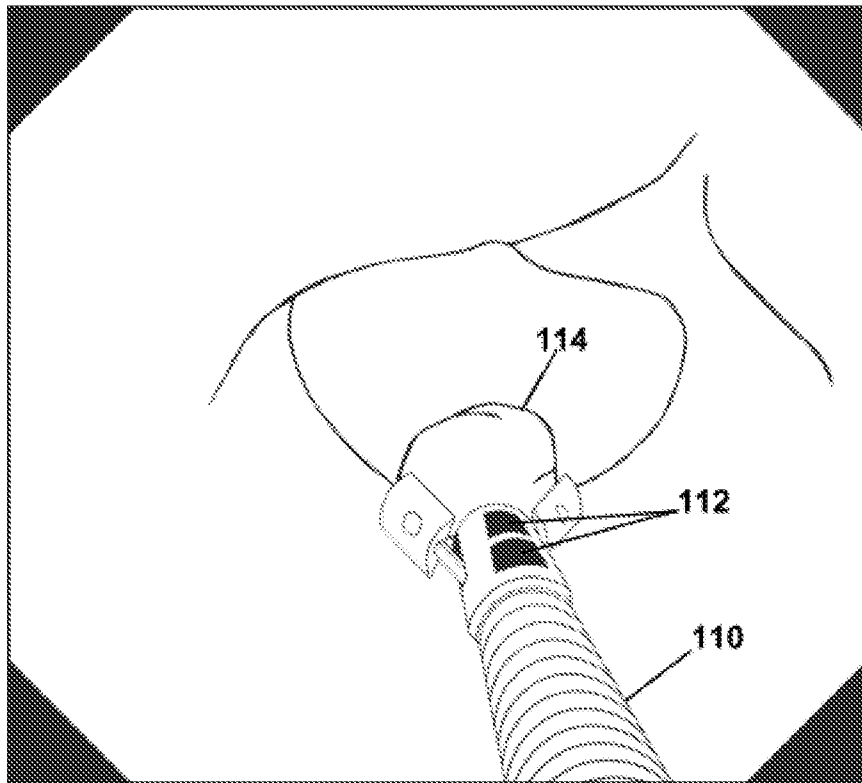

Fig. 1A

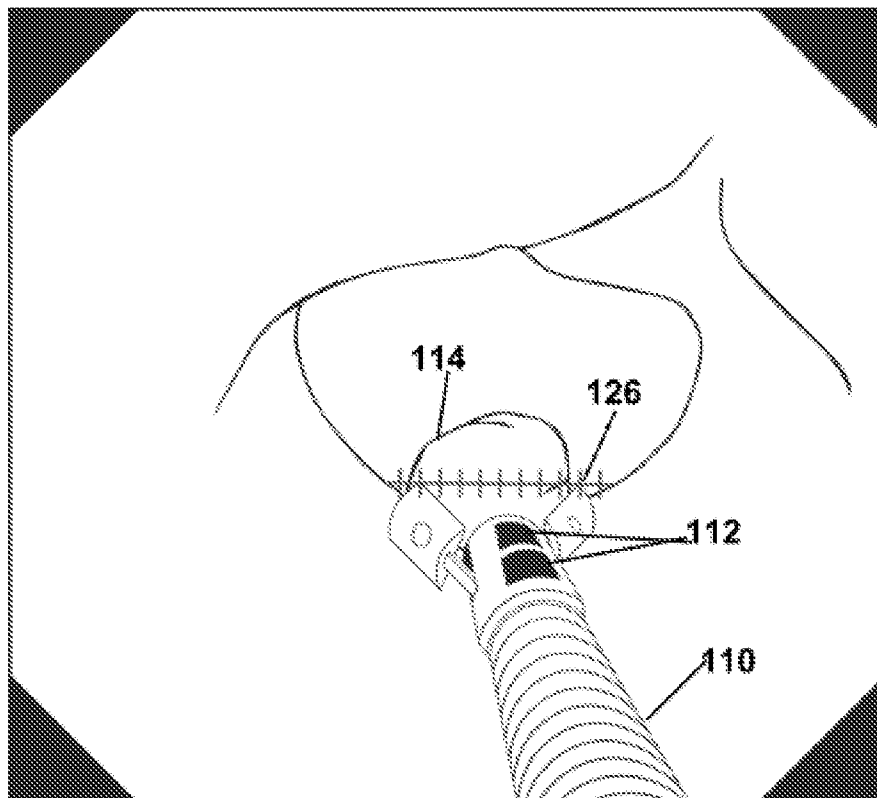

Fig. 1B

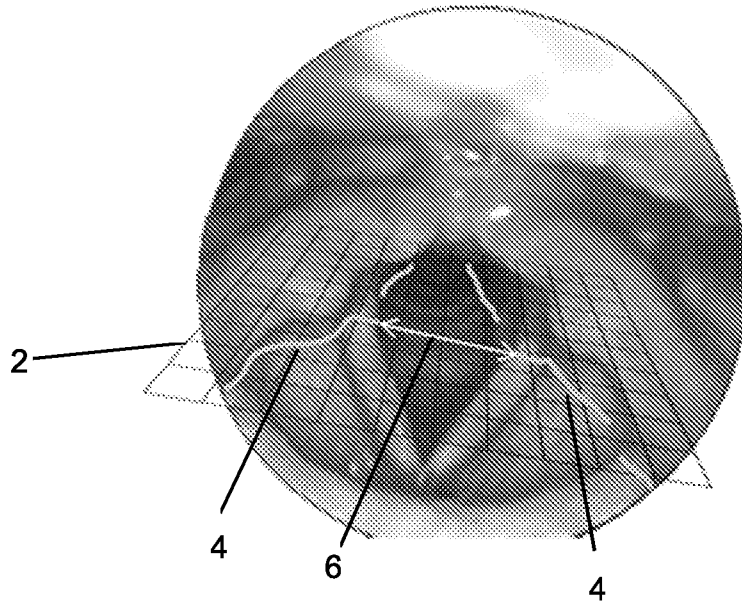

Fig 2
Prior Art

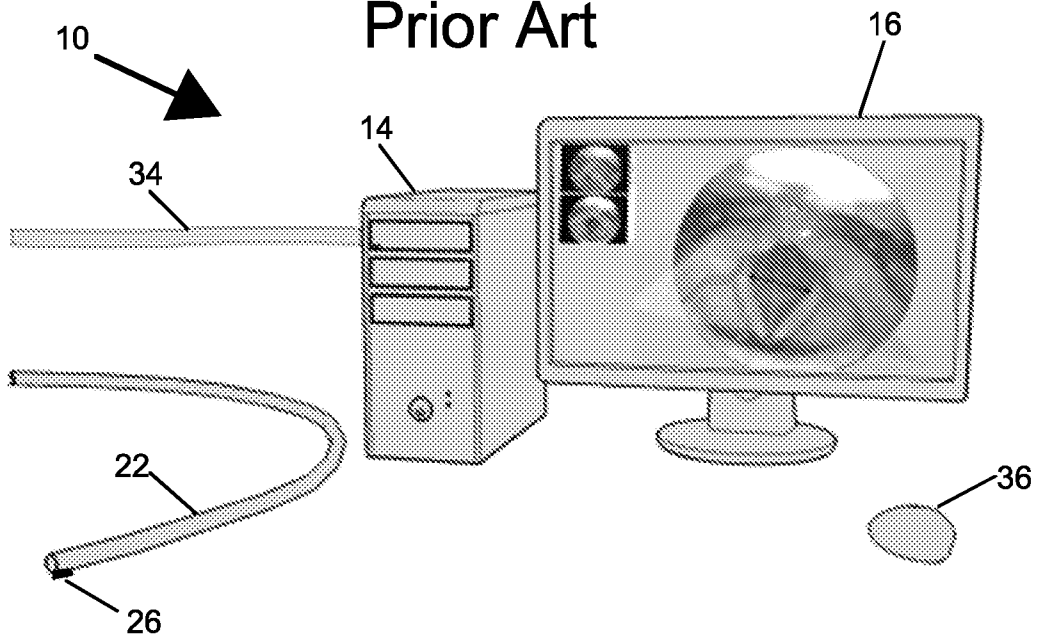

Fig. 3
Prior Art

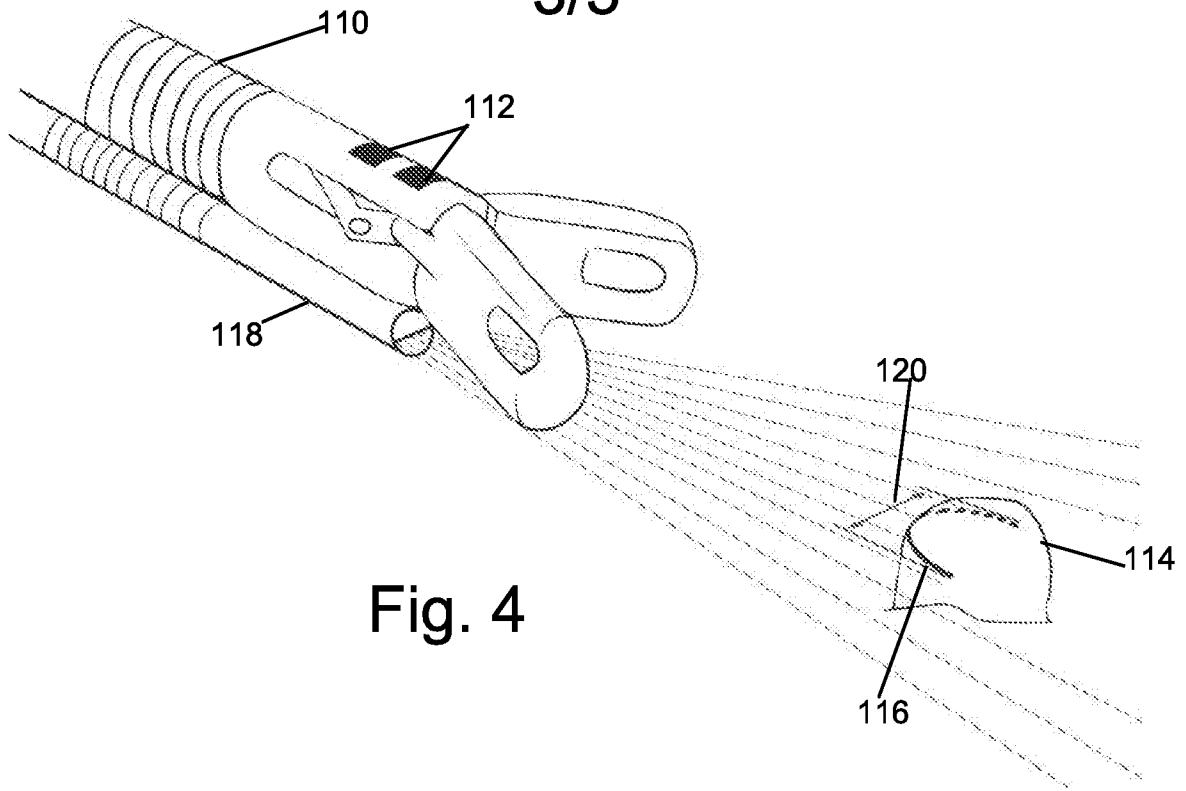

Fig. 4

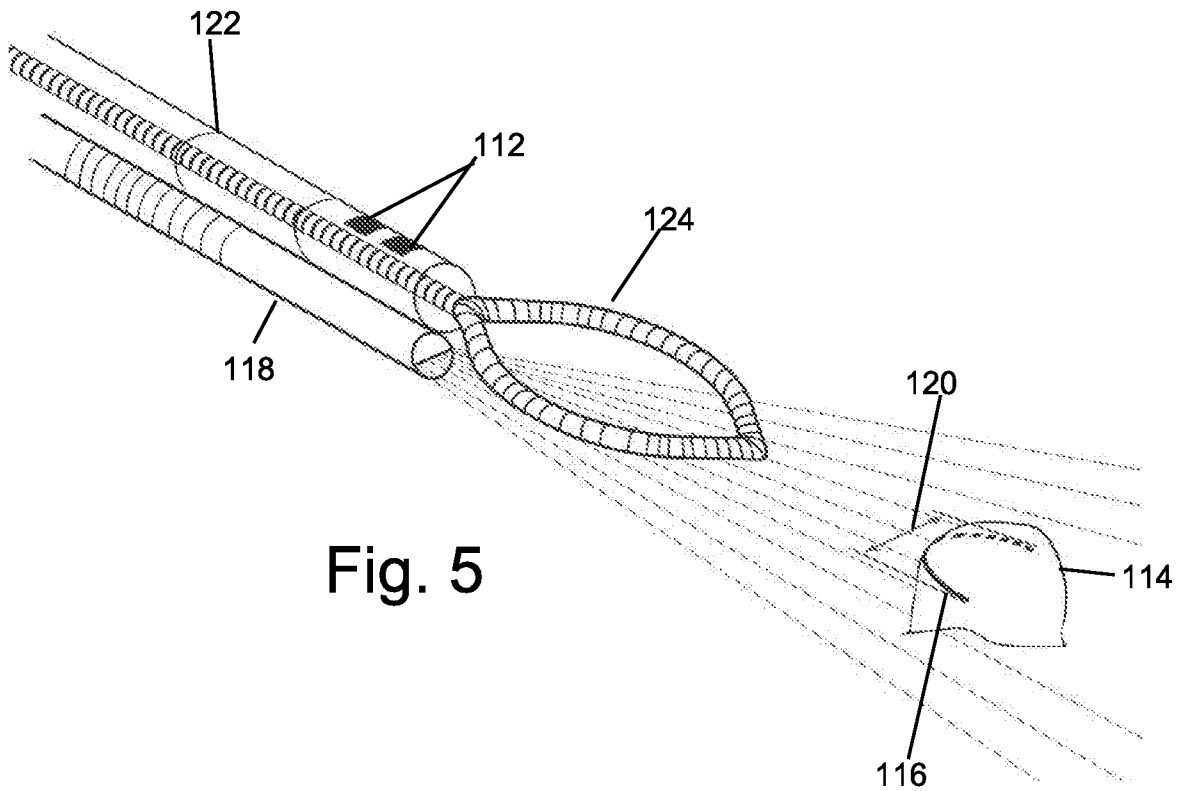

Fig. 5

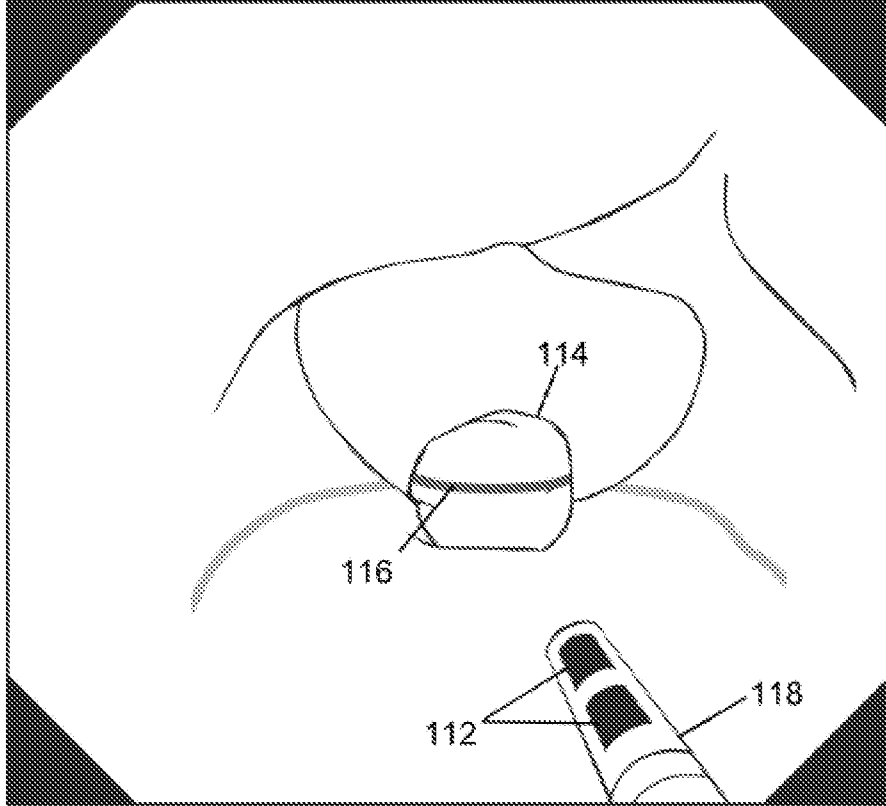

Fig. 6A

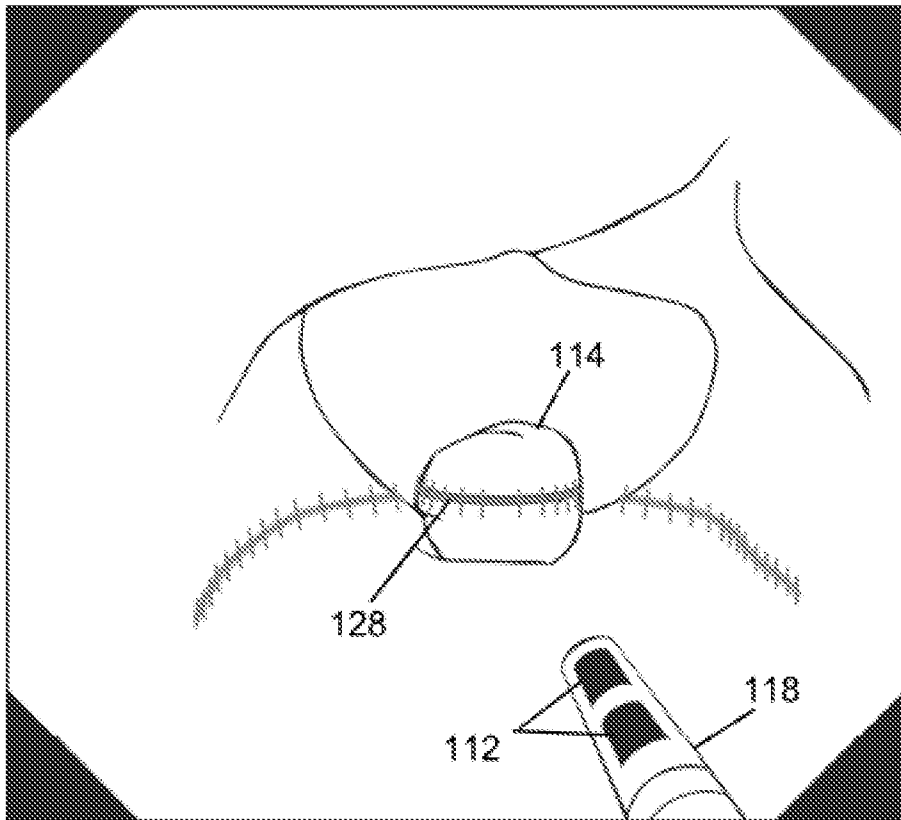

Fig. 6B

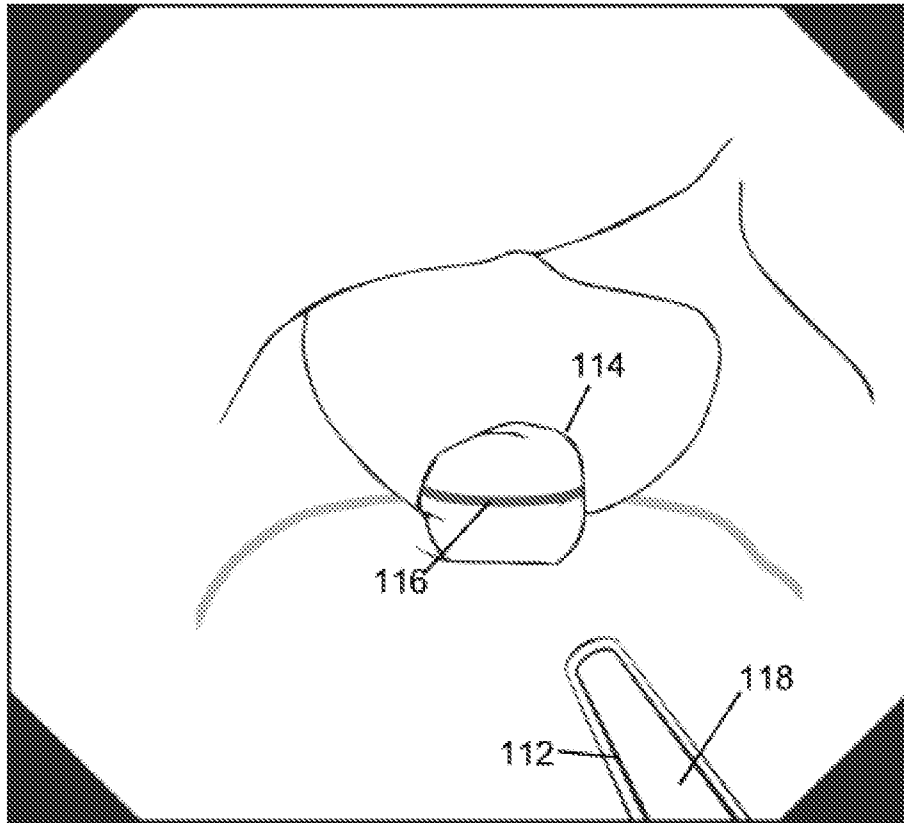

Fig. 6C

INTERNATIONAL SEARCH REPORT

International application No.

PCT/IL2018/050415

A. CLASSIFICATION OF SUBJECT MATTER

IPC (2018.01) A61B 34/20

According to International Patent Classification (IPC) or to both national classification and IPC

B. FIELDS SEARCHED

Minimum documentation searched (classification system followed by classification symbols)

IPC (2018.01) A61B 34/20

Documentation searched other than minimum documentation to the extent that such documents are included in the fields searched

Electronic data base consulted during the international search (name of data base and, where practicable, search terms used)

Databases consulted: Esp@cenet, Google Patents

Search terms used: "camera pose estimation" endoscope tip orientation contain markers or unique pattern;

C. DOCUMENTS CONSIDERED TO BE RELEVANT

Category*	Citation of document, with indication, where appropriate, of the relevant passages	Relevant to claim No.
X	WO 2016154557 A1 UNIV DE COIMBRA?[PT] 29 Sep 2016 (2016/09/29) ¶ 11, 29, 54, 70-71	1,2,4

Further documents are listed in the continuation of Box C.

See patent family annex.

* Special categories of cited documents:

“A” document defining the general state of the art which is not considered to be of particular relevance

“E” earlier application or patent but published on or after the international filing date

“L” document which may throw doubts on priority claim(s) or which is cited to establish the publication date of another citation or other special reason (as specified)

“O” document referring to an oral disclosure, use, exhibition or other means

“P” document published prior to the international filing date but later than the priority date claimed

“T” later document published after the international filing date or priority date and not in conflict with the application but cited to understand the principle or theory underlying the invention

“X” document of particular relevance; the claimed invention cannot be considered novel or cannot be considered to involve an inventive step when the document is taken alone

“Y” document of particular relevance; the claimed invention cannot be considered to involve an inventive step when the document is combined with one or more other such documents, such combination being obvious to a person skilled in the art

“&” document member of the same patent family

Date of the actual completion of the international search

19 Jul 2018

Date of mailing of the international search report

19 Jul 2018

Name and mailing address of the ISA:

Israel Patent Office

Technology Park, Bldg.5, Malcha, Jerusalem, 9695101, Israel

Facsimile No. 972-2-5651616

Authorized officer

MARCOWITZ Noam

Telephone No. 972-2-5651735

INTERNATIONAL SEARCH REPORT
Information on patent family members

International application No.
PCT/IL2018/050415

Patent document cited search report	Publication date	Patent family member(s)	Publication Date
WO 2016154557 A1	29 Sep 2016	WO 2016154557 A1	29 Sep 2016
		EP 3273854 A1	31 Jan 2018
		US 2018071032 A1	15 Mar 2018