

(19) World Intellectual Property Organization
International Bureau



(43) International Publication Date
1 December 2005 (01.12.2005)

PCT

(10) International Publication Number
WO 2005/114792 A1

(51) International Patent Classification⁷: H01Q 21/06,
1/38, 21/00

(21) International Application Number:
PCT/US2004/011934

(22) International Filing Date: 19 April 2004 (19.04.2004)

(25) Filing Language: English

(26) Publication Language: English

(71) Applicant (for all designated States except US): SOUTHERN METHODIST UNIVERSITY [US/US]; P.O. Box 750302, 6425 Boaz Lane, Dallas, TX 75205 (US).

(72) Inventor; and

(75) Inventor/Applicant (for US only): LEE, Choon, Sae [US/US]; 2936 Rosedale Avenue, Dallas, TX 75205 (US).

(74) Agents: CARR, Gregory, W. et al.; 670 Founders Square, 900 Jackson Street, Dallas, TX 75202 (US).

(81) Designated States (unless otherwise indicated, for every kind of national protection available): AE, AG, AL, AM,

AT, AU, AZ, BA, BB, BG, BR, BW, BY, BZ, CA, CH, CN, CO, CR, CU, CZ, DE, DK, DM, DZ, EC, EE, EG, ES, FI, GB, GD, GE, GH, GM, HR, HU, ID, IL, IN, IS, JP, KE, KG, KP, KR, KZ, LC, LK, LR, LS, LT, LU, LV, MA, MD, MG, MK, MN, MW, MX, MZ, NA, NI, NO, NZ, OM, PG, PH, PL, PT, RO, RU, SC, SD, SE, SG, SK, SL, SY, TJ, TM, TN, TR, TT, TZ, UA, UG, US, UZ, VC, VN, YU, ZA, ZM, ZW.

(84) Designated States (unless otherwise indicated, for every kind of regional protection available): ARIPO (BW, GH, GM, KE, LS, MW, MZ, SD, SL, SZ, TZ, UG, ZM, ZW), Eurasian (AM, AZ, BY, KG, KZ, MD, RU, TJ, TM), European (AT, BE, BG, CH, CY, CZ, DE, DK, EE, ES, FI, FR, GB, GR, HU, IE, IT, LU, MC, NL, PL, PT, RO, SE, SI, SK, TR), OAPI (BF, BJ, CF, CG, CI, CM, GA, GN, GQ, GW, ML, MR, NE, SN, TD, TG).

Declarations under Rule 4.17:

— as to applicant's entitlement to apply for and be granted a patent (Rule 4.17(ii)) for the following designations AE, AG, AL, AM, AT, AU, AZ, BA, BB, BG, BR, BW, BY, BZ, CA, CH, CN, CO, CR, CU, CZ, DE, DK, DM, DZ, EC, EE, EG, ES, FI, GB, GD, GE, GH, GM, HR, HU, ID, IL, IN, IS, JP, KE, KG, KP, KR, KZ, LC, LK, LR, LS, LT, LU, LV, MA,

[Continued on next page]

(54) Title: MICROSTRIP ARRAY ANTENNA

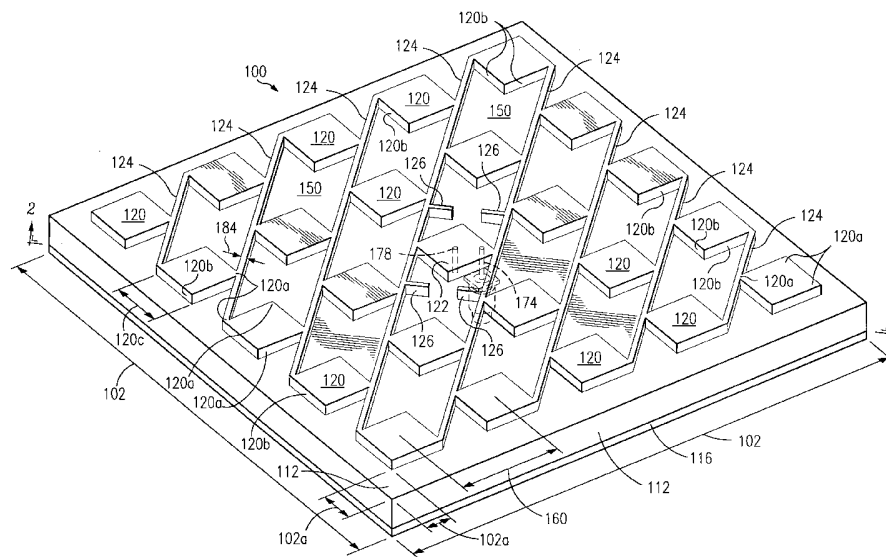

(57) Abstract: A microstrip antenna has a single dielectric layer with a conductive ground plane disposed on one side, and an array of spaced apart radiating patches disposed on the other side of the dielectric layer. The radiating patches are interconnected with a feed terminal via stripline elements. Responsive to electromagnetic energy, a high-order standing wave is induced in the antenna and a directed beam is transmitted from and/or received into the antenna. A dual-mode embodiment is configured such that standing wave nodes occur at the intersection of orthogonally situated striplines to minimize cross-polarization levels of the signals and the cross-talk between the two modes of operation.

WO 2005/114792 A1



MD, MG, MK, MN, MW, MX, MZ, NA, NI, NO, NZ, OM, PG, PH, PL, PT, RO, RU, SC, SD, SE, SG, SK, SL, SY, TJ, TM, TN, TR, TT, TZ, UA, UG, UZ, VC, VN, YU, ZA, ZM, ZW, ARIPO patent (BW, GH, GM, KE, LS, MW, MZ, SD, SL, SZ, TZ, UG, ZM, ZW), Eurasian patent (AM, AZ, BY, KG, KZ, MD, RU, TJ, TM), European patent (AT, BE, BG, CH, CY, CZ, DE, DK, EE, ES, FI, FR, GB, GR, HU, IE, IT, LU, MC, NL, PL, PT, RO, SE, SI, SK, TR), OAPI patent (BF, BJ, CF, CG, CI, CM, GA, GN, GQ, GW, ML, MR, NE, SN, TD, TG)

— of inventorship (Rule 4.17(iv)) for US only

Published:

— with international search report

For two-letter codes and other abbreviations, refer to the "Guidance Notes on Codes and Abbreviations" appearing at the beginning of each regular issue of the PCT Gazette.

MICROSTRIP ARRAY ANTENNATECHNICAL FIELD

5 A single dielectric layer multipatch, microstrip array antenna design contained in a leaky cavity, to distribute EM (electromagnetic) power between radiating patches and a feed source.

BACKGROUND

10 The invention relates generally to antennas and, more particularly, to microstrip array antennas.

The number of direct satellite broadcast services has substantially increased worldwide and, as it has, the worldwide demand for antennas having the capacity for receiving such broadcast services has also increased. This increased demand has typically been met by reflector, or "dish," antennas, which are well known in the art. Reflector antennas are commonly used in residential environments for receiving broadcast services, such as the transmission of television channel signals, from geostationary, or equatorial, satellites. Reflector antennas have several drawbacks, though. For example, they are bulky and relatively expensive for residential use. Furthermore, inherent in reflector antennas are feed spillover and aperture blockage by a feed assembly, which significantly reduces the aperture efficiency of a reflector antenna, typically resulting in an aperture efficiency of only about 55%.

25 An alternative antenna, such as a microstrip antenna, overcomes many of the disadvantages associated with reflector antennas. Microstrip antennas, for example, require less space, are simpler and less expensive to manufacture, and are more compatible than reflector antennas

with printed-circuit technology. Microstrip array antennas, *i.e.*, microstrip antennas having an array of microstrips, may be used with applications requiring high directivity. Microstrip array antennas, however, typically require a
5 complex microstrip feed network which contributes significant feed loss to the overall antenna loss. Furthermore, many microstrip array antennas are limited to single polarization and to transmitting or receiving only a linearly polarized beam. Such a drawback is particularly
10 significant in many parts of the world where broadcast services are provided using only circularly polarized beams. In such instances, the recipients of the services must resort to less efficient and more expensive, bulky reflector antennas, or microstrip array antennas which utilize a
15 polarizer. A polarizer, however, introduces additional power loss to the antenna and produces a relatively poor quality radiation pattern. Moreover, when dual polarization is needed, two antennas of single polarization are required.

What is needed, then, is a low-cost, simple to
20 manufacture and compact antenna having a high aperture efficiency, and which does not require a complex feed network, and which may be readily adapted for transmitting and/or receiving either linearly polarized or circularly polarized beams of single or dual polarization.

25

SUMMARY OF THE INVENTION

The present invention, accordingly, provides for a low-cost, compact antenna having a high aperture efficiency, and which does not require a complex feed network, which can be
30 readily adapted for transmitting and/or receiving either linearly polarized or circularly polarized beams, and which has a dual-polarization capability. To this end, a microstrip antenna of the present invention includes a

single dielectric layer with a conductive ground plane disposed on one side, and an array of spaced apart radiating patches disposed on the other side of the dielectric layer to form a leaky cavity. Responsive to electromagnetic energy, a directed beam is transmitted from and/or received into the antenna.

BRIEF DESCRIPTION OF THE DRAWINGS

For a more complete understanding of the present invention, and the advantages thereof, reference is now made to the following descriptions taken in conjunction with the accompanying drawings, in which:

FIGURE 1 is a perspective view of a planar array antenna;

FIGURE 2 is an elevation cross-sectional view of the antenna of FIGURE 1 taken along the line 2-2 of FIGURE 1;

FIGURE 3 is a perspective view of an alternate embodiment of the planar array antenna of FIGURE 1;

FIGURE 4 is a plan view of a planar array antenna;

FIGURE 5 is an elevation cross-sectional view of the antenna of FIGURE 4 taken along the line 5-5 of FIGURE 4;

FIGURE 6 is a plan view of a planar array antenna;

FIGURE 7 is an elevation cross-sectional view of the antenna of FIGURE 6 taken along the line 7-7 of FIGURE 6;

FIGURE 8 is a plan view of a planar array antenna;

FIGURE 9 is an elevation cross-sectional view of the antenna of FIGURE 8 taken along the line 9-9 of FIGURE 8;

FIGURE 10 is a plan view of a planar array antenna;

FIGURE 11 is an elevation cross-sectional view of the antenna of FIGURE 10 taken along the line 11-11 of FIGURE 10;

FIGURE 12 is an enlarged view of a portion of the antenna of FIGURE 11 circumscribed by the line 12 of FIGURE 10;

FIGURE 13 is a plan view of a planar array antenna;

5 FIGURE 14 is an elevation cross-sectional view of the antenna of FIGURE 13 taken along the line 14-14 of FIGURE 13;

10 FIGURE 15 is an enlarged view of a portion of the antenna of FIGURE 13 circumscribed by the line 15 of FIGURE 13;

FIGURE 16 is a plan view of a planar array antenna;

FIGURE 17 is an elevation cross-sectional view of the antenna of FIGURE 16 taken along the line 17-17 of FIGURE 16;

15 FIGURE 18 is a plan view of an alternate embodiment of the antenna of FIGURE 16;

FIGURE 19 is a plan view of a planar array antenna;

20 FIGURE 20 is an elevation cross-sectional view of the antenna of FIGURE 19 taken along the line 20-20 of FIGURE 19;

FIGURE 21 is a plan view of a planar array antenna;

FIGURE 22 is an elevation cross-sectional view of the antenna of FIGURE 21 taken along the line 22-22 of FIGURE 21;

25 FIGURE 23 is a plan view of a planar array antenna;

FIGURE 24 is an elevation cross-sectional view of the antenna of FIGURE 23 taken along the line 24-24 of FIGURE 23;

FIGURE 25 is a plan view of a planar array antenna;

30 FIGURE 26 is an elevation cross-sectional view of the antenna of FIGURE 25 taken along the line 26-26 of FIGURE 25;

FIGURE 27 is a plan view of a planar array antenna;

FIGURE 28 is an elevation cross-sectional view of the antenna of FIGURE 27 taken along the line 28-28 of FIGURE 27;

FIGURES 29A and 29B are a plan view of a planar array antenna;

FIGURE 30 is an elevation cross-sectional view of the antenna of FIGS. 29A and 29B taken along the line 30-30 of FIGS. 29A and 29B;

FIGURE 31 is a bottom view of a microstrip of the antenna of FIGURE 30;

FIGURE 32 is a plan view of a planar array antenna;

FIGURE 33 is an elevation cross-sectional view of the antenna of FIGURE 32 taken along the line 33-33 of FIGURE 32;

FIGURE 34 is a plan view of a planar microstrip directional coupler embodying features of the present invention for coupling two EM energy sources to two EM energy destinations; and

FIGURE 35 is an elevation cross-sectional view of the coupler of FIGURE 34 taken along the line 35-35 of FIGURE 34.

DETAILED DESCRIPTION OF THE PREFERRED EMBODIMENT

In the following discussion of the drawings, certain depicted elements are, for the sake of clarity, not necessarily shown to scale, and like or similar elements are designated by the same reference numeral through the several views.

Two types of antennas are described hereinafter. One is a linearly polarized antenna that has one feed for a single-mode operation. In this embodiment, crisscrossing or intersecting stripline conductors are not required and the structure is simpler. The other is a dual-mode antenna with

two input feeds that are operational independently each other and has crisscrossing or intersecting stripline conductors connecting the patches to the feed connectors.

In the dual mode configuration, the antenna acts as two
5 antennas superimposed. Such an antenna may use two feed terminals with the stripline conductors of one terminal being orthogonal to the stripline conductors of the other terminal. Each of the patches in the antenna are connected at one corner, or other point at which two orthogonal modes
10 can be excited, of a patch to a stripline conductor of a first orientation and at an adjacent corner or point to a stripline conductor of a second directional (orthogonal) orientation. In this embodiment, the placement of the patches and the stripline conductors are such that nodes of
15 the standing wave are coincident with the stripline intersections to reduce the cross-polarization level and cross talking. The occurrence of the standing wave nodes at each of the stripline conductors produces a predetermined or predefined desirable field distribution.

20 For a maximum directivity of the antenna, the design would be such to provide uniform distribution of power among the radiating patches. When configured for a uniform field distribution, all the patches may be the same physical size and all the interconnecting striplines may retain the same
25 dimensions, thus greatly simplifying the design process and manufacturing tolerances. This is in contrast to prior art designs requiring a number of different parameters for the striplines interconnecting the radiating patch elements to obtain a relatively uniform field distribution among the
30 radiating patches for maximum directivity.

On the other hand, in some applications, a tapered distribution across the radiating patches is preferred to

reduce sidelobes despite the fact that the directivity may have to be reduced from an optimum value.

A dual-mode antenna, as presented herein, can produce two orthogonal linearly polarized radiations or, with some modifications in the feed area, two orthogonal circularly polarized (i.e., right-handed and left-handed) radiations. It will be realized that the dual-mode antenna can be used for a single-mode operation simply by not using the other port. It should also be realized that for optimum results, in a dual mode antenna, the radiating patches should have two-fold symmetry.

The stripline conductors, alternatively just striplines in the art, form part of the surface of the leaky cavity and thus influence the resonant frequency of the cavity while facilitating the power flow among the radiating patch elements. The striplines act to guide the power flow properly so that the leaked power is channeled in the desired direction, namely radiation, while minimizing other factors to maximize the antenna efficiency. In prior art antennas, the striplines serve as a conductive path by which the traveling wave is transferred from the feed to the radiating patches. In the present context, the stripline serves as a channel to bridge the patches and the feed such that energy flows back and forth, thus resulting in some form of standing wave on the channel bridge. As used hereinafter in this document, the word stripline is intended to apply to any conductive material, other than the radiating patches, that further encloses the cavity and exists on the surface of the dielectric opposite the ground plane, that is used to guide the power flow in the form of a traveling wave, standing wave or combination of the two.

In view of the multiple embodiments possible in such a single-dielectric layer antenna using both standing and

traveling waves, a plurality of configurations from simple to complex are illustrated and discussed in the following paragraphs.

It is noted that, unless specified otherwise, λ_0 is understood to be the wavelength of a beam of EM energy in free space (*i.e.*, $\lambda_0=c/f$, where c is the speed of light in free space, and f is the frequency of the beam), and that λ_ϵ is understood to be the wavelength of a beam of EM energy in a dielectric medium (*i.e.*, $\lambda_\epsilon=v/f$, where v is the speed of light in the dielectric medium). It is further understood that, as used herein, elements referred to as "strips," "patches," "striplines," "stubs," and "transmission lines" constitute conductive microstrips, which preferably have a thickness of approximately 1 mil (0.001 inch). Ground planes and edge conductors, preferably, also have a thickness of approximately 1 mil, but may be thicker (*e.g.*, 0.125 inches), if desired, for providing structural support to a respective antenna. It is understood that thickness is generally measured in a direction perpendicular to the surface of dielectric to which the microstrips, ground planes, or edge conductors are respectively bonded

It is further noted that, unless specified otherwise, dielectric material used in accordance with the present invention (in other than cables) is preferably fabricated from a mechanically stable material having a relatively low dielectric constant. A dielectric layer may be suitably multilayered to provide a desired dielectric constant. The single dielectric layer, whether or not composite, preferably, has a thickness of between $0.003 \lambda_\epsilon$ and $0.050 \lambda_\epsilon$, although it may have a greater thickness for greater bandwidths.

It is further noted that reference to a high-order standing wave, as used herein, comprises one of the high-

order standing waves defining modes other than a fundamental mode.

It is still further noted that, as used herein (unless indicated otherwise), ground planes, edge conductors, microstrips (e.g., strips and patches), and the like, preferably comprise conductive materials such as copper, aluminum, silver, and/or gold. Reference made herein to the bonding of such conductive materials to a dielectric material may, preferably, be achieved using conventional printed-circuit, metallizing, decal transfer, monolithic microwave integrated circuit (MMIC) techniques, chemical etching techniques, or any other suitable technique. For example, in accordance with a chemical etching technique, a dielectric layer may be clad to one of the aforementioned conductive materials. The conductive material may then be selectively etched away from the dielectric layer using conventional chemical etching techniques, to thereby define any of the microstrip patterns described herein. Where applicable, a second dielectric layer may be bonded to the surface of the aforementioned dielectric having the conductive material, using any suitable technique, such as by creating a bond with very thin (e.g., 1.5 mil) thermal bonding film.

It is still further noted that reference is made in the following description of the present invention to the use of calculations and analyses, such as the cavity model and the moment method, discussed, for example, by C. S. Lee, V. Nalbandian, and F. Schwering in an article entitled "Planar dual-band microstrip antenna", published in the IEEE Transactions on Antennas and Propagation, Vol. 43, pp. 892-895, August 1995, and by T. H. Hsieh, "Double-layer Microstrip Antenna", published as a Ph.D. dissertation in the Electrical Engineering Department at Southern Methodist

University in 1998. Both of these articles are hereby incorporated in their entirety by reference, and will together be referred to hereinafter as "Lee and Hsieh".

5 **MEDIUM-GAIN ANTENNA APPLICATIONS (FOR BASE-STATION ANTENNAS)**

FIGURES 1-3

Referring to FIGURES 1 and 2, the reference numeral 100 designates, in general, a planar microstrip array antenna embodying features of the present invention for transmitting
10 and receiving beams. The antenna 100 preferably includes a generally square, dielectric layer 112. The width 102 and length 102 of the layer 112 are determined by the number and spacing of patches used, discussed below, and, preferably, extends a width and length 102a of at least $0.50 \lambda_e$ beyond
15 the outer edges of patches 120.

As shown most clearly in FIGURE 2, the dielectric layer 112 defines a bottom side 112a to which a conductive ground plane 116 is bonded, and a top side 112b to which an array of conductive radiating patches 120 and a center radiating
20 patch 122 are bonded for forming a radiating cavity within the dielectric layer 112, between the patches 120, 122, the striplines 124 and the ground plane 116. Referring back to FIGURE 1, the patches 120 and 122 are generally square in shape, each having four corners 120a and four radiating
25 edges 120b, each edge preferably having a length 120c of about $0.50 \lambda_e$. The patches 120 and 122 are electrically interconnected via either one corner 120a or two diametrically opposed corners 120a to an array of substantially parallel conductive striplines 124. Four
30 tuning stubs 126 extend perpendicularly from two striplines 124. The patches 120 and 122 are preferably spaced apart by a center-to-center distance 160 of approximately $1.0 \lambda_e$. The patches 120 and 122 are preferably arranged in a square

array on the top surface 112b preferably having an equal number of rows and columns of patches 120 and 122, exemplified in FIGURE 1 as a square array having five rows and columns of patches 120 and 122 for a total of twenty-five patches 120 and 122 that constitute the antenna 100. The width 184 of each stripline 124 and the width and length of each stub 126 is preferably determined assuming a characteristic impedance of about 50 to 200 ohms. A shortening pin 178 is preferably disposed in the antenna 100 electrically connecting the ground plane 116 to the center patch 122 to suppress unwanted mode excitations. Additional shortening pins (not shown) may also be disposed in the antenna 100 connecting the ground plane 116 to patches 120 to further suppress unwanted mode excitations. Alternatively, in some instances, it may be preferable to omit one or all shortening pins 28 from the antenna 100.

For optimal performance at a particular frequency, the dimensions of the patches 120 and 122, the striplines 124, the stubs 126, the apertures 150, and the center-to-center spacing 160, are individually calculated so that a high-order standing wave is generated in the antenna cavity formed within the dielectric 112, and so that fields radiated from the radiating edges 120b interfere constructively with one another to give desired antenna characteristics, such as a high directivity. The number of patches 120 and 122 determines not only the overall size, but also the directivity, of the antenna 100. The sidelobe levels of the antenna 100 are determined by the field distribution among the radiating elements 120. Therefore, antenna characteristics, such as directivity and sidelobe levels, are controlled by the size and the position of each of the patches 120 and 122 and the feeding scheme. To achieve high directivity, the field distribution among the

radiating elements is assumed to be as uniform as possible. The foregoing calculations and analysis utilize techniques, such as the cavity-model method and the moment method, discussed, for example, by Lee and Hsieh and will, therefore, not be discussed in further detail herein.

A conventional SMA (SubMiniature type A) probe 170 is provided for transmitting or receiving beams. Each SMA probe 170 includes, for delivering EM energy to and/or from the antenna 100, an outer conductor 172 which is electrically connected to the ground plane 116, and an inner (or feed) conductor 174 which is electrically connected to the center patch 122. The probe 170 is positioned along a diagonal of the patch 122 proximate to the stripline 124 to optimize the impedance matching of the antenna 100. While it is preferable that the probes 170 be SMA probes, any suitable coaxial probe and/or connection arrangement may be used to implement the foregoing connections. For example, a conductive adhesive (not shown) may be used to bond and maintain contact between the inner conductor 174 and the center patch 122, and an appropriate seal (not shown) may be provided where the SMA probe 170 passes through the ground plane 116 to hermetically seal the connection. It is understood that the other end of the SMA probe 170, not connected to the antenna 100, is connectable via a cable (not shown) to a signal generator or to a receiver, such as a satellite signal decoder used with television signals.

In operation, the antenna 100 may be used for receiving or transmitting linearly polarized (LP) EM beams. To exemplify how the antenna 100 may be used to receive a beam, the antenna 100 may be positioned in a residential home and directed for receiving from a geostationary, or equatorial, satellite a beam carrying a television signal within a predetermined frequency band or channel. The antenna 100 is

so directed by orienting the top surface 112b toward the source of the beam so that it is generally perpendicular to the direction of the beam. Assuming that the elements of the antenna 100 are correctly sized for receiving the beam, then the beam will pass through the apertures 150 and induce a standing wave, which will resonate within the dielectric layer 112. A standing wave induced in the resonant cavity defined by the dielectric layer 112 is communicated through the SMA probe 170 to a receiver, such as a decoder (not shown). It is well known that antennas transmit and receive signals reciprocally. It can be appreciated, therefore, that operation of the antenna 100 for transmitting signals is reciprocally identical to that of the antenna for receiving signals. The transmission of signals by the antenna 100 will, therefore, not be further described herein.

It is understood that the present invention can take many forms and embodiments. The embodiments described with respect to FIGURES 1 and 2 are intended to illustrate rather than to limit the invention. Accordingly, several variations may be made in the foregoing without departing from the spirit or the scope of the invention. For example, additional patches 120 may be provided for narrowing a beam, or fewer patches 120 may be utilized to reduce the physical space required for the antenna 100 of the present invention. The embodiments of FIGURES 1 and 2 may be configured in a triangular structure for use in a telecom cell. The stubs 126 may be reconfigured to form alternate embodiments, one of which is exemplified and discussed in greater detail below with respect to FIGURE 3.

FIGURE 3 depicts the details of a single mode antenna 300 according to an alternate embodiment of the present invention. Since the antenna 300 contains many elements

that are identical to those of the antenna 100, these elements are referred to by the same reference numerals and will not be described in any further detail. According to the embodiment of FIG. 3, and in contrast to the embodiment of FIGURE 1, the four stubs 126 are replaced by two stubs 326 which extend outwardly along a line extending diagonally across the center patch 122. Operation of the antenna 300 depicted in FIG. 3 is otherwise substantially similar to the operation of the antenna 100 depicted in FIG. 1.

10 FIGURES 4-7

Referring to FIGURES 4 and 5, the reference numeral 400 designates, in general, a planar microstrip array antenna embodying features of the present invention for dual-mode operation, such as transmitting and/or receiving EM beams. The antenna 400 preferably includes a generally square, dielectric layer 412. The width 402 and length 402 of the layer 412 is determined by the number of patches used, discussed below, and, preferably, extends a width and length 402a of at least $0.50 \lambda_e$ beyond the outer edges of patches 420.

As shown most clearly in FIGURE 5, the dielectric layer 412 defines a bottom side 412a to which a conductive ground plane 416 is bonded, and a top side 412b to which an array of conductive radiating patches 420 and a center radiating patch 422 are bonded for forming a resonant cavity within the dielectric layer 412 between the patches 420 and 422, striplines 424 and 424, and the ground plane 416. Referring back to FIGURE 4, the patches 420 and 422 are generally square in shape, each having four corners 420a and four radiating edges 420b, each having a length 420c of about $0.50 \lambda_e$. As viewed in FIG. 4, the patches 420 and 422 are electrically interconnected via corners 420a to an array of substantially parallel horizontal conductive striplines 424

and an array of substantially parallel vertical conductive striplines 426 bonded to the dielectric layer 412. Four tuning stubs 428 extend diagonally outwardly from the corners 420a of the center patch 422 and from the horizontal striplines 424 and vertical striplines 426, and are also bonded to the dielectric layer 412. The patches 420 and 422 are preferably spaced apart by a center-to-center distance 460 of slightly less than $1.0 \lambda_e$. The patches 420 and 422 are preferably arranged in a square array on the top surface 412b having an equal odd number of rows and columns (viewed at 45° angles to horizontal in FIGURE 4) of patches 420 and 422, exemplified in FIG. 4 as a square array having five rows and five columns of patches 420 and 422 for a total of twenty-five patches 420 and 422 that constitute the antenna 400. The width 484 (FIG. 4) of each stripline 424 and 426 and the width of each stub 428 are preferably determined assuming a characteristic impedance of about 50 to 200 ohms. A shortening pin 478 is preferably disposed in the antenna 400 electrically connecting the ground plane 416 to the center patch 422 to suppress unwanted mode excitations. Additional shortening pins (not shown) may also be disposed in the antenna 400 connecting the ground plane 416 to patches 420 to further suppress unwanted mode excitations. Alternatively, in some instances, it may be preferable to omit one or all shortening pins 478 from the antenna 400.

For optimal performance at a particular frequency, the dimensions of the patches 420 and 422, the striplines 424 and 426, the stubs 428, the apertures 450, and the center-to-center spacing 460 are individually calculated so that a high-order standing wave is generated in the antenna cavity formed within the dielectric 412, and so that fields radiated from the radiating edges 420b interfere constructively with one another.

The number of patches 420 and 422 determines not only the overall size, but also the directivity, of the antenna 400. The sidelobe levels of the antenna 400 are determined by the field distribution among the radiating elements 420.

5 Therefore, antenna characteristics, such as directivity and sidelobe levels, are controlled by the size and the position of each of the patches 420 and 422 and the feeding scheme. To achieve high directivity, the field distribution among the radiating elements 420 is assumed to be as uniform as possible.

10 There are electric field null points in the dielectric layer 412 within the patches 420 and 422 and the connecting striplines 424 and 426. The foregoing calculations and analysis utilize techniques, such as the cavity model, discussed, for example, by Lee and Hsieh, and

15 the moment method, discussed, for example, in the software Ensemble™ available from Ansoft Corp located in Pittsburgh, Pennsylvania, and will, therefore, not be discussed in further detail herein.

Preferably, two conventional SMA probes 470 are

20 provided for dual mode operation, such as transmitting or receiving beams. Each SMA probe 470 includes, for delivering EM energy to and/or from the antenna 400, an outer conductor 472 which is electrically connected to the ground plane 416, and an inner (or feed) conductor 474 which

25 is electrically connected to the center patch 422. The probe 470 is positioned along a diagonal of the patch 422 proximate to the striplines 424 and 426 to optimize the impedance matching of the antenna 400, and reduce cross-talking and cross-polarization. While it is preferable that

30 the probes 470 be SMA probes, any suitable coaxial probe and/or connection arrangement may be used to implement the foregoing connections. For example, a conductive adhesive (not shown) may be used to bond and maintain contact between

the inner conductor 474 and the center patch 422, and an appropriate seal (not shown) may be provided where the SMA probe 470 passes through the ground plane 416 to hermetically seal the connection. It is understood that the other end of the SMA probe 470, not connected to the antenna 400, is connectable via a cable (not shown) to a signal generator or to a receiver, such as a satellite signal decoder used with television signals.

In operation, the antenna 400 may be used for receiving or transmitting linearly polarized (LP) EM beams. To exemplify how the antenna 400 may be used to receive a beam, the antenna 400 may be positioned in a residential home and directed for receiving from a geostationary, or equatorial, satellite a beam carrying a television signal within a predetermined frequency band or channel. The antenna 400 is so directed by orienting the top surface 412b toward the source of the beam so that it is generally perpendicular to the direction of the beam. Assuming that the elements of the antenna 400 are correctly sized for receiving the beam, then the beam will pass through the apertures 450 and induce a standing wave, which will resonate within the dielectric layer 412. A standing wave induced in the resonant cavity defined by the dielectric layer 412 is communicated through the SMA probe 470 to a receiver such as a decoder (not shown).

In the antenna 400, the vertical modal excitation becomes orthogonal to that of the horizontal mode so that the cross talk between the two input signals will be minimized. In other words, two orthogonal vertical and horizontal modes can be excited independently.

It is well known that antennas transmit and receive signals reciprocally. It can be appreciated, therefore, that operation of the antenna 400 for transmitting signals

is reciprocally identical to that of the antenna for receiving signals. The transmission of signals by the antenna 400 will, therefore, not be further described herein.

5 It is understood that the present invention can take many forms and embodiments. The embodiments described with respect to FIGURES 4 and 5 are intended to illustrate rather than to limit the invention. Accordingly, several variations may be made in the foregoing without departing
10 from the spirit or the scope of the invention. For example, additional patches 420 may be provided for narrowing a beam, or fewer patches 420 may be utilized to reduce the physical space required for the antenna 400 of the present invention. An embodiment utilizing fewer patches is exemplified in
15 FIGURES 6 and 7 by an antenna 600. In another example, one of the two SMA probes 470 may be removed (or not attached) for single-mode operation in transmitting and receiving EM beams. The antenna 400 may also be used for receiving and/or transmitting circularly polarized (CP) EM beams. In
20 some instances, it may be preferable to omit the shortening pin 478 from the antenna 400.

FIGURES 8-9

Referring to FIGURES 8 and 9, the reference numeral 800 designates, in general, a planar microstrip array antenna
25 embodying features of the present invention for dual-mode operation, such as transmitting and/or receiving EM beams. The antenna 800 preferably includes a generally square, dielectric layer 812. The width 802 and length 802 of the layer 812 is determined by the number of patches 820 used,
30 discussed below, and, preferably, extends a width and length 802a of at least $0.50 \lambda_e$ beyond the outer edges of the patches 820.

As shown most clearly in FIGURE 9, the dielectric layer 812 defines a bottom side 812a to which a conductive ground plane 816 is bonded, and a top side 812b to which an array of conductive radiating patches 820 and four center radiating patches 822 are bonded for forming a resonant cavity within the dielectric layer 812 between the patches 820 and 822, the striplines 824, 826, and the ground plane 816. Referring back to FIGURE 8, the patches 820 and 822 are generally square in shape, each having four corners 820a and four radiating edges 820b, each having a length 820c of about $0.50 \lambda_c$. As viewed in FIG. 8, the patches 820 and 822 are electrically interconnected via corners 820a to an array of substantially parallel horizontal conductive striplines 824, and an array of substantially parallel vertical conductive striplines 826 bonded to the dielectric layer 812. A tuning stub 828 extends diagonally outwardly from a corner 820a of each center patch 822 and toward the center of the antenna 800. The stubs 828 are also bonded to the dielectric layer 812. The patches 820 and 822 are preferably spaced apart by a center-to-center distance 860 of slightly less than $1.0 \lambda_c$. The patches 820 and 822 are preferably arranged in a square array on the top surface 812b having an equal even number of rows and columns (viewed at 45° angles to horizontal in FIG. 8) of patches 820 and 822, exemplified in FIG. 8 as a square array having four rows and four columns of patches 820 and 822 for a total of sixteen patches 820 and 822 that constitute the antenna 800. The width 884 (FIG. 8) of each stripline 824 and 826 and the width and length of each stub 828 is preferably determined assuming a characteristic impedance of about 50 to 200 ohms. A shortening pin 878 is preferably disposed in the antenna 800 electrically connecting the ground plane 816 to each center patch 822 to suppress unwanted mode excitations.

Additional shortening pins (not shown) may also be disposed in the antenna 800 connecting the ground plane 816 to patches 820 to further suppress unwanted mode excitations. Alternatively, in some instances, it may be preferable to
5 omit one or all shortening pins 878 from the antenna 800.

For optimal performance at a particular frequency, the dimensions of the patches 820 and 822, the striplines 824 and 826, the stubs 828, the apertures 850, and the center-to-center spacing 860 are individually calculated so that a
10 high-order standing wave is generated in the antenna cavity formed within the dielectric 812, and so that fields radiated from the radiating edges 820b interfere constructively with one another.

The number of patches 820 and 822 determines not only
15 the overall size, but also the directivity, of the antenna 800. The sidelobe levels of the antenna 800 are determined by the field distribution among the radiating elements 820 and 822. Therefore, antenna characteristics, such as directivity and sidelobe levels, are controlled by the size
20 and the position of each of the patches 820 and 822 and the feeding scheme. To achieve high directivity, the field distribution among the radiating elements 820 and 822 is assumed to be as uniform as possible. The foregoing calculations and analysis utilize techniques, such as the
25 cavity model, discussed, for example, by Lee and Hsieh, and the moment method, discussed, for example, in the software Ensemble™ available from Anasoft Corp., and will, therefore, not be discussed in further detail herein.

Preferably, two conventional SMA probes 870 are
30 provided for dual mode operation, such as transmitting or receiving beams. Each SMA probe 870 includes, for delivering EM energy to and/or from the antenna 800, an outer conductor 872 which is electrically connected to the

ground plane 816, and an inner (or feed) conductor 874 which is electrically connected to a center patch 822. The two SMA probes 870 are thusly connected to two selected adjacent center patches 822. The probes 870 are positioned along a diagonal of the two selected respective center patches 822 proximate to the striplines 824 and 826 to optimize the impedance matching of the antenna 800, and reduce cross-talking and cross-polarization. While it is preferable that the probes 870 be SMA probes, any suitable coaxial probe and/or connection arrangement may be used to implement the foregoing connections. For example, a conductive adhesive (not shown) may be used to bond and maintain contact between the inner conductor 874 and the center patch 822, and an appropriate seal (not shown) may be provided where the SMA probe 870 passes through the ground plane 816 to hermetically seal the connection. It is understood that the other end of the SMA probe 870, not connected to the antenna 800, is connectable via a cable (not shown) to a signal generator or to a receiver such as a satellite signal decoder used with television signals.

In operation, the antenna 800 may be used for receiving or transmitting linearly polarized (LP) EM beams. To exemplify how the antenna 800 may be used to receive a beam, the antenna 800 may be positioned in a residential home and directed for receiving from a geostationary, or equatorial, satellite a beam carrying a television signal within a predetermined frequency band or channel. The antenna 800 is so directed by orienting the top surface 812b toward the source of the beam so that it is generally perpendicular to the direction of the beam. Assuming that the elements of the antenna 800 are correctly sized for receiving the beam, then the beam will pass through the apertures 850, and induce a standing wave which will resonate within the

dielectric layer 812. A standing wave induced in the resonant cavity defined within the dielectric layer 812 is communicated through the SMA probes 870 to a receiver, such as a decoder (not shown).

5 In the antenna 800, the vertical modal excitation becomes orthogonal to that of the horizontal mode so that the cross talk between the two input signals may be minimized. In other words, two orthogonal vertical and horizontal modes can be excited independently.

10 It is well known that antennas transmit and receive signals reciprocally. It can be appreciated, therefore, that operation of the antenna 800 for transmitting signals is reciprocally identical to that of the antenna for receiving signals. The transmission of signals by the
15 antenna 800 will, therefore, not be further described herein.

It is understood that the present invention can take many forms and embodiments. The embodiments described with respect to FIGURES 8 and 9 are intended to illustrate rather
20 than to limit the invention. Accordingly, several variations may be made in the foregoing without departing from the spirit or the scope of the invention. For example, additional patches 820 may be provided for narrowing a beam, or fewer patches 820 may be utilized to reduce the physical
25 space required for the antenna 800 of the present invention. In another example, one of the two SMA probes 870 may be removed (or not attached) for single-mode operation in transmitting or receiving EM beams. The antenna 800 may also be used for receiving and/or transmitting circularly
30 polarized (CP) EM beams.

FIGURES 10-12

Referring to FIGURES 10-12, the reference numeral 1000 designates, in general, a planar microstrip array antenna

embodying features of the present invention for dual-mode operation, such as transmitting and/or receiving EM beams. The antenna 1000 preferably includes generally square, first and second dielectric layers 1012 and 1014. The width 1002 and length 1002 of the layers 1012 and 1014 are determined
5 by the number of patches 1020 and 1022 used, discussed below, and, preferably, extends a width and length 1002a of at least $0.50 \lambda_c$ beyond the outer edges of the patches 1020.

As shown most clearly in FIGURE 11, the dielectric
10 layer 1012 defines a bottom side 1012a to which a conductive ground plane 1016 is bonded, and a top side 1012b to which an array of conductive radiating patches 1020 and four center radiating patches 1022 are bonded for forming a resonant cavity within the dielectric layer 1012 between the
15 patches 1020 and 1022, the striplines 1024 and 1026, and the ground plane 1016. The second dielectric 1014 is bonded to the top side 1012b of the dielectric 1012, such that the patches 1020 and 1022 are interposed between the dielectrics 1012 and 1014.

As shown most clearly in FIGURE 12, the patches 1020
20 and 1022 are generally square in shape, each having four corners 1020a and four radiating edges 1020b, each having a length 1020c of about $0.50 \lambda_c$. As viewed in FIG. 12, the patches 1020 and 1022 are electrically interconnected via
25 corners 1020a to an array of substantially parallel horizontal conductive striplines 1024 and an array of substantially parallel vertical conductive striplines 1026 interposed between the dielectric layers 1012 and 1014. A stub 1025 interposed between the dielectric layers 1012 and
30 1014 extends across respective striplines 1024 and 1026 from corners 1020a of each patch 1020 and 1022. A stripline 1027 interposed between the dielectric layers 1012 and 1014 electrically connects each stub 1025 to two closest stubs

1025. A tuning stub 1028 interposed between the dielectric layers 1012 and 1014 extends outwardly from one stub 1025 of each center patch 1022 and toward the center of the antenna 1000 for impedance matching.

5 The patches 1020 and 1022 are preferably spaced apart by a center-to-center distance 1060 of slightly less than $1.0 \lambda_c$. The patches 1020 and 1022 are preferably arranged in a square array on the top surface 1012b having an equal even number of rows and columns (viewed at 45° angles to
10 horizontal in FIGURE 10) of patches 1020 and 1022, exemplified in FIGURE 12, as a square array having four rows and four columns of patches 1020 and 1022 for a total of sixteen patches 1020 and 1022 that constitute the antenna 1000. The width 1084 (FIG. 10) of each stripline 1024, 1026
15 and 1027, and the width and length of each stub 1025 and 1028 is preferably determined assuming a characteristic impedance of about 50 to 200 ohms. A shortening pin (not shown) may optionally be disposed in the antenna 1000 to electrically connect the ground plane 1016 to one or more
20 patches 1020 and/or 1022 to suppress unwanted mode excitations. It should be noted that the use of stubs, such as 1025, in the planar antennas illustrated, provides impedance matching.

For optimal performance at a particular frequency, the
25 dimensions of the patches 1020 and 1022, the striplines 1024, 1026 and 1027, the stubs 1025 and 1028, the apertures 1050, and the center-to-center spacing 1060 are individually calculated so that a high-order standing wave is generated in the antenna cavity formed within the dielectric 1012, and
30 so that fields radiated from the radiating edges 1020b interfere constructively with one another. The number of patches 1020 and 1022 determines not only the overall size, but also the directivity, of the antenna 1000. The sidelobe

levels of the antenna 1000 are determined by the field distribution among the radiating elements 1020 and 1022. Therefore, antenna characteristics, such as directivity and sidelobe levels, are controlled by the size and the position of each of the patches 1020 and 1022 and the feeding scheme. To achieve high directivity, the field distribution among the radiating elements 1020 and 1022 is assumed to be as uniform as possible. There are electric field null points in the dielectric layers 1012 and 1014 within the patches 1020 and 1022 and the connecting striplines 1024 and 1026. The foregoing calculations and analysis utilize techniques, such as the cavity model, discussed, for example, by Lee and Hsieh, and the moment method, discussed, for example, in the software Ensemble™ available from Anasoft Corp., and will, therefore, not be discussed in further detail herein.

Preferably, two conventional SMA probes 1070 are provided for dual-mode operation, such as transmitting and receiving beams. As most clearly shown in FIGURE 11, each SMA probe 1070 includes, for delivering EM energy to and/or from the antenna 1000, an outer conductor 1072 which is electrically connected to the ground plane 1016, and an inner (or feed) conductor 1074 which extends through openings formed in the ground plane 1016 and two center patches 1022, and is electrically connected to a patch 1023. The patch 1023 is preferably square, the sides of which have a length of about 2 millimeters (mm) to about 5 mm and, typically, from about 2.5 mm to about 4.5 mm and, preferably, about 3 mm. The two SMA probes 1070 are thus connected to two selected adjacent center patches 1022. The probes 1070 are positioned along a diagonal of the two selected respective center patches 1022 close to the striplines 1024 and 1026 to optimize the impedance matching of the antenna 1000, and reduce cross-talking and cross-

polarization. While it is preferable that the probes 1070 be SMA probes, any suitable coaxial probe and/or connection arrangement may be used to implement the foregoing connections. For example, a conductive adhesive (not shown) may be used to bond and maintain contact between the inner conductor 1074 and the selected center patches 1022, and an appropriate seal (not shown) may be provided where the SMA probes 1070 pass through the ground plane 1016 to hermetically seal the connection. It is understood that the other ends of the SMA probes 1070, not connected to the antenna 1000, are connectable via a cable (not shown) to a signal generator or to a receiver, such as a satellite signal decoder used with television signals.

In operation, the antenna 1000 may be used for receiving or transmitting linearly polarized (LP) EM beams. To exemplify how the antenna 1000 may be used to receive a beam, the antenna 1000 may be positioned in a residential home and directed for receiving from a geostationary, or equatorial, satellite a beam carrying a television signal within a predetermined frequency band or channel. The antenna 1000 is so directed by orienting the top surface 1012b toward the source of the beam so that it is generally perpendicular to the direction of the beam. Assuming that the elements of the antenna 1000 are correctly sized for receiving the beam, then the beam will pass through the apertures 1050 (FIGURE 11) and induce a standing wave that will resonate within the dielectric layer 1012. A standing wave induced in the resonant cavity defined within the dielectric layer 1012 is communicated through the SMA probes 1070 to a receiver, such as a decoder (not shown).

In the antenna 1000, the vertical modal excitation becomes orthogonal to that of the horizontal mode so that the cross talk between the two input signals will be

minimized. In other words, two orthogonal vertical and horizontal modes can be excited independently.

It is well known that antennas transmit and receive signals reciprocally. It can be appreciated therefore that operation of the antenna 1000 for transmitting signals is reciprocally identical to that of the antenna for receiving signals. The transmission of signals by the antenna 1000 will, therefore, not be further described herein.

It is understood that the present invention can take many forms and embodiments. The embodiments described with respect to FIGURES 10-12 are intended to illustrate rather than to limit the invention. Accordingly, several variations may be made in the foregoing without departing from the spirit or the scope of the invention. For example, additional patches 1020 may be provided for narrowing a beam, or fewer patches 1020 may be utilized to reduce the physical space required for the antenna 1000 of the present invention. In another example, one of the two SMA probes 1070 may be removed (or not attached) for single-mode operation in transmitting and receiving EM beams. The antenna 1000 may also be used for receiving and/or transmitting circularly polarized (CP) EM beams.

FIGURES 13-15

Referring to FIGURES 13-15, the reference numeral 1300 designates, in general, a planar microstrip array antenna embodying features of the present invention for dual-mode operation, such as transmitting and/or receiving EM beams. The antenna 1300 preferably includes generally square, first and second dielectric layers 1312 and 1314. The width 1302 and length 1303 of the layers 1312 and 1314 are determined by the number of patches 1320 and 1322 used, discussed below, and, preferably, extends a width and length 1302a of at least $0.50 \lambda_c$ beyond the outer edges of the patches 1320.

As shown most clearly in FIGURE 14, the dielectric layer 1312 defines a bottom side 1312a to which a conductive ground plane 1316 is bonded, and a top side 1312b to which an array of preferably twelve exterior conductive radiating patches 1320 (FIGURE 13), eight intermediate radiating patches 1321, and four interior radiating patches 1322 are bonded for forming a resonant cavity within the dielectric layer 1312 between the patches 1320, 1321 and 1322, the striplines 1324 and 1352 and the ground plane 1316. The second dielectric 1314 is bonded to the top side 1312b of the dielectric 1312, such that the patches 1320, 1321 and 1322 are interposed between the dielectrics 1312 and 1314.

As shown most clearly in FIGURE 15, the patches 1320, 1321 and 1322 are generally square in shape, each having four corners 1320a and four radiating edges 1320b, each having a length 1320c of about $0.50 \lambda_e$. As viewed in FIG. 15, the patches 1320, 1321 and 1322 are electrically interconnected via corners 1320a through an array of vertical and horizontal (as viewed in FIGS. 13 and 15) conductive striplines 1324 interposed between the dielectric layers 1312 and 1314. An interpatch area 1352 is defined within each space that is circumscribed by the striplines 1324 and that does not contain a patch 1320, 1321 or 1322. A stub 1325 interposed between the dielectric layers 1312 and 1314 extends across respective striplines 1324 into interpatch areas 1352 from each corner 1320a of each patch 1320, 1321 and 1322, that is adjacent to an interpatch area 1352 bounded by at least one interior patch 1322. A stripline 1326 interposed between the dielectric layers 1312 and 1314 electrically connects each stub 1325 to two closest stubs 1325. A tuning stub 1328 interposed between the dielectric layers 1312 and 1314 extends from each stub 1325 of each patch 1321 and 1322 that is adjacent to an

interpatch area 1352 that is bounded by two intermediate patches 1321 and two interior patches 1322, for impedance matching.

The patches 1320, 1321 and 1322 are spaced apart by a center-to-center distance 1360 of preferably approximately 5 $1.0 \lambda_e$. The patches 1320, 1321 and 1322 are preferably arranged in a square array on the top surface 1312b having an equal even number of rows and columns of patches 1320, 1321 and 1322. The width 1384 (FIGURE 13) of each stripline 10 1324 and 1326, and the width and length of each stub 1325 and 1328, is preferably determined assuming a characteristic impedance of about 50 to 200 ohms. A shortening pin (not shown) may optionally be disposed in the antenna 1300 to electrically connect the ground plane 1316 to one or more 15 patches 1320, 1321 and/or 1322 to suppress unwanted mode excitations.

For optimal performance at a particular frequency, the dimensions of the patches 1320, 1321 and 1322, the striplines 1324 and 1326, the stubs 1325 and 1328, the 20 apertures 1350 and areas 1352, and the center-to-center spacing 1360 are individually calculated so that a high-order standing wave is generated in the antenna cavity formed within the dielectric 1312, and so that fields radiated from the radiating edges 1320b interfere 25 constructively with one another. The number of patches 1320, 1321 and 1322 determines not only the overall size, but also the directivity, of the antenna 1300. The sidelobe levels of the antenna 1300 are determined by the field distribution among the radiating elements 1320, 1321 and 30 1322. Therefore, antenna characteristics, such as directivity and sidelobe levels, are controlled by the position of each of the patches 1320, 1321 and 1322 and the feeding scheme. To achieve high directivity, the field

distribution among the radiating elements 1320, 1321 and 1322 is assumed to be as uniform as possible. There are electric field null points within the dielectric layers 1312 between the patches 1320, 1321 and 1322 and the connecting
5 striplines 1324 and 1326 and the ground plane 1316. The foregoing calculations and analysis utilize techniques, such as the cavity model, discussed, for example, by Lee and Hsieh, and the moment method, discussed, for example, in the software Ensemble™ available from Anasoft Corp., and will,
10 therefore, not be discussed in further detail herein.

Preferably, two conventional SMA probes 1370 are provided for dual-mode operation, such as transmitting and receiving beams. As most clearly shown in FIGURE 14, each SMA probe 1370 includes, for delivering EM energy to and/or
15 from the antenna 1300, an outer conductor 1372 which is electrically connected to the ground plane 1316, and an inner (or feed) conductor 1374 which extends through openings formed in the ground plane 1316 and two interior patches 1322, and is electrically connected to a patch 1323.
20 The patch 1323 is preferably square, the sides of which have a length of about 2 mm to about 5 mm and, typically, from about 2.5 mm to about 4.5 mm and, preferably, about 3 mm. The two SMA probes 1370 are thus connected to two adjacent center patches 1322. The probes 1370 are positioned along a
25 diagonal of the two selected respective center patches 1322 proximate to the striplines 1324 to optimize the impedance matching of the antenna 1300, and reduce cross-talking and cross-polarization. While it is preferable that the probes 1370 be SMA probes, any suitable coaxial probe and/or
30 connection arrangement may be used to implement the foregoing connections. For example, a conductive adhesive (not shown) may be used to bond and maintain contact between the inner conductor 1374 and the selected center patches

1322, and an appropriate seal (not shown) may be provided where the SMA probes 1370 pass through the ground plane 1316 to hermetically seal the connection. It is understood that the other ends of the SMA probes 1370, not connected to the antenna 1300, are connectable via a cable (not shown) to a signal generator or to a receiver, such as a satellite signal decoder used with television signals.

In operation, the antenna 1300 may be used for receiving or transmitting linearly polarized (LP) EM beams. To exemplify how the antenna 1300 may be used to receive a beam, the antenna 1300 may be positioned in a residential home and directed for receiving from a geostationary, or equatorial, satellite a beam carrying a television signal within a predetermined frequency band or channel. The antenna 1300 is so directed by orienting the top surface 1312b toward the source of the beam so that it is generally perpendicular to the direction of the beam. Assuming that the elements of the antenna 1300 are correctly sized for receiving the beam, then the beam will pass through the apertures 1350 and areas 1352, and induce a standing wave, which will resonate within the dielectric layer 1312. A standing wave induced in the resonant cavity defined by the dielectric layer 1312 is communicated through the SMA probes 1370 to a receiver, such as a decoder (not shown).

In the antenna 1300, the vertical modal excitation becomes orthogonal to that of the horizontal mode so that the cross talk between the two input signals will be minimized. In other words, two orthogonal vertical and horizontal modes can be excited independently.

It is well known that antennas transmit and receive signals reciprocally. It can be appreciated, therefore, that operation of the antenna 1300 for transmitting signals is reciprocally identical to that of the antenna for

receiving signals. The transmission of signals by the antenna 1300 will, therefore, not be further described herein.

It is understood that the present invention can take many forms and embodiments. The embodiments described with respect to FIGURES 13-15 are intended to illustrate rather than to limit the invention. Accordingly, several variations may be made in the foregoing without departing from the spirit or the scope of the invention. For example, additional patches 1320 may be provided for narrowing a beam, or fewer patches 1320 may be utilized to reduce the physical space required for the antenna 1300 of the present invention. In another example, one of the two SMA probes 1370 may be removed (or not attached) for single-mode operation in transmitting and receiving EM beams. The antenna 1300 may also be used for receiving and/or transmitting circularly polarized (CP) EM beams.

FIGURES 16-18

Referring to FIGURES 16-18, the reference numerals 1600 and 1800 designate, in general, a linear microstrip array antenna embodying features of the present invention for dual-mode operation, such as transmitting and receiving EM beams. The linear array antenna 1600 is configured for producing a narrow beam in the direction of the array, but a broad beam in the direction perpendicular to the array. The antenna 1600 preferably includes a generally rectangular-shaped, dielectric layer 1612. The length 1602 of the layer 1612 is determined by the number of patches 1620 used, discussed below, and, preferably, extends a length 1602a and width 1604a of at least $0.50 \lambda_c$ beyond the outer edges of the patches 1620.

As shown most clearly in FIGURE 17, the dielectric layer 1612 defines a bottom side 1612a to which a conductive

ground plane 1616 is bonded, and a top side 1612b to which an array of conductive radiating patches 1620 (FIGURE 16) and a center radiating patch 1622 are bonded for forming a resonant cavity within the dielectric layer 1612 between the patches 1620 and 1622, striplines 1620, and the ground plane 1616. (Please note that the ground plane 1616 in FIG. 17 has to cover the entire area of the bottom surface of the dielectric slab.)

Referring back to FIGURE 16, the patches 1620 and 1622 are generally square in shape, each having four corners 1620a, and four radiating edges 1620b, each having a length 1620c of about $0.50 \lambda_c$. As viewed in FIG. 16, the patches 1620 and 1622 are electrically interconnected via corners 1620a and crossed conductive striplines 1624 bonded to the dielectric layer 1612. Two tuning stubs 1628 extend diagonally outwardly from two corners 1620a of the center patch 1622, and are also bonded to the dielectric layer 1612. The patches 1620 and 1622 are preferably spaced apart by a center-to-center distance 1660 of slightly less than $1.0 \lambda_c$. The patches 1620 and 1622 are preferably arranged in a single-column array on the top surface 1612b, exemplified in FIG. 16 as having two patches 1620 on each side of a single patch 1622 for a total of five patches 1620 and 1622 that constitute the antenna 1600. The width 1684 (FIG. 16) of each stripline 1624 and the length and width of each stub 1628 are preferably determined assuming a characteristic impedance of about 50 to 200 ohms. A shortening pin 1678 is preferably disposed in the antenna 1600 electrically connecting the ground plane 1616 to the center patch 1622 to suppress unwanted mode excitations. Additional shortening pins (not shown) may also be disposed in the antenna 1600 connecting the ground plane 1616 to patches 1620 to further suppress unwanted mode excitations.

Alternatively, in some instances, it may be preferable to omit one or all shortening pins 1678 from the antenna 1600.

For optimal performance at a particular frequency, the dimensions of the patches 1620 and 1622, the striplines 5 1624, the stubs 1628, the apertures 1650, and the center-to-center spacing 1660 are individually calculated so that a high-order standing wave is generated in the antenna cavity formed within the dielectric 1612, and so that fields radiated from the radiating edges 1620b interfere 10 constructively with one another. The number of patches 1620 and 1622 determines not only the overall size, but also the directivity, of the antenna 1600. The sidelobe levels of the antenna 1600 are determined by the field distribution at the radiating elements 1620 and 1622. Therefore, antenna 15 characteristics, such as directivity and sidelobe levels, are controlled by the size and the position of each of the patches 1620 and 1622 and the feeding scheme. To achieve high directivity, the field distribution at the radiating elements 1620 and 1622 is assumed to be as uniform as possible. The foregoing calculations and analysis utilize 20 techniques, such as the cavity model, discussed, for example, by Lee and Hsieh, and the moment method, discussed, for example, in the software Ensemble™ available from Anasoft Corp., and will, therefore, not be discussed in 25 further detail herein.

Preferably, two conventional SMA probes 1670 are provided for dual-mode operation, such as transmitting and receiving beams. Each SMA probe 1670 includes, for delivering EM energy to and/or from the antenna 1600, an 30 outer conductor 1672 which is electrically connected to the ground plane 1616, and an inner (or feed) conductor 1674 which is electrically connected to the center patch 1622. The probe 1670 is positioned along a diagonal of the patch

1622 close to the stripline 1650 to optimize the impedance matching of the antenna 1600 and reduce cross-talking and cross-polarization. While it is preferable that the probes 1670 be SMA probes, any suitable coaxial probe and/or
5 connection arrangement may be used to implement the foregoing connections. For example, a conductive adhesive (not shown) may be used to bond and maintain contact between the inner conductor 1674 and the center patch 1622, and an appropriate seal (not shown) may be provided where the SMA
10 probe 1670 passes through the ground plane 1616 to hermetically seal the connection. It is understood that the other ends of the SMA probes 1670, not connected to the antenna 1600, are connectable via a cable (not shown) to a signal generator or to a receiver, such as a satellite
15 signal decoder used with television signals.

In operation, the antenna 1600 may be used for receiving or transmitting linearly polarized (LP) EM beams. The antenna 1600 is so directed by orienting the top surface 1612b toward the source of the beam so that it is generally
20 perpendicular to the direction of the beam. Assuming that the elements of the antenna 1600 are correctly sized for receiving the beam, then the beam will pass through the apertures 1650 and induce a standing wave that will resonate within the dielectric layer 1612. A standing wave induced
25 in the resonant cavity defined within the dielectric layer 1612 is communicated through the SMA probe 1670 to a receiver such as a decoder (not shown).

In the antenna 1600, the vertical modal excitation becomes orthogonal to that of the horizontal mode so that
30 the cross talk between the two input signals will be minimized. In other words, two orthogonal vertical and horizontal modes can be excited independently.

It is well known that antennas transmit and receive signals reciprocally. It can be appreciated, therefore, that operation of the antenna 1600 for transmitting signals is reciprocally identical to that of the antenna for receiving signals. The transmission of signals by the antenna 1600 will, therefore, not be further described herein.

It is understood that the present invention can take many forms and embodiments. The embodiments described with respect to FIGURES 16-18 are intended to illustrate rather than to limit the invention. Accordingly, several variations may be made in the foregoing without departing from the spirit or the scope of the invention. For example, additional patches 1620 may be provided for narrowing a beam, or fewer patches 1620 may be utilized to reduce the physical space required for the antenna 1600 of the present invention. The antenna 1600 may also be used for receiving and/or transmitting circularly polarized (CP) EM beams. In a further example, the outer edges of the dielectric layer 1612 may be wrapped with conducting foil, spaced apart from the patches 1620, to thereby form edge conductors and reduce surface-mode excitation and increase the gain of the antenna. In some instances, it may be preferable to omit the shortening pin 1678 from the antenna 1600.

In yet another variation, depicted in FIGURE 18, the antenna 1800 may be adapted for single mode operation in transmitting and receiving EM beams by removing (or not attaching) one of the two SMA probes 1670 and by not bonding one stub 1628 and striplines 1624 that are substantially parallel to the remaining stub 1628.

**VERY-HIGH-GAIN ANTENNA APPLICATIONS (SUCH AS FOR DIRECT
BROADCAST SATELLITE)**

FIGURES 19-20

Referring to FIGURES 19 and 20, the reference numeral
5 1900 designates, in general, a planar microstrip array
antenna embodying features of the present invention for
single-mode operation, such as transmitting or receiving
beams. The antenna 1900 includes a generally square,
dielectric layer 1912. The width 1902 and length 1903 of
10 the layer 1912 may be equal or different, and are determined
by the number of patches used, as discussed below, and,
preferably, extends a width and length 1902a of at least
0.50 λ_c beyond the outer edges of patches 1920.

The dielectric layer 1912 defines a bottom side 1912a
15 to which a conductive ground plane 1916 is bonded, and a top
side 1912b to which an array of conductive radiating patches
1920 are bonded for forming a resonant cavity within the
dielectric layer 1912 between the patches 1920, the
striplines 1924 and the ground plane 1916. The patches 1920
20 are generally square in shape, having four corners 1920a and
four radiating edges 1920b, each having a length 1920c of
about 0.50 λ_c . As viewed in FIGURE 19, the patches 1920 are
electrically interconnected via either one corner 1920a or
two opposing corners 1920a to an array of parallel vertical
25 conductive striplines 1924, which in turn are electrically
interconnected via a horizontal conductive transmission line
1926. The striplines 1924 and transmission line 1926 are
bonded to the dielectric layer 1912. The patches 1920 are
spaced apart by a vertical (as viewed in FIG. 19) center-to-
30 center distance 1960 of preferably about 1 λ_c . The patches
1920 are preferably arranged in a plurality of vertical (as
viewed in FIG. 19) columns on the top surface 1912b,
exemplified in FIG. 19 as eight vertical (as viewed in FIG.

19) columns 1928 (depicted in dashed outline), offset against one another, above and below the horizontal transmission line 1926, each column comprising two patches 1920, for a total of thirty-two patches 1920 that constitute the antenna 1900.

The width 1984 (FIGURE 19) of each stripline 1924 is preferably determined assuming a characteristic impedance of about 50 to 200 ohms. Each transmission line 1926 includes a first portion 1926a, a second portion 1926b and a third portion 1926c. Each first portion 1926a is preferably sized to have a characteristic impedance of about 100 ohms when the input impedance is about 50 ohms. The width and length of each second portion 1926b is determined by a quarter-wavelength transformer, such that the incoming wave from the feed is substantially transmitted, i.e., that the input impedance at a feed line 1974 is properly matched. The width and length of each third portion 1926c of the transmission line 1926 is determined, such that a traveling wave from the feed line 1974 is not reflected at junctions 1927a and 1927b. Accordingly, the length of each third portion 1926c is preferably about $1 \lambda_c$ to ensure that the differences between the phase of the traveling wave at junctions 1927a and 1927b is as close to 360° as possible. The width of each third portion 1926c is preferably sized such that the characteristic impedance is about one half of the characteristic impedance of the striplines 1924.

For optimal performance at a particular frequency, the dimensions of the patches 1920, the striplines 1924 and 1926, the apertures 1950, and the center-to-center spacing 1960 are individually calculated so that a high-order standing wave is generated in the antenna cavity formed within the dielectric 1912, and so that fields radiated from the radiating edges 1920b interfere constructively with one

another. The number of patches 1920 determines not only the overall size, but also the directivity, of the antenna 1900. The sidelobe levels of the antenna 1900 are determined by the field distribution at the radiating edges 1920b.

5 Therefore, antenna characteristics, such as directivity and sidelobe levels, are controlled by the size and the position of each of the patches 1920 and the feeding scheme. To achieve high directivity, the field distribution among the radiating elements 1920 is assumed to be as uniform as possible.

10 There are electric field null points in the dielectric layer 1912. In some instances, one or more shortening pins (not shown) may be disposed in the antenna 1900 electrically connecting together the ground plane, patches, and/or striplines to suppress unwanted mode

15 excitations. The foregoing calculations and analysis utilize techniques, such as the cavity model, discussed, for example, by Lee and Hsieh, and the moment method, discussed, for example, in the software Ensemble™ available from Anasoft Corp., and will, therefore, not be discussed in

20 further detail herein.

A conventional SMA probe 1970 (FIGURE 20) is provided for single mode operation, such as transmitting or receiving beams. The SMA probe 1970 includes, for delivering EM energy to and/or from the antenna 1900, an outer conductor

25 1972 which is electrically connected to the ground plane 1916, and an inner (or feed) conductor 1974 which is electrically connected and centrally positioned along the transmission line 1926 between the portions 1926a to optimize the impedance matching and proper radiation

30 patterns of the antenna 1900. While it is preferable that the probe 1970 be an SMA probe, any suitable coaxial probe and/or connection arrangement may be used to implement the foregoing connections. For example, a conductive adhesive

(not shown) may be used to bond and maintain contact between the inner conductor 1974 and the center patch 1922, and an appropriate seal (not shown) may be provided where the SMA probe 1970 passes through the ground plane 1916 to hermetically seal the connection. It is understood that the other end of the SMA probe 1970, not connected to the antenna 1900, is connectable via a cable (not shown) to a signal generator or to a receiver, such as a satellite signal decoder used with television signals.

In operation, the antenna 1900 may be used for transmitting or receiving linearly polarized (LP) EM beams. In the transmission of an EM beam, an incoming signal from the SMA probe 1970 travels as a traveling wave along the transmission line 1926 through the first portion 1926a which acts as a quarter-wavelength transformer to transport the EM power to the two branches 1926b and 1926c and four striplines 1924 of each branch 1926b and 1926c with minimal reflection. The EM power is transmitted through the striplines 1924 to the array of patches 1920. The patches 1920 and portions of striplines 1924 then induce a high-order standing wave for proper radiation through the apertures 1950 of the antenna 1900.

It is well known that antennas transmit and receive signals reciprocally. It can be appreciated, therefore, that operation of the antenna 1900 for transmitting signals is reciprocally identical to that of the antenna for receiving signals. Thus, for example, the antenna 1900 may be positioned in a residential home and directed for receiving from a geostationary, or equatorial, satellite a beam carrying a television signal within a predetermined frequency band or channel. The antenna 1900 is so directed by orienting the top surface 1912b toward the source of the beam so that it is generally perpendicular to the direction

of the beam. Assuming that the elements of the antenna 1900 are correctly sized for receiving the beam, then the beam will pass through the apertures 1950 and induce a high-order standing wave which will resonate within the resonant cavity formed within the dielectric layer 1912, and pass EM power through the striplines 1924 and transmission lines 1926 to the SMA probe 1970. The EM power is then passed from the SMA probe 1970 through a cable (not shown) and delivered to a receiver, such as a decoder (not shown).

It is understood that the present invention can take many forms and embodiments. The embodiments described with respect to FIGURES 19 and 20 are intended to illustrate rather than to limit the invention. Accordingly, several variations may be made in the foregoing without departing from the spirit or the scope of the invention. For example, additional patches 1920 may be provided for narrowing a beam, or fewer patches 1920 may be utilized to reduce the physical space required for the antenna 1900 of the present invention.

FIGURES 21-22

Referring to FIGURES 21 and 22, the reference numeral 2100 designates, in general, a planar microstrip array antenna embodying features of the present invention for single-mode operation, such as transmitting or receiving beams. The antenna 2100 includes a generally square, dielectric layer 2112. The width 2102 and length 2103 (FIG. 21) of the layer 2112 is determined by the number of patches used, as discussed below, and, preferably, extends a width and length 2102a of at least $0.50 \lambda_c$ beyond the outer edges of patches 2120 and stripline 2126.

The dielectric layer 2112 defines a bottom side 2112a to which a conductive ground plane 2116 is bonded, and a top side 2112b to which an array of conductive radiating patches

2120 are bonded for forming a resonant cavity within the dielectric layer 2112 between the patches 2120, the striplines 2124, and the ground plane 2116. The patches 2120 are generally square in shape, having four corners 2120a and four radiating edges 2120b, each edge having a length 2120c of about $0.50 \lambda_e$. The patches 2120 are electrically interconnected via one corner 2120a to one of an array of four conductive striplines 2124, which in turn are electrically interconnected via a conductive stripline 2126. The striplines 2124 and transmission line 2126 are bonded to the dielectric layer 2112. The patches 2120 are spaced apart by a vertical (as viewed in FIGURE 21) center-to-center distance 2160 of preferably about $1 \lambda_e$. The patches 2120 are preferably arranged in a plurality of eight columns on the top surface 2112b, representatively exemplified in FIG. 21 by columns 2114 and 2116, each of which columns comprises four patches 2120, for a total of thirty-two patches 2120 that constitute the antenna 2100. The width of each stripline 2124 is preferably determined assuming a characteristic impedance of about 50 to 200 ohms. Each transmission line 2126 includes a first portion 2126a preferably configured to have a characteristic impedance of about 100 ohms for an input impedance of about 50 ohms, with a feed line centrally positioned on the stripline 2126, as discussed below with respect to the SMA probe 2170, to ensure proper radiation. Each transmission line 2126 further includes a second portion 2126b preferably configured as a quarter-wavelength transformer to have minimal reflection at the junction with the striplines 2124.

For optimal performance at a particular frequency, the dimensions of the patches 2120, the striplines 2124 and 2126, the apertures 2150, and the center-to-center spacing 2160 are individually calculated so that a high-order

standing wave is generated in the antenna cavity formed within the dielectric 2112, and so that fields radiated from the radiating edges 2120a interfere constructively with one another. The number of patches 2120 determines not only the overall size, but also the directivity, of the antenna 2100. The sidelobe levels of the antenna 2100 are determined by the field distribution among the radiating elements 2120. Therefore, antenna characteristics, such as directivity and sidelobe levels are controlled by the size and the position of each of the patches 2120 and the feeding scheme. To achieve high directivity, the field distribution among the radiating elements 2120 is assumed to be as uniform as possible. There are electric field null points in the dielectric layer 2112 within the patches 2120 and the connecting striplines 2124. In some instances, one or more shortening pins (not shown) may be disposed in the antenna 2100 electrically connecting together the ground plane, patches and/or striplines to suppress unwanted mode excitations. The foregoing calculations and analysis utilize techniques, such as the cavity model, discussed, for example, by Lee and Hsieh, and the moment method, discussed, for example, in the software Ensemble™ available from Anasoft Corp., and will, therefore, not be discussed in further detail herein.

A conventional SMA probe 2170 (FIGURE 22) is provided for single mode operation, such as transmitting or receiving beams. Each SMA probe 2170 includes, for delivering EM energy to and/or from the antenna 2100, an outer conductor 2172 which is electrically connected to the ground plane 2116, and an inner (or feed) conductor 2174 which is electrically connected and centrally positioned along the transmission line 2126 between the portions 2126a and 2126b to optimize the impedance matching of the antenna 2100, and

induce centrally-peaked radiation. While it is preferable that the probe 2170 be an SMA probe, any suitable coaxial probe and/or connection arrangement may be used to implement the foregoing connections. For example, a conductive adhesive (not shown) may be used to bond and maintain contact between the inner conductor 2174 and the center stripline 2126, and an appropriate seal (not shown) may be provided where the SMA probe 2170 passes through the ground plane 2116 to hermetically seal the connection. It is understood that the other end of the SMA probe 2170, not connected to the antenna 2100, is connectable via a cable (not shown) to a signal generator or to a receiver, such as a satellite signal decoder used with television signals.

In operation, the antenna 2100 may be used for transmitting or receiving linearly polarized (LP) EM beams. In the transmission of an EM beam, an incoming signal from the SMA probe 2170 travels as a traveling wave along the transmission line 2126 through the first portion 2126a and the second portion 2126b, which behaves as a quarter-wavelength transformer to transport the EM power to the four striplines 2124 with minimal reflection. The EM power is transmitted through the striplines 2124 to the array of patches 2120. The patches 2120 then induce a high-order standing wave for proper radiation through the apertures 2150 of the antenna 2100.

It is well known that antennas transmit and receive signals reciprocally. It can be appreciated, therefore, that operation of the antenna 2100 for transmitting signals is reciprocally identical to that of the antenna for receiving signals. Thus, for example, the antenna 2100 may be positioned in a residential home and directed for receiving from a geostationary, or equatorial, satellite a beam carrying a television signal within a predetermined

frequency band or channel. The antenna 2100 is so directed by orienting the top surface 2112b toward the source of the beam so that it is generally perpendicular to the direction of the beam. Assuming that the elements of the antenna 2100
5 are correctly sized for receiving the beam, then the beam will pass through the apertures 2150 and induce a standing wave that will resonate within the dielectric layer 2112. A standing wave induced in the resonant cavity defined within the dielectric layer 2112 is transmitted through striplines
10 2124, transmission line 2126, and the SMA probe 2170 and is delivered to a receiver, such as a decoder (not shown).

It is understood that the present invention can take many forms and embodiments. The embodiments described with respect to FIGURES 21 and 22 are intended to illustrate
15 rather than to limit the invention. Accordingly, several variations may be made in the foregoing without departing from the spirit or the scope of the invention. For example, additional patches 2120 may be provided for narrowing a beam, or fewer patches 2120 may be utilized to reduce the
20 physical space required for the antenna 2100 of the present invention.

FIGURES 23-24

Referring to FIGURES 23 and 24, the reference numeral 2300 designates, in general, a planar microstrip array
25 antenna embodying features of the present invention for dual-mode operation, such as transmitting and receiving beams. The antenna 2300 includes a generally square, dielectric layer 2312. The width 2302 and length 2303 (FIG. 23) of the layer 2312 is determined by the number of patches
30 used, as discussed below, and, preferably, extends a width and length 2302a of at least $0.50 \lambda_c$ beyond the outer edges of the patches 2320 and transmission lines 2325 and 2327.

The dielectric layer 2312 defines a bottom side 2312a to which a conductive ground plane 2316 is bonded, and a top side 2312b to which an array of conductive radiating patches 2320 are bonded for forming a resonant cavity within the dielectric layer 2312 between the patches 2320, the striplines 2324 and 2326, and the ground plane 2316. The patches 2320 are generally square in shape, having four corners 2320a and four radiating edges 2320b, each edge having a length 2320c of about $0.50 \lambda_e$. As viewed in FIGURE 23, the patches 2320 are electrically interconnected via two adjacent corners 2320a, one of which adjacent corners is electrically connected to one of an array of eight vertical conductive striplines 2324, and the other of which adjacent corners is electrically connected to one of an array of eight horizontal conductive striplines 2326. The vertical striplines 2324 are electrically interconnected via a horizontal conductive transmission line 2325, and the horizontal striplines 2326 are electrically interconnected via a vertical conductive transmission line 2327. The striplines 2324 and 2326 and the transmission lines 2325 and 2327 are bonded to the dielectric layer 2312. The patches 2320 are spaced apart by a center-to-center distance 2360 of preferably about $1 \lambda_e$. The patches 2320 are preferably arranged in a plurality of rows and columns on the top surface 2312b, representatively exemplified in FIG. 23 by a row 2328 and a column 2329, wherein each row and column comprises four patches 2320, for a total of thirty-two patches 2320 that constitute the antenna 2300. The width of each stripline 2324 is preferably determined assuming a characteristic impedance of about 50 to 200 ohms. Each transmission line 2325 and 2327 includes a first portion 2326a and 2326a, preferably configured to have a characteristic impedance of about 100 ohms for an input

impedance of about 50 ohms, with a feed line centrally positioned on the stripline 2325, as discussed below with respect to the SMA probe 2370, to ensure proper radiation. Each transmission line 2325 and 2327 further includes a
5 second portion 2325b and 2327b preferably configured as a quarter-wavelength transformer to have minimal reflection at the junction with the striplines 2324 and 2326.

For optimal performance at a particular frequency, the dimensions of the patches 2320, the striplines 2324 and
10 2326, the apertures 2350, and the center-to-center spacing 2360 are individually calculated so that a high-order standing wave is generated in the antenna cavity formed within the dielectric 2312, and so that fields radiated from the radiating edges 2320b interfere constructively with one
15 another.

The number of patches 2320 determines not only the overall size, but also the directivity, of the antenna 2300. The sidelobe levels of the antenna 2300 are determined by the field distribution among the radiating elements 2320.
20 Therefore, antenna characteristics, such as directivity and sidelobe levels, are controlled by the size and the position of each of the patches 2320 and the feeding scheme. To achieve high directivity, the field distribution among the radiating elements 2320 is assumed to be as uniform as
25 possible. There are electric field null points in the dielectric layer 2312 between the ground plane 2316 on the one hand, and the patches 2320 and striplines 2324 and 2326 on the other hand. In some instances, one or more shortening pins (not shown) may be disposed in the antenna
30 2300 electrically connecting together the ground plane, patches, and/or striplines to suppress unwanted mode excitations. The foregoing calculations and analysis utilize techniques, such as the cavity model, discussed, for

example, by Lee and Hsieh, and the moment method, discussed, for example, in the software Ensemble™ available from Anasoft Corp., and will, therefore, not be discussed in further detail herein.

5 Two conventional SMA probes 2370 (FIGURE 24) are provided for dual-mode operation, such as transmitting and receiving beams. Each SMA probe 2370 includes, for delivering EM energy to and/or from the antenna 2300, an outer conductor 2372 which is electrically connected to the
10 ground plane 2316, and an inner (or feed) conductor 2374 which is electrically connected and centrally positioned along each transmission line 2325 and 2327 to optimize the impedance matching of the antenna 2300 and the radiation efficiency. While it is preferable that the probes 2370 be
15 SMA probes, any suitable coaxial probe and/or connection arrangement may be used to implement the foregoing connections. For example, a conductive adhesive (not shown) may be used to bond and maintain contact between each inner conductor 2374 and each transmission line 2325 and 2327, and
20 an appropriate seal (not shown) may be provided where the SMA probe 2370 passes through the ground plane 2316 to hermetically seal the connection. It is understood that the other end of the SMA probe 2370, not connected to the antenna 2300, is connectable via a cable (not shown) to a
25 signal generator or to a receiver, such as a satellite signal decoder used with television signals.

In operation, the antenna 2300 may be used for transmitting and/or receiving linearly polarized (LP) EM beams. In the transmission of an EM beam, exemplified with
30 a signal from the SMA probe 2370 to the transmission line 2325, the incoming signal travels as a traveling wave along the transmission line 2325 through the first portion 2325a and the second portion 2325b, which behaves as a quarter-

wavelength transformer to transport the EM power to the four striplines 2324 with minimal reflection. The EM power is transmitted through the striplines 2324 to the array of patches 2320. The patches 2320 then induce a high-order
5 standing wave for proper radiation through the apertures 2350 of the antenna 2300.

In the antenna 2300, the vertical modal excitation becomes orthogonal to that of the horizontal mode so that the cross talk between the two input signals will be
10 minimized. In other words, two orthogonal vertical and horizontal modes can be excited independently.

It is well known that antennas transmit and receive signals reciprocally. It can be appreciated, therefore, that operation of the antenna 2300 for transmitting signals
15 is reciprocally identical to that of the antenna for receiving signals. Thus, for example, the antenna 2300 may be positioned in a residential home and directed for receiving from a geostationary, or equatorial, satellite a beam carrying a television signal within a predetermined
20 frequency band or channel. The antenna 2300 is so directed by orienting the top surface 2312b toward the source of the beam so that it is generally perpendicular to the direction of the beam. Assuming that the elements of the antenna 2300 are correctly sized for receiving the beam, then the beam
25 will pass through the apertures 2350 and induce a standing wave that will resonate within the dielectric layer 2312. A standing wave induced in the resonant cavity defined within the dielectric layer 2312 is transmitted either through the striplines 2324 and transmission line 2325, and/or through
30 the striplines 2326 and transmission line 2327, to an SMA probe 2370 and delivered to a receiver, such as a decoder (not shown). It is well known that antennas transmit and receive signals reciprocally. It can be appreciated,

therefore, that operation of the antenna 2300 for transmitting signals is reciprocally identical to that of the antenna for receiving signals. The transmission of signals by the antenna 2300 will, therefore, not be further
5 described herein.

It is understood that the present invention can take many forms and embodiments. The embodiments described with respect to FIGURES 23 and 24 are intended to illustrate rather than to limit the invention. Accordingly, several
10 variations may be made in the foregoing without departing from the spirit or the scope of the invention. For example, additional patches 2320 may be provided for narrowing a beam, or fewer patches 2320 may be utilized to reduce the physical space required for the antenna 2300 of the present
15 invention. With proper modification near the feeding area, dual-mode operation with two orthogonal circular polarizations (CP) can be achieved.

FIGURES 25-26

Referring to FIGURES 25 and 26, the reference numeral
20 2500 designates, in general, a planar microstrip array antenna embodying features of the present invention for single-mode operation, such as transmitting or receiving beams. The antenna 2500 includes a generally square, dielectric layer 2512. The width 2502 and length 2503 of
25 the layer 2512 may be equal or unequal and are determined by the number of patches used, as discussed below, and, preferably, extends a width and length 2502a of at least $0.50 \lambda_c$ beyond the outer edges of patches 2520.

The dielectric layer 2512 defines a bottom side 2512a
30 to which a conductive ground plane 2516 is bonded, and a top side 2512b to which an array of conductive radiating patches 2520 are bonded for forming a resonant cavity within the dielectric layer 2512, between the ground plane 2516 and the

patches 2520 and striplines 2524. The patches 2520 are generally square in shape, having four corners 2520a and four radiating edges 2520b, each having a length 2520c of about $0.5 \lambda_e$. As viewed in FIGURE 25, the patches 2520 are electrically interconnected via either one corner 2520a or two opposing corners 2520a to an array of substantially parallel vertical conductive striplines 2524, which in turn are electrically interconnected via a substantially horizontal conductive transmission line 2526, which striplines 2524 and transmission line 2526 are bonded to the dielectric layer 2512. The patches 2520 are spaced apart by a vertical (as viewed in FIG. 25) center-to-center distance 2560 of preferably about $1 \lambda_e$. The patches 2520 are preferably arranged in a plurality of vertical (as viewed in FIG. 25) columns on the top surface 2512b, above and below the transmission line 2526, representatively exemplified by a column 2528, depicted in dashed outline. The width of each stripline 2524 is preferably determined assuming a characteristic impedance of about 50 to 200 ohms. The transmission line 2526 includes a first portion 2526a preferably configured to have a characteristic impedance of about 100 ohms for an input impedance of about 50 ohms, with a feed line preferably centrally positioned on the transmission line 2526, as discussed below with respect to the SMA probe 2570, to ensure proper radiation. The transmission line 2526 further includes two second portions 2526b so configured to have minimal reflection at the junction with the striplines 2524.

For optimal performance at a particular frequency, the dimensions of the patches 2520, the striplines 2524, the transmission line 2526, the apertures 2550, and the center-to-center spacing 2560 are individually calculated so that a high-order standing wave is generated in the antenna cavity

formed within the dielectric 2512, and so that fields radiated from the radiating edges 2520b interfere constructively with one another. The number of patches 2520 determines not only the overall size, but also the directivity, of the antenna 2500. The sidelobe levels of the antenna 2500 are determined by the field distribution among the radiating elements 2520. Therefore, antenna characteristics, such as directivity and sidelobe levels, are controlled by the size and the position of each of the patches 2520 and the feeding scheme. To achieve high directivity, the field distribution at the radiating elements 2520 is assumed to be as uniform as possible. There are electric field null points in the dielectric layer 2512 proximal to the patches 2520 and striplines 2524. In some instances, one or more shortening pins (not shown) may be disposed in the antenna 2500 electrically connecting together the ground plane, patches, and/or striplines to suppress unwanted mode excitations. The foregoing calculations and analysis utilize techniques, such as the cavity model, discussed, for example, by Lee and Hsieh, and the moment method, discussed, for example, in the software Ensemble™ available from Anasoft Corp., and will, therefore, not be discussed in further detail herein.

A conventional SMA probe 2570 (FIGURE 26) is provided for single-mode operation, such as transmitting or receiving beams. Each SMA probe 2570 includes, for delivering EM energy to or from the antenna 2500, an outer conductor 2572 which is electrically connected to the ground plane 2516, and an inner (or feed) conductor 2574 which is electrically connected and centrally positioned along the transmission line 2526 to optimize the impedance matching of the antenna 2500, and the antenna aperture efficiency. While it is preferable that the probe 2570 be an SMA probe, any suitable

coaxial probe and/or connection arrangement may be used to implement the foregoing connections. For example, a conductive adhesive (not shown) may be used to bond and maintain contact between the inner conductor 2574 and the center stripline 2526a, and an appropriate seal (not shown) may be provided where the SMA probe 2570 passes through the ground plane 2516 to hermetically seal the connection. It is understood that the other end of the SMA probe 2570, not connected to the antenna 2500, is connectable via a cable (not shown) to a signal generator or to a receiver, such as a satellite signal decoder used with television signals.

In operation, the antenna 2500 may be used for transmitting or receiving linearly polarized (LP) EM beams. In the transmission of an EM beam, exemplified using a signal from the SMA probe 2570 to the transmission line 2526, the incoming signal travels as a traveling wave along the transmission line 2526 through the first portion 2526a to transport the EM power to the two branches 2526b and, subsequently, striplines 2524 with minimal reflection. The EM power is transmitted through the striplines 2524 to the array of patches 2520. The patches 2520 then induce a high-order standing wave for proper radiation through the apertures 2550 of the antenna 2500.

It is well known that antennas transmit and receive signals reciprocally. It can be appreciated, therefore, that operation of the antenna 2500 for transmitting signals is reciprocally identical to that of the antenna for receiving signals. Thus, for example, the antenna 2500 may be positioned in a residential home and directed for receiving from a geostationary, or equatorial, satellite a beam carrying a television signal within a predetermined frequency band or channel. The antenna 2500 is so directed by orienting the top surface 2512b toward the source of the

beam so that it is generally perpendicular to the direction of the beam. Assuming that the elements of the antenna 2500 are correctly sized for receiving the beam, then the beam will pass through the apertures 2550 and induce a standing wave that will resonate within the resonant cavity of the array of patches 2520 in the dielectric layer 2512. A standing wave induced in the resonant cavity defined in the dielectric layer 2512 leaks the EM power through the transmission line network comprising the striplines 2524 and 2526 to the SMA probe 2570, and is delivered to a receiver, such as a decoder (not shown). It is well known that antennas transmit and receive signals reciprocally. It can be appreciated, therefore, that operation of the antenna 2500 for transmitting signals is reciprocally identical to that of the antenna for receiving signals. The transmission of signals by the antenna 2500 will, therefore, not be further described herein.

It is understood that the present invention can take many forms and embodiments. The embodiments described with respect to FIGURES 25 and 26 are intended to illustrate rather than to limit the invention. Accordingly, several variations may be made in the foregoing without departing from the spirit or the scope of the invention. For example, additional patches 2520 may be provided for narrowing a beam, or fewer patches 2520 may be utilized to reduce the physical space required for the antenna 2500 of the present invention.

FIGURES 27-28

Referring to FIGURES 27 and 28, the reference numeral 2700 designates, in general, a planar microstrip array antenna embodying features of the present invention for single-mode operation, such as transmitting or receiving beams. The antenna 2700 includes a generally square,

dielectric layer 2712. The width 2702 and length 2703 of the layer 2712 may be equal or unequal, and are determined by the number of patches used, discussed below, and, preferably, extends a width and length 2702a of at least
5 0.50 λ_c beyond the outer edges of patches 2720.

Referring to FIGURE 28, the dielectric layer 2712 defines a bottom side 2712a to which a conductive ground plane 2716 is bonded and a top side 2712b to which an array of conductive radiating patches 2720 (FIGURE 27) are bonded
10 for forming a resonant cavity within the dielectric layer 2712, between the ground plane and the patches 2720 and striplines 2724.

Referring back to FIGURE 27, the patches 2720 are generally square in shape, having four corners 2720a and
15 four radiating edges 2720b, each having a length 2720c of about 0.5 λ_c . As viewed in FIG. 27, the patches 2720 are electrically interconnected via two, three or four corners 2720a to an array of substantially horizontal and vertical conductive striplines 2724, which in turn are electrically
20 interconnected via a substantially horizontal conductive transmission line 2726. The striplines 2724 and transmission line 2726 are bonded to the dielectric layer 2712. The width of each stripline 2724 is preferably determined assuming a characteristic impedance of about 50
25 to 200 ohms. The transmission line 2726 includes a first portion 2726a preferably configured to have a characteristic impedance of about 100 ohms for an input impedance of about 50 ohms, with a feed line 2774 centrally positioned on the transmission line 2726, as discussed below with respect to
30 the SMA probe 2770, to ensure proper radiation. The transmission line 2726 further includes two second portions 2726b preferably configured as quarter-wavelength transformers to have minimal reflection. Then the signal

from 2726b travels through further quarter-wavelength transformers, such that the power through the vertical transmission lines 2724 are equally distributed among one another.

5 For optimal performance at a particular frequency, the dimensions of the patches 2720, the striplines 2724 and transmission line 2726, the apertures 2750, and the center-to-center spacing 2760 are individually calculated so that a high-order standing wave is generated in the antenna cavity
10 formed within the dielectric 2712, and so that fields radiated from the radiating edges 2720b interfere constructively with one another.

The number of patches 2720 determines not only the overall size, but also the directivity, of the antenna 2700.
15 The sidelobe levels of the antenna 2700 are determined by the field distribution at the radiating edges 2720b. Therefore, antenna characteristics, such as directivity and sidelobe levels, are controlled by the size and the position of each of the patches 2720 and the feeding scheme. To
20 achieve high directivity, the field distribution among the radiating elements 2720 is assumed to be as uniform as possible. There are electric field null points in the dielectric layer 2712 proximal to the patches 2720 and striplines 2724. In some instances, one or more shortening
25 pins (not shown) may be disposed in the antenna 2700 electrically connecting together the ground plane, patches, and/or striplines to suppress unwanted mode excitations. The foregoing calculations and analysis utilize techniques, such as the cavity model, discussed, for example, by Lee and
30 Hsieh, and the moment method, discussed, for example, in the software Ensemble™ available from Anasoft Corp., and will, therefore, not be discussed in further detail herein.

A conventional SMA probe 2770 (FIGURE 28) is provided for single-mode operation, such as transmitting or receiving beams. The SMA probe 2770 includes, for delivering EM energy to or from the antenna 2700, an outer conductor 2772 which is electrically connected to the ground plane 2716, and an inner (or feed) conductor 2774 which is electrically connected and centrally positioned along the transmission line 2726 for proper radiation. While it is preferable that the probe 2770 be an SMA probe, any suitable coaxial probe and/or connection arrangement may be used to implement the foregoing connections. For example, a conductive adhesive (not shown) may be used to bond and maintain contact between the inner conductor 2774 and the center stripline 2726a, and an appropriate seal (not shown) may be provided where the SMA probe 2770 passes through the ground plane 2716 to hermetically seal the connection. It is understood that the other end of the SMA probe 2770, not connected to the antenna 2700, is connectable via a cable (not shown) to a signal generator or to a receiver, such as a satellite signal decoder used with television signals.

In operation, the antenna 2700 may be used for transmitting or receiving linearly polarized (LP) EM beams. In the transmission of an EM beam, exemplified using a signal from the SMA probe 2770 to the transmission line 2726, the incoming signal travels as a traveling wave along the transmission line 2726 through the first portions 2726a, the second portions 2726b, which behave as a quarter-wavelength transformer, and then through further quarter-wavelength transformers and power dividers to transport the EM power ultimately to striplines 2724 with minimal reflection and relatively uniform power distribution among the vertical striplines 2724. The EM power is transmitted through the striplines 2724 to the array of patches 2720.

The patches 2720 then induce a high-order standing wave for proper radiation through the radiating edges 2720b of each patch 2720 of the antenna 2700.

It is well known that antennas transmit and receive
5 signals reciprocally. It can be appreciated, therefore, that operation of the antenna 2700 for transmitting signals is reciprocally identical to that of the antenna for receiving signals. Thus, for example, the antenna 2700 may be positioned in a residential home and directed for
10 receiving from a geostationary, or equatorial, satellite a beam carrying a television signal within a predetermined frequency band or channel. The antenna 2700 is so directed by orienting the top surface 2712b toward the source of the beam so that it is generally perpendicular to the direction
15 of the beam. Assuming that the elements of the antenna 2700 are correctly sized for receiving the beam, then the beam will pass through the apertures 2750 and induce a standing wave that will resonate within the resonant cavity of the array of patches 2720 in the dielectric layer 2712. A
20 standing wave induced in the resonant cavity defined in the dielectric layer 2712 leaks EM power through the transmission line network comprising the striplines 2724 and 2726 to the SMA probe 2770, and is delivered to a receiver, such as a decoder (not shown). It is well known that
25 antennas transmit and receive signals reciprocally. It can be appreciated, therefore, that operation of the antenna 2700 for transmitting signals is reciprocally identical to that of the antenna for receiving signals. The transmission of signals by the antenna 2700 will, therefore, not be
30 further described herein.

It is understood that the present invention can take many forms and embodiments. The embodiments described with respect to FIGURES 27 and 28 are intended to illustrate

rather than to limit the invention. Accordingly, several variations may be made in the foregoing without departing from the spirit or the scope of the invention. For example, additional patches 2720 may be provided for narrowing a beam, or fewer patches 2720 may be utilized to reduce the physical space required for the antenna 2700 of the present invention.

FIGURES 29-31

Referring to FIGURES 29A and 29B (hereinafter "FIGURE 29") and FIGURE 30, the reference numeral 2900 designates, in general, a planar microstrip array antenna embodying features of the present invention for dual-mode operation, such as transmitting or receiving beams. The antenna 2900 includes a generally square, dielectric layer 2912. The width 2902 and length 2903 of the layer 2912 may be equal or unequal, and are determined by the number of patches used, discussed below, and, preferably, extends a width and length 2902a of at least $0.50 \lambda_c$ beyond the outer edges of patches 2920.

Referring to FIGURE 30, the dielectric layer 2912 defines a bottom side 2912a to which a conductive ground plane 2916 is bonded, and a top side 2912b to which an array of conductive radiating patches 2920 (FIGURE 29) are bonded for forming a resonant cavity within the dielectric layer 2912, between the ground plane 2916 and the patches 2920 and striplines 2924.

Referring back to FIGURE 29, the patches 2920 are generally square in shape, having four corners 2920a and four radiating edges 2920b, each having a length 2920c of about $0.5 \lambda_c$. As viewed in FIG. 29, the patches 2920 are electrically interconnected via two, three or four corners 2920a to an array of substantially horizontal and vertical conductive striplines 2924, which are bonded to the

dielectric layer 2912. The striplines 2924 are in turn electrically interconnected via a substantially horizontal conductive transmission line 2926 and a substantially vertical conductive transmission line 2928. The transmission lines 2926 and 2928 are bonded to the dielectric layer 2912, and the intersection of the transmission lines 2926 and 2928 is denoted in FIG. 29 by dashed outline 2927, described further below with respect to FIGURE 30. The width of each stripline 2924 is preferably determined assuming a characteristic impedance of about 50 to 200 ohms. The transmission lines 2926 and 2928 include first portions 2926a and 2928a, respectively, preferably configured to have a characteristic impedance of about 100 ohms for an input impedance of about 50 ohms, with a feed line 2974 positioned on each of the transmission lines 2926 and 2928, as discussed below with respect to the SMA probe 2970, to ensure proper radiation. Each of the transmission lines 2926 and 2928 further includes two second portions 2926b and 2928b, respectively, preferably configured as quarter-wavelength transformers to have minimal reflection.

FIGURE 30 depicts one preferred configuration wherein the transmission lines 2926 and 2928 may intersect at the dashed outline 2927 without electrical contact. Accordingly, as viewed in FIG. 30, the transmission line 2928 includes a bridge comprising two vias 2928c by which it passes under the transmission line 2926, wherein the two vias 2928c pass through openings in the ground plane 2916 without electrically contacting the ground plane 2916, and which in turn are electrically connected by a microstrip 2928d (FIGURE 31) which is electrically insulated from the ground plane 2916 via a dielectric 2913. In an alternative embodiment, the non-conductive intersection of the transmission lines 2926 and 2928 may be achieved by using a

directional coupler, described below with respect to FIGS. 31 and 32.

For optimal performance at a particular frequency, the dimensions of the patches 2920, the transmission lines 2924 and 2926, the apertures 2950, and the center-to-center spacing 2960 are individually calculated so that a high-order standing wave is generated in the antenna cavity formed within the dielectric 2912, and so that fields radiated from the radiating edges 2920b interfere constructively with one another.

The number of patches 2920 determines not only the overall size, but also the directivity, of the antenna 2900. The sidelobe levels of the antenna 2900 are determined by the field distribution among the radiating elements 2920. Therefore, antenna characteristics, such as directivity and sidelobe levels, are controlled by the size and the position of each of the patches 2920 and the feeding scheme. To achieve high directivity, the field distribution among the radiating elements 2920 is assumed to be as uniform as possible. There are electric field null points in the dielectric layer 2912 proximal to the patches 2920 and striplines 2924. In some instances, one or more shortening pins (not shown) may be disposed in the antenna 2900 electrically connecting together the ground plane, patches, and/or striplines to suppress unwanted mode excitations. The foregoing calculations and analysis utilize techniques, such as the cavity model, discussed, for example, by Lee and Hsieh, and the moment method, discussed, for example, in the software Ensemble™ available from Anasoft Corp., and will, therefore, not be discussed in further detail herein.

Two conventional SMA probes 2970 (FIGURE 30) are provided for dual-mode operation, such as transmitting and receiving beams. Each SMA probe 2970 includes, for

delivering EM energy to or from the antenna 2900, an outer conductor 2972 which is electrically connected to the ground plane 2916, and an inner (or feed line) conductor 2974 which is electrically connected and positioned along the transmission lines 2926 and 2928 to optimize the impedance matching of the antenna 2900. Preferably, the feed lines 2974 are spaced a distance 2975 of about a quarter-wavelength plus multiple of λ_c off-center from where the transmission lines 2926 and 2928 intersect, as indicated within dashed outline 2927 (FIGURE 29). While it is preferable that the probes 2970 be SMA probes, any suitable coaxial probe and/or connection arrangement may be used to implement the foregoing connections. For example, a conductive adhesive (not shown) may be used to bond and maintain contact between the feed line 2974 and the center stripline 2926a, and an appropriate seal (not shown) may be provided where the SMA probe 2970 passes through the ground plane 2916 to hermetically seal the connection. It is understood that the other end of the SMA probe 2970, not connected to the antenna 2900, is connectable via a cable (not shown) to a signal generator or to a receiver such as a satellite signal decoder used with television signals.

In operation, the antenna 2900 may be used for transmitting and/or receiving linearly polarized (LP) EM beams. In the transmission of an EM beam, exemplified using signals from the SMA probes 2970 to the transmission lines 2926 and 2928, the incoming signal travels as a traveling wave along the transmission lines 2926 and 2928 through the first portions 2926a and 2928a, respectively, to transport the EM power to the two branches 2926b and 2928b and subsequently striplines 2924 with minimal reflection. The EM power is transmitted through the striplines 2924 to the array of patches 2920. The patches 2920 and portions of the

striplines 2924 then induce a high-order standing wave for proper radiation through the apertures 2950 of the antenna 2900.

5 In the antenna 2900, the vertical modal excitation becomes orthogonal to that of the horizontal mode so that the cross talk between the two input signals will be minimized. In other words, two orthogonal vertical and horizontal modes can be excited independently.

10 It is well known that antennas transmit and receive signals reciprocally. It can be appreciated, therefore, that operation of the antenna 2900 for transmitting signals is reciprocally identical to that of the antenna for receiving signals. Thus, for example, the antenna 2900 may be positioned in a residential home and directed for
15 receiving from a geostationary, or equatorial, satellite a beam carrying a television signal within a predetermined frequency band or channel. The antenna 2900 is so directed by orienting the top surface 2912b toward the source of the beam so that it is generally perpendicular to the direction
20 of the beam. Assuming that the elements of the antenna 2900 are correctly sized for receiving the beam, then the beam will pass through the apertures 2950 and induce a standing wave that will resonate within the resonant cavity in the dielectric layer 2912 between the array of patches 2920 and
25 the striplines 2924 and the ground plane 2916. A standing wave induced in the resonant cavity defined in the dielectric layer 2912 is transmitted through the transmission line network comprising the striplines 2924 and 2926 to the SMA probes 2970 and is delivered to a receiver,
30 such as a decoder (not shown). It is well known that antennas transmit and receive signals reciprocally. It can be appreciated, therefore, that operation of the antenna 2900 for transmitting signals is reciprocally identical to

that of the antenna for receiving signals. The transmission of signals by the antenna 2900 will, therefore, not be further described herein.

It is understood that the present invention can take many forms and embodiments. The embodiments described with respect to FIGURES 29 and 30 are intended to illustrate rather than to limit the invention. Accordingly, several variations may be made in the foregoing without departing from the spirit or the scope of the invention. For example, additional patches 2920 may be provided for narrowing a beam, or fewer patches 2920 may be utilized to reduce the physical space required for the antenna 2900 of the present invention. With proper modification near the feeding area, dual-mode operation with two orthogonal circular polarizations (CP) can be achieved.

FIGURES 32-33

Referring to FIGURES 32 and 33, the reference numeral 3200 designates, in general, a planar microstrip array antenna embodying features of the present invention for dual-mode operation, such as transmitting and receiving beams. The antenna 3200 includes a generally square, dielectric layer 3212. The width 3202 and length 3203 (FIGURE 32) of the layer 3212 may be equal or different, and are determined by the number of patches used, as discussed below, and, preferably, extends a width and length 3202a of at least $0.50 \lambda_c$ beyond the outer edges of patches 3220.

Referring to FIGURE 33, the dielectric layer 3212 defines a bottom side 3212a to which a conductive ground plane 3216 is bonded, and a top side 3212b to which an array of conductive radiating patches 3220 are bonded for forming a resonant cavity within the dielectric layer 3212, between the patches 3220, the striplines 3224 and 3226, and the ground plane 3216. Referring to FIGURE 32, the patches 3220

are generally square in shape, having four corners 3220a and four radiating edges 3220b, each having a length 3220c of about $0.5 \lambda_c$. As viewed in FIG. 32, the patches 3220 are electrically interconnected via corners 3220a to an array of substantially vertical conductive striplines 3224 and horizontal conductive striplines 3226. The striplines 3224 and 3226 are electrically interconnected via respective transmission lines 3224a, 3224b, 3226a, and 3226b to a directional coupling 3400, described in further detail below with respect to FIGURE 34, for communicating EM energy with a probe, described in further detail with respect to the SMA probes 3270. The striplines 3224, 3226, and transmission lines 3224a, 3224b, 3226a, and 3226b are bonded to the dielectric layer 3212. The patches 3220 are spaced apart by a center-to-center distance 3260 of preferably about $1 \lambda_c$. The patches 3220 are preferably arranged in four sub-arrays and, within each sub-array, into a plurality of rows and columns on the top surface 3212b, representatively exemplified in dashed outlines by a sub-array 3222 having rows 3228 and columns 3229 offset from each other. The width of each stripline 3224 and 3226 is preferably determined assuming a characteristic impedance of about 50 to 200 ohms. The transmission lines 3224a and 3226a are preferably configured to have a characteristic impedance of about 100 ohms for an input impedance of about 50 ohms, with a feed line positioned on the striplines 3224 and 3226, as discussed below with respect to the SMA probes 3270, to ensure a proper phase for each stripline and patch so that an optimum gain results. The transmission lines 3224b and 3226b are preferably configured as two quarter-wavelength transformers in series to have minimal reflection.

For optimal performance at a particular frequency, the dimensions of the patches 3220, the striplines 3224, 3226,

and the apertures 3250, the center-to-center spacing 3260, and the coupler 3100 are individually calculated so that a high-order standing wave is generated in the antenna cavity formed by the dielectric 3212, and so that fields radiated from the radiating edges 3220b interfere constructively with one another.

The number of patches 3220 determines not only the overall size, but also the directivity, of the antenna 3200. The sidelobe levels of the antenna 3200 are determined by the field distribution among the radiating elements 3220. Therefore, antenna characteristics, such as directivity and sidelobe levels, are controlled by the size and the position of each of the patches 3220 and the feeding scheme. To achieve high directivity, the field distribution among the radiating elements 3220 is assumed to be as uniform as possible. There are electric field null points in the dielectric layer 3212 within the patches 3220 and striplines 3224 and 3226. In some instances, one or more shortening pins (not shown) may be disposed in the antenna 3200 electrically connecting together the ground plane, patches, and/or striplines to suppress unwanted mode excitations. The foregoing calculations and analysis utilize techniques, such as the cavity model, discussed, for example, by Lee and Hsieh, and the moment method, discussed, for example, in the software Ensemble™ available from Anasoft Corp., and will, therefore, not be discussed in further detail herein.

Two conventional SMA probes 3270 (only one of which is shown in FIGURE 33) are provided for dual-mode operation, such as transmitting and receiving beams. Each SMA probe 3270 includes, for delivering EM energy to and/or from the antenna 3200, an outer conductor 3272 which is electrically connected to the ground plane 3216, and an inner (or feed) conductor 3274 which is electrically connected to and

positioned along a respective transmission line 3224a or 3226a to ensure a proper phase for each stripline and patch so that an optimum gain results. While it is preferable that the probes 3270 be SMA probes, any suitable coaxial probe and/or connection arrangement may be used to implement
5 the foregoing connections. For example, a conductive adhesive (not shown) may be used to bond and maintain contact between an inner conductor 3274 and the transmission line 3224a, and an appropriate seal (not shown) may be
10 provided where the SMA probe 3270 passes through the ground plane 3216 to hermetically seal the connection. It is understood that the other end of the SMA probes 3270, not connected to the antenna 3200, are connectable via a cable (not shown) to a signal generator or to a receiver, such as
15 a satellite signal decoder used with television signals.

In operation, the antenna 3200 may be used for transmitting and receiving linearly polarized (LP) EM beams. In the transmission of an EM beam, exemplified using a signal from the SMA probe 3270 with feed line to the
20 transmission line 3224a, the incoming signal travels as a traveling wave along the transmission line 3224a through the coupler 3400 to the opposing transmission line 3224a. The transmission line 3224a transports the EM power of the signal to the two branch transmission lines 3224b and,
25 subsequently, striplines 3224 of each branch transmission line 3224b with minimal reflection. The EM power is transmitted through the striplines 3224 to the array of patches 3220. The patches 3220 and portions of the striplines 3224 then induce a high-order standing wave for
30 proper radiation through the apertures 3250 of the antenna 3200.

In the transmission of an EM beam, exemplified using a signal from the SMA probe 3270 with feed line to the

transmission line 3226a, the incoming signal travels as a traveling wave along the transmission line 3226a through the coupler 3400 to the opposing transmission line 3226a. The transmission line 3226a transports the EM power of the signal to the two branch transmission lines 3226b and, subsequently, striplines 3226 of each branch transmission line 3226b with minimal reflection. The EM power is transmitted through the striplines 3226 to the array of patches 3220. The patches 3220 then induce a high-order standing wave for proper radiation through the apertures 3250 of the antenna 3200.

In the antenna 3200, the vertical modal excitation becomes orthogonal to that of the horizontal mode so that the cross-talk between the two input signals will be minimized. In other words, two orthogonal vertical and horizontal modes can be excited independently.

It is well known that antennas transmit and receive signals reciprocally. It can be appreciated, therefore, that operation of the antenna 3200 for transmitting signals is reciprocally identical to that of the antenna for receiving signals. Thus, for example, the antenna 3200 may be positioned in a residential home and directed for receiving from a geostationary, or equatorial, satellite a beam carrying a television signal within a predetermined frequency band or channel. The antenna 3200 is so directed by orienting the top surface 3212b toward the source of the beam so that it is generally perpendicular to the direction of the beam. Assuming that the elements of the antenna 3200 are correctly sized for receiving the beam, then the beam will pass through the apertures 3250 and induce a standing wave that will resonate within the dielectric layer 3212. A standing wave induced in the resonant cavity defined within the dielectric layer 3212 leaks electromagnetic power

through the striplines 3224 and 3226 and coupler 3400 to the appropriate SMA probe 3270 and delivered to a receiver, such as a decoder (not shown).

It is understood that the present invention can take many forms and embodiments. The embodiments described with respect to FIGURES 32 and 33 are intended to illustrate rather than to limit the invention. Accordingly, several variations may be made in the foregoing without departing from the spirit or the scope of the invention. For example, additional patches 3220 may be provided for narrowing a beam, or fewer patches 3220 may be utilized to reduce the physical space required for the antenna 3200 of the present invention. With proper modification near the feeding area, dual-mode operation with two orthogonal circular polarizations (CP) can be achieved.

FIGURES 34-35

Referring to FIGURE 34, the reference numeral 3400 designates, in general, a planar microstrip directional coupler embodying features of the present invention for coupling two EM energy sources to two EM energy destinations, so that EM energy may be communicated to/from the two sources from/to the two destinations without interference. As described above with respect to FIGURES 32-33, the coupler 3400 is preferably integrated into a microstrip antenna, such as the antenna 2900 and the antenna 3200. However, the coupler 3400 may also function as a standalone coupler, as shown in FIGURE 34, and, for the sake of simplicity, will be so described herein. Accordingly, the coupler 3400 includes a generally square, dielectric layer 3412. The dielectric layer 3412 has a width 3402 and length 3403 which may be equal or unequal.

Referring to FIGURE 35, the dielectric layer 3412 defines a bottom side 3412a to which a conductive ground

plane 3416 may optionally be bonded and a top side 3412b to which an array of conductive striplines are bonded for forming the directional coupler. The striplines include first striplines 3420 and 3422, between which EM energy is transferred, and second striplines 3424 and 3426, between which EM energy is transferred. The width of each stripline 4124 is preferably determined assuming a characteristic impedance Z_0 of about 50 to 200 ohms.

The striplines 3420, 3422, 3424, and 3426 are connected to a substantially rectangular bridge 3430 having, as viewed in FIGURE 34, two end portions 3432, top and bottom portions 3434, and a mid-section portion 3432. Preferably, the width of each end portion 3432 is determined assuming a characteristic impedance Z_0 of about 50 to 200 ohms, and the length 3432a of each end portion 3432 is about $0.25 \lambda_e$. Preferably, the width of each top and bottom portion 3434 is determined assuming a characteristic impedance $Z_0/(\text{square root of } 2)$ of about 35 to 141 ohms, and the length 3434a of each half of each end portion 3432 is about $0.25 \lambda_e$. Each top and bottom portion 3434 is further characterized by an end 3434b chamfered at an angle of about 45° , relative to the top and bottom portions. Preferably, the width of the mid-section portion 3436 is determined assuming a characteristic impedance $Z_0/2$ of about 25 to 100 ohms.

In operation, when coupler 3400 is used in conjunction with the antenna array of FIGURE 29, a line, such as the line 2928a depicted in FIG. 29, is connected to each first stripline 3420 and 3422, and a line, such as the line 2926a depicted by FIG. 29, is connected to each first stripline 3424 and 3426. EM energy on the stripline 2928a is passed from the stripline 3420 to the stripline 3422 (or from the stripline 3422 to the stripline 3420) with substantially negligible loss to the striplines 3424 and 3426. Similarly,

EM energy on the stripline 2926a passes from the stripline 3424 to the stripline 3426 (or from the stripline 3426 to the stripline 3424) with substantially negligible loss to the striplines 3420 and 3422.

5 It is understood, too, that any of the aforementioned antennas, configured for operation at one frequency, may be reconfigured for operation at substantially any other desired frequency without significantly altering characteristics, such as the radiation pattern and
10 efficiency of the antenna at the one frequency, by generally scaling each dimension of the antenna in direct proportion to the ratio of the desired frequency to the one frequency, provided that the dielectric constant of the dielectric layers remains substantially the same at the desired
15 frequency as at the one frequency.

 Although illustrative embodiments of the invention have been shown and described, a wide range of modification, change, and substitution is contemplated in the foregoing disclosure and, in some instances, some features of the
20 present invention may be employed without a corresponding use of the other features. Accordingly, it is appropriate that the appended claims be construed broadly and in a manner consistent with the scope of the invention, and with the understanding that the reference numerals provided
25 parenthetically are provided by way of example for the convenience and efficiency of examination, and are not to be construed as limiting any claim in any way.

What is claimed is:

1. An antenna **(100-3300)**, comprising:
a dielectric layer defining a first side and a second
5 side;
a conductive ground plane disposed on the first side of
the dielectric layer;
an array of spaced-apart, radiating patches disposed on
the second side of the dielectric layer; and
10 at least one stripline disposed on the second side of
the dielectric layer and electrically connected to at least
one corner of each patch.
2. The antenna **(100-3300)** of Claim 1, wherein the
15 patches and striplines are sized and positioned so that,
responsive to electromagnetic energy, a high-order standing
wave is induced in the antenna.
3. The antenna **(100-3300.)** of Claim 1 wherein the
20 antenna is planar.
4. The antenna **(100-1800)** of Claim 1, further
comprising at least one feeding means electrically connected
to the ground plane and at least one patch for feeding
25 electromagnetic energy to and/or extracting electromagnetic
energy from the antenna.
5. The antenna **(100-1800)** of Claim 1, further
comprising at least one feeding means having a first
conducting element electrically connected to the ground
30 plane and a second conducting element electrically connected
to at least one patch for feeding electromagnetic energy to
and/or extracting electromagnetic energy from the antenna.

6. The antenna **(100-1800)** of Claim 1, further comprising at least one of a probe, an SMA probe, an aperture-coupled line, and a microstripline electrically connected to the ground plane and at least one patch for
5 feeding electromagnetic energy to and/or extracting electromagnetic energy from the antenna.

7. The antenna **(100-1800)** of Claim 1, further comprising at least two feeding means, each of which
10 comprise one of a probe, an SMA probe, an aperture-coupled line, and a microstripline, each of which feeding means are orthogonally electrically connected to the ground plane and at least one patch for feeding electromagnetic energy to and/or extracting electromagnetic energy from the antenna.

15

8. The antenna **(100-1300)** of Claim 1, wherein the patches are arranged in a square array of equal rows and columns.

9. The antenna **(100)** of Claim 1, further comprising at least one tuning stub disposed on the second side of the dielectric layer and extending substantially perpendicularly from at least one of said at least one stripline.
20

10. The antenna **(400-800)** of Claim 1, wherein the
25 patches include at least four patches, and each patch includes first and second diametrically opposed corners and third and fourth diametrically opposed corners, and wherein the striplines are apportioned between a first group of parallel striplines and a second group of parallel
30 striplines, the striplines in the first group of striplines being oriented substantially perpendicular to the striplines in the second group of striplines, and wherein the first group of striplines electrically interconnects together at

least one of the first and second diametrically opposed corners of each of at least two of the at least four patches, and wherein the second group of striplines electrically interconnects together at least one of the
5 third and fourth diametrically opposed corners of each of at least two of the at least four patches.

11. The antenna **(400-600)** of Claim 1, wherein the patches include at least four patches, and each patch
10 includes first and second diametrically opposed corners and third and fourth diametrically opposed corners, and wherein the striplines are apportioned between a first group of parallel striplines and a second group of parallel striplines, the striplines in the first group of striplines
15 being oriented substantially perpendicular to the striplines in the second group of striplines, and wherein the first group of striplines electrically interconnects together at least one of the first and second diametrically opposed corners of each of at least two of the at least four
20 patches, and wherein the second group of striplines electrically interconnects together at least one of the third and fourth diametrically opposed corners of each of at least two of the at least four patches, and wherein the antenna further comprises one tuning stub extending
25 outwardly from each corner of a patch.

12. The antenna **(800)** of Claim 1, wherein the patches include at least four patches, and each patch includes first and second diametrically opposed corners and third and
30 fourth diametrically opposed corners, and wherein the striplines are apportioned between a first group of parallel striplines and a second group of parallel striplines, the striplines in the first group of striplines being oriented

substantially perpendicular to the striplines in the second group of striplines, and wherein the first group of striplines electrically interconnects together at least one of the first and second diametrically opposed corners of each of at least two of the at least four patches, and wherein the second group of striplines electrically interconnects together at least one of the third and fourth diametrically opposed corners of each of at least two of the at least four patches, and wherein the antenna further comprises one tuning stub extending outwardly from one corner of each of four patches toward a common point.

13. The antenna **(1000)** of Claim 1, wherein the patches include at least four patches, and each patch includes first and second diametrically opposed corners and third and fourth diametrically opposed corners, and wherein the striplines are apportioned between a first group of parallel striplines, a second group of parallel striplines, and a third group of striplines, the striplines in the first group of striplines being oriented substantially perpendicular to the striplines in the second group of striplines, the striplines in the third group of striplines being oriented at substantially 45° to the striplines in the first and second groups of striplines, and wherein the first group of striplines electrically interconnects together at least one of the first and second diametrically opposed corners of each of at least two of the at least four patches, and wherein the second group of striplines electrically interconnects together at least one of the third and fourth diametrically opposed corners of each of at least two of the at least four patches, and wherein, for at least one group of four patches, the antenna further comprises one tuning stub extending outwardly toward a common point from one

corner of each of the four patches constituting the at least one group of patches, and one stripline from the third group of stripline interconnects each tuning stub with each of two closest tuning stubs.

5

14. The antenna **(1300)** of Claim 1, wherein the patches include at least four patches, and each patch includes first and second diametrically opposed corners and third and fourth diametrically opposed corners, and wherein the
10 striplines are apportioned between a first group of parallel striplines, a second group of parallel striplines, and a third group of striplines, the striplines in the first group of striplines being oriented substantially perpendicular to the striplines in the second group of striplines, the
15 striplines in the third group of striplines being oriented at substantially 45° to the striplines in the first and second groups of striplines; and wherein the first group of striplines electrically interconnects together at least one of the first and second diametrically opposed corners of
20 each of at least two of the at least four patches, and wherein the second group of striplines electrically interconnects together at least one of the third and fourth diametrically opposed corners of each of at least two of the
at least four patches; and wherein, for at least one first
25 group of four patches, the antenna further comprises one short stub extending outwardly toward a common point from one corner of each of the four patches constituting the at least one group of patches, and one stripline from the third group of striplines interconnects each short stub with each
30 of two closest short stubs; and wherein, for at least one second group of four patches, the antenna further comprises one tuning stub extending outwardly toward a common point from one corner of each of the four patches constituting the

at least one group of patches, and one stripline from the third group of stripline interconnects each tuning stub with each of two closest tuning stubs, each tuning stub extending beyond the interconnection point of the respective
5 striplines and tuning stubs.

15. The antenna **(1600)** of Claim 1, wherein the antenna is a linear array antenna defining a first side and a second side, and wherein the antenna includes at least three
10 patches, each of which define first corners proximate to the first side, and second corners proximate to the second side; and wherein, between two adjacent patches, the striplines electrically interconnect a first corner of each patch with a second corner of the adjacent patch and those two
15 striplines are crisscrossed; and wherein the antenna further comprises at least one tuning stub extending outwardly from at least one corner of one patch, which corner is also connected to a stripline.

16. The antenna **(1900-3300.)** of Claim 1, further
20 comprising at least one feeding means electrically connected to the ground plane and through at least one transmission line and at least one stripline to at least one patch for feeding electromagnetic energy to and/or extracting electromagnetic energy from the antenna.

25

17. The antenna **(1900-3300.)** of Claim 1, further comprising at least one feeding means having a first conducting element electrically connected to the ground plane and a second conducting element electrically connected
30 through at least one transmission line and at least one stripline to at least one patch for feeding electromagnetic energy to and/or extracting electromagnetic energy from the antenna.

18. The antenna **(1900-3300.)** of Claim 1, further comprising at least one of a probe, an SMA probe, an aperture-coupled line, and a microstripline electrically
5 connected to the ground plane and through at least one transmission line and at least one stripline to at least one patch for feeding electromagnetic energy to and/or extracting electromagnetic energy from the antenna.

10 19. The antenna **(2300, 2900, 3200)** of Claim 1, further comprising at least two feeding means, each of which comprise one of a probe, an SMA probe, an aperture-coupled line, and a microstripline, each of which feeding means are orthogonally electrically connected to the ground plane and
15 through at least one transmission line and at least one stripline to at least one patch for feeding electromagnetic energy to and/or extracting electromagnetic energy from the antenna.

20 20. The antenna **(1900, 2100, 2500)** of Claim 1, further comprising at least one feeding means electrically connected to the ground plane and through a transmission line connected to a plurality of striplines connected to at least one corner of at least one patch for feeding electromagnetic energy to and/or extracting electromagnetic energy from the
25 antenna.

21. The antenna **(1900, 2500)** of Claim 1, further comprising at least one feeding means electrically connected to the ground plane and through a transmission line connected to a plurality of striplines connected to at least one corner of at least one patch for feeding electromagnetic energy to and/or extracting electromagnetic energy from the antenna, and wherein the transmission line is centrally disposed on the second side of the dielectric layer.

22. The antenna **(2100)** of Claim 1, further comprising at least one feeding means electrically connected to the ground plane and through a transmission line connected to a plurality of striplines connected to at least one corner of at least one patch for feeding electromagnetic energy to and/or extracting electromagnetic energy from the antenna, and wherein the transmission line is disposed on the second side of the dielectric layer outside the array of patches.

23. The antenna **(2300, 2900)** of Claim 1, further comprising:

a first feeding means electrically connected to the ground plane and through a first transmission line connected to a plurality of substantially parallel first striplines to at least one corner of at least one patch for feeding electromagnetic energy to and/or extracting electromagnetic energy from the antenna, wherein the first transmission line is substantially perpendicular to the first striplines and positioned outside the array of patches; and

a second feeding means electrically connected to the ground plane and through a second transmission line connected to a plurality of substantially parallel second striplines to at least one corner of at least one patch for feeding electromagnetic energy to and/or extracting

electromagnetic energy from the antenna, wherein the second transmission line is substantially perpendicular to the second striplines and positioned outside the array of patches, and wherein the first striplines are substantially perpendicular to the second striplines.

24. The antenna **(2700)** of Claim 1, further comprising:
at least one feeding means electrically connected to the ground plane and through a transmission line connected to a plurality of substantially parallel first striplines connected to at least one first corner of each of at least one patch for feeding electromagnetic energy to and/or extracting electromagnetic energy from the antenna, and wherein the transmission line is generally centrally disposed on the second side of the dielectric layer within the array of patches; and

a plurality of substantially parallel second striplines connected to at least one second corner of each of at least one patch, wherein the first striplines are substantially perpendicular to the second striplines, and the first corners are diametrically opposed to the second corners.

25. The antenna **(2900)** of Claim 1, further comprising:
a first feeding means electrically connected to the ground plane and through a first transmission line connected to a plurality of substantially parallel first striplines to at least one corner of at least one patch for feeding electromagnetic energy to and/or extracting electromagnetic energy from the antenna, wherein the first transmission line is substantially perpendicular to the first striplines and generally centrally disposed on the second side of the dielectric layer within the array of patches; and

a second feeding means electrically connected to the ground plane and through a second transmission line connected to a plurality of substantially parallel second striplines to at least one corner of at least one patch for feeding electromagnetic energy to and/or extracting electromagnetic energy from the antenna, wherein the second transmission line is substantially perpendicular to the second striplines and generally centrally disposed on the second side of the dielectric layer within the array of patches, wherein the first striplines are substantially perpendicular to the second striplines, and wherein the second transmission line further comprises a bridge configured generally at the intersection of the first and second transmission lines, the bridge comprising vias extending from the second transmission line on each side of the first transmission line through apertures formed in the dielectric, the ground plane, and a second dielectric to a microstrip disposed on the second dielectric for the transmission of electromagnetic energy across the second transmission line.

26. The antenna (3200) of Claim 1, further comprising:

a first feeding means electrically connected to the ground plane and through first and second portions of a first transmission line connected to a plurality of substantially parallel first striplines to at least one corner of at least one patch for feeding electromagnetic energy to and/or extracting electromagnetic energy from the antenna, wherein the first transmission line is substantially perpendicular to the first striplines and generally centrally disposed on the second side of the dielectric layer within the array of patches;

a second feeding means electrically connected to the ground plane and through first and second portions of a second transmission line connected to a plurality of substantially parallel second striplines to at least one corner of at least one patch for feeding electromagnetic energy to and/or extracting electromagnetic energy from the antenna, wherein the second transmission line is substantially perpendicular to the second striplines and generally centrally disposed on the second side of the dielectric layer within the array of patches, wherein the first striplines are substantially perpendicular to the second striplines; and

a directional coupler configured for providing electrical continuity between the first and second portions of the first transmission line, and for providing electrical continuity between the first and second portions of the second transmission line, such that transmission of electromagnetic energy between the first and second transmission lines is substantially inhibited, the coupler comprising:

a first microstrip longitudinal section defining a first end connected to the first portion of the first

transmission line, a second end connected to the first portion of the second transmission line;

a second microstrip longitudinal section defining a first end connected to the second portion of the first transmission line, a second end connected to the second portion of the second transmission line;

a first microstrip end connection section connected between the first end of the first longitudinal section and the first end of the second longitudinal section;

a second microstrip end connection section connected between the second end of the first longitudinal section and the second end of the second longitudinal section; and

an intermediate microstrip connection section connected between the mid-section of the first longitudinal section and the mid-section of the second longitudinal section, wherein the first, second, and intermediate connection sections are sized so that the centerlines of the first and second longitudinal sections are spaced apart by about a quarter-wavelength, and so that the centerlines of the first and intermediate connection sections are spaced apart by about a quarter-wavelength, and so that the centerlines of the second and intermediate connection sections are spaced apart by about a quarter-wavelength, and wherein the widths of the first and second longitudinal sections and the intermediate sections are determined assuming an impedance of X , and the widths of the first and second end connection sections are determined assuming an impedance of about $2X$, wherein X is about 25 to 100 ohms.

27. A planar microstrip directional coupler configured for providing electrical continuity between first and second portions of a first transmission line, and for providing electrical continuity between first and second portions of a second transmission line, such that transmission of electromagnetic energy between the first and second transmission lines is substantially inhibited, the coupler comprising:

10 a first microstrip longitudinal section defining a first end connected to the first portion of the first transmission line, a second end connected to the first portion of the second transmission line;

15 a second microstrip longitudinal section defining a first end connected to the second portion of the first transmission line, a second end connected to the second portion of the second transmission line;

a first microstrip end connection section connected between the first end of the first longitudinal section and the first end of the second longitudinal section;

20 a second microstrip end connection section connected between the second end of the first longitudinal section and the second end of the second longitudinal section; and

25 an intermediate microstrip connection section connected between the midpoint of the first longitudinal section and the midpoint of the second longitudinal section, wherein the first, second, and intermediate connection sections are sized so that the centerlines of the first and second longitudinal sections are spaced apart by about a quarter-wavelength, and so that the centerlines of the first and
30 intermediate connection sections are spaced apart by about a quarter-wavelength, and so that the centerlines of the second and intermediate connection sections are spaced apart by about a quarter-wavelength, and wherein the widths of the

first and second longitudinal sections and the intermediate sections are determined assuming an impedance of X , and the widths of the first and second end connection sections are determined assuming an impedance of about $2X$, wherein X is about 25 to 100 ohms.

28. The coupler of Claim 27, wherein each of the first and second ends of the first and second longitudinal sections are chamfered at an angle of about 45° .

10

29. A microstrip array antenna, comprising:

a single layer of dielectric material;

a ground plane contiguous a first side of said dielectric material;

15 a plurality of patches contiguous a second side of said dielectric material opposite said first side;

a feed terminal; and

20 a plurality of stripline conductors whereby said feed terminal is physically connected to each of said plurality of patches, a cavity formed between the patches, the striplines and the ground plane being configured such that standing waves are formed in the cavity whereby some nodes of the standing wave exist at each of said stripline conductors.

25

30. A method of designing a microstrip array antenna, comprising the steps of:

attaching a ground plane to a first side of a planar dielectric; and

30 configuring radiating patches, a feed terminal and associated conductive material that connects the feed terminal to each of the radiating patches, on a second side of said planar dielectric, opposite said first side, to

insure that a standing wave having a plurality of nodes is formed in a cavity between the patches, the associated conductive material and the ground plane wherein at least some nodes of the standing wave are coincident with the position of said associated conductive material.

31. The method of Claim 30, wherein the associated conductive material is configured as striplines.

32. A method of designing a microstrip array antenna, comprising the steps of:

attaching a ground plane to a first side of a planar dielectric; and

configuring radiating patches, a feed terminal and associated conductive material that connect the feed terminal to each of the radiating patches, on a second side of said planar dielectric, opposite said first side, to insure that a standing wave having a plurality of nodes is formed in a cavity between the patches, the associated conductive material and the ground plane to provide a predetermined distribution of electromagnetic power over the radiating patches.

33. The method of Claim 32, wherein the associated conductive material is configured as striplines and the predetermined distribution is substantially uniform.

34. The method of Claim 32, wherein the associated conductive material is configured as striplines and the predetermined distribution is tapered to minimize sidelobe energy distribution.

35. A planar microstrip array antenna, comprising:

a single layer of dielectric material;

a ground plane contiguous a first side of said dielectric material;

5 a plurality of patches contiguous a second side of said dielectric material opposite said first side wherein all of the patches used in an operational mode are of the same physical size;

a feed terminal; and

10 a plurality of stripline conductors directly interconnecting said feed terminal to each of said plurality of patches.

36. A method of distributing EM (electromagnetic) energy between first and second energy sources and their
15 respective energy sinks where the first and second energy sources are physically connected to their respective energy sinks via first and second sets of intersecting conductors in the same plane but having different angular orientations, comprising the steps of:

20 providing a resonant cavity contiguous the plane of said intersecting conductors; and

generating first and second standing waves of first and second angular orientations from said first and second EM sources whereby nodes of said first and second standing
25 waves occur at the intersections of at least some of said first and second sets of intersecting conductors such that excitations of the two modes are independent with each other.

30 37. The method of Claim 36, wherein the intersecting conductors are striplines.

38. An antenna, comprising:

a ground plane;

a surface area including radiating array elements, a signal source terminal and associated conductive material interconnecting said radiating patches and said signal source terminal; and

a resonant signal cavity between said ground plane and said surface area configured to create, upon the application of EM (electromagnetic) power to said antenna, a standing wave the nodes of which exist at both the radiating array element and the associated conductive material.

39. The apparatus of Claim 38, wherein the radiating array elements are patches of conductive material and the associated conductive material comprises stripline elements.

15

40. A microstrip planar array antenna, comprising:

a plurality of radiating array elements in a planar array;

a feed terminal in said planar array;

a plurality of associated conductive material elements, in said planar array, whereby said feed terminal is physically connected to each of said plurality of substantially identical size patches; and

a resonant cavity contiguous said planar array configured such that standing waves formed in the cavity have nodes at the cross points of two vertical and horizontal striplines.

41. The apparatus of Claim 40, wherein:

the radiating array elements are radiating patches and are substantially identical size for maximum directivity; and

the associated conductive material elements are striplines.

42. A microstrip single planar array antenna that can
5 be used, without modification, for circular and linear polarized beam signals, comprising:

a plurality of radiating patches in a planar array;

first and second feed terminals in said planar array;

10 first and second sets of stripline conductors, in said planar array, whereby each of said feed terminals is physically connected to each of said plurality of substantially identical size patches with said first and second sets of stripline conductors being oriented in different angular directions such that they form a plurality
15 of criss-cross intersections; and

a resonant cavity contiguous said planar array configured such that standing waves formed in the cavity have nodes coincident with a majority of said stripline criss-cross intersections and said radiating patches.

20

43. The apparatus of Claim 42, wherein the radiating patches are substantially identical size for maximum directivity.

25 44. The antenna of either Claims 41 or 43, wherein the patches are square.

45. A method of increasing the transmission efficiency of a microstrip array antenna including radiating patches
30 and a signal source terminal in a given plane juxtaposed a resonant cavity, comprising the steps of:

electrically connecting the source terminal to each of the radiating patches with a plurality of conductive strips; and

5 configuring the antenna elements whereby a standing wave occurring in said resonant cavity has nodes at the cross points of a majority of said conductive strips in a modal excitation manner whereby the cross-talk levels are minimized.

10 46. An antenna (100-3300), comprising:

a dielectric layer defining a first side and a second side;

a conductive ground plane disposed on the first side of the dielectric layer;

15 an array of spaced-apart, radiating patches disposed on the second side of the dielectric layer; and

at least one interconnecting element disposed on the second side of the dielectric layer and electrically interconnecting at least one corner of each patch of said array of patches.

20

47. The antenna of Claim 46, wherein the at least one interconnecting element and said patches defines one surface of a leaky cavity operationally including a standing wave.

25 48. The antenna of Claim 46, wherein the at least one interconnecting element operates to guide the power flow of standing waves formed in cavity the boundaries of which are delineated by said dielectric layer.

30 49. The antenna of Claim 46, wherein the at least one interconnecting element operates in conjunction with said patches to define antenna bandwidth.

50. The antenna of Claim 46, wherein the at least one interconnecting element operates in conjunction with said patches to define a standing wave resonant frequency of a cavity formed within the boundaries of the dielectric layer.

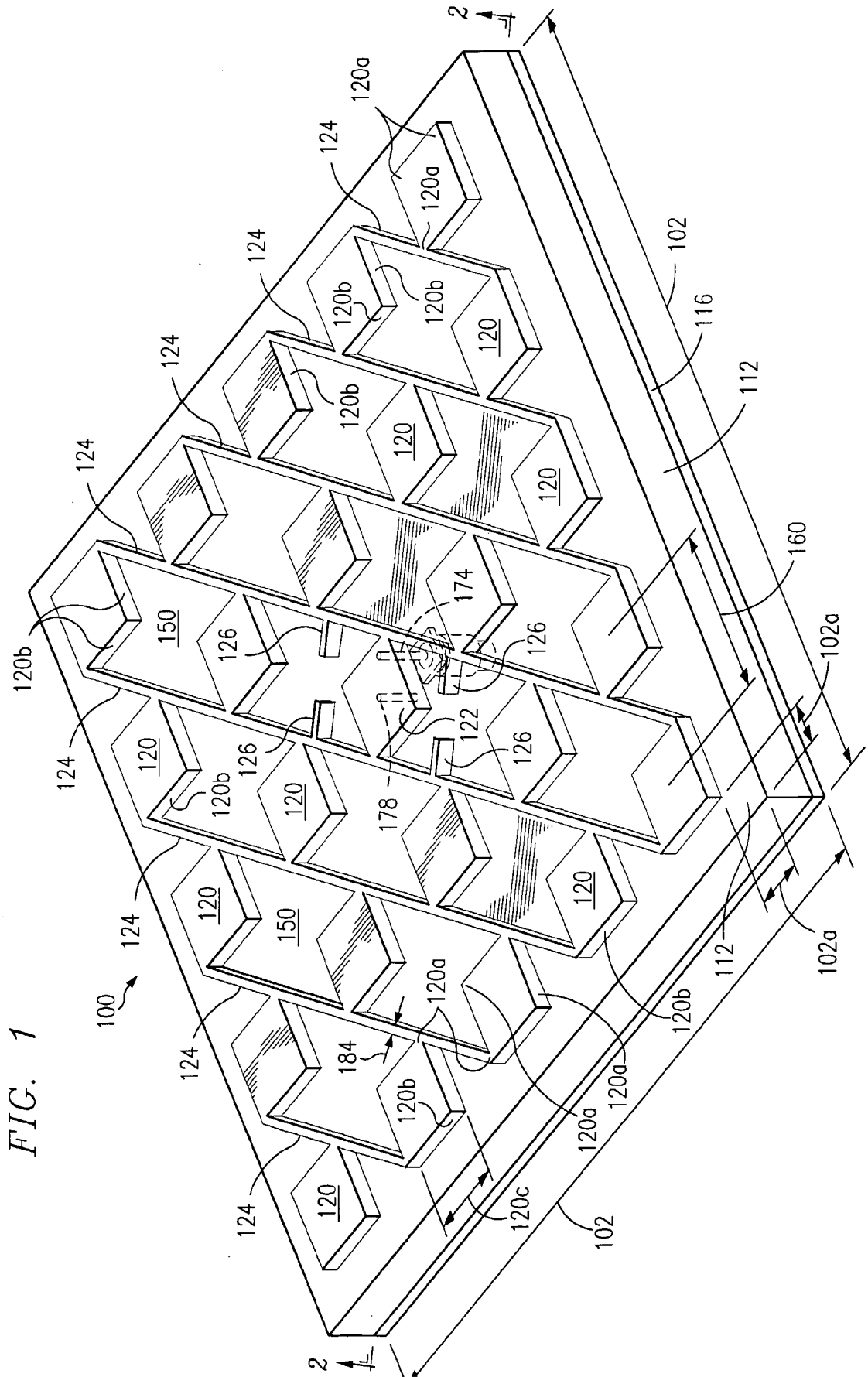

FIG. 1

FIG. 2

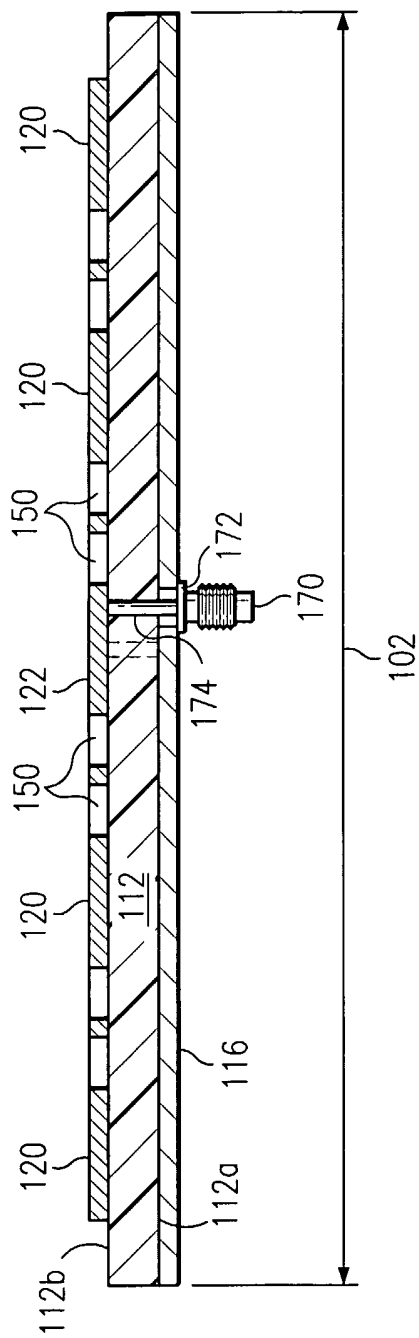

FIG. 4

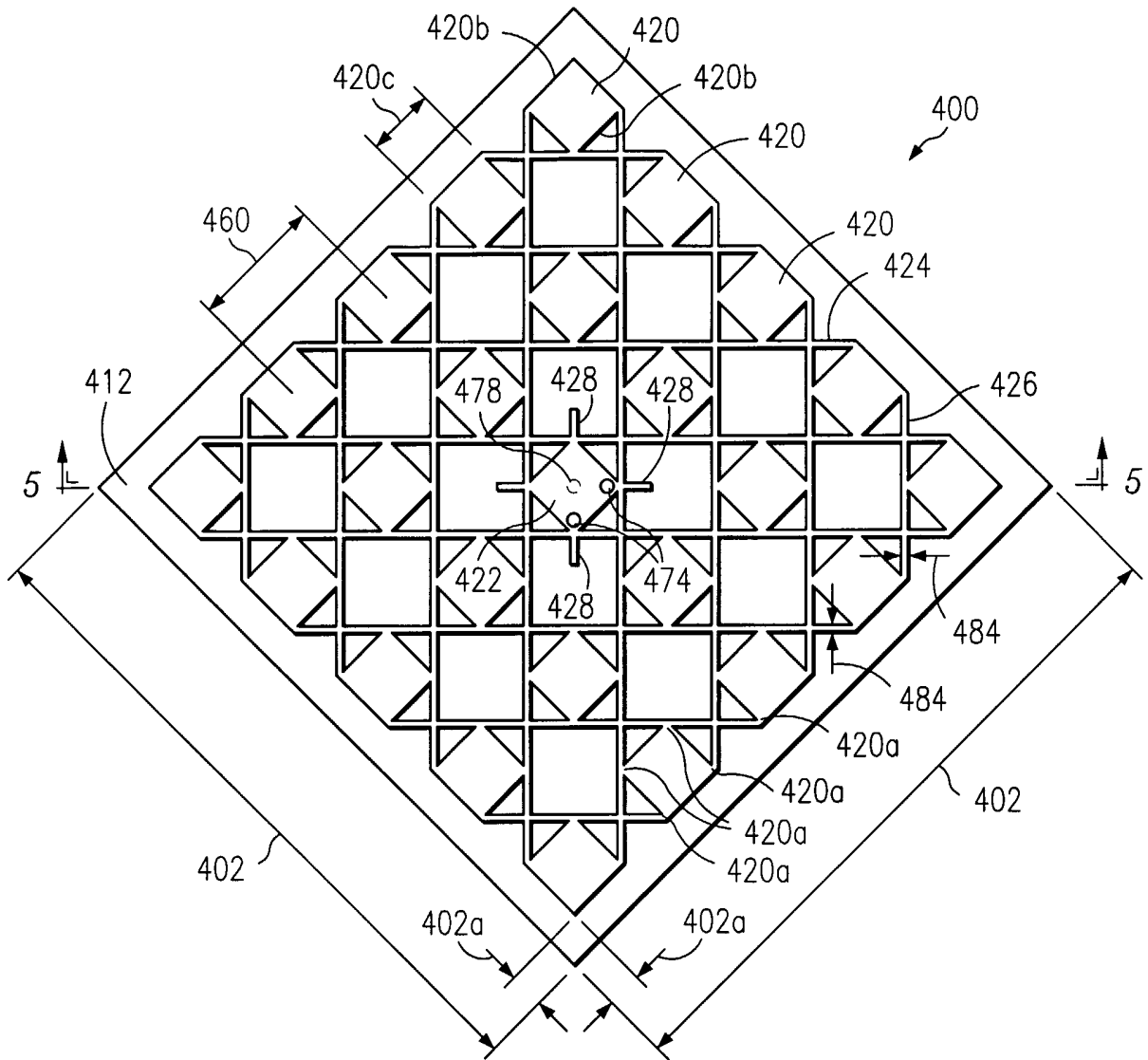

FIG. 5

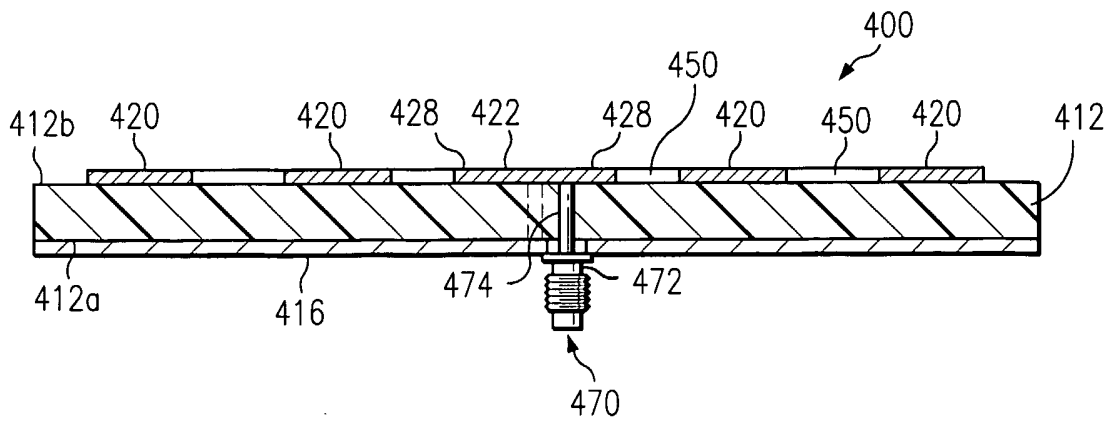

FIG. 8

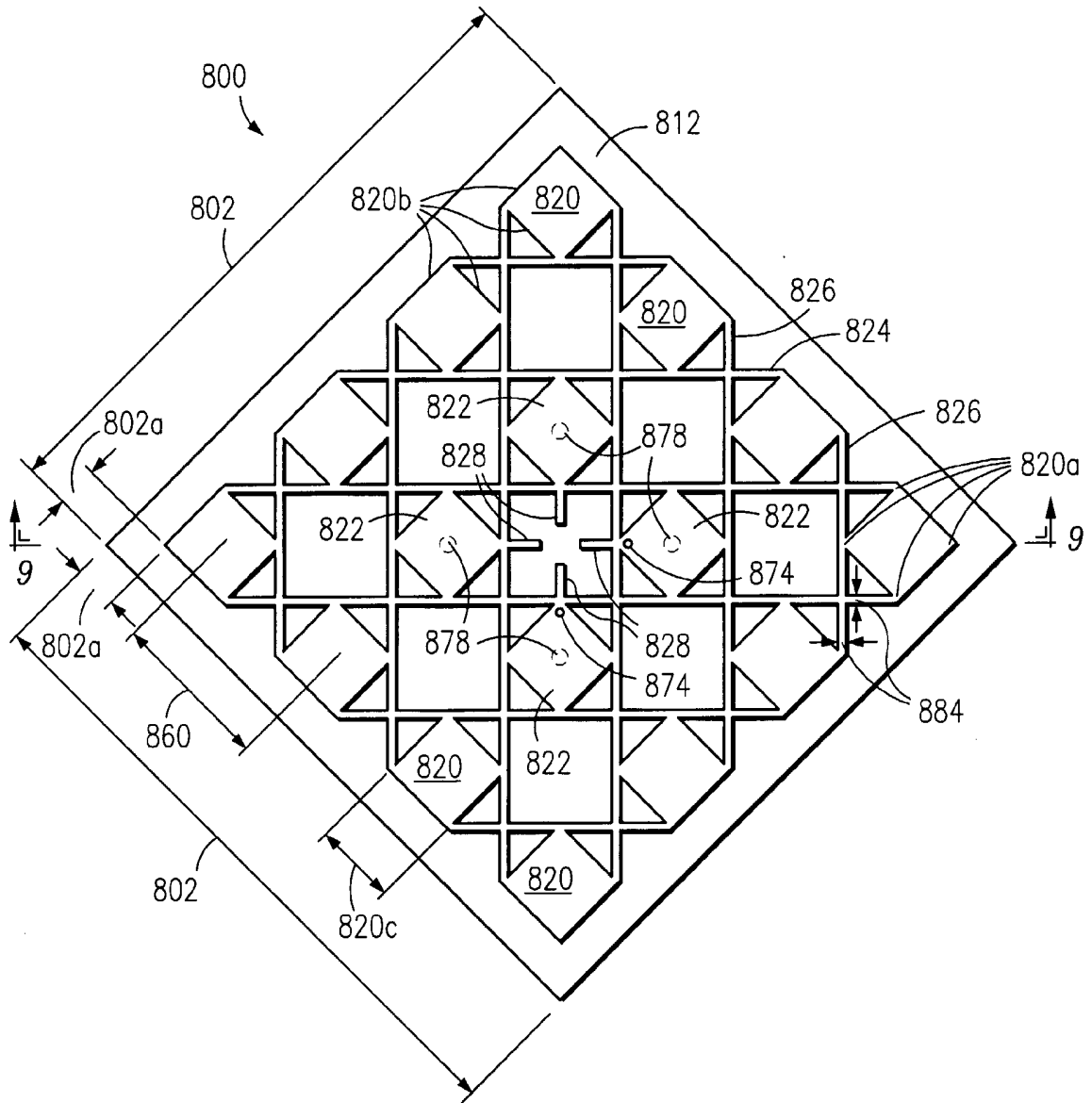

FIG. 9

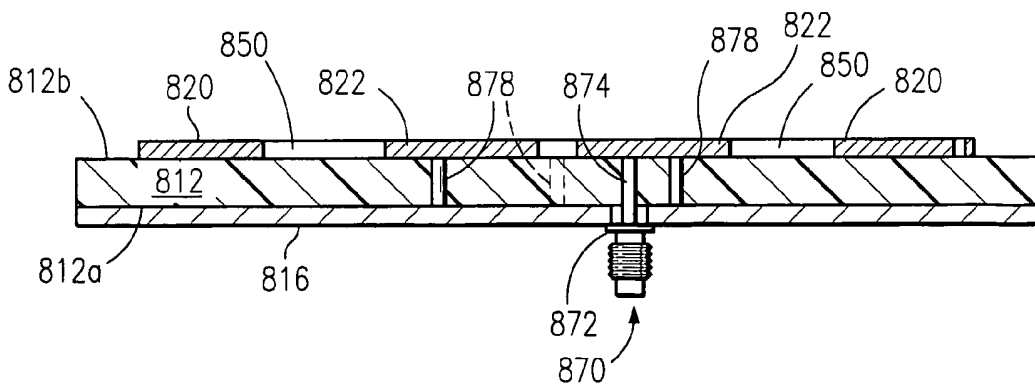

FIG. 12

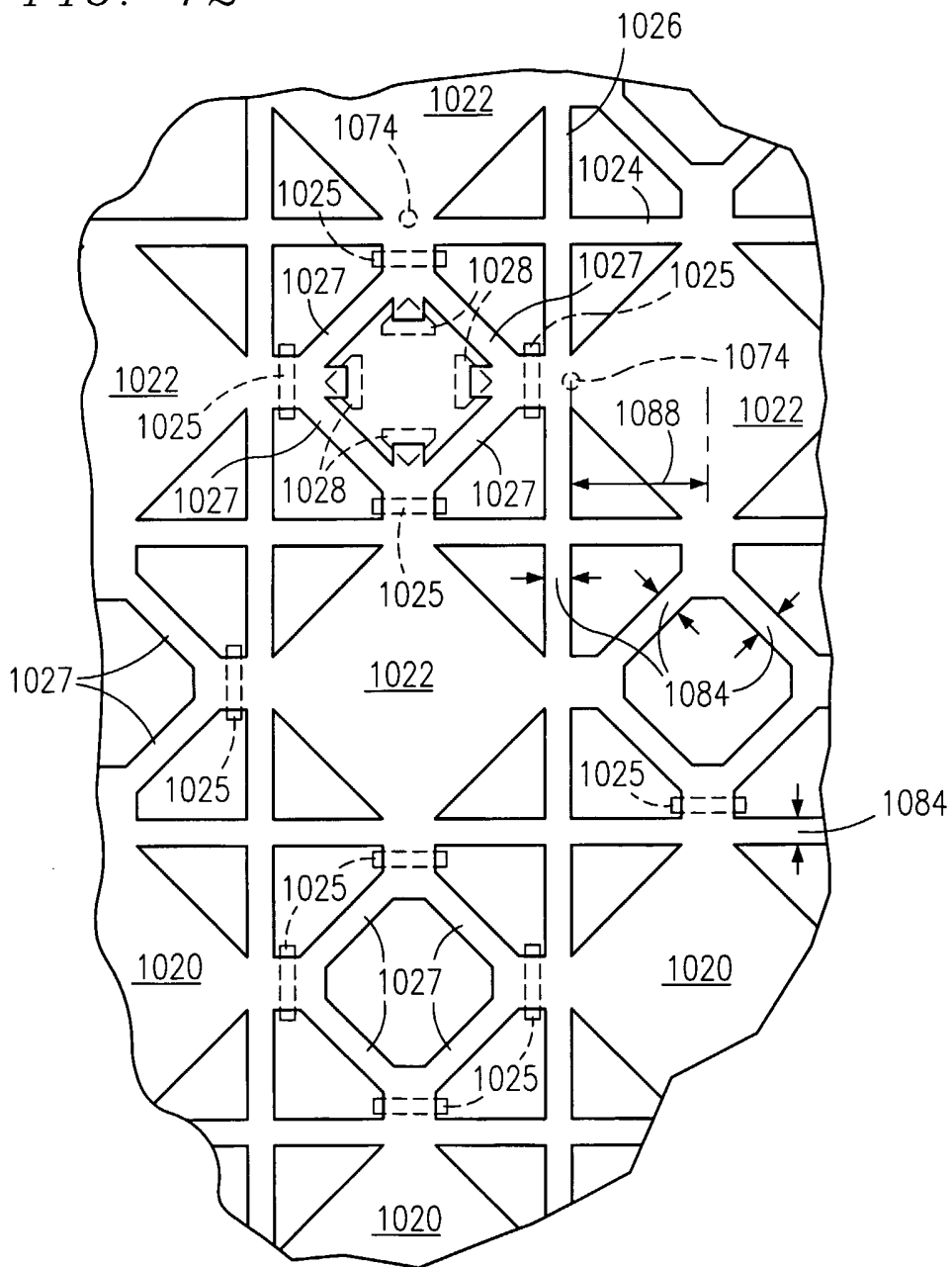

FIG. 13

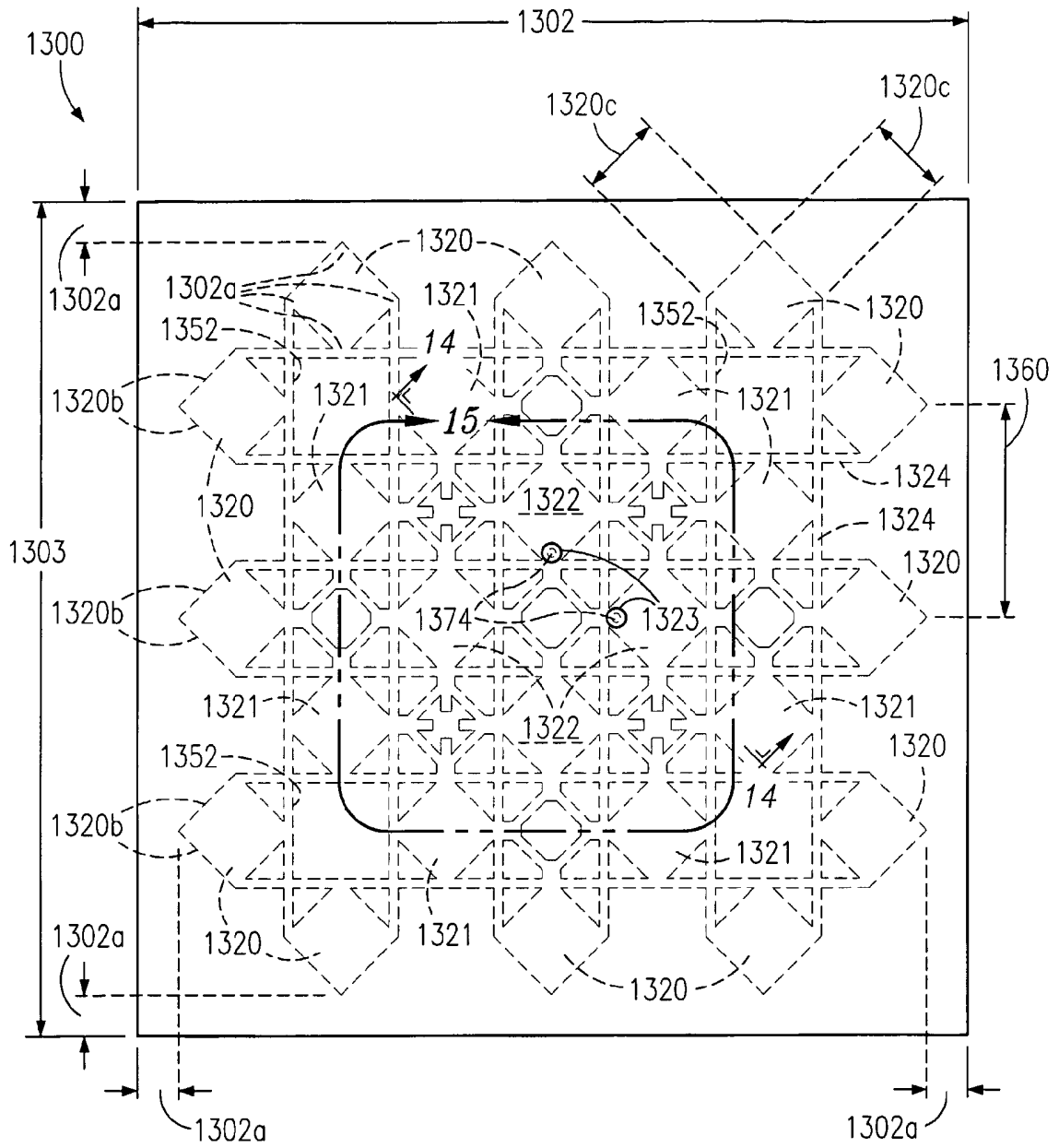

FIG. 14

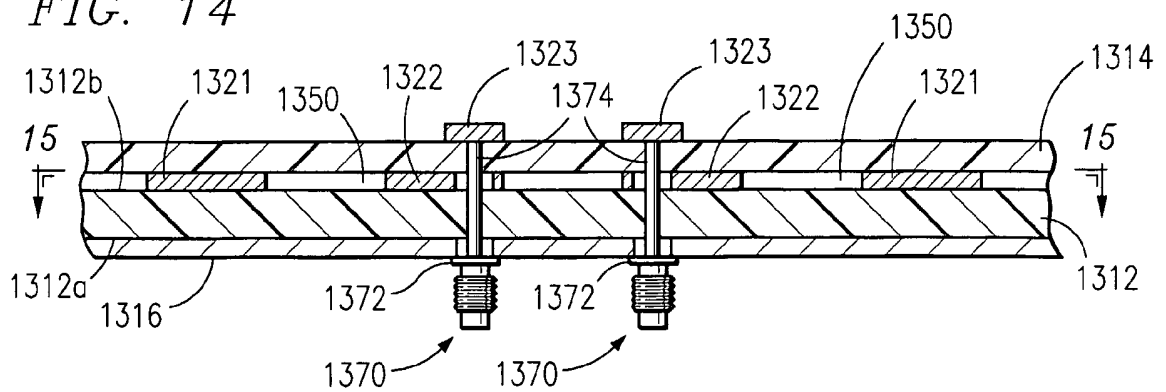

FIG. 15

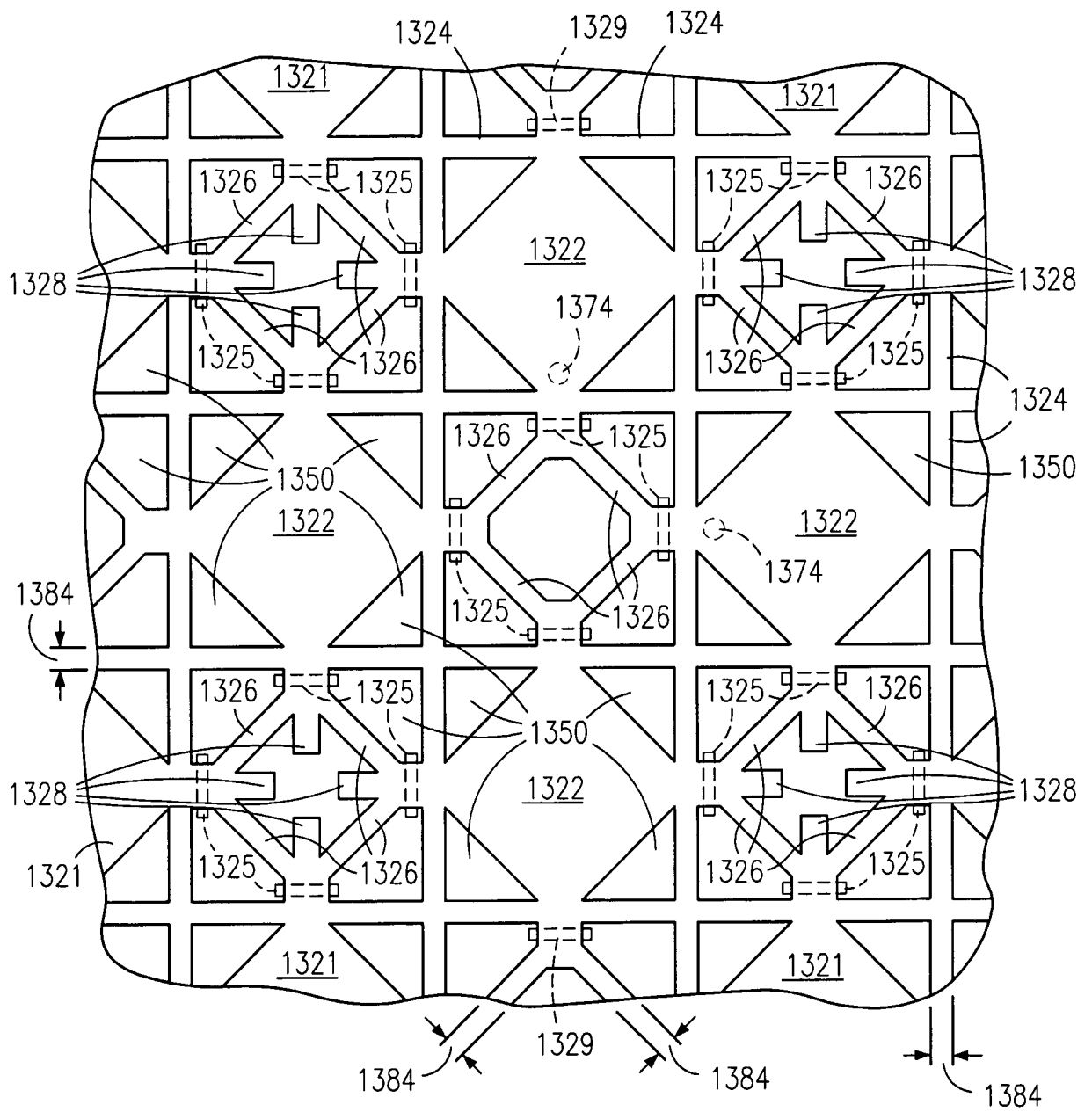

FIG. 16

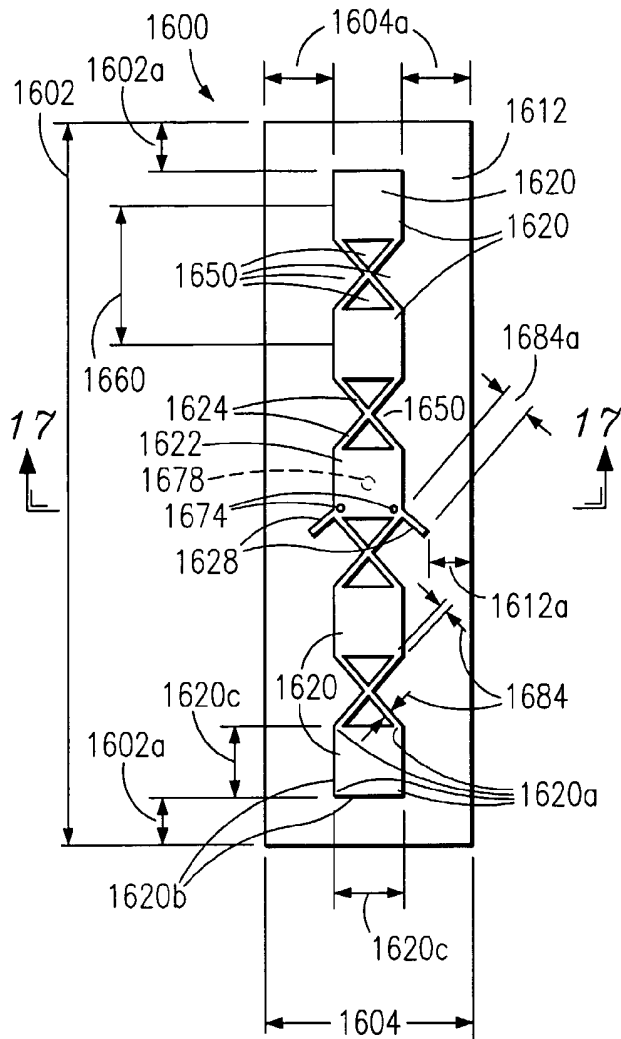

FIG. 18

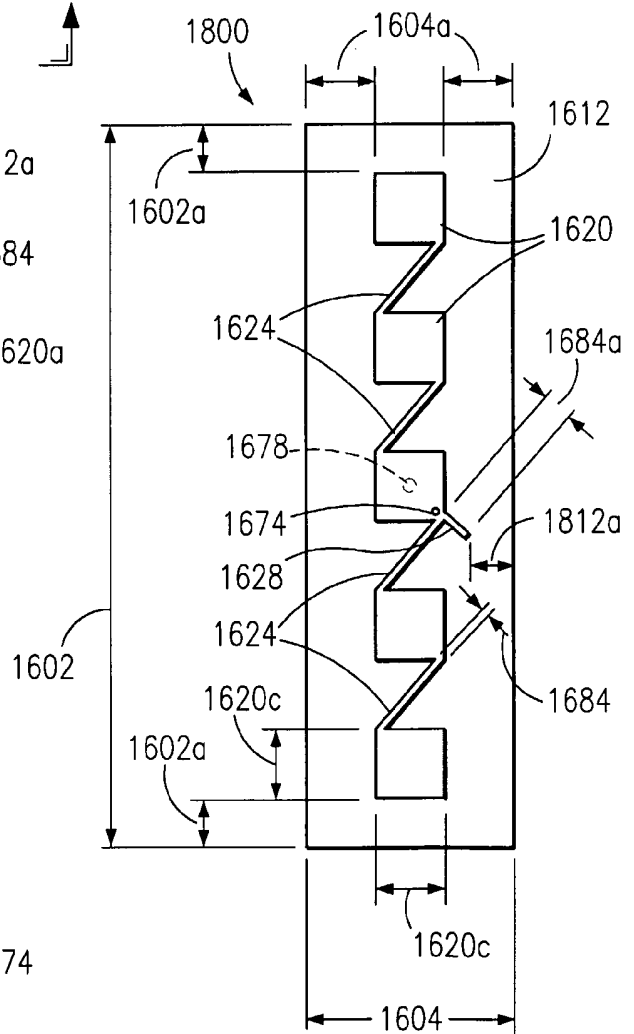

FIG. 17

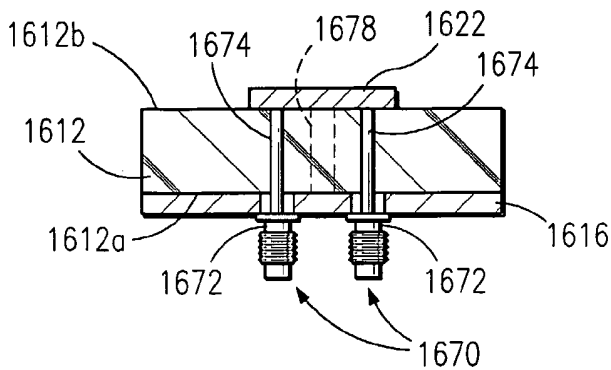

FIG. 19

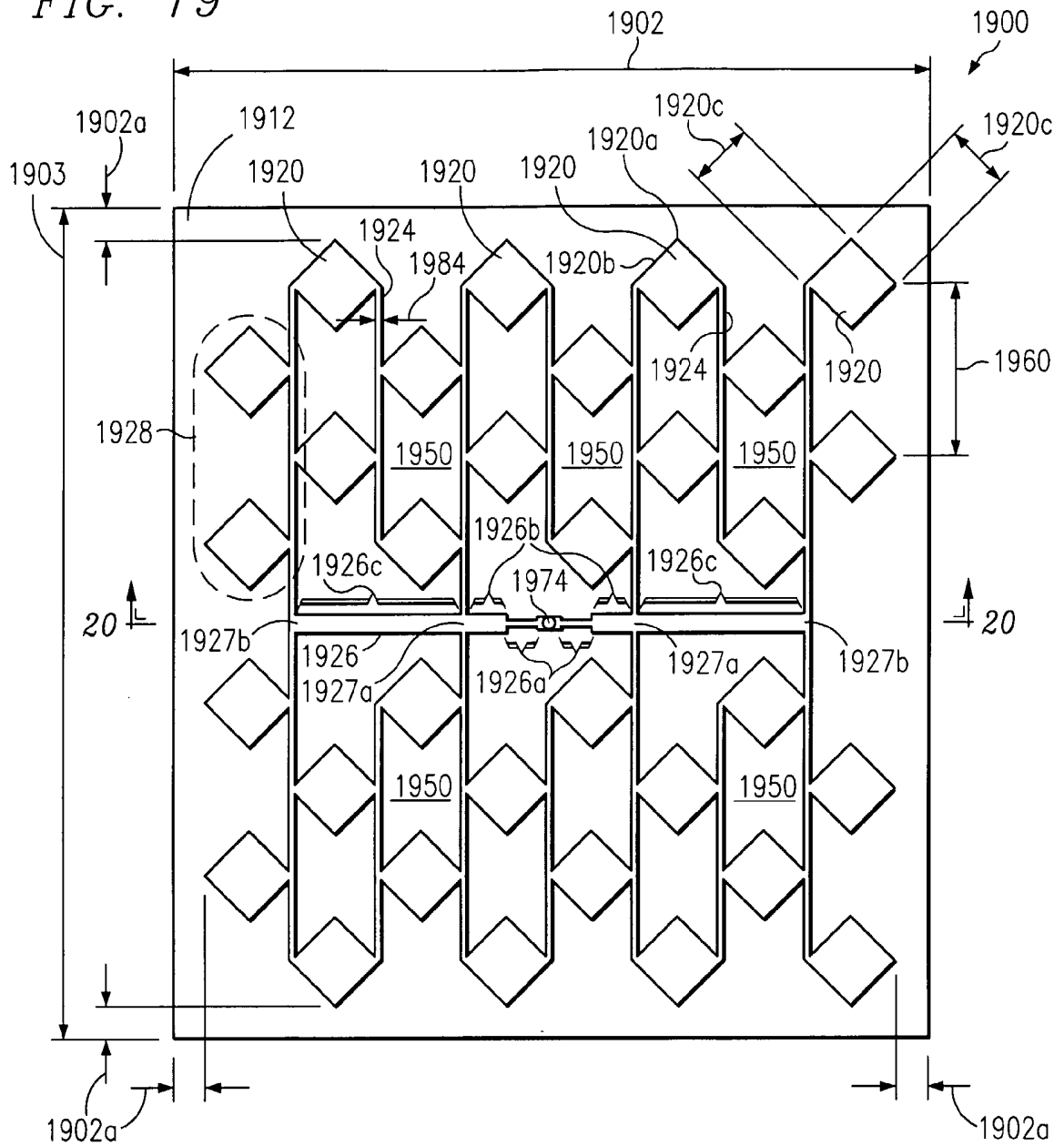

FIG. 20

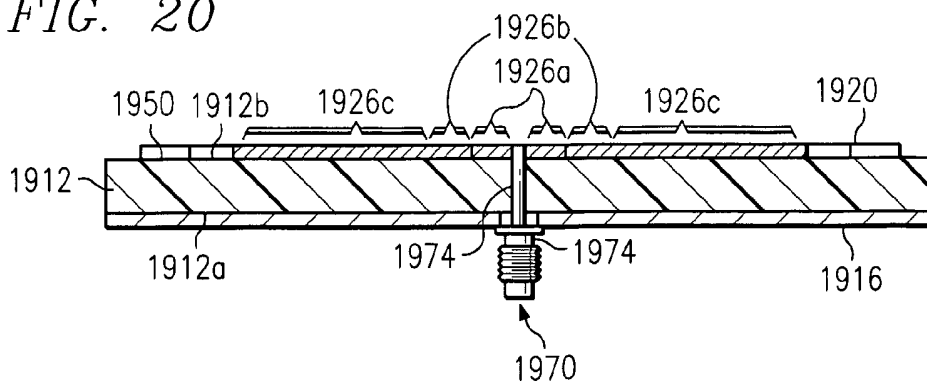

FIG. 21

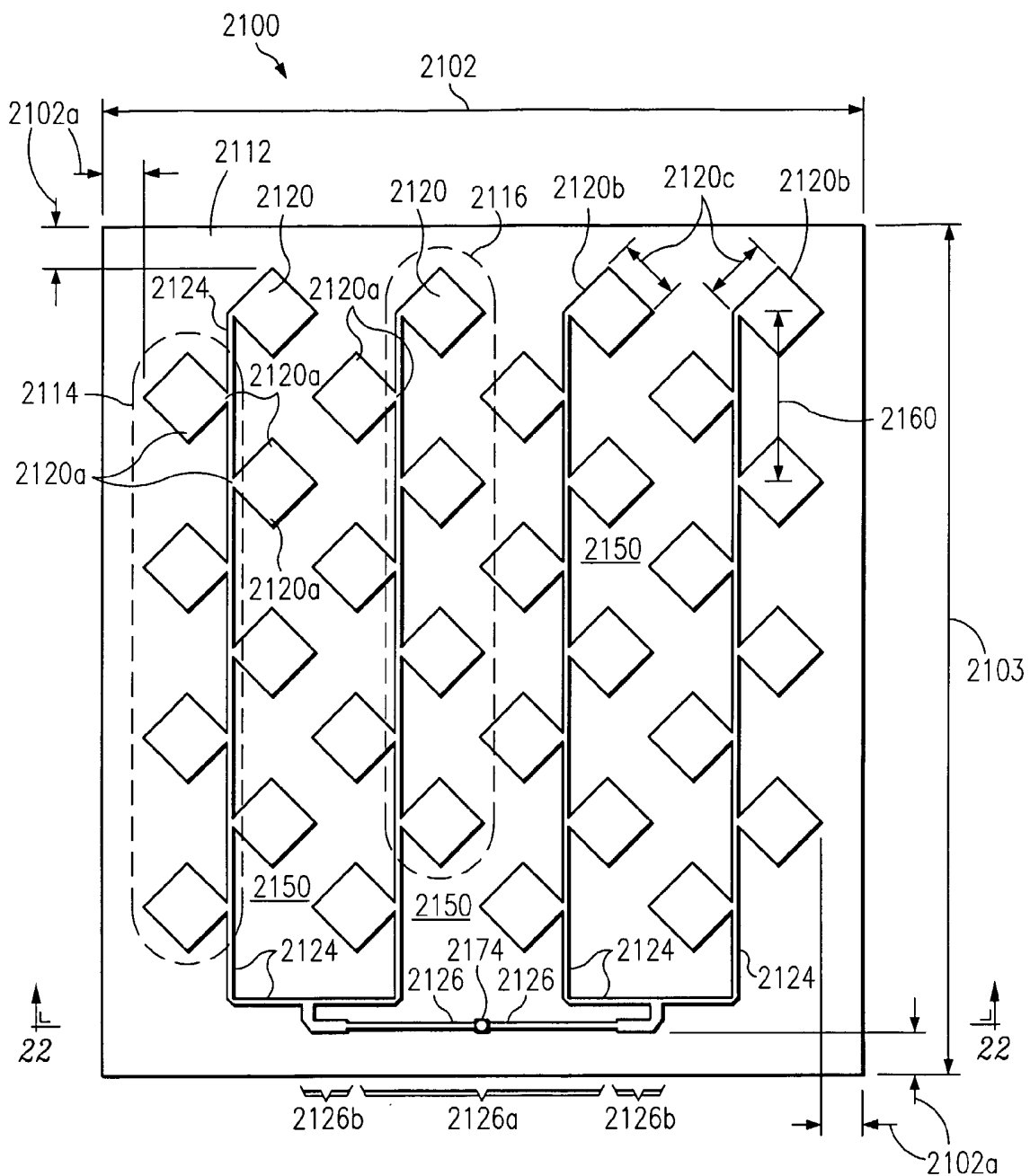
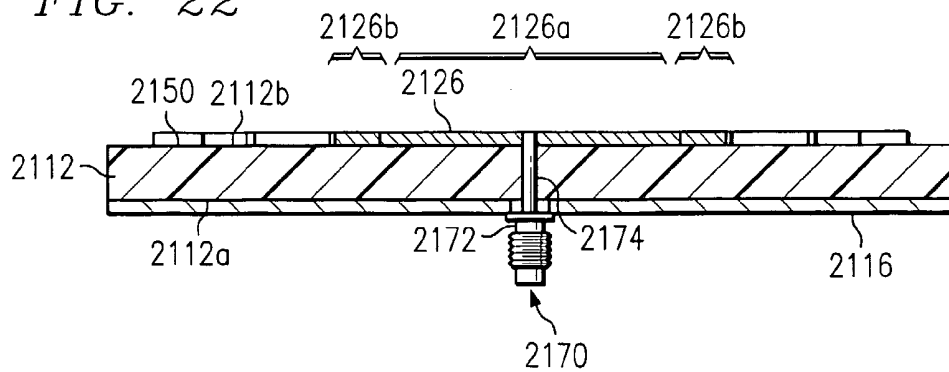
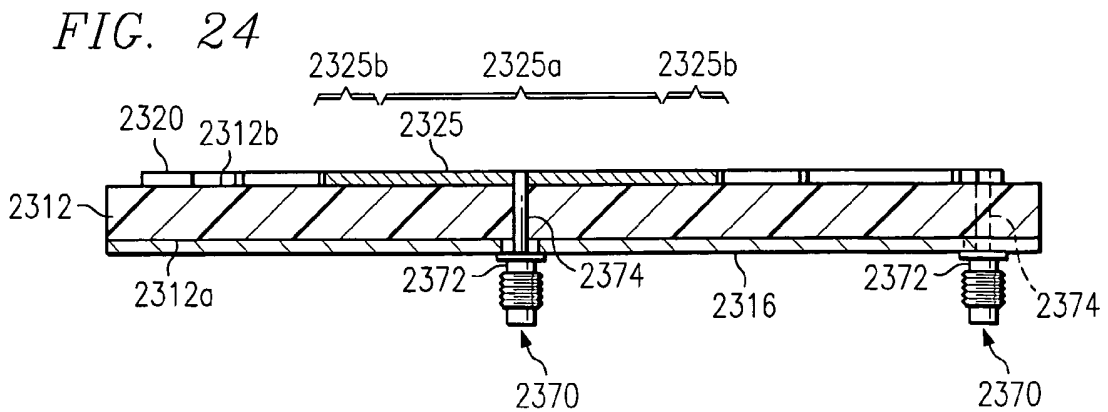
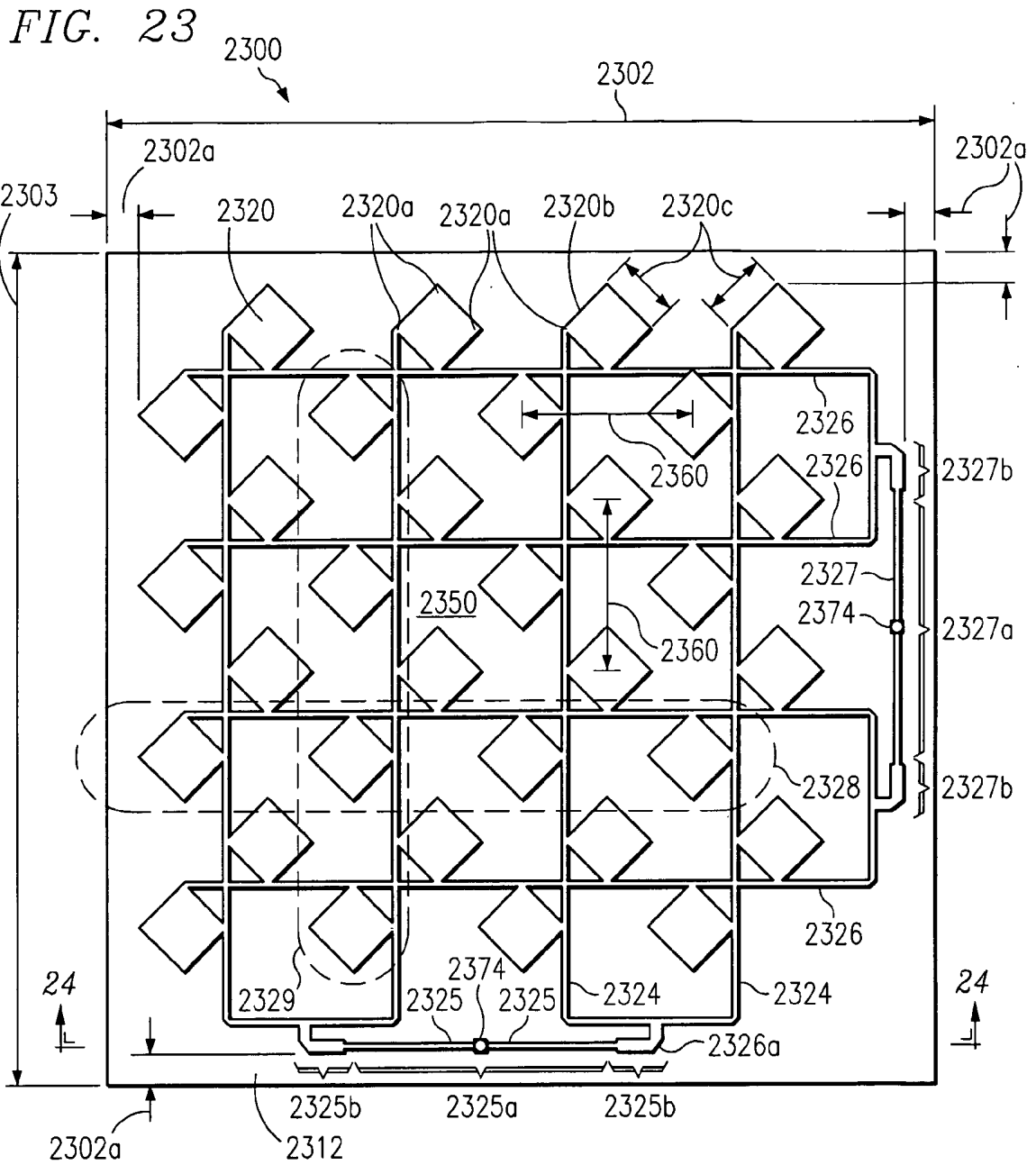

FIG. 22





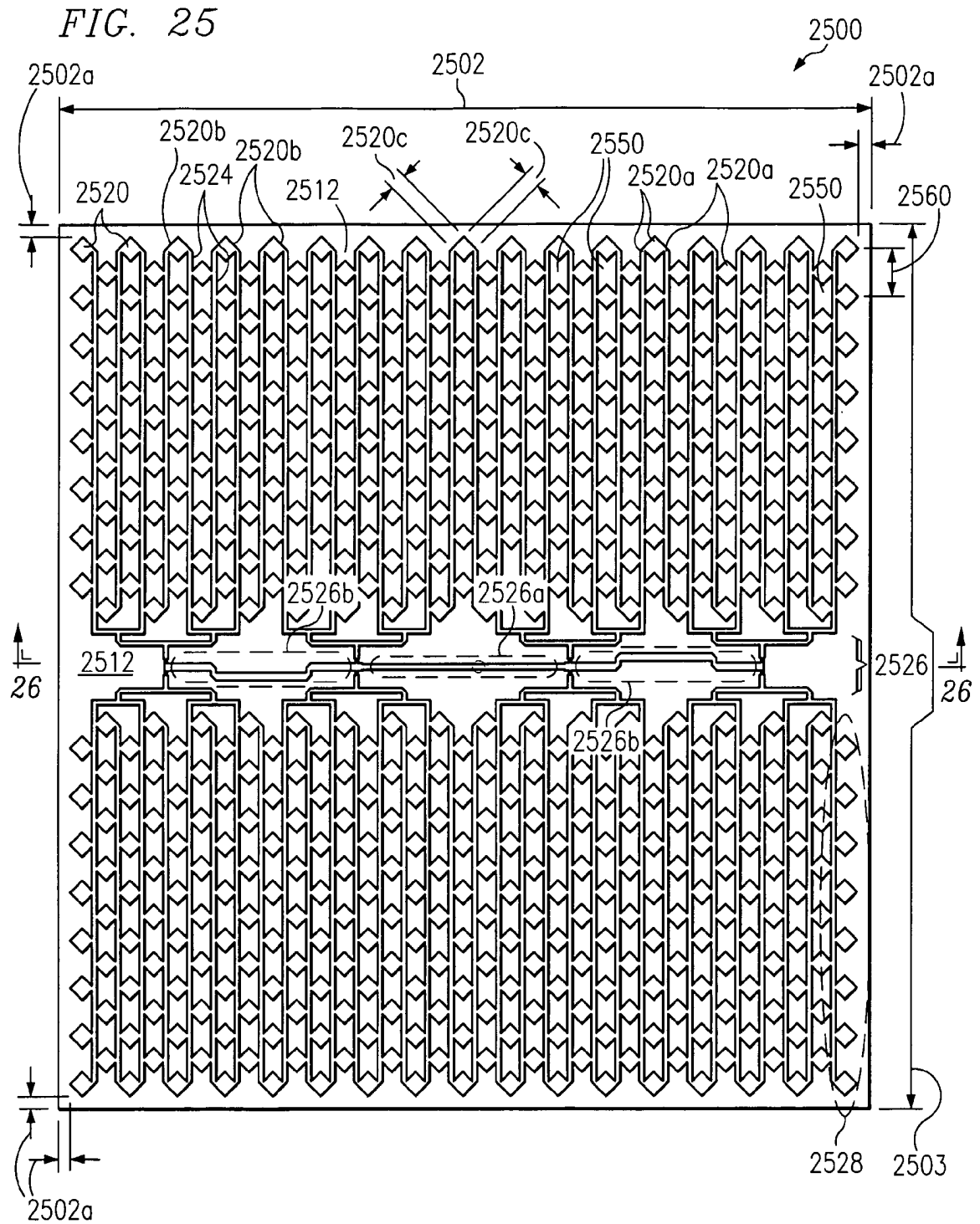

FIG. 26

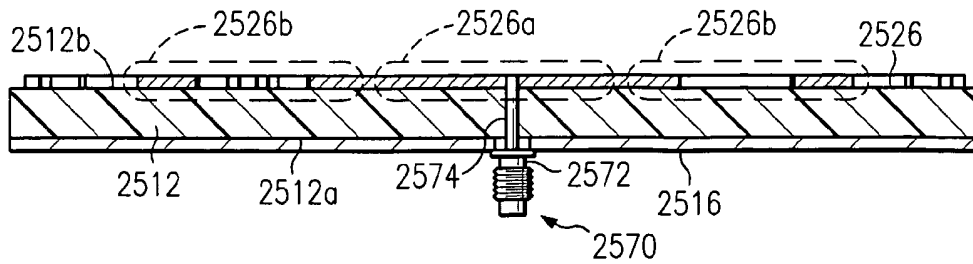

FIG. 27

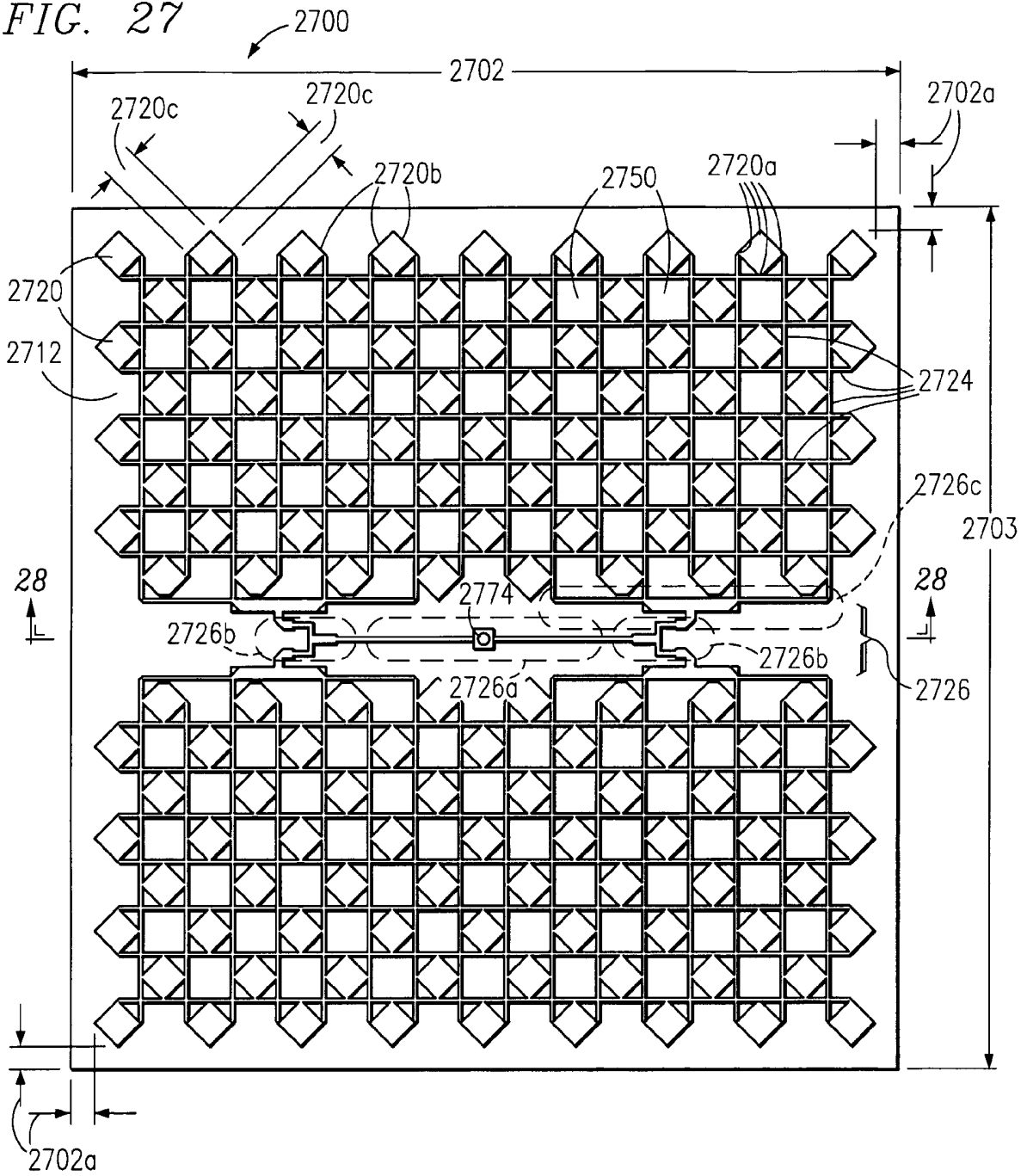
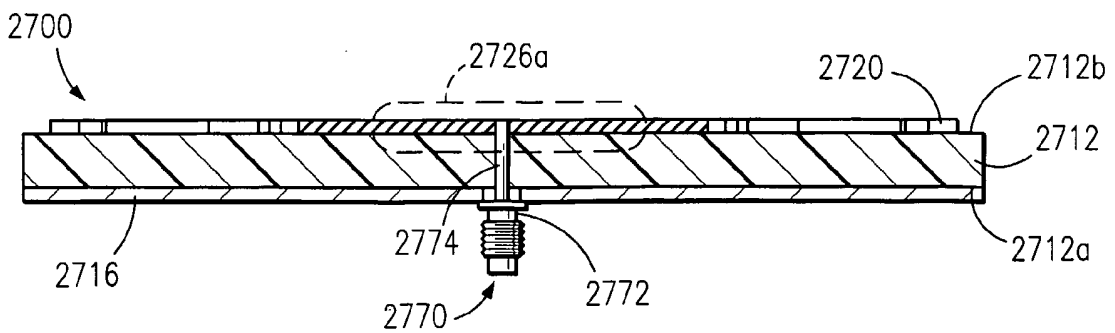

FIG. 28



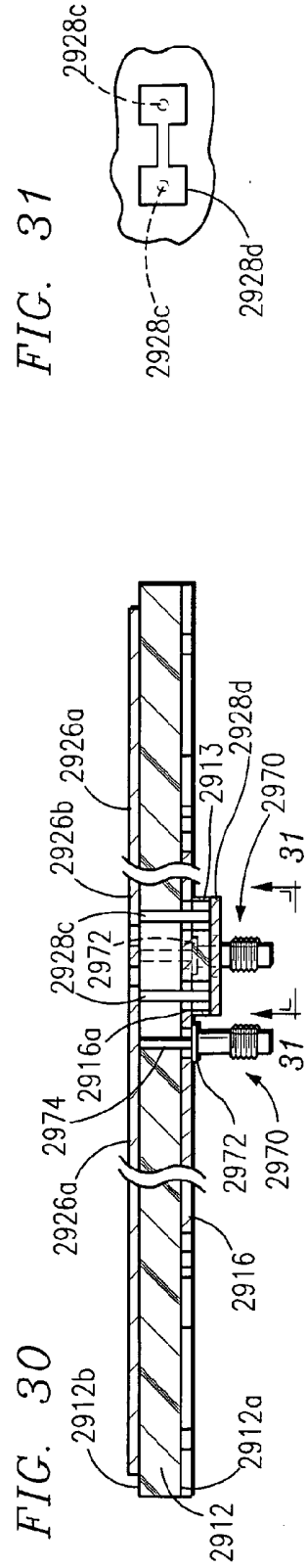
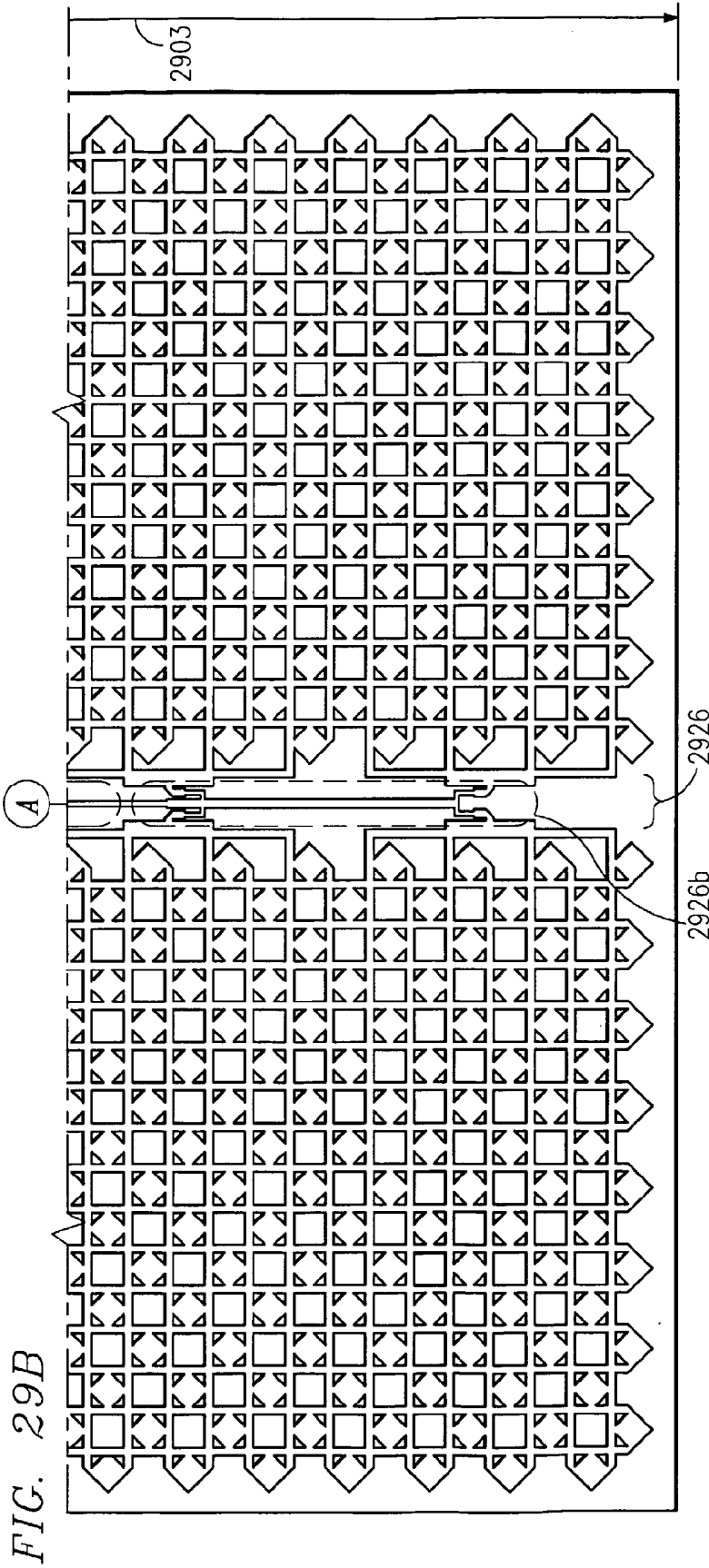

FIG. 32

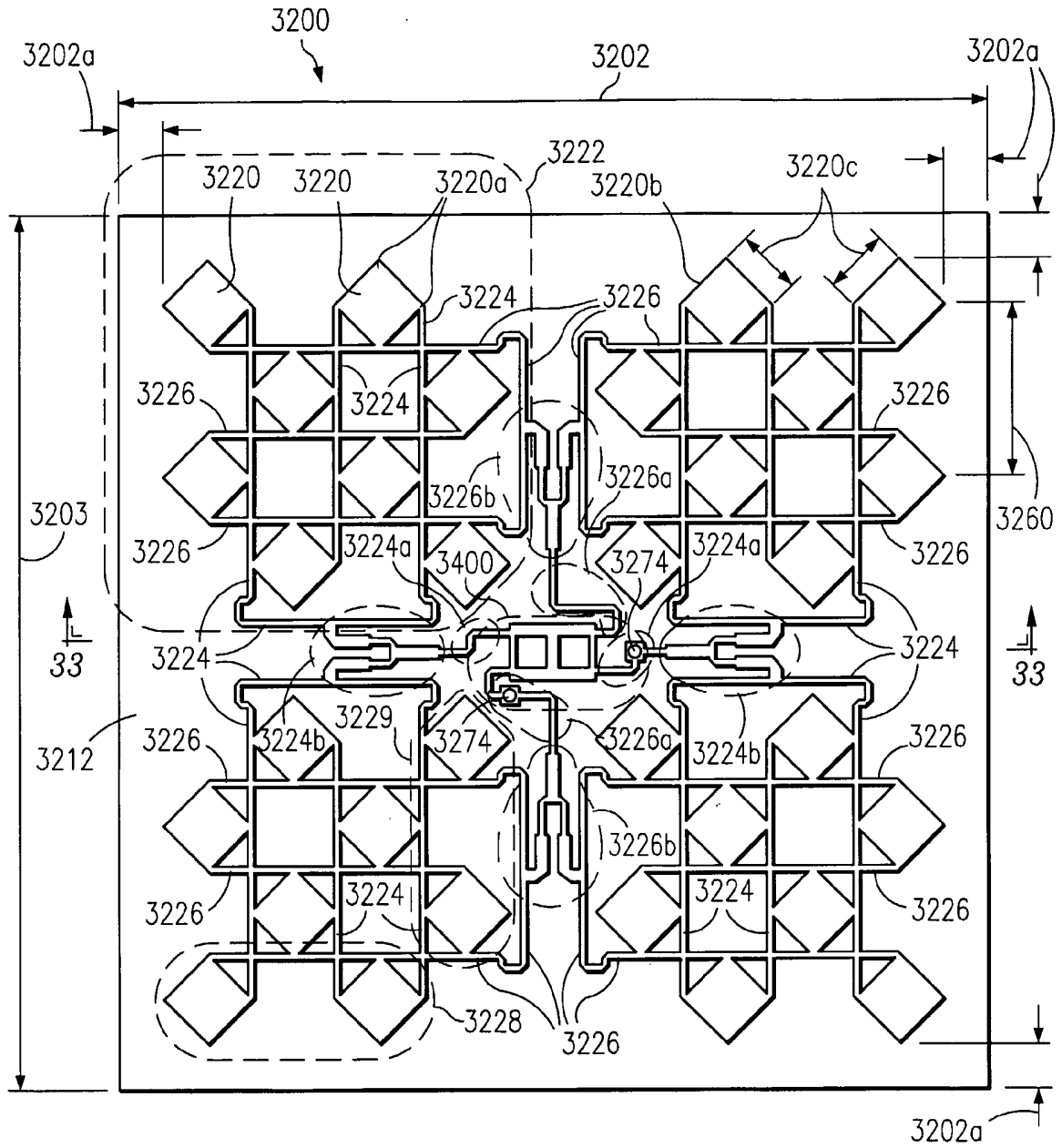

FIG. 33

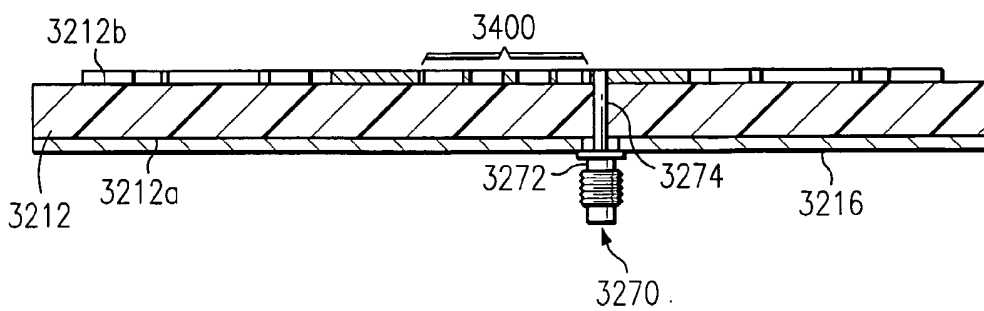

FIG. 34

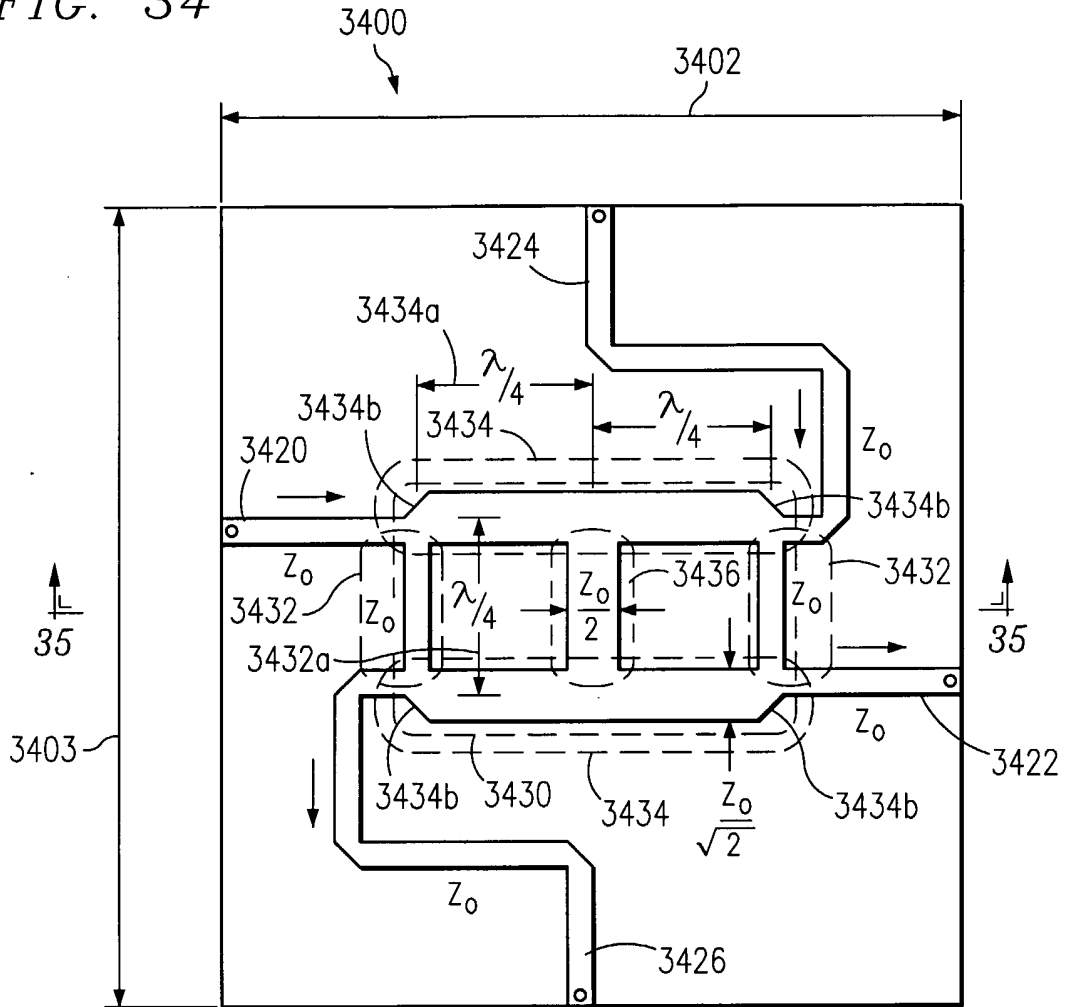
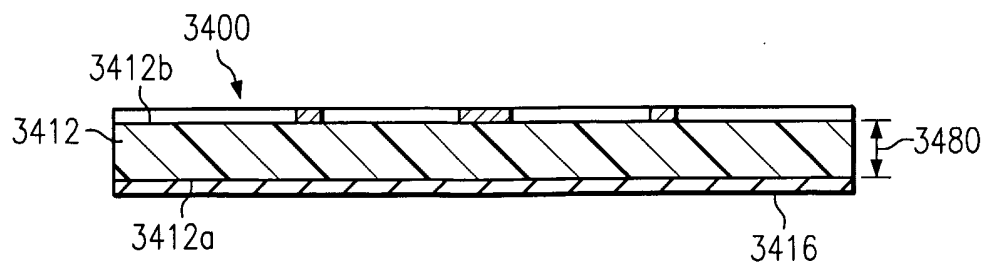

FIG. 35



INTERNATIONAL SEARCH REPORT

PCT/US2004/011934

A. CLASSIFICATION OF SUBJECT MATTER

IPC 7 H01Q21/06 H01Q1/38 H01Q21/00

According to International Patent Classification (IPC) or to both national classification and IPC

B. FIELDS SEARCHED

Minimum documentation searched (classification system followed by classification symbols)

IPC 7 H01Q

Documentation searched other than minimum documentation to the extent that such documents are included in the fields searched

Electronic data base consulted during the international search (name of data base and, where practical, search terms used)

EPO-Internal, WPI Data, PAJ, INSPEC

C. DOCUMENTS CONSIDERED TO BE RELEVANT

| Category * | Citation of document, with indication, where appropriate, of the relevant passages | Relevant to claim No. |
|------------|---|--|
| X | DANIEL J P ET AL: "ANTENNES IMPRIMEES : RESEAUX PLANS ET TECHNOLOGIE" TOUTE L'ELECTRONIQUE, SOCIETE DES EDITIONS RADIO. PARIS, FR, no. 549, 1 December 1989 (1989-12-01), pages 32-37, XP000080039 page 32, left-hand column, line 23 - page 33, left-hand column, line 28; figures 1-3 | 1-3, 8, 9, 29-35, 38, 39, 45-50 |
| Y | | 4-7, 16-22 |
| A | | 10, 15, 23-26, 36, 40, 42 |
| | ----- -/-- | |

 Further documents are listed in the continuation of box C. Patent family members are listed in annex.

* Special categories of cited documents:

A document defining the general state of the art which is not considered to be of particular relevance

E earlier document but published on or after the international filing date

L document which may throw doubts on priority claim(s) or which is cited to establish the publication date of another citation or other special reason (as specified)

O document referring to an oral disclosure, use, exhibition or other means

P document published prior to the international filing date but later than the priority date claimed

T later document published after the international filing date or priority date and not in conflict with the application but cited to understand the principle or theory underlying the invention

X document of particular relevance; the claimed invention cannot be considered novel or cannot be considered to involve an inventive step when the document is taken alone

Y document of particular relevance; the claimed invention cannot be considered to involve an inventive step when the document is combined with one or more other such documents, such combination being obvious to a person skilled in the art.

& document member of the same patent family

Date of the actual completion of the international search

3 February 2005

Date of mailing of the international search report

(1 6 . 0 2 . 0 5)

Name and mailing address of the ISA

European Patent Office, P.B. 5818 Patentlaan 2
NL - 2280 HV Rijswijk
Tel. (+31-70) 340-2040, Tx. 31 651 epo nl,
Fax: (+31-70) 340-3016

Authorized officer

Van Dooren, G

INTERNATIONAL SEARCH REPORT

PCT/US2004/011934

| C.(Continuation) DOCUMENTS CONSIDERED TO BE RELEVANT | | |
|--|--|---------------------------|
| Category ° | Citation of document, with indication, where appropriate, of the relevant passages | Relevant to claim No. |
| Y | LEGAY H ET AL: "Planar resonant series-fed arrays" IEE PROCEEDINGS: MICROWAVES, ANTENNAS AND PROPAGATION, IEE, STEVENAGE, HERTS, GB, vol. 144, no. 2, 11 April 1997 (1997-04-11), pages 67-72, XP006008752 ISSN: 1350-2417 | 4-7, 16-22 |
| A | section I Introduction ----- | 24,25 |
| X | US 5 233 361 A (BOGUAIS MARC) 3 August 1993 (1993-08-03) column 3, line 40 - column 5, line 13; figures 1,2 ----- | 1,36,37, 40-44 |
| X | US 4 173 019 A (WILLIAMS, JOHN C) 30 October 1979 (1979-10-30) ----- | 1,40,41 |
| A | | 10,15, 23,26, 36,42 |
| X | US 3 987 455 A (OLYPHANT, JR. ET AL) 19 October 1976 (1976-10-19) ----- | 1 |
| A | column 6, line 11 - column 7, line 36 ----- | 15,23,36 |
| X | US 4 605 931 A (MEAD ET AL) 12 August 1986 (1986-08-12) the whole document ----- | 27,28 |
| X | J S WIGHT ET AL: "a microstrip and stripline crossover structure" IEEE TRANSACTIONS ON MICROWAVE THEORY AND TECHNIQUES, vol. MTT-24, no. 5, May 1976 (1976-05), page 270. XP002316176 PISCATAWAY, NEW YORK, USA the whole document ----- | 27,28 |
| A | SHUN-SHI ZHONG ET AL: "CORNER-FED MICROSTRIP ANTENNA ELEMENT AND ARRAYS FOR DUAL-POLARIZATION OPERATION" IEEE TRANSACTIONS ON ANTENNAS AND PROPAGATION, IEEE INC. NEW YORK, US, vol. 10, no. 50, October 2002 (2002-10), pages 1473-1480, XP001141171 ISSN: 0018-926X section III: dual-polarized corner-fed microstrip arrays ----- | |
| A | FR 2 799 580 A (UNIV RENNES) 13 April 2001 (2001-04-13) figures 1-6 ----- | |
| | ----- -/-- ----- | |

INTERNATIONAL SEARCH REPORT

PCT/US2004/011934

| C.(Continuation) DOCUMENTS CONSIDERED TO BE RELEVANT | | |
|--|---|-----------------------|
| Category ° | Citation of document, with indication, where appropriate, of the relevant passages | Relevant to claim No. |
| A | <p>DANIEL J P ET AL: "Printed antenna arrays: examples of commercial applications" ANTENNAS AND PROPAGATION FOR WIRELESS COMMUNICATIONS, 1998. 1998 IEEE-APS CONFERENCE ON WALTHAM, MA, USA 1-4 NOV. 1998, NEW YORK, NY, USA, IEEE, US, 1 November 1998 (1998-11-01), pages 105-108, XP010313953 ISBN: 0-7803-4955-5</p> <p style="text-align: center;">-----</p> | |
| E,L | <p>US 2004/080455 A1 (LEE CHOON SAE) 29 April 2004 (2004-04-29) the whole document L: priority</p> <p style="text-align: center;">-----</p> | 1-50 |

INTERNATIONAL SEARCH REPORT

PCT/US2004/011934

Box II Observations where certain claims were found unsearchable (Continuation of item 2 of first sheet)

This International Search Report has not been established in respect of certain claims under Article 17(2)(a) for the following reasons:

1. Claims Nos.:
because they relate to subject matter not required to be searched by this Authority, namely:

2. Claims Nos.:
because they relate to parts of the International Application that do not comply with the prescribed requirements to such an extent that no meaningful International Search can be carried out, specifically:

3. Claims Nos.:
because they are dependent claims and are not drafted in accordance with the second and third sentences of Rule 6.4(a).

Box III Observations where unity of invention is lacking (Continuation of item 3 of first sheet)

This International Searching Authority found multiple inventions in this international application, as follows:

see additional sheet

1. As all required additional search fees were timely paid by the applicant, this International Search Report covers all searchable claims.
2. As all searchable claims could be searched without effort justifying an additional fee, this Authority did not invite payment of any additional fee.
3. As only some of the required additional search fees were timely paid by the applicant, this International Search Report covers only those claims for which fees were paid, specifically claims Nos.:
4. No required additional search fees were timely paid by the applicant. Consequently, this International Search Report is restricted to the invention first mentioned in the claims; it is covered by claims Nos.:

Remark on Protest

The additional search fees were accompanied by the applicant's protest.

No protest accompanied the payment of additional search fees.

FURTHER INFORMATION CONTINUED FROM PCT/ISA/ 210

This International Searching Authority found multiple (groups of) inventions in this international application, as follows:

1. claims: 1-9,16-22, 24, 25, 29-35, 38, 39, 45-50

directed to patch feeding

2. claims: 10-15, 23, 26, 36, 37, 40-44

directed to dual polarisation

3. claims: 27,28

directed to a directional coupler

INTERNATIONAL SEARCH REPORT

PCT/US2004/011934

| Patent document cited in search report | | Publication date | Patent family member(s) | Publication date |
|---|----|---------------------|----------------------------|---------------------|
| US 5233361 | A | 03-08-1993 | FR 2652204 A1 | 22-03-1991 |
| | | | DE 69024022 D1 | 18-01-1996 |
| | | | DE 69024022 T2 | 27-06-1996 |
| | | | EP 0423853 A1 | 24-04-1991 |
| | | | JP 3000168 B2 | 17-01-2000 |
| | | | JP 3238904 A | 24-10-1991 |
| | | | US 4173019 | A |
| | | | AU 509943 B2 | 29-05-1980 |
| | | | AU 3307378 A | 16-08-1979 |
| | | | BE 863819 A1 | 09-08-1978 |
| | | | CA 1099014 A1 | 07-04-1981 |
| | | | CH 627304 A5 | 31-12-1981 |
| | | | DE 2803900 A1 | 17-08-1978 |
| | | | FR 2380648 A1 | 08-09-1978 |
| | | | IT 1092583 B | 12-07-1985 |
| | | | JP 1307449 C | 13-03-1986 |
| | | | JP 53099750 A | 31-08-1978 |
| | | | JP 60028444 B | 04-07-1985 |
| | | | NL 7801314 A | 15-08-1978 |
| | | | SE 439562 B | 17-06-1985 |
| | | | SE 7801436 A | 12-08-1978 |
| US 3987455 | A | 19-10-1976 | NONE | |
| US 4605931 | A | 12-08-1986 | AU 576240 B2 | 18-08-1988 |
| | | | AU 4227485 A | 20-03-1986 |
| | | | CA 1234621 A1 | 29-03-1988 |
| | | | DE 3531474 A1 | 27-03-1986 |
| | | | FR 2571551 A1 | 11-04-1986 |
| | | | GB 2164498 A ,B | 19-03-1986 |
| | | | IL 75041 A | 31-01-1989 |
| | | | IT 1200682 B | 27-01-1989 |
| | | | JP 1768846 C | 30-06-1993 |
| | | | JP 4049802 B | 12-08-1992 |
| | | | JP 61072405 A | 14-04-1986 |
| | | | NO 852003 A ,B, | 17-03-1986 |
| | | | SE 461492 B | 19-02-1990 |
| | | | SE 8504123 A | 15-03-1986 |
| FR 2799580 | A | 13-04-2001 | FR 2799580 A1 | 13-04-2001 |
| | | | AU 7672100 A | 23-04-2001 |
| | | | EP 1226626 A1 | 31-07-2002 |
| | | | WO 0128039 A1 | 19-04-2001 |
| US 2004080455 | A1 | 29-04-2004 | NONE | |