



- (51) International Patent Classification:
B65G 1/04 (2006.01) *B65G 1/137* (2006.01)
- (21) International Application Number:
PCT/US2018/024065
- (22) International Filing Date:
23 March 2018 (23.03.2018)
- (25) Filing Language: English
- (26) Publication Language: English
- (30) Priority Data:
62/475,444 23 March 2017 (23.03.2017) US
- (71) Applicant: **BERKSHIRE GREY, INC.** [US/US]; 10 Maguire Road, Building 4, Suite 190, Lexington, MA 02421 (US).

- (72) Inventors: **WAGNER, Thomas**; 97 Alden Road, Concord, MA 01742 (US). **AHEARN, Kevin**; 378 Bloomsbury Circle, Camden, SC 29020 (US). **AMEND, John, Richard**; 49 Hill Road, Apartment #47, Belmont, MA 02478 (US). **COHEN, Benjamin**; 34 Belmont Street #2, Somerville, MA 02143 (US). **DAWSON-HAGGERTY, Michael**; 333 S. Highland Avenue #501, Pittsburgh, PA 15206 (US). **FORT, William, Hartman**; 15 Country Farm Road, Stratham, NH 03885 (US). **GEYER, Christopher**; 56 Churchill Avenue, Arlington, MA 02476 (US). **KING, Jennifer, Eileen**; 600 9th Street, Oakmont, PA 15139 (US). **KOLETSCHKA, Thomas**; 124 Rindge Avenue #33, Cambridge, MA 02140 (US). **KOVAL, Michael, Cap**; 5537 Bartlett Street, Apartment #1, Pittsburgh, PA 15217 (US). **MARONEY, Kyle**; 118 Weena Road, North Attleboro, MA 02760 (US). **MASON, Matthew, T.**; 3060 Beechwood Boulevard, Pittsburgh, PA 15217 (US). **MCMAHAN, William, Hyon-chu**; 146 Dudley Street, Apartment

(54) Title: SYSTEMS AND METHODS FOR PROCESSING OBJECTS, INCLUDING AUTOMATED MOBILE MATRIX CARRIERS

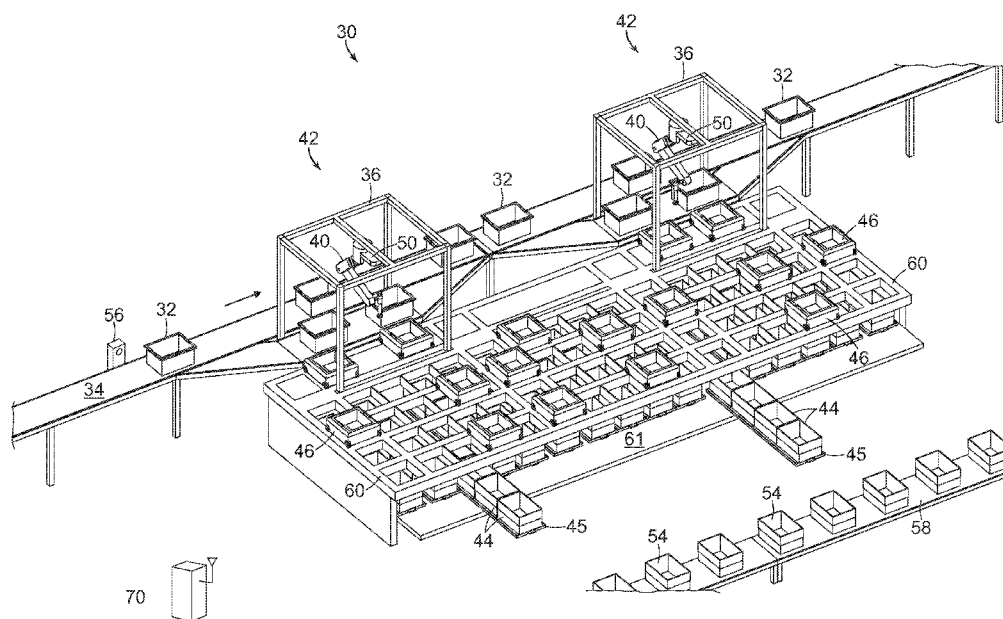

FIG. 2

(57) Abstract: A processing system for processing objects using a programmable motion device is disclosed. The processing system includes a perception unit for perceiving identifying indicia representative of an identity of a plurality of objects received from an input conveyance system, and an acquisition system for acquiring an object from the plurality of objects at an input area using an end effector of the programmable motion device. The programmable motion device is adapted for assisting in the delivery of the object to an identified processing location. The identified processing location is associated with the identifying indicia and the identified processing location is provided as one of a plurality of processing locations. The system also includes a delivery system for receiving the object in a carrier and for delivering the object toward the identified processing location.



#2, Cambridge, MA 02140 (US). **PRICE, Gene, Temple**; 155 Elm Street, Somerville, MA 02144 (US). **ROMANO, Joseph**; 115 Belmont Street #1, Somerville, MA 02143 (US). **SMITH, Daniel**; 5240 Stanton Avenue #311, Pittsburgh, PA 15201 (US). **SRINIVASA, Siddhartha**; 6341 Burchfield Avenue, Pittsburgh, PA 15217 (US). **VELAGAPUDI, Prasanna**; 5836 Northumberland Street, Pittsburgh, PA 15217 (US). **ALLEN, Thomas**; 177 Woburn Street, Reading, MA 01867 (US).

(74) **Agent: HILTON, William, E.** et al.; Gesmer Updegrove LLP, 40 Broad Street, Boston, MA 02109 (US).

(81) **Designated States** (*unless otherwise indicated, for every kind of national protection available*): AE, AG, AL, AM, AO, AT, AU, AZ, BA, BB, BG, BH, BN, BR, BW, BY, BZ, CA, CH, CL, CN, CO, CR, CU, CZ, DE, DJ, DK, DM, DO, DZ, EC, EE, EG, ES, FI, GB, GD, GE, GH, GM, GT, HN, HR, HU, ID, IL, IN, IR, IS, JO, JP, KE, KG, KH, KN, KP, KR, KW, KZ, LA, LC, LK, LR, LS, LU, LY, MA, MD, ME, MG, MK, MN, MW, MX, MY, MZ, NA, NG, NI, NO, NZ, OM, PA, PE, PG, PH, PL, PT, QA, RO, RS, RU, RW, SA, SC, SD, SE, SG, SK, SL, SM, ST, SV, SY, TH, TJ, TM, TN, TR, TT, TZ, UA, UG, US, UZ, VC, VN, ZA, ZM, ZW.

(84) **Designated States** (*unless otherwise indicated, for every kind of regional protection available*): ARIPO (BW, GH, GM, KE, LR, LS, MW, MZ, NA, RW, SD, SL, ST, SZ, TZ, UG, ZM, ZW), Eurasian (AM, AZ, BY, KG, KZ, RU, TJ, TM), European (AL, AT, BE, BG, CH, CY, CZ, DE, DK, EE, ES, FI, FR, GB, GR, HR, HU, IE, IS, IT, LT, LU, LV, MC, MK, MT, NL, NO, PL, PT, RO, RS, SE, SI, SK, SM, TR), OAPI (BF, BJ, CF, CG, CI, CM, GA, GN, GQ, GW, KM, ML, MR, NE, SN, TD, TG).

Published:

— with international search report (Art. 21(3))

SYSTEMS AND METHODS FOR PROCESSING OBJECTS, INCLUDING
AUTOMATED MOBILE MATRIX CARRIERS

PRIORITY

The present application claims priority to U.S. Provisional Patent Application Ser. No. 62/475,444 filed March 23, 2017, the disclosure of which is hereby incorporated by reference in its entirety.

BACKGROUND

The invention generally relates to automated programmable motion control systems, e.g., robotic, sortation and other processing systems, and relates in particular to programmable motion control systems intended for use in environments requiring that a variety of objects (e.g., articles, packages, consumer products etc.) be processed and moved to a number of processing destinations.

Many object distribution systems, for example, receive objects in a disorganized stream or bulk transfer that may be provided as individual objects or objects aggregated in groups such as in bags, arriving on any of several different conveyances, commonly a conveyor, a truck, a pallet a Gaylord, or a bin etc. Each object must then be distributed to the correct destination location (e.g., a container) as determined by identification information associated with the object, which is commonly determined by a label printed on the object. The destination location may take many forms, such as a bag, a shelf, a container, or a bin.

The processing (e.g., sortation or distribution) of such objects has traditionally been done, at least in part, by human workers that scan the objects, for example with a hand-held barcode scanner, and then place the objects at assigned locations. Many order fulfillment operations, for example, achieve high efficiency by employing a process called wave picking. In wave picking, orders are picked from warehouse shelves and placed at locations (e.g., into

bins) containing multiple orders that are sorted downstream. At the sorting stage, individual articles are identified, and multi-article orders are consolidated, for example, into a single bin or shelf location, so that they may be packed and then shipped to customers. The process of sorting these articles has traditionally been done by hand. A human sorter picks an article, and then places the article in the so-determined bin or shelf location where all articles for that order or manifest have been defined to belong. Automated systems for order fulfillment have also been proposed. See, for example, U.S. Patent Application Publication No. 2014/0244026, which discloses the use of a robotic arm together with an arcuate structure that is movable to within reach of the robotic arm.

The identification of objects by code scanning generally either require manual processing, or require that the code location be controlled or constrained so that a fixed or robot-held code scanner (e.g., a barcode scanner) can reliably detect the code. Manually operated barcode scanners are therefore generally either fixed or handheld systems. With fixed systems, such as those at *point-of-sale* systems, the operator holds the article and places it in front of the scanner, which scans continuously, and decodes any barcodes that it can detect. If the article's code is not immediately detected, the person holding the article typically needs to vary the position or orientation of the article with respect to the fixed scanner, so as to render the barcode more visible to the scanner. For handheld systems, the person operating the scanner may look at the barcode on the article, and then hold the article such that the barcode is within the viewing range of the scanner, and then press a button on the handheld scanner to initiate a scan of the barcode.

Further, many distribution center sorting systems generally assume an inflexible sequence of operation whereby a disorganized stream of input objects is provided (by a human) as a singulated stream of objects that are oriented with respect to a scanner that identifies the objects. An induction element or elements (e.g., a conveyor, a tilt tray, or manually movable

bins) transport the objects to desired destination locations or further processing stations, which may be a bin, a chute, a bag or a conveyor etc.

In conventional object sortation or distribution systems, human workers or automated systems typically retrieve objects in an arrival order, and sort each object or object into a collection bin based on a set of given heuristics. For example, all objects of a like type might be directed to a particular collection bin, or all objects in a single customer order, or all objects destined for the same shipping destination, etc. may be directed to a common destination location. Generally, the human workers, with the possible limited assistance of automated systems, are required to receive objects and to move each to their assigned collection bin. If the number of different types of input (received) objects is large, then a large number of collection bins is required.

Figure 1 for example, shows an object distribution system 10 in which objects arrive, e.g., in trucks, as shown at 12, are separated and stored in packages that each include a specific combination of objects as shown at 14, and the packages are then shipped as shown at 16 to different retail stores, providing that each retail store receives a specific combination of objects in each package. Each package received at a retail store from transport 16, is broken apart at the store and such packages are generally referred to as *break-packs*. In particular, incoming trucks 12 contain vendor cases 18 of homogenous sets of objects. Each vendor case, for example, may be provided by a manufacturer of each of the objects. The objects from the vendor cases 18 are moved into decanted bins 20, and are then brought to a processing area 14 that includes break-pack store packages 22. At the processing area 14, the break-pack store packages 22 are filled by human workers that select items from the decanted vendor bins to fill the break-pack store packages according to a manifest. For example, a first set of the break-pack store packages may go to a first store (as shown at 24), and a second set of break-pack store packages may go to a second store (as shown at 26). In this way, the system may accept

large volumes of product from a manufacturer, and then re-package the objects into break-packs to be provided to retail stores at which a wide variety of objects are to be provided in a specific controlled distribution fashion.

Such a system however, has inherent inefficiencies as well as inflexibilities since the desired goal is to match incoming objects to assigned collection bins. Such systems may require a large number of collection bins (and therefore a large amount of physical space, large investment costs, and large operating costs), in part, because sorting all objects to all destinations at once is not always most efficient. Additionally, such break-pack systems must also monitor the volume of each like object in a bin, requiring that a human worker continuously count the items in a bin.

Further, current *state-of-the-art* sortation systems also rely in human labor to some extent. Most solutions rely on a worker that is performing sortation, by scanning each object from an induction area (chute, table, etc.) and placing each object at a staging location, conveyor, or collection bin. When a bin is full, another worker empties the bin into a bag, box, or other container, and sends that container on to the next processing step. Such a system has limits on throughput (i.e., how fast can human workers sort to or empty bins in this fashion) and on number of diverts (i.e., for a given bin size, only so many bins may be arranged to be within efficient reach of human workers).

Unfortunately, these systems do not address the limitations of the total number of system bins. The system is simply diverting an equal share of the total objects to each parallel manual cell. Thus, each parallel sortation cell must have all the same collection bin designations; otherwise, an object may be delivered to a cell that does not have a bin to which the object is mapped. There remains a need, therefore, for a more efficient and more cost effective object processing system that processes objects of a variety of sizes and weights into

appropriate collection bins or trays of fixed sizes, yet is efficient in handling objects of varying sizes and weights.

SUMMARY

In accordance with an embodiment, the invention provides a processing system for processing objects using a programmable motion device. The processing system includes a perception unit for perceiving identifying indicia representative of an identity of a plurality of objects received from an input conveyance system, and an acquisition system for acquiring an object from the plurality of objects at an input area using an end effector of the programmable motion device. The programmable motion device is adapted for assisting in the delivery of the object to an identified processing location. The identified processing location is associated with the identifying indicia and the identified processing location is provided as one of a plurality of processing locations. The system also includes a delivery system for receiving the object in a carrier and for delivering the object toward the identified processing location.

In accordance with another embodiment, the invention provides a processing system for processing objects using a programmable motion device, where the processing system includes a perception unit for perceiving identifying indicia representative of an identity of a plurality of objects associated with an input conveyance system, an acquisition system for acquiring an object from the plurality of objects at an input area using an end effector of the programmable motion device, wherein the programmable motion device is adapted for assisting in the delivery of the object to an identified processing location, the identified processing location is associated with the identifying indicia and said identified processing location being provided as one of a plurality of processing locations, and a delivery system delivering the object to the identified processing location, where the delivery system includes

a plurality of carriers that are individually movable in at least two dimensions, and any of which carriers may contain the object.

In accordance with a further embodiment, the invention provides a method of processing objects using a programmable motion device. The method includes the steps of perceiving identifying indicia representative of an identity of a plurality of objects received from an input conveyance system, acquiring an object from the plurality of objects at an input area using an end effector of the programmable motion device, wherein the programmable motion device is adapted for assisting in the delivery of the object to an identified processing location, and the identified processing location being associated with the identifying indicia and said identified processing location being provided as one of a plurality of processing locations, and delivering the object toward the identified processing location, where the step of delivering the object toward the identified processing location including receiving the object in a carrier.

BRIEF DESCRIPTION OF THE ILLUSTRATED EMBODIMENTS

The following description may be further understood with reference to the accompanying drawings in which:

Figure 1 shows an illustrative diagrammatic view of an object processing system of the prior art;

Figure 2 shows an illustrative diagrammatic view of an object processing system in accordance with an embodiment of the invention;

Figure 3 shows an illustrative diagrammatic view of an object processing station in system in accordance with an embodiment of the present invention;

Figure 4 shows an illustrative diagrammatic view of a carrier for use in accordance with an embodiment of the present invention;

Figure 5 shows an illustrative diagrammatic top view of the carrier of Figure 4;

Figure 6 shows an illustrative diagrammatic view of the carrier of Figure 4 with the containment doors opened;

Figure 7 shows an illustrative diagrammatic top view of a carrier of use in accordance with another embodiment of the present invention involving tracking sensors;

Figure 8 shows an illustrative diagrammatic top view of the carrier of Figure 7;

Figure 9 shows an illustrative diagrammatic bottom view of the carrier of Figure 7;

Figure 10 shows an illustrative diagrammatic view of an underside of a perception system of Figures 2 and 3;

Figure 11 shows an illustrative diagrammatic view from the perception system of Figure 10, showing a view of objects within a bin of objects to be processed;

Figures 12A and 12B show an illustrative diagrammatic view of a grasp selection process in an object processing system of an embodiment of the present invention;

Figures 13A and 13B show an illustrative diagrammatic view of a grasp planning process in an object processing system of an embodiment of the present invention;

Figures 14A and 14B show an illustrative diagrammatic view of a grasp execution process in an object processing system of an embodiment of the present invention;

Figure 15 shows an illustrative diagrammatic view of an object processing system in accordance with a further embodiment of the present invention;

Figure 16 shows an illustrative diagrammatic isometric view of the carrier of Figure 15 with the containment doors in a closed position;

Figure 17 shows an illustrative diagrammatic isometric view of the carrier of Figure 16 with the containment doors in an open position;

Figures 18A and 18B show illustrative diagrammatic isometric views of the carrier of Figure 16 with the wheel assemblies in each of two different pivotal positions;

Figures 19A and 19B show illustrative diagrammatic side views of the carrier shown in Figures 18A and 18B taken along lines 19A – 19A and 19B – 19B respectively;

Figures 20A and 20B show illustrative diagrammatic end views of the carrier shown in Figures 18A and 18B taken along lines 20A – 20A and 20B – 20B respectively;

Figures 21A and 21B show illustrative diagrammatic bottom views of the carrier shown in Figures 18A and 18B respectively;

Figures 22A – 22C show illustrative diagrammatic views of the carrier of Figure 16 at different stages of engaging an adjacent track section during movement;

Figure 23 shows an illustrative diagrammatic view of guide rollers of the carrier of Figure 16 engaging a track section;

Figure 24 shows an illustrative diagrammatic view of a carrier in accordance with a further embodiment of the invention involving a carrier conveyor;

Figure 25 shows an illustrative diagrammatic view of a carrier in accordance with a further embodiment of the invention involving a carrier with a tipping surface;

Figure 26 shows an illustrative diagrammatic top view of an object processing system in accordance with another embodiment of the invention that identifies changing and unchanging motion planning general areas;

Figure 27 shows an illustrative diagrammatic top view of the system of Figure 24 showing multiple possible paths from the programmable motion device to a destination carrier;

Figure 28 shows an illustrative diagrammatic top view of the system of Figure 24, showing paths from the programmable motion device to a destination carrier with an emphasis on minimum time;

Figure 29 shows an illustrative diagrammatic top view of the system of Figure 24, showing paths from the programmable motion device to a destination carrier with an emphasis on minimum risk;

Figure 30 shows an illustrative diagrammatic view of an object assignment relationships in a conventional sortation system;

Figure 31 shows an illustrative diagrammatic view of an object assignment relationships in accordance with certain embodiments of the present invention;

Figure 32 shows an illustrative diagrammatic view of an object assignment system of Figure 30;

Figures 33A – 33I show illustrative diagrammatic views of object assignment steps in system in accordance with certain embodiments of the present invention;

Figure 34 shows an illustrative flowchart of a process in accordance with an embodiment of the present invention; and

Figure 35 shows an illustrative flowchart of an overall method of providing dynamic processing of objects;

The drawings are shown for illustrative purposes only.

DETAILED DESCRIPTION

In accordance with an embodiment, the invention provides a method of processing objects using a programmable motion device. The method includes the steps of perceiving identifying indicia representative of an identity of a plurality of objects and directing the plurality of objects toward an input area from at least one input conveyance system, acquiring an object from the plurality of objects at the input area using an end effector of the programmable motion device, and moving the acquired object toward an identified processing location using the programmable motion device, said identified processing location beings associated with the identifying indicia and said identified processing location being provided as one of a plurality of processing locations along a first direction, and said step of moving the

acquired object including moving the programmable motion device along a second direction that is substantially parallel with the first direction.

Generally, objects need to be identified and conveyed to desired object specific locations. The systems reliably automate the identification and conveyance of such objects, employing in certain embodiments, a set of conveyors, a perception system, and a plurality of destination bins. In short, applicants have discovered that when automating sortation of objects, there are a few main things to consider: 1) the overall system throughput (objects sorted per hour), 2) the number of diverts (i.e., number of discrete locations to which an object can be routed), 3) the total area of the sortation system (square feet), and 4) the capital and annual costs to purchase and run the system.

Processing objects in a break-pack distribution center is one application for automatically identifying and processing objects. As noted above, in a break-pack distribution center, objects commonly arrive in trucks, are conveyed to sortation stations where they are sorted according to desired destinations into boxes (or packages) that are then loaded in trucks for transport to, for example, shipping or distribution centers or retail stores. In a shipping or distribution center, the desired destination is commonly obtained by reading identifying information printed on the box or package. In this scenario, the destination corresponding to identifying information is commonly obtained by querying the customer's information system. In other scenarios, the destination may be written directly on the box, or may be known through other means such as by assignment to a vendor bin.

The system also requests specific bins of objects from a storage system, which helps optimize the process of having desired objects be delivered to specific singulator cells in an efficient way without simply letting all bins of objects appear at each singulator cell in a purely random order.

Figure 2, for example, shows a system 30 in accordance with an embodiment of the present invention that receives decanted vendor bins 32 on an in-feed conveyor 34 that pass by a plurality of processing stations 42. One (or more) programmable motion devices 40 such as an articulated arm having an end effector is provided suspended from a support frame 36. Adjacent a base of the articulated arm and also suspended from the support frame 36 is a perception unit 50 (as further discussed below with reference to Figure 5). Additional perception units 56 may be provided (for example, near vendor bin in-feed conveyor 34) that capture perception information regarding a label that is applied to each bin 32 that associates the bin with the contents of the bin.

The programmable motion device is programmed to access each of the vendor bins 32 and to move any of the objects in bins 32 at input areas 38 to one of a plurality of carriers 46 at one or more processing locations near the device 40 (as further shown in Figure 3). Each carrier 46 is an automated mobile device, and once an object has been placed in a carrier 46, the carrier returns to a matrix track.

In accordance with an embodiment, the carrier 46 that receives an object then delivers the object to an assigned package 44 by moving the carrier 46 over the assigned package 44. When the carrier 46 is over the appropriate package 44, the carrier opens a bomb-bay door 47 in its floor to drop the contents of the carrier 46 into the associated package 44. In accordance with a further embodiment each carrier 46 may receive a plurality of objects that are destined for the same package 44. Each carrier may be called to any number of processing stations 42 until the carrier is full or completed and ready to drop its contents into the appropriate package 44. In this case, again, when a carrier 46 is ready for being emptied (e.g., it is expected that no further objects for a specific package will be presented), the system will cause the carrier 46 to move over an associated package 44 that lies under the track 60.

When each package 44 is complete or full, the package may be loaded onto an output conveyor 61 by a human worker that pulls out a drawer 45 of packages, and loads the completed package onto the conveyor, replacing it with an empty package 54 that is now ready for processing according to a central manifest. Because the system knows how many packages 44 fit on a drawer and where those packages are when the drawer is closed, and because the track system 60 provides openings above the packages locations, the system knows where each individual package is located, and is able to have any carrier bring its contents to any package. When sitting over a destination package, the carrier simply opens the floor and drops its contents into a destination package.

With further reference to Figure 3, at each processing station 42 one or more vendor bins 32 are routed to an input area 38, and a programmable motion device 40 is actuated to grasp an object from a bin 32, and to place the object into a carrier 46. The processed vendor bins are then returned to a common input stream, and the carrier 46 that received the object is moved away from the processing station 42.

Each automated mobile carrier 46 is able to move about the X – Y track 60 with freedom of movement (but for requiring that the control system accommodate moving other mobile devices to make appropriate paths). As shown in Figure 4 each automated mobile carrier 46 may include a pair of bomb-bay style doors 47 for dropping its contents into a package below, as well as a set of wheels that permit the carrier 46 to move about the track 60. As further shown in Figure 4, each wheel may be a controllable omnidirectional wheel 62, such as the Mecanum wheels sold by Mecanum AB of Sweden. Each wheel 62 is generally a conventional wheel with a series of controllable rollers 64 attached to the circumference of each wheel. While the wheels 62 provide movement in mutually opposing direction as a conventional wheel (e.g., directions shown at *C* and *D* in Figure 5), actuation of the rollers 64 provide movement in orthogonal mutually opposing directions (e.g., directions shown at *A* and *B* in Figure 5),

facilitating movement of the carriers 46 about the track 60. In further embodiments, the carrier may turn by operating opposing wheels in mutually reverse directions. Figure 6 shows the carrier 46 with the doors 47 open so that an object may be dropped by the carrier.

In accordance with another embodiment and with reference to Figures 7 - 9, the invention may provide a carrier 66 that includes a pair of bomb-bay style doors 67 and omnidirectional wheels 62, 64 as discussed above. The carrier 66 may also include four illumination sources 69 for illuminating the track (or a line printed on the track) below each source. Figure 8 shows a top view of the carrier 66, showing the position of each of the illumination sources 69. Figure 9 shows an underside of the carrier 66, which shows four pairs of illumination sensors 71. As the carrier 66 moves over a track, the system monitors the amount of light being received at each pair of underside sensors to determine if the amount of illumination being received by each of the pair is generally the same. If much more illumination is received by one of a pair, the system may assume that the carrier has run off course. Having two such pairs for a painted track line, provides further robustness to the system. Actuation of the doors may be provided by a door actuators 70. Additionally, sensors (or indicia) may be provided on the underside of each carrier for communicating with any of indicia (or sensors) on the track. This may assist in providing further security in confirming the location of a carrier, and/or in providing turning instructions to a carrier.

It is assumed that the bins of objects are marked in one or more places on their exterior with a visually distinctive mark such as a barcode (e.g., providing a UPC code) or radio-frequency identification (RFID) tag or mailing label so that they may be sufficiently identified with a scanner for processing. The type of marking depends on the type of scanning system used, but may include 1D or 2D code symbologies. Multiple symbologies or labeling approaches may be employed. The types of scanners employed are assumed to be compatible with the marking approach. the marking, e.g. by barcode, RFID tag, mailing label or other

means, encodes a identifying indicia (e.g., a symbol string), which is typically a string of letters and/or numbers. The symbol string uniquely associates the vendor bin with a specific set of homogenous objects.

The operations of the system described above are coordinated with a central control system 70 as shown in Figure 2 that communicates wirelessly with the articulated arm 40, the perception units 50 and 56, as well as in-feed conveyor 34 and the automated mobile carriers 46. This system determines from symbol strings the UPC associated with a vendor bin, as well as the outbound destination for each object. The central control system 70 is comprised of one or more workstations or central processing units (CPUs). For example, the correspondence between UPCs or mailing labels, and outbound destinations is maintained by a central control system in a database called a manifest. The central control system maintains the manifest by communicating with a warehouse management system (WMS). The manifest provides the outbound destination for each in-bound object.

As discussed above, the system of an embodiment includes a perception system (e.g., 50) that is mounted above a bin of objects to be processed next to the base of the articulated arm 40, looking down into a bin 32. The system 50, for example and as shown in Figure 10, may include (on the underside thereof), a camera 72, a depth sensor 74 and lights 76. A combination of 2D and 3D (depth) data is acquired. The depth sensor 74 may provide depth information that may be used together with the camera image data to determine depth information regarding the various objects in view. The lights 76 may be used to remove shadows and to facilitate the identification of edges of objects, and may be all on during use, or may be illuminated in accordance with a desired sequence to assist in object identification. The system uses this imagery and a variety of algorithms to generate a set of candidate grasp locations for the objects in the bin as discussed in more detail below.

Figure 11 shows an image view from the perception unit 50. The image view shows a bin 32 in an input area (a conveyor), and the bin 32 contains objects 78, 80, 82, 84 and 86. In the present embodiment, the objects are homogenous, and are intended for distribution to different break-pack packages. Superimposed on the objects 78, 80, 82, 84, 86 (for illustrative purposes) are anticipated grasp locations 79, 81, 83 and 85 of the objects. Note that while candidate grasp locations 79, 83 and 85 appear to be good grasp locations, grasp location 81 does not because its associated object is at least partially underneath another object. The system may also not even try to yet identify a grasp location for the object 84 because the object 84 is too obscured by other objects. Candidate grasp locations may be indicated using a 3D model of the robot end effector placed in the location where the actual end effector would go to use as a grasp location as shown in Figure 11. Grasp locations may be considered good, for example, if they are close to the center of mass of the object to provide greater stability during grasp and transport, and/or if they avoid places on an object such as caps, seams etc. where a good vacuum seal might not be available.

If an object cannot be fully perceived by the detection system, the perception system considers the object to be two different objects, and may propose more than one candidate grasps of such two different objects. If the system executes a grasp at either of these bad grasp locations, it will either fail to acquire the object due to a bad grasp point where a vacuum seal will not occur (e.g., on the right), or will acquire the object at a grasp location that is very far from the center of mass of the object (e.g., on the left) and thereby induce a great deal of instability during any attempted transport. Each of these results is undesirable.

If a bad grasp location is experienced, the system may remember that location for the associated object. By identifying good and bad grasp locations, a correlation is established between features in the 2D/3D images and the idea of good or bad grasp locations. Using this data and these correlations as input to machine learning algorithms, the system may eventually

learn, for each image presented to it, where to best grasp an object, and where to avoid grasping an object.

As shown in Figures 12A and 12B, the perception system may also identify portions of an object that are the most flat in the generation of good grasp location information. In particular, if an object includes a tubular end and a flat end such as object 87, the system would identify the more flat end as shown at 88 in Figure 7B. Additionally, the system may select the area of an object where a UPC code appears, as such codes are often printed on a relatively flat portion of the object to facilitate scanning of the barcode.

Figures 13A and 13B show that for each object 90, 92, the grasp selection system may determine a direction that is normal to the selected flat portion of the object 90, 92. As shown in Figures 14A and 14B, the robotic system will then direct the end effector 94 to approach each object 90, 92 from the direction that is normal to the surface in order to better facilitate the generation of a good grasp on each object. By approaching each object from a direction that is substantially normal to a surface of the object, the robotic system significantly improves the likelihood of obtaining a good grasp of the object, particularly when a vacuum end effector is employed.

The invention provides therefore in certain embodiments that grasp optimization may be based on determination of surface normal, i.e., moving the end effector to be normal to the perceived surface of the object (as opposed to vertical or *gantry* picks), and that such grasp points may be chosen using fiducial features as grasp points, such as picking on a barcode, given that barcodes are almost always applied to a flat spot on the object.

In accordance with various embodiments therefore, the invention further provides a processing system that may learn object grasp locations from experience (and optionally human guidance). Systems designed to work in the same environments as human workers will face an enormous variety of objects, poses, etc. This enormous variety almost ensures that the robotic

system will encounter some configuration of object(s) that it cannot handle optimally; at such times, it is desirable to enable a human operator to assist the system and have the system learn from non-optimal grasps.

The system optimizes grasp points based on a wide range of features, either extracted offline or online, tailored to the gripper's characteristics. The properties of the suction cup influence its adaptability to the underlying surface, hence an optimal grasp is more likely to be achieved when picking on the estimated surface normal of an object rather than performing vertical *gantry* picks common to current industrial applications.

In addition to geometric information the system uses appearance based features as depth sensors may not always be accurate enough to provide sufficient information about graspability. For example, the system can learn the location of fiducials such as barcodes on the object, which can be used as indicator for a surface patch that is flat and impermeable, hence suitable for a suction cup. One such example is the use of barcodes on consumer products. Another example is shipping boxes and bags, which tend to have the shipping label at the object's center of mass and provide an impermeable surface, as opposed to the raw bag material, which might be slightly porous and hence not present a good grasp.

By identifying bad or good grasp points on the image, a correlation is established between features in the 2D/3D imagery and the idea of *good* or *bad* grasp points; using this data and these correlations as input to machine learning algorithms, the system can eventually learn, for each image presented to it, where to grasp and where to avoid.

This information is added to experience based data the system collects with every pick attempt, successful or not. Over time the robot learns to avoid features that result in unsuccessful grasps, either specific to an object type or to a surface/material type. For example, the robot may prefer to avoid picks on shrink wrap, no matter which object it is applied to, but may only prefer to place the grasp near fiducials on certain object types such as shipping bags.

This learning can be accelerated by off-line generation of human-corrected images. For instance, a human could be presented with thousands of images from previous system operation and manually annotate good and bad grasp points on each one. This would generate a large amount of data that could also be input into the machine learning algorithms to enhance the speed and efficacy of the system learning.

In addition to experience based or human expert based training data, a large set of labeled training data can be generated based on a detailed object model in physics simulation making use of known gripper and object characteristics. This allows fast and dense generation of graspability data over a large set of objects, as this process is not limited by the speed of the physical robotic system or human input.

In accordance with a further embodiment and with reference to Figure 15, the system may include one or more mobile carrier units 130 that carry an object 131, which may later be dropped into an designated opening that is defined by a track section 120. In particular, Each open track section 120 is mounted over an opening that leads to a package (e.g., bin or box) below. For example, object 133 is being dropped into such an opening in Figure 15. Each track 120 is generally in the form of a raised square with rounded edges, and the tracks 120 are generally closed spaced from each other (e.g., within a length or width of a mobile carrier unit 130). The track sections together form a dis-continuous track system. A computer processor 70 may control the movement of each carrier unit 130 by wireless communication. The tracks 120 may also include sensors for detecting locations of the carriers 130 on the tracks 120.

With reference to Figure 16, each carrier unit 130 includes four wheel assemblies 132, 134, 136, 138 that each include guides 10 for following the tracks 120. The carrier 130 also includes bomb-bay style actuatable doors 137 that may be opened to drop an object from the carrier as shown in Figure 17 into an opening 141. Short walls 140 may also be provided to assist in retaining an object within t carrier prior to being dropped. Each of the wheel

assemblies is pivotally mounted such that each wheel assembly may pivot 90 degrees as further discussed below.

In accordance with certain embodiments, the invention provides a plurality of mobile carriers that may include swivel mounted wheels that rotate ninety degrees to cause each mobile carrier to move forward and backward, or to move side to side. When placed on a grid, such mobile carriers may be actuated to move to all points on the grid. Figures 18A and 18B, for example, show a mobile carrier 130 that includes wheels 132, 134, 136 and 138 (also shown in Figures 21A and 21B). Each of the wheels is mounted on a motor 133, 135, 137, 139 (as best shown in Figure 21B), and the wheel and motor units (wheel assemblies) are pivotally mounted to the carrier 130 as discussed in more detail below. The wheel assemblies (each including a wheel, its motor and track guides 140) are shown in one position in Figure 18A, and are shown in a second pivoted position in Figure 18B. Figure 19A shows an end view of the carrier 130 taken along lines 19A – 19A of Figure 18A, and Figure 19B shows an end view of the carrier 130 taken along lines 19B – 19B of Figure 18B. Similarly, Figure 20A shows a side view of the carrier 130 taken along lines 20A – 20A of Figure 18A, and Figure 20B shows a side view of the carrier 130 taken along lines 20B – 20B of Figure 18B. Note that the orientation of the carrier 130 does not change when the carrier changes direction.

Figure 21A shows a bottom view of the carrier 130 with the wheels in the position as shown in Figure 18A, and Figure 21B shows a bottom view of the carrier 130 with the wheels in the position as shown in Figure 18B. Figures 21A and 21B show all of the wheels 132, 134, 136 and 138, and each of the motors 133, 135, 137 and 138 is also shown in Figure 21B. As may be seen in Figures 21A and 21B, the entire wheel assemblies including the wheel, guide rollers and the wheel motor, each pivot as a unit. The wheel assemblies are designed to be able to pivot the wheels around corners of a track section when the carrier is directly above a track section. Note that the wheels pivot around each of the corners of the track section. When the

carrier is centered over the track section, therefore, the wheels may be pivoted such that the carrier may move in a direction that is orthogonal to a prior direction without requiring that the carrier itself be turned. The orientation of the carrier is therefore maintained constant while the carrier is moved about an array of tracks sections.

The movement of the carrier 130 about an array of tracks is further discussed below with regard to Figures 22A – 22C. In short as a carrier leaves one track, it travels toward an adjacent track, and if at all misaligned, will realign itself. The realignment of the guide rollers and the tracks may function as follows. While the two sets of wheels (132, 134 and 136, 138) may be designed to move the carrier 130 in a linear direction only, some variations may occur. The tracks 120 are positioned, though intermittently, close enough to each other than when a carrier leaves one track and moves toward another 120 (as shown at *F*), its potential variation off course will be small enough that the rounded corners of the next adjacent track will urge the carrier back on course.

For example, Figure 22A shows a carrier 130 leaving a track and beginning to approach a next track 120 as the carrier moves in a direction as indicated at *E*. As shown in Figure 22B, if the alignment of the carrier 130 is off (possibly from variations in the wheels or the mounting of the wheels, the placement of the track sections or any other variable), one of the rounded corners 161 of next adjacent track 120 will become engaged by an on-coming guide wheel 140, and the rounded corner 160 will cause the carrier 130 to move slightly in a direction (as shown at *G*) perpendicular to the direction *E* to correct the direction of movement of the carrier 130. If a carrier does stop moving, the directions of movement of the other carriers are programmed to avoid the area of the stopped carrier until it is removed. If an area results in a number of stopped carriers over time, the alignment of the track(s) in the area may be examined and/or replaced.

Figure 22C shows the carrier 130 moving in a direction F as properly realigned by the track 120. Figure 23 shows a close up view of the wheel 134 moving in a direction as shown at H to cause the carrier to move in the direction F , and further shows that the guide rollers 140 roll against the track 120 in directions as shown at I . The guide rollers 100 do not touch the ground (as does the wheel 134), but simply guide the direction of the carrier 130 by being urged against the track 120. In further embodiments, biasing means such as springs, elastics or pneumatics may be used to urge the guide rollers against the track, and in further embodiments, the tracks may be more triangular shaped at the edges to further facilitate reception of the carriers. If too much correction is required, however, the system may be operating inefficiently.

Systems of the invention therefore provide for binary steering of the automated carrier, allowing only bidirectional column and row travel in a grid. One pivot motor may be used for each pair of wheels, with a linkage to pivot the wheel modules. On other embodiments, one pivot motor and linkage could be used for all four wheels, or each wheel may have an independent pivot actuator. The system allows the wheels to follow square track sections by pivoting around rounded corners of the square track sections. The system does not require differential drive line/trajectory following, and keeps the orientation of the carrier fixed throughout all operations.

Figures 26 and 27 show further embodiments of invention that are based on the above carriers and are provided for movement about a track system as discussed above. For example, Figure 26 shows a carrier 142 in accordance with another embodiment of the present invention that includes swivel mounted wheel assemblies and is operable on a track system as discussed above, but also includes a conveyor 143 that is mounted on the carrier 142, and is actuatable to move a bin or box on the carrier in either of opposing directions as indicated at J . When the carrier 142 is moved to be positioned adjacent a diverting device (such as a diverting chute or conveyor as shown at 144), the carrier may actuate the conveyor 143 to move the bin into the

diverting device 144. The diverting device 144 may for example, but not limiting, be a belt conveyor, a roller conveyor, a chain conveyor, a chute, another bin or a hopper.

Figure 27 shows a carrier 146 in accordance with further embodiment of the present invention that includes swivel mounted wheel assemblies that run along track sections as discussed above, but also includes a tilt tray 147 that is mounted on the carrier base 148, and is actuatable to move a bin in a direction as indicated at *K*. Similarly, when the carrier 146 is moved to be positioned adjacent a diverting device (such as a diverting conveyor as shown at 149), the carrier may actuate the tilt tray 147 to move the bin onto the diverting conveyor 149. The diverting conveyor 149 may for example, but not limiting, be a belt conveyor, a roller conveyor, a chain conveyor, a chute, another bin or a hopper.

The system of an embodiment may also employ motion planning using a trajectory database that is dynamically updated over time, and is indexed by customer metrics. The problem domains contain a mix of changing and unchanging components in the environment. For example, the objects that are presented to the system are often presented in random configurations, but the target locations into which the objects are to be placed are often fixed and do not change over the entire operation.

One use of the trajectory database is to exploit the unchanging parts of the environment by pre-computing and saving into a database trajectories that efficiently and robustly move the system through these spaces. Another use of the trajectory database is to constantly improve the performance of the system over the lifetime of its operation. The database communicates with a planning server that is continuously planning trajectories from the various starts to the various goals, to have a large and varied set of trajectories for achieving any particular task. In various embodiments, a trajectory path may include any number of changing and unchanging portions that, when combined, provide an optimal trajectory path in an efficient amount of time.

Figure 26 for example, shows a diagrammatic view of a system in accordance with an embodiment of the invention that includes an input area conveyor 38 (moving in a direction as indicated at A) that provide input bins 32 to a programmable motion device (as shown diagrammatically at 40), such as an articulated arm, having a base as shown at 59, and an end effector (shown diagrammatically at 94) that is programmed to have a home position (shown at 95), and is programmed for moving objects from an input bin 32 to processing locations, e.g., destination locations at the plurality of carriers 46. Again, the system may include a defined home or base location 95 to which each object may initially be brought upon acquisition from the bin 32. The system also includes a plurality of destination carriers 46 on a track 60.

In certain embodiments, the system may include a plurality of base locations, as well as a plurality of predetermined path portions associated with the plurality of base locations. The trajectories taken by the articulated arm of the robot system from the input bin to the base location are constantly changing based in part, on the location of each object in the input bin, the orientation of the object in the input bin, and the shape, weight and other physical properties of the object to be acquired.

Once the articulated arm has acquired an object and is positioned at the base location, the paths to each of the plurality of destination carriers 46 are not changing. In particular, each destination bin is associated with a unique destination bin location, and the trajectories from the base location to each of the destination bin locations individually is not changing. A trajectory, for example, may be a specification for the motion of a programmable motion device over time. In accordance with various embodiments, such trajectories may be generated by experience, by a person training the system, and/or by automated algorithms. For a trajectory that is not changing, the shortest distance is a direct path to the target destination bin, but the articulated arm is comprised of articulated sections, joints, motors etc. that provide specific

ranges of motion, speeds, accelerations and decelerations. Because of this, the robotic system may take any of a variety of trajectories between, for example, base locations and destination bin locations.

Figure 27 for example, shows three such trajectories (${}_1T^1$, ${}_2T^1$ and ${}_3T^1$) between base location 95 and a destination bin location 102. The elements of Figure 27 are the same as those of Figure 26. Each trajectory will have an associated time as well as an associated risk factor. The time is the time it takes for the articulated arm of the robotic system to accelerate from the base location 95 move toward the destination bin 102, and decelerate to the destination bin location 106 in order to place the object in the destination bin 102.

The risk factor may be determined in a number of ways including whether the trajectory includes a high (as pre-defined) acceleration or deceleration (linear or angular) at any point during the trajectory. The risk factor may also include any likelihood that the articulated arm may encounter (crash into) anything in the robotic environment. Further, the risk factor may also be defined based on learned knowledge information from experience of the same type of robotic arms in other robotic systems moving the same object from a base location to the same destination location.

As shown in the table at 96 in Figure 27, the trajectory ${}_1T^1$ from the base location 95 to the destination location 102 may have a fast time (0.6s) but a high risk factor. The trajectory ${}_2T^1$ from the base location 95 to the destination location 102 may have a much slower time (1.4s) but still a fairly high risk factor (16.7). The trajectory ${}_3T^1$ from the base location 95 to the destination location 102 may have a relatively fast time (1.3s) and a moderate risk factor (11.2). The choice of selecting the fastest trajectory is not always the best as sometimes the fastest trajectory may have an unacceptably high risk factor. If the risk factor is too high, valuable time may be lost by failure of the robotic system to maintain acquisition of the object.

Different trajectories therefore, may have different times and risk factors, and this data may be used by the system in motion planning.

Figure 28, for example, shows minimum time-selected trajectories from the base location 95 to each of destination bin locations 102 - 118. In particular, the tables shown at 97 that the time and risk factors for a plurality of the destination bins, and the trajectories from the base location 95 to each of a plurality of the destination bin locations are chosen to provide the minimum time for motion planning for motion planning under a risk factor of 14.0.

Figure 29 shows minimum risk-factor-selected set of trajectories from the base location 95 to each of the destination bin locations 102 – 118. Again, the tables shown at 97 show the time and risk factors for the plurality of the destination bins (e.g., 1 – 3). The trajectories from the base location 95 to each of the destination bin locations 102 – 118 are chosen to provide the minimum risk factor for motion planning for motion planning under a maximum time of 1.2 seconds.

The choice of fast time vs. low risk factor may be determined in a variety of ways, for example, by choosing the fastest time having a risk factor below an upper risk factor limit (e.g., 12 or 14), or by choosing a lowest risk factor having a maximum time below an upper limit (e.g., 1.0 or 1.2). Again, if the risk factor is too high, valuable time may be lost by failure of the robotic system to maintain acquisition of the object. An advantage of the varied set is robustness to small changes in the environment and to different-sized objects the system might be handling: instead of re-planning in these situations, the system iterates through the database until it finds a trajectory that is collision-free, safe and robust for the new situation. The system may therefore generalize across a variety of environments without having to re-plan the motions.

Overall trajectories therefore, may include any number of changing and unchanging sections. For example. networks of unchanging trajectory portions may be employed as

commonly used paths (roads), while changing portions may be directed to moving objects to a close-by unchanging portion (close road) to facilitate moving the object without requiring the entire route to be planned. For example, the programmable motion device (e.g., a robot) may be tasked with orienting the grasped object in front of an automatic labeler before moving towards the destination. The trajectory to sort the object therefore, would be made up of the following trajectory portions. First, a grasp pose to a home position (motion planned). Then, from home position to an auto-labeler home (pulled from a trajectory database). Then, from the auto-labeler home to a labelling pose (motion planned). Then, from the labelling pose to an auto-labeler home (either motion planned or just reverse the previous motion plan step). Then, from the auto-labeler home to the intended destination (pulled from the trajectory database). A wide variety of changing and unchanging (planned and pulled from a database) portions may be employed in overall trajectories. In accordance with further embodiments, the object may be grasped from a specific pose (planned), and when the object reaches a destination bin (from the trajectory database), the last step may be to again place the object in the desired pose (planned) within the destination bin.

In accordance with further embodiments, the motion planning may also provide that relatively heavy items (as may be determined by knowing information about the grasped object or by sensing weight – or both – at the end effector) may be processed (e.g., moved in trajectories) and placed in boxes in very different ways than the processing and placement of relatively light objects. Again, the risk verses speed calculations may be employed for optimization of moving known objects of a variety of weights and sizes as may occur, for example, in the processing of a wide variety of consumer products. The system, therefore, provides means that interface with the customer's outgoing object conveyance systems. When a bin (or package) is full as determined by the system (in monitoring system operation), a human operator may pull the bin from the processing area, and place the bin in an appropriate

conveyor. When a bin is full gets removed to the closed / labelled, another empty bin is immediately placed in the location freed up by the removed full bin, and the system continues processing as discussed above.

The assignment of carriers may also be dynamic since any carrier may dynamically be assigned to service any package below the track. For example, systems in accordance with further embodiments, provide improved transport and conveyor systems, and provide programmable diverters, in particular, that allow dynamically changing patterns of object handling, with resulting efficiencies in the sortation or processing of objects, and lower space requirements, lower demand for manual operations, and as a consequence, lower capital and operating costs for the entire system.

During use, for example and in accordance with certain embodiments, the system may identify an object by the perception system, and then dynamically assign a destination location (carrier 46) to the object. The process is still governed by the overall manifest, but the assignment of destination bins may be dynamic, based on a variety of heuristic, such as the likelihood of receiving objects for the same designation (e.g., if the likelihood is high, the destination location may be assigned to be close to the home position of the carriage in order to save time), as well as whether to assign a second destination bin to an object (e.g., if the likelihood of receiving objects for the same destination is very high).

The system therefore assigns a bin to an object if a new bin is available, and the object is not yet assigned a bin at the sorting station. What is significant, is that the sorting station is not pre-assigned a large set of collection bins assigned to all possible objects that may appear in the input path. If a bin is not assigned to an object, yet no new bin is available for a new assignment, the object may be returned to the input hopper until it is processed at a time that a new bin becomes available. Further, the central controller may employ wide variety of heuristics that may further shape the process of dynamically assigning objects to collection

bins as discussed in yet further detail below. Once bins are either filled or otherwise completed, the completed bins are signaled as being done and ready for further processing.

With reference to Figure 30, in many processing systems, a fixed relationship may exist between an object 151 and a destination 155 is a fixed relationship. In conventional sortation systems, an intermediate container 153 is assigned a fixed relationship with the destination, and this relationship dictates the assignment of the object 151 to the intermediate container 153. This is shown in Figure 32, where each destination 164, 166, 168, 170, 172 is associated with an intermediate container 154, 156, 158, 160, 162. As objects 152 are processed, they are simply routed to the appropriate intermediate containers as directed by the fixed relationship.

In accordance with embodiments of the present invention on the other hand, the relationships between intermediate containers and destinations is not fixed, and changes dynamically during sortation. Figure 31, for example, shows that while the relationship between an object 157 and its destination 161 is fixed, the assignment of an intermediate container 159 (e.g., a collection bin), is dynamically chosen based on a variety of heuristics. Once assigned, it remains in place until the collection bin is emptied. As shown in Figure 31, the assignment of a collection bin (intermediate container 153) for an object 157 is determined by the object destination and the intermediate container to destination mapping, and the destination mapping (between the intermediate container 153 and the destination 161) is re-assigned dynamically during operation.

With reference to Figure 33A, at the beginning of a sortation process, there may be no assigned relationships between intermediate containers 176, 178, 180, 182, 184 and objects 174, or between intermediate containers 176, 178, 180, 182, 184 and destinations 186, 188, 190, 192, 194. As shown in Figure 33B, when an object's indicia is detected, an intermediate container 176 is assigned to the object, and the object's destination 188 is assigned to the intermediate container as well. Additional objects that are processed and are also associated

with the destination 188 are also provided in intermediate container 176. With reference to Figure 33C, when a different object's indicia is detected that is associated with a different destination 192, a new intermediate container 178 is assigned to the object, and the object's destination 192 is assigned to the intermediate container as well. As noted above, when an object is selected that is associated with a destination, e.g., 188, that already has an intermediate container 176 associated with it, the object may be placed in the same intermediate container 176 (see Figure 33D). In accordance with certain embodiments of the invention however, and with reference to Figure 33E, the system may elect to assign a new intermediate container 180 to the destination 188, for example, if it is known that many of the objects are likely to be associated with the destination 188. With reference to Figure 33F, when another object's indicia is detected that is associated with another destination 186, a new intermediate container 184 is assigned to the object, and the object's destination 186 is assigned to the intermediate container 184.

When an intermediate container becomes full or is determined to be otherwise ready for further processing (e.g., if the system determines that it is unlikely to see another object associated with the destination), the intermediate container is emptied and the contents are forward for further processing. For example, and with reference to Figure 33G, when the system determines that intermediate container 176 is full, the contents are emptied, and the intermediate container 176 is then again unassigned to a destination as shown in Figure 33H. The intermediate container 176 may then later be reused and associated with a new destination 190 as shown in Figure 33I.

As shown in Figure 34, a sortation process of the invention at a sorting station may begin (step 200) and the articulated arm, or another programmable motion device, receives a new object (step 202). The system identifies the new object (step 204) by an overhead scanner or other scanner system. The system then determines whether any location at the station has

yet been assigned to the new object (step 206). If so, the system the places the object at that location (step 218). If not, the system then determines whether a next location is available (Step 208). If not, the system may (either with or without input from a human) determine whether to retry identifying the object (step 210). If so, then the system would return the object to the input stream (step 212) to be again received at a later time (step 202). If not, the system would place the object in a manual sorting area for sortation by a human (step 214). If a next location is available (step 208), the system the assigns a next location to the object (step 216), and the object is then placed in that location (step 218). If a location had already been assigned to the object (step 206), the system the object is placed in that location (step 218). The number of objects at the location is then updated (step 220), and if the location is then full (step 222), the system identifies that the location is ready for further processing (step 226). If not, the system then determines whether (based on prior knowledge and/or heuristics), whether the location is likely to receive a further object (step 224). If so, the system identifies that the location is ready for further processing (step 226). If not, the system returns to receiving a new object (step 202). The further processing may, for example include collecting the items at the location in a single bag for transport to a shipping location.

In accordance with a specific embodiment, the invention provides a user interface that conveys all relevant information to operators, management, and maintenance personnel. In a specific embodiment, this may include lights indicating bins that are about to be ejected (as full), bins that are not completely properly positioned, the in-feed hopper content level, and the overall operating mode of the entire system. Additional information might include the rate of object processing and additional statistics. In a specific embodiment, the system may automatically print labels and scan labels before the operator places the packages on an output conveyor. In accordance with a further embodiment, the system may incorporate software systems that interface with the customer's databases and other information systems, to provide

operational information to the customer's system, and to query the customer's system for object information.

A process of the overall control system is shown, for example, in Figure 35. The overall control system may begin (step 300) by permitting a new collection bin at each station to be assigned to a group of objects based on overall system parameters (step 302) as discussed in more detail below. The system then identifies assigned bins correlated with objects at each station (step 304), and updates the number of objects at each bin at each station (step 306). The system then determines that when a bin is either full or the system expects that the associated sorting station is unlikely to see another object associated with the bin, the associated sorting station robotic system will then place the completed bin onto an output conveyor, or signal a human worker to come and empty the bin (step 308), and then return to step 302.

Systems of various embodiments provide numerous advantages because of the inherent dynamic flexibility. The flexible correspondence between sorter outputs and destinations provides that there may be fewer sorter outputs than destinations, so the entire system may require less space. The flexible correspondence between sorter outputs and destinations also provides that the system may choose the most efficient order in which to handle objects, in a way that varies with the particular mix of objects and downstream demand. The system is also easily scalable, by adding sorters, and more robust since the failure of a single sorter might be handled dynamically without even stopping the system. It should be possible for sorters to exercise discretion in the order of objects, favoring objects that need to be handled quickly, or favoring objects for which the given sorter may have a specialized gripper.

Those skilled in the art will appreciate that numerous modifications and variations may be made to the above disclosed embodiments without departing from the spirit and scope of the present invention.

What is claimed is:

CLAIMS

1. A processing system for processing objects using a programmable motion device, said processing system comprising:

a perception unit for perceiving identifying indicia representative of an identity of a plurality of objects received from an input conveyance system;

an acquisition system for acquiring an object from the plurality of objects at an input area using an end effector of the programmable motion device, wherein the programmable motion device is adapted for assisting in the delivery of the object to an identified processing location, said identified processing location being associated with the identifying indicia and said identified processing location being provided as one of a plurality of processing locations; and

a delivery system for receiving the object in a carrier and for delivering the object toward the identified processing location.

2. The processing system as claimed in claim 1, wherein the input conveyance system includes a primary conveyor and an input area conveyor onto which the plurality of objects may be diverted from the primary conveyor.

3. The processing system as claimed in claim 1, wherein the plurality of objects is provided in a bin that is one of a plurality of bins, each including a further plurality of objects.

4. The processing system as claimed in claim 1, wherein the carrier is movable in at least two dimensions.

5. The processing system as claimed in claim 1, wherein the carrier is adapted for delivering the object toward the identified processing location by dropping the object into the identified processing location.
6. The processing system as claimed in claim 5, wherein the carrier is adapted for delivering the object toward the identified processing location by dropping the object into the identified processing location by dropping the object through the bottom of the carrier.
7. The processing system as claimed in claim 1, wherein a subset of processing locations is provided on a pull-out drawer.
8. The processing system as claimed in claim 1, wherein the acquisition system is adapted to cause the object to be delivered toward the identified processing location by placing the object into the carrier using the end effector.
9. The processing system as claimed in claim 1, wherein each processing location includes a processing bin.
10. The processing system as claimed in claim 9, wherein the processing system further includes an output conveyor onto which each processing bin may be placed.
11. The processing system as claimed in claim 1, wherein the processing system is provided as one of a plurality of processing systems that are each in communication with the input conveyance system.

12. A processing system for processing objects using a programmable motion device, said processing system comprising:

a perception unit for perceiving identifying indicia representative of an identity of a plurality of objects associated with an input conveyance system;

an acquisition system for acquiring an object from the plurality of objects at an input area using an end effector of the programmable motion device, wherein the programmable motion device is adapted for assisting in the delivery of the object to an identified processing location, said identified processing location being associated with the identifying indicia and said identified processing location being provided as one of a plurality of processing locations; and

a delivery system delivering the object to the identified processing location, said delivery system including a plurality of carriers that are individually movable in at least two dimensions, and any of which carriers may contain the object.

13. The processing system as claimed in claim 12, wherein the input conveyance system includes a primary conveyor and an input area conveyor onto which the plurality of objects may be diverted from the primary conveyor.

14. The processing system as claimed in claim 12, wherein the plurality of objects is provided in a bin that is one of a plurality of bins, each including a further plurality of objects.

15. The processing system as claimed in claim 12, wherein the plurality of carriers each move in a common two dimensional coordinate area.

16. The processing system as claimed in claim 15, wherein the processing system includes at least two programmable motion devices, and wherein each of the at least two programmable motion devices is adapted to provide objects to carriers that may each provide objects to a common set of processing locations that extend in at least two dimensions.
17. The processing system as claimed in claim 12, wherein each of the plurality of carriers is adapted for delivering the object toward the identified processing location by dropping the object into one of a plurality of processing locations.
18. The processing system as claimed in claim 12, wherein the acquisition system is adapted for causing the object to be delivered toward the identified processing location by placing the object into the carrier using the end effector.
19. The processing system as claimed in claim 12, wherein the carrier is a cart that is movable in at least two dimensions.
20. The processing system as claimed in claim 19, wherein the cart is one of a plurality of carts that are movable in the at least two dimensions.
21. The processing system as claimed in claim 12, wherein the processing system is provided as one of a plurality of processing systems that are each in communication with the input conveyance system.
22. A method of processing objects using a programmable motion device, said method comprising the steps of:

perceiving identifying indicia representative of an identity of a plurality of objects received from an input conveyance system;

acquiring an object from the plurality of objects at an input area using an end effector of the programmable motion device, wherein the programmable motion device is adapted for assisting in the delivery of the object to an identified processing location, said identified processing location being associated with the identifying indicia and said identified processing location being provided as one of a plurality of processing locations; and

delivering the object toward the identified processing location, said step of delivering the object toward the identified processing location including receiving the object in a carrier.

23. The method as claimed in claim 22, wherein the input conveyance system includes a primary conveyor and an input area conveyor onto which the plurality of objects may be diverted from the primary conveyor.

24. The method as claimed in claim 22, wherein the plurality of objects is provided in a bin that is one of a plurality of bins, each including a further plurality of objects.

25. The processing system as claimed in claim 22, wherein the step of acquiring the object includes planning an optimal grasp of location for the object.

26. The method as claimed in claim 22, wherein the carrier is movable in at least two dimensions.

27. The method as claimed in claim 22, wherein the step of causing the object to be delivered toward the identified processing location includes placing the object into the carrier using the end effector.

28. The method as claimed in claim 22, wherein the step of delivering the object toward the identified processing location includes dropping the object into the identified processing location.

29. The method as claimed in claim 22, wherein the step of causing the object to be delivered toward the identified processing location includes moving the object in each of two mutually orthonogal directions in the carrier.

30. The method as claimed in claim 22, wherein a subset of processing locations are provided on a pull-out drawer.

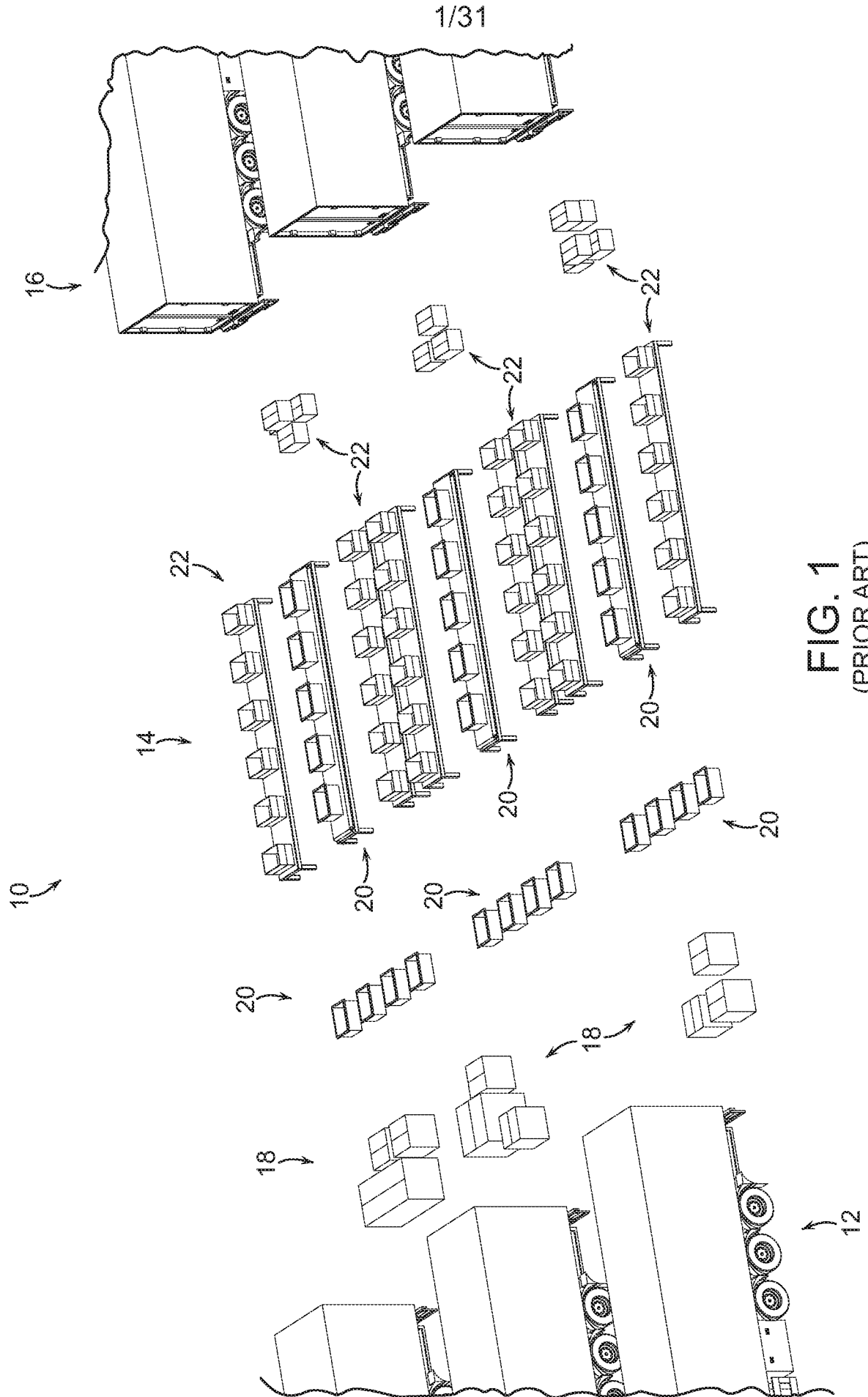

FIG. 1
(PRIOR ART)

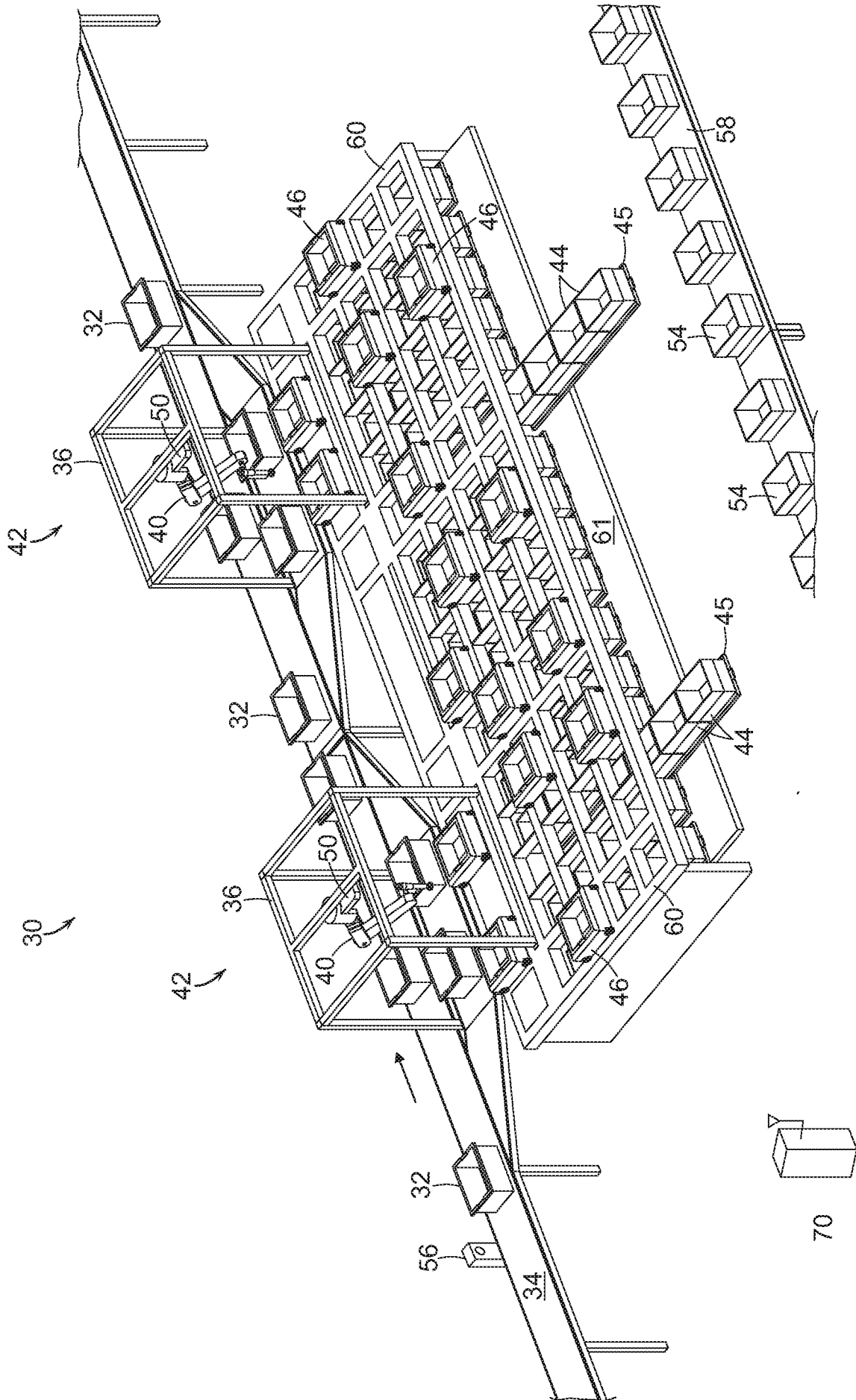

FIG. 2

4/31

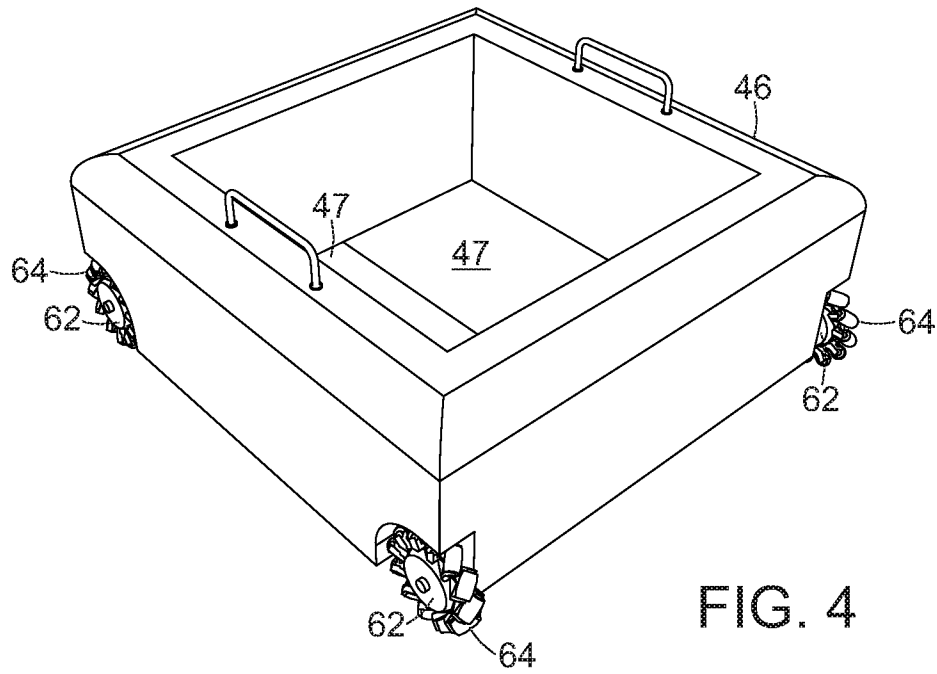

FIG. 4

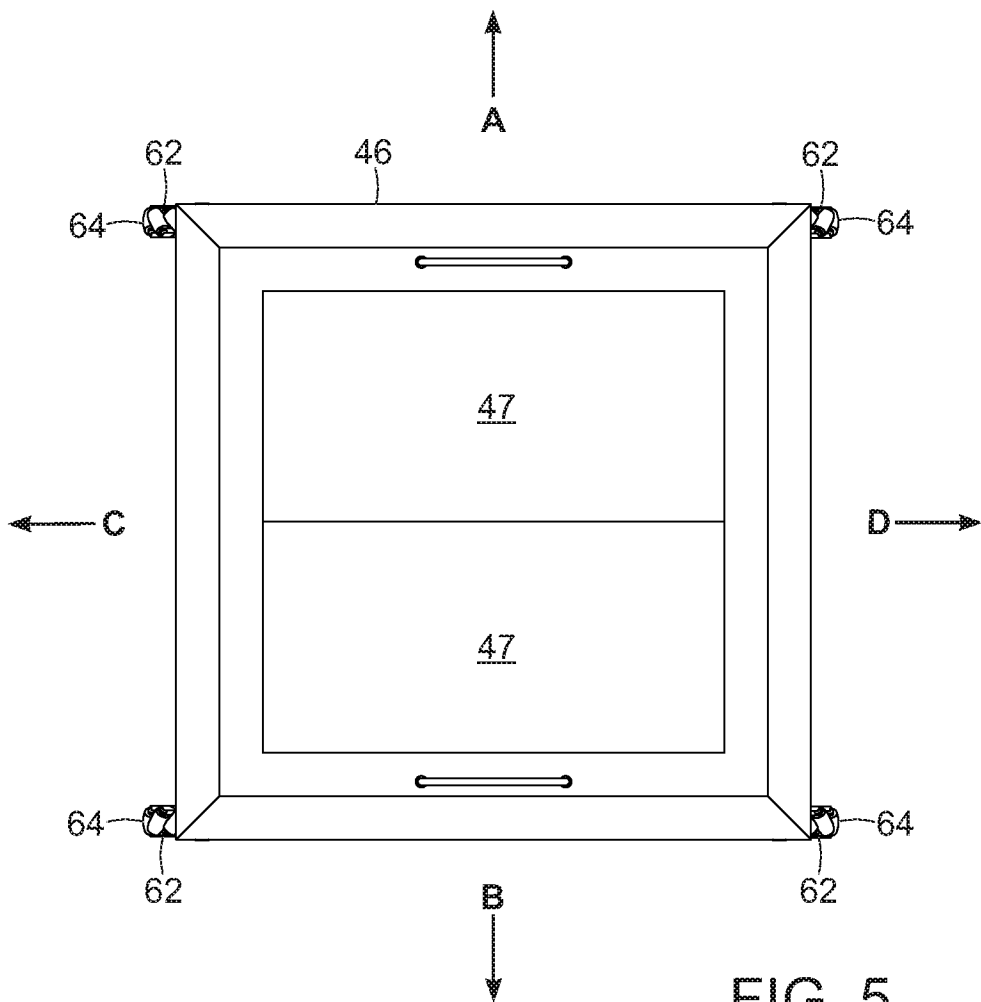

FIG. 5

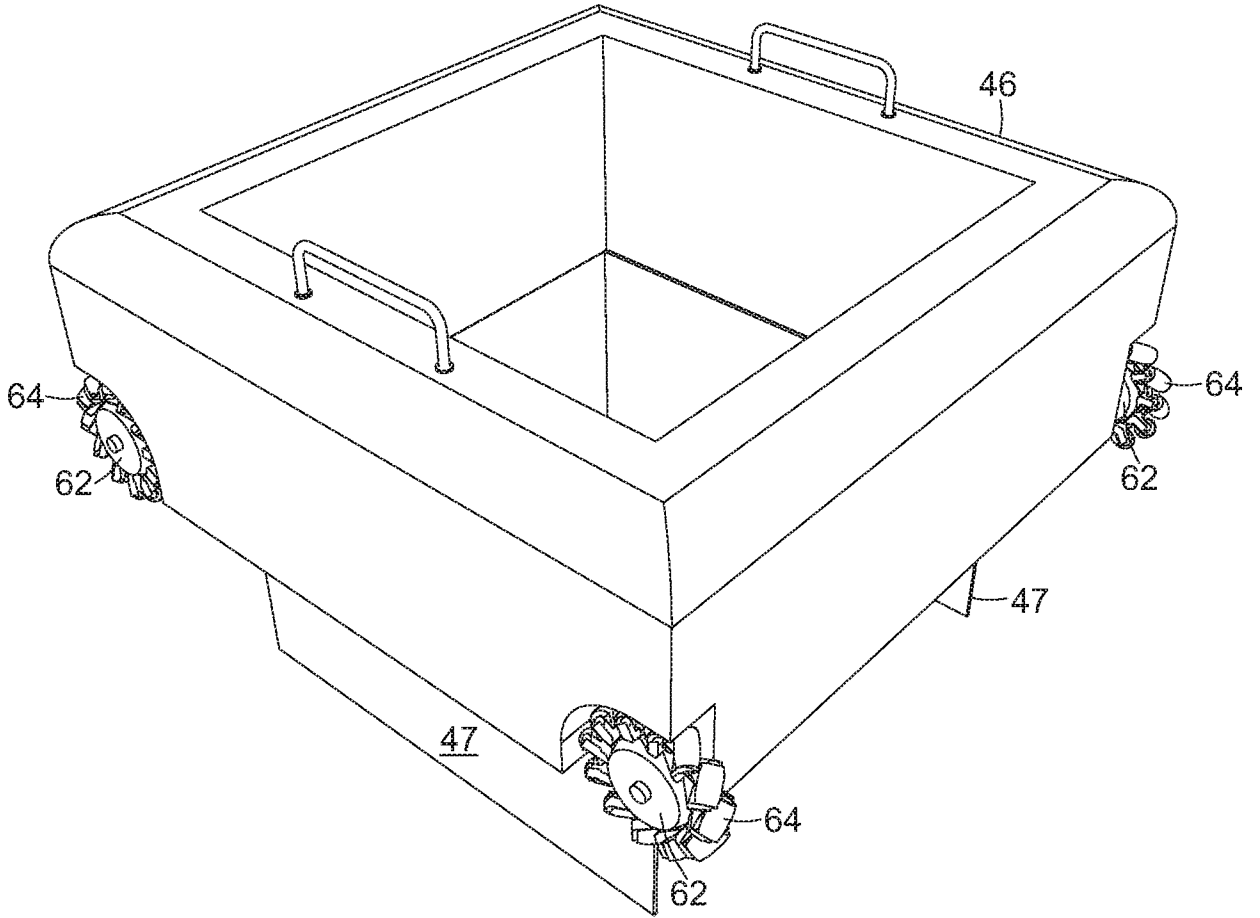

FIG. 6

6/31

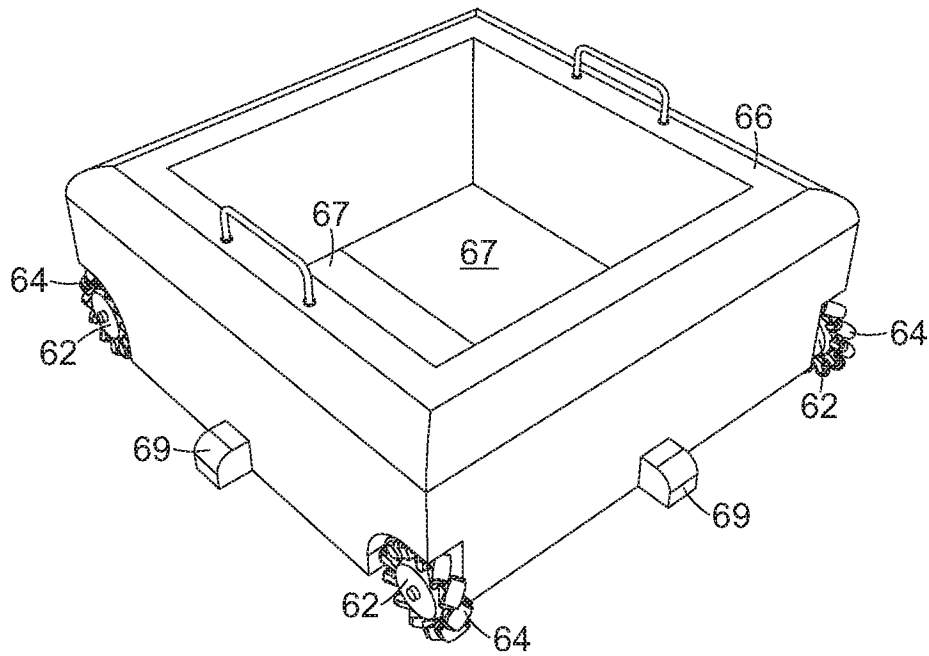

FIG. 7

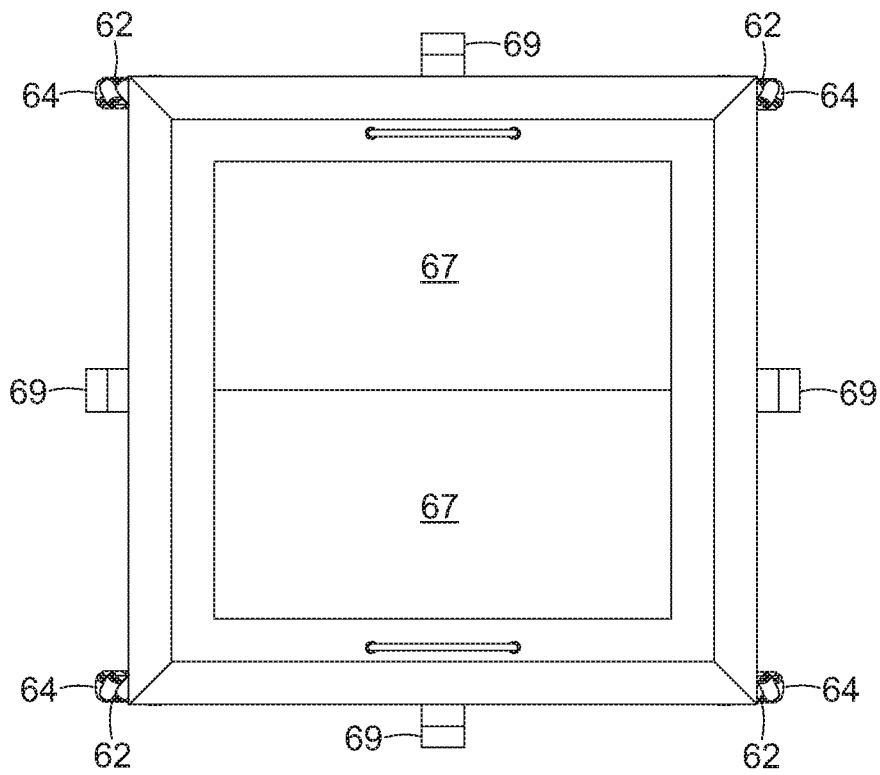

FIG. 8

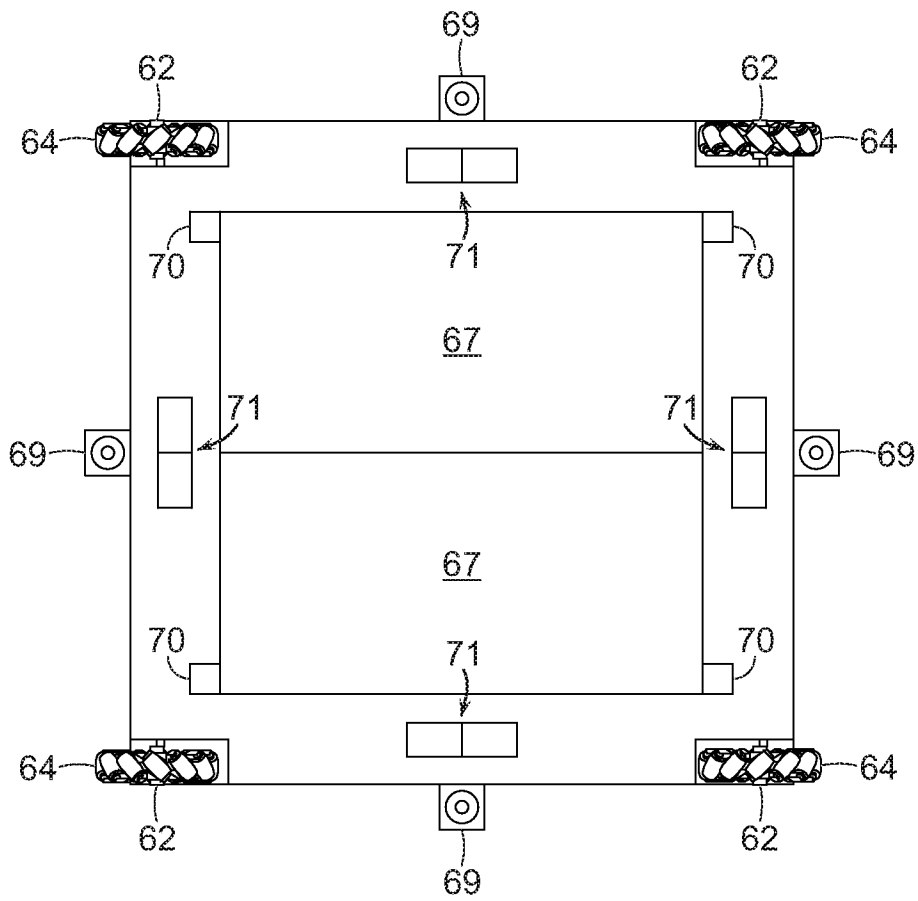

FIG. 9

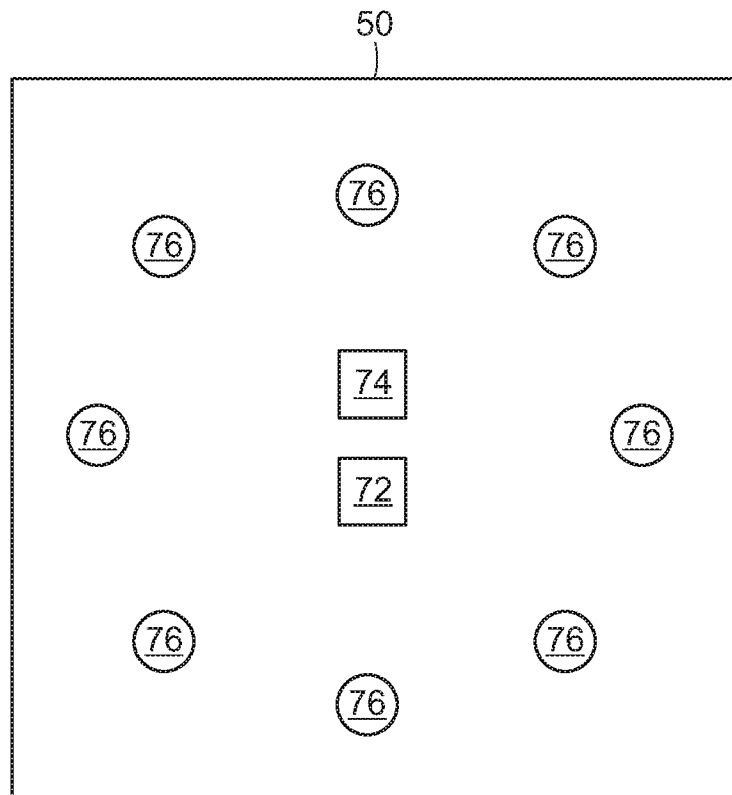

FIG. 10

9/31

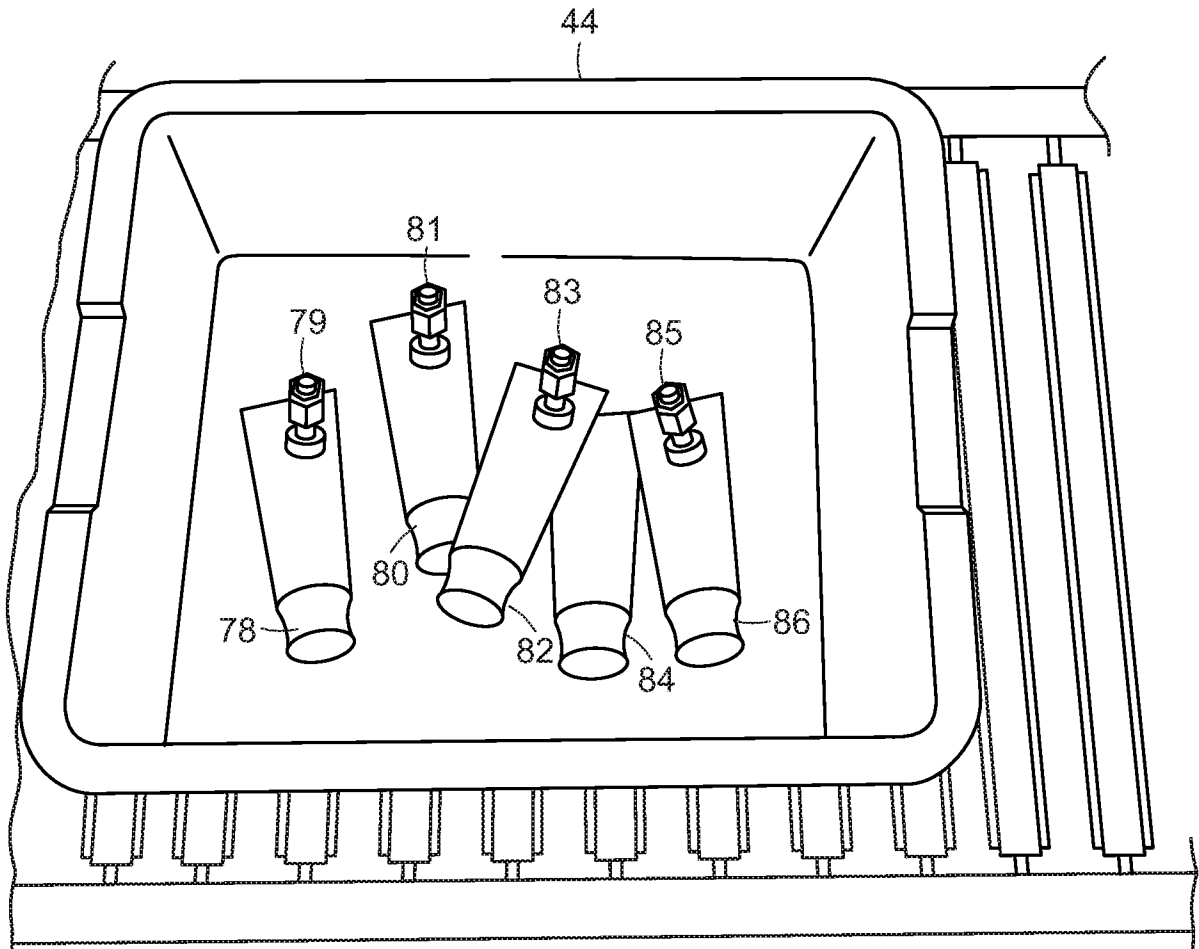

FIG. 11

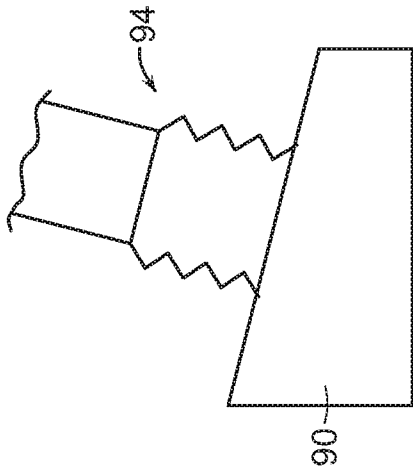

FIG. 14A

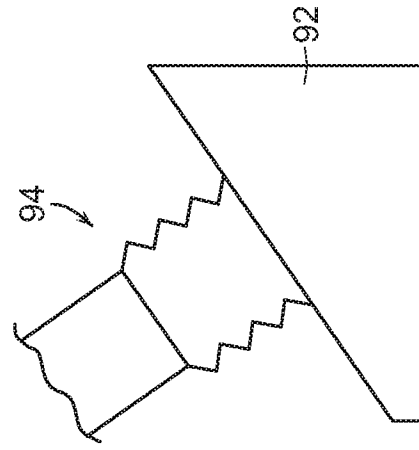

FIG. 14B

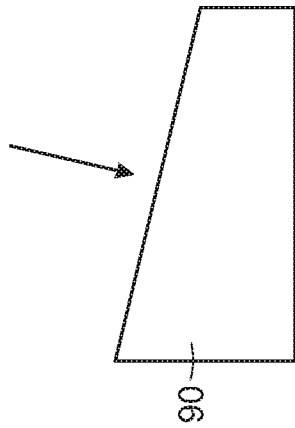

FIG. 13A

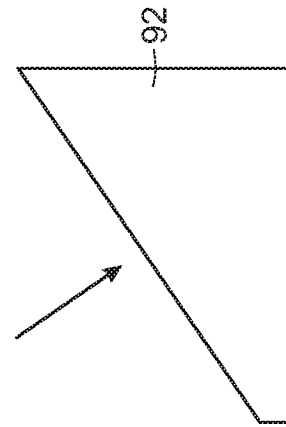

FIG. 13B

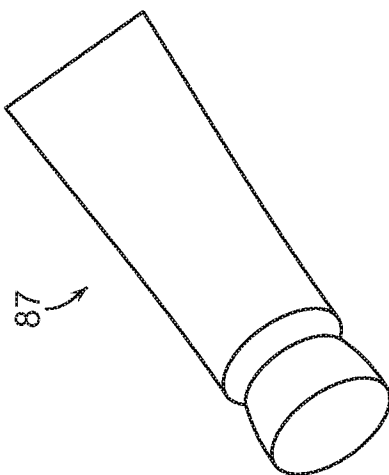

FIG. 12A

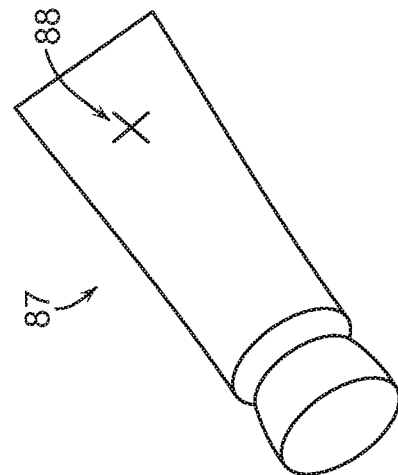

FIG. 12B

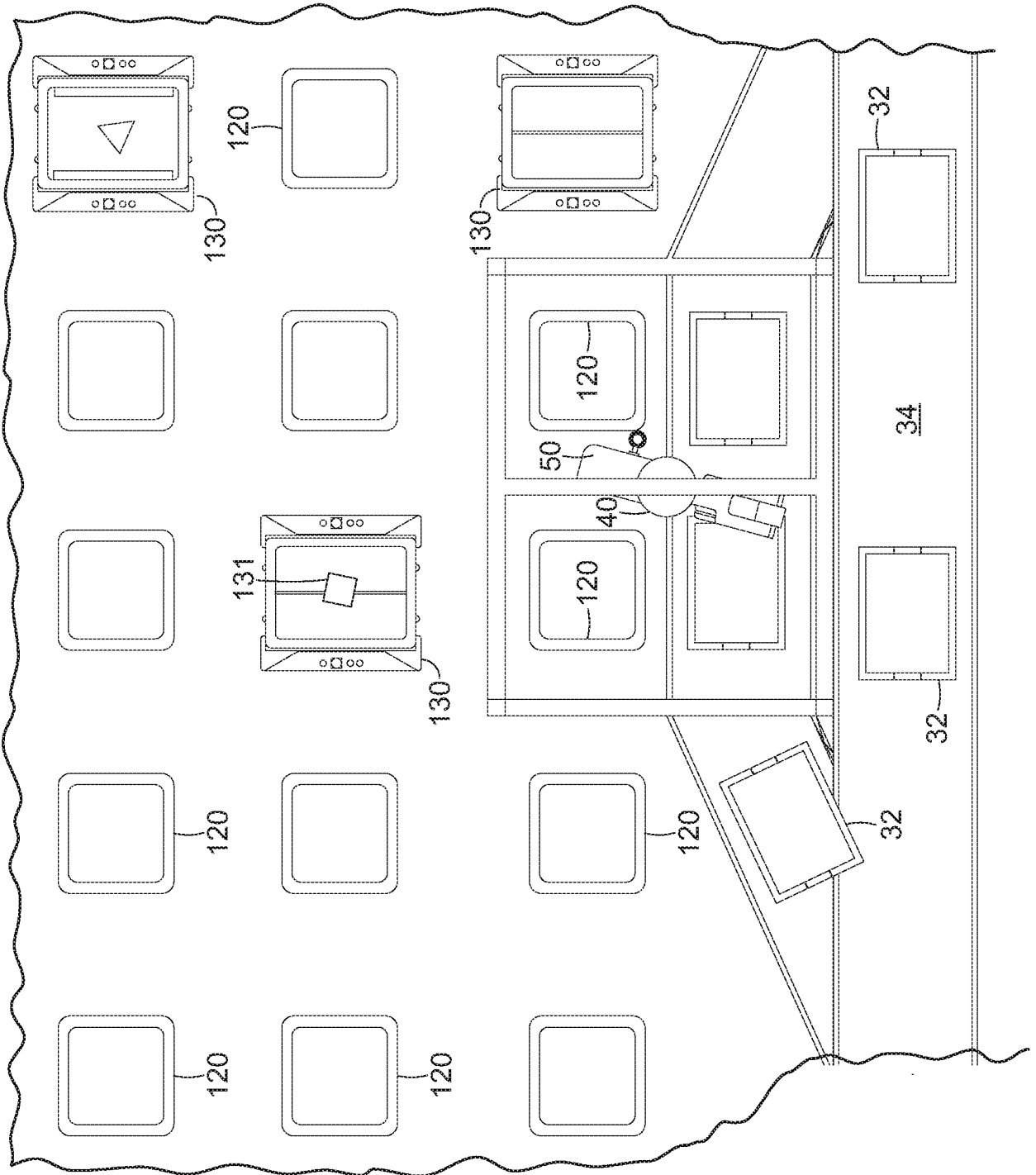

FIG. 15

12/31

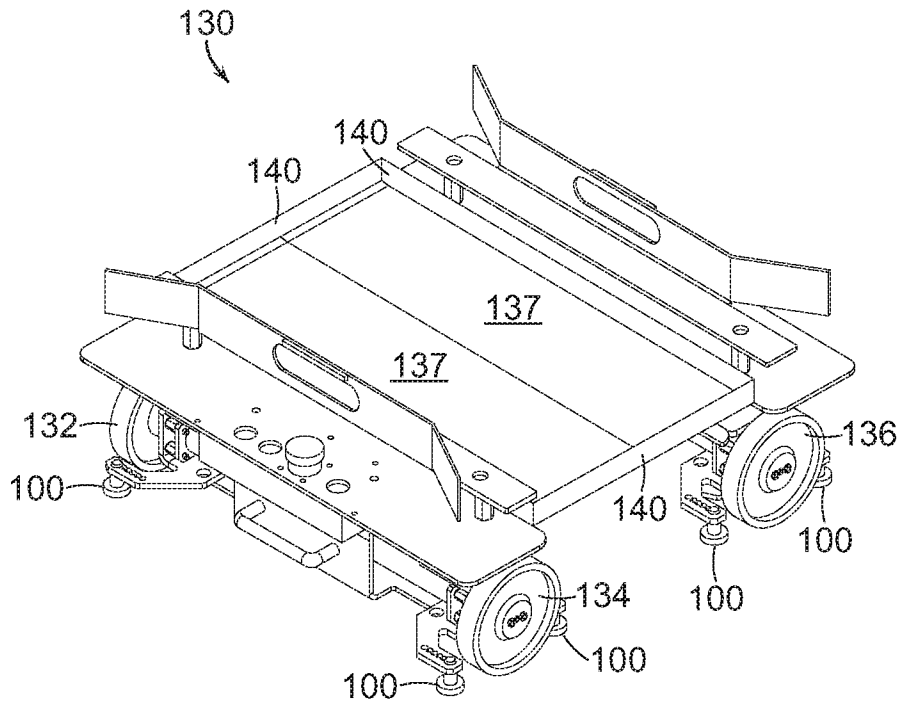

FIG. 16

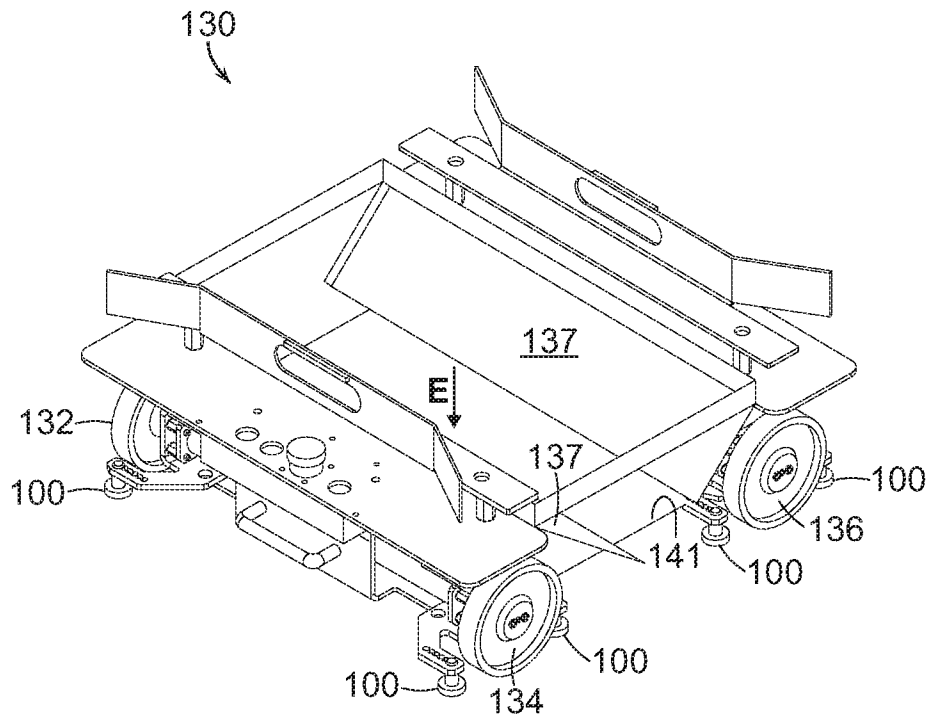
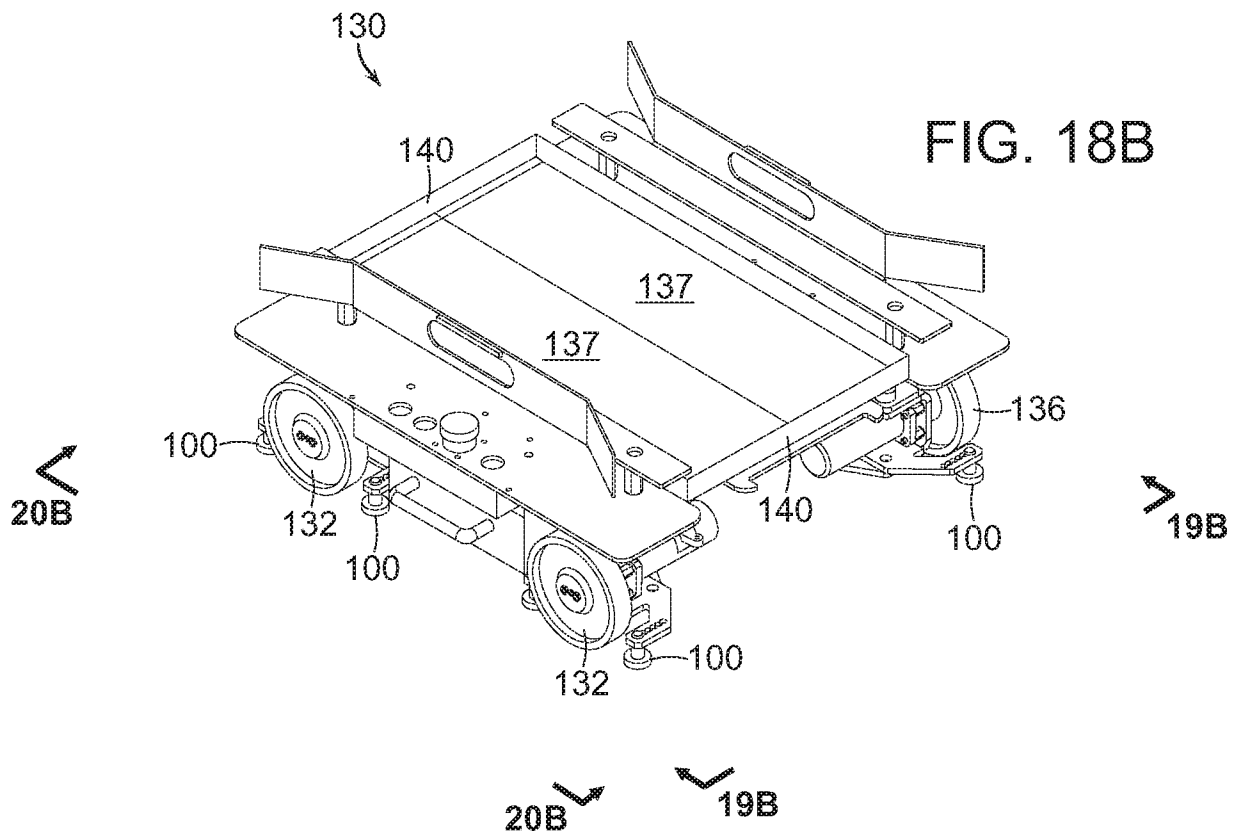
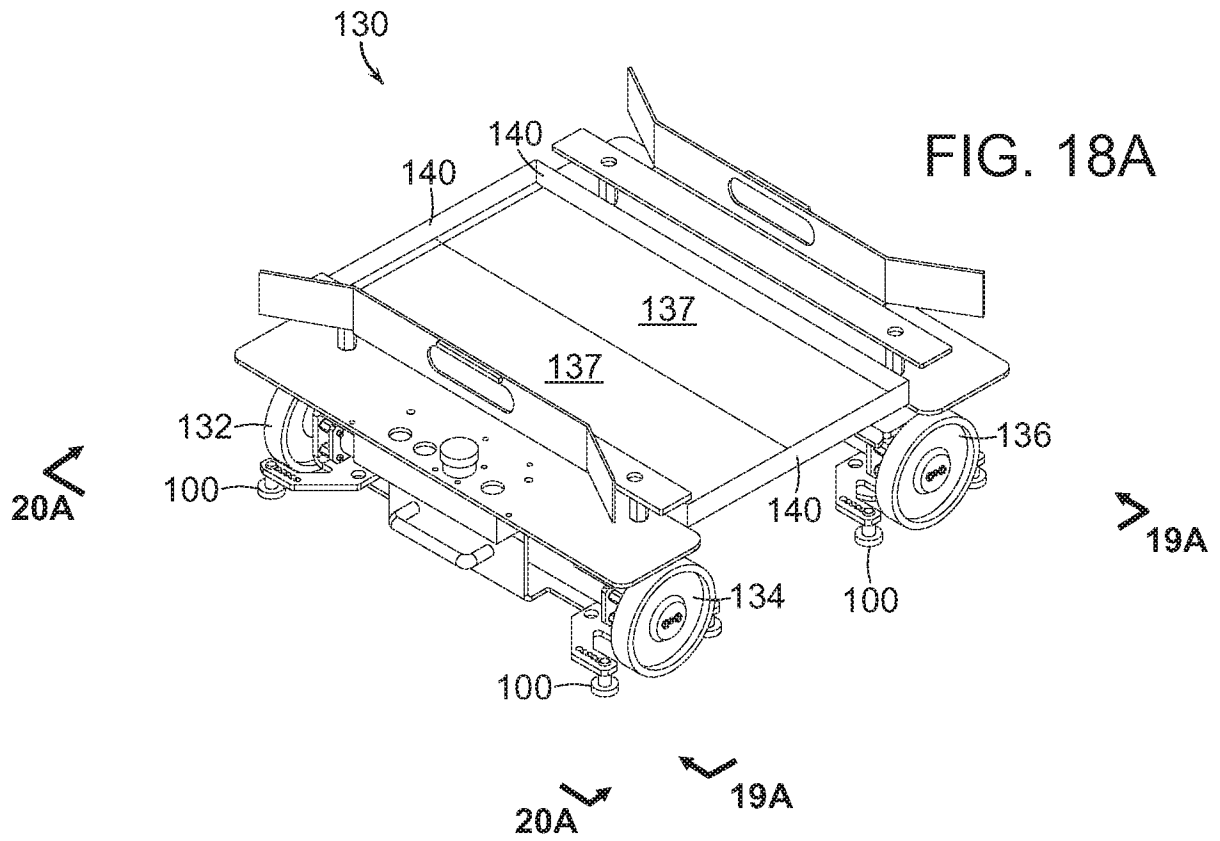

FIG. 17

13/31



14/31

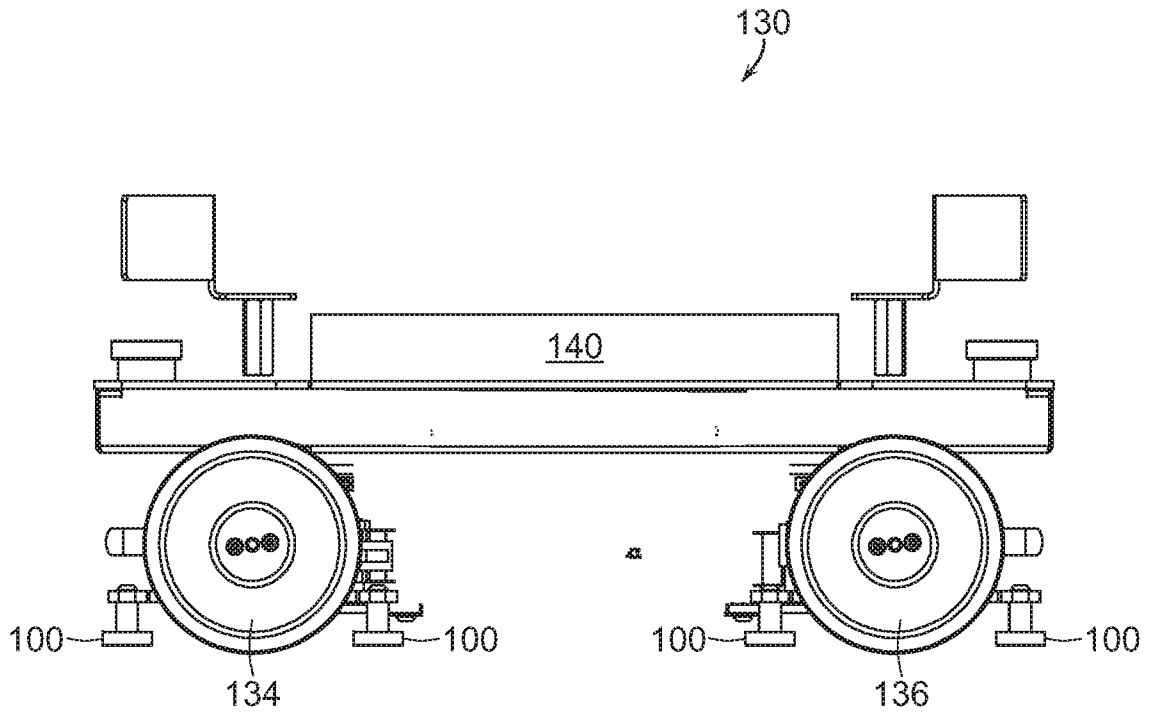

FIG. 19A

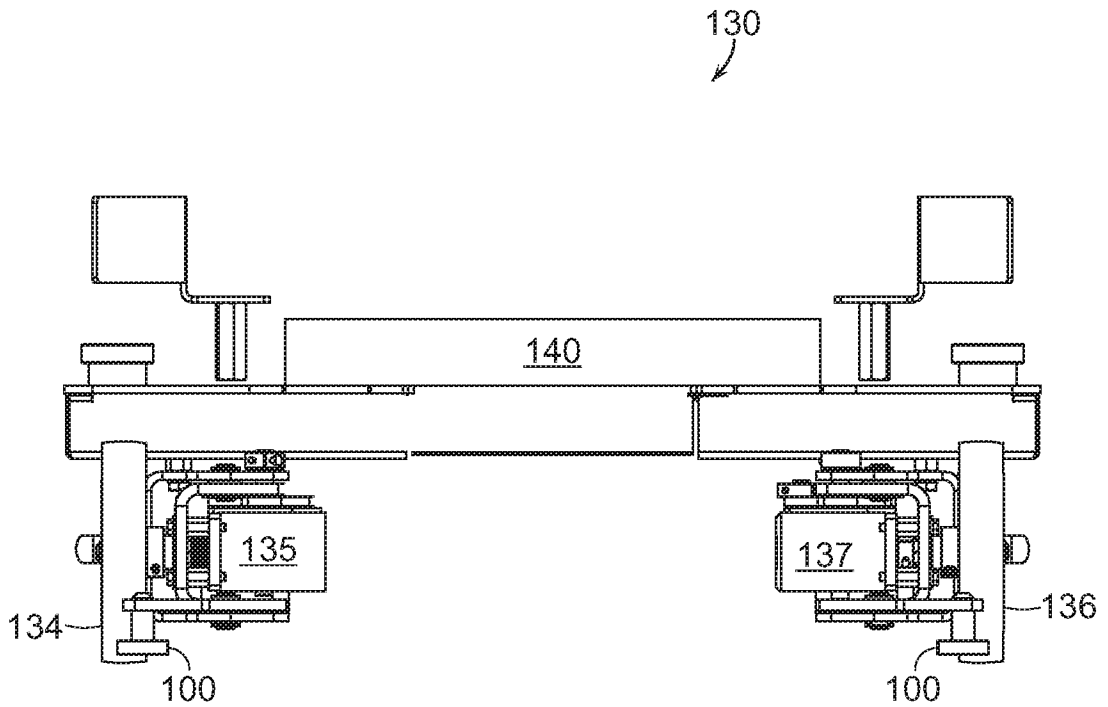

FIG. 19B

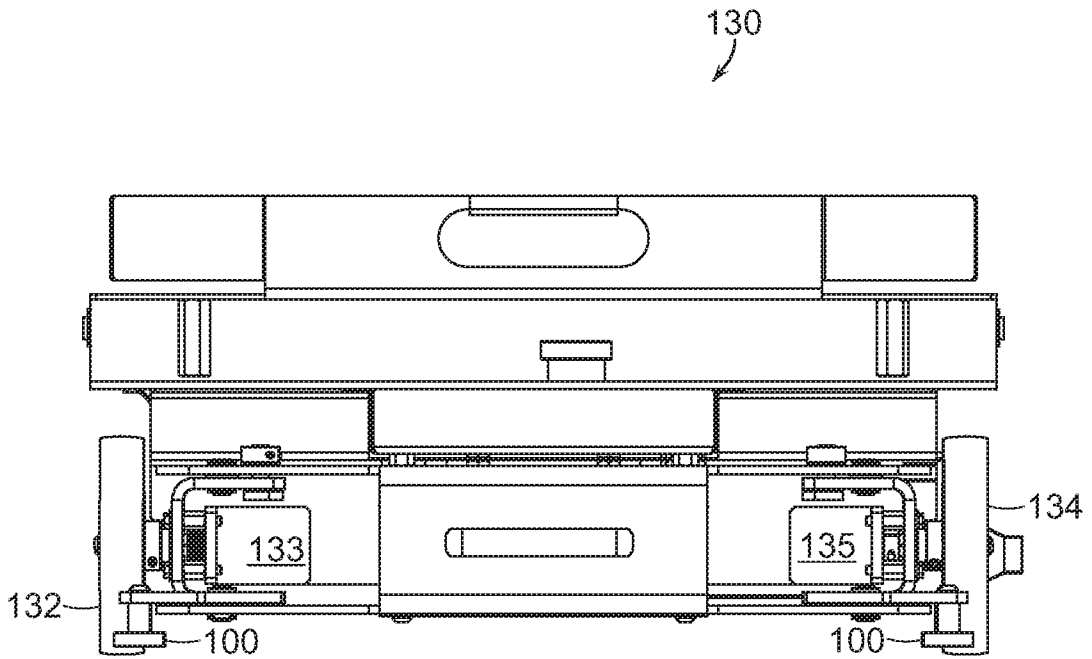

FIG. 20A

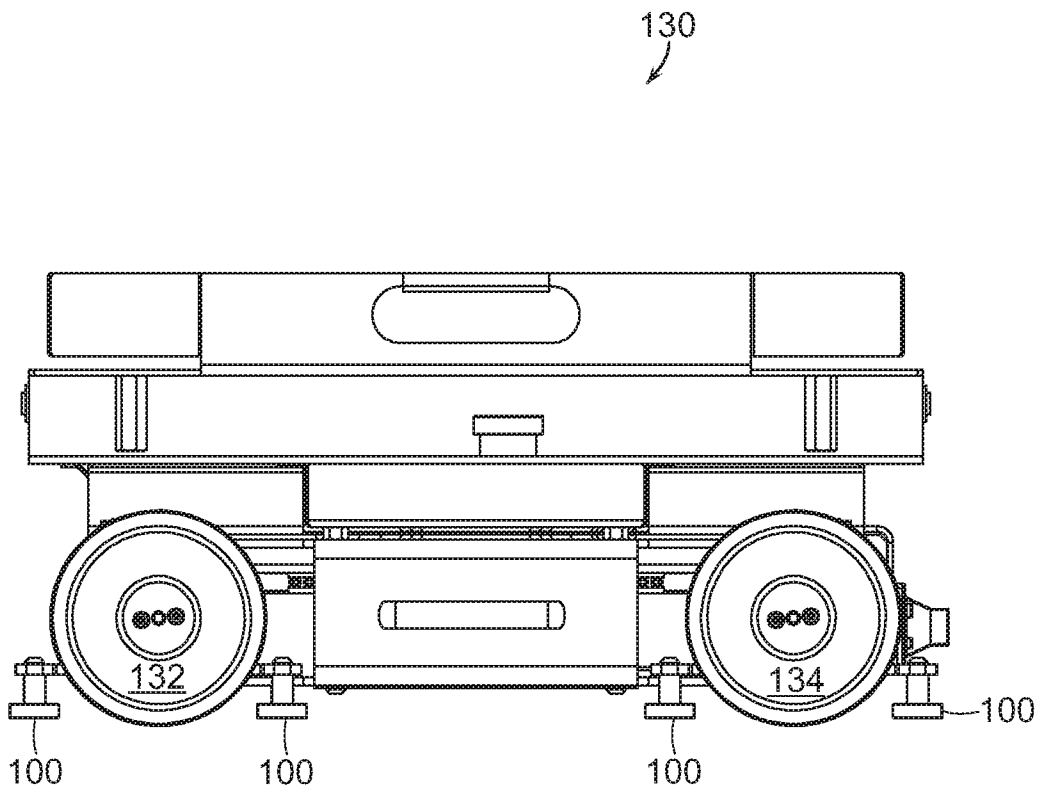

FIG. 20B

16/31

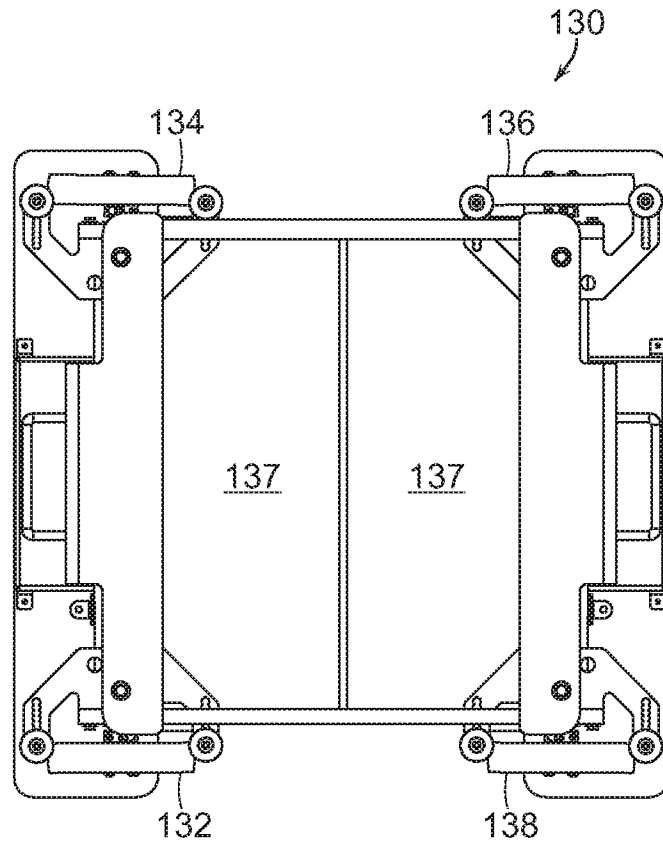

FIG. 21A

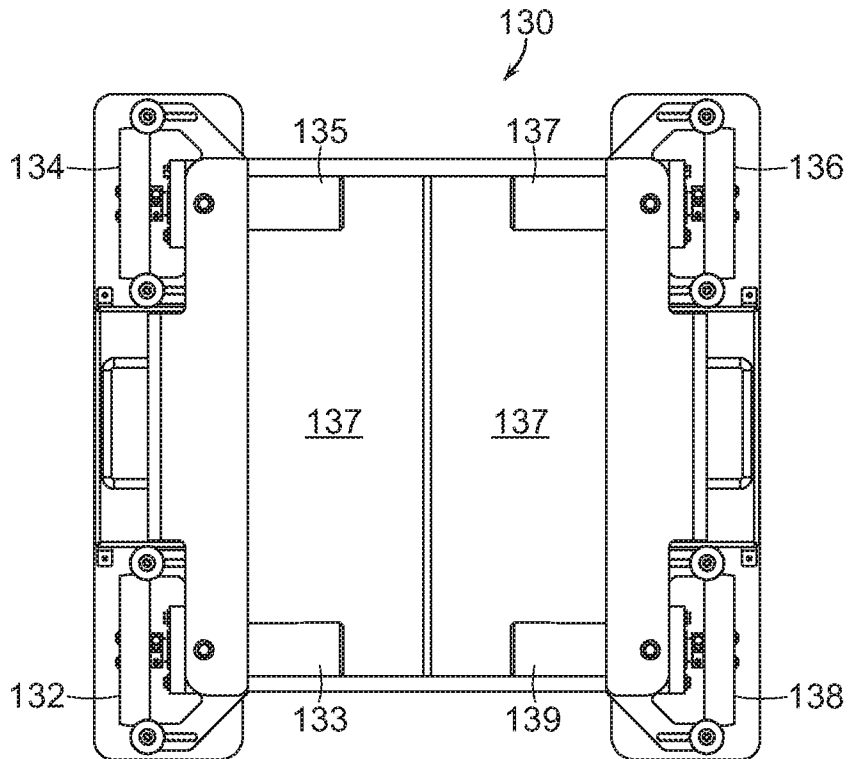
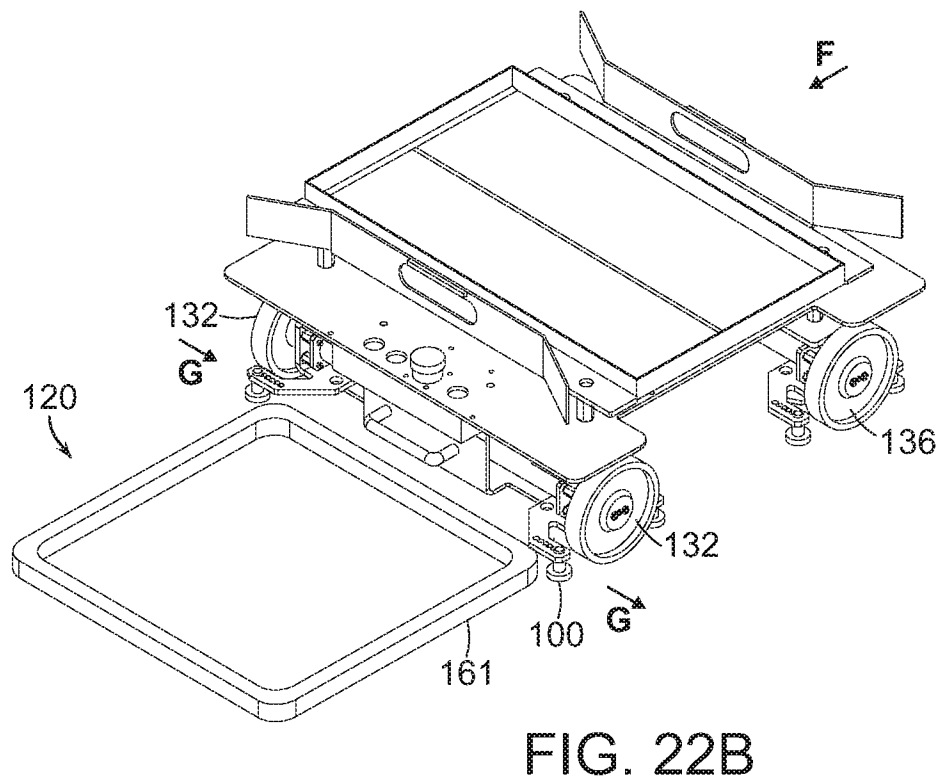
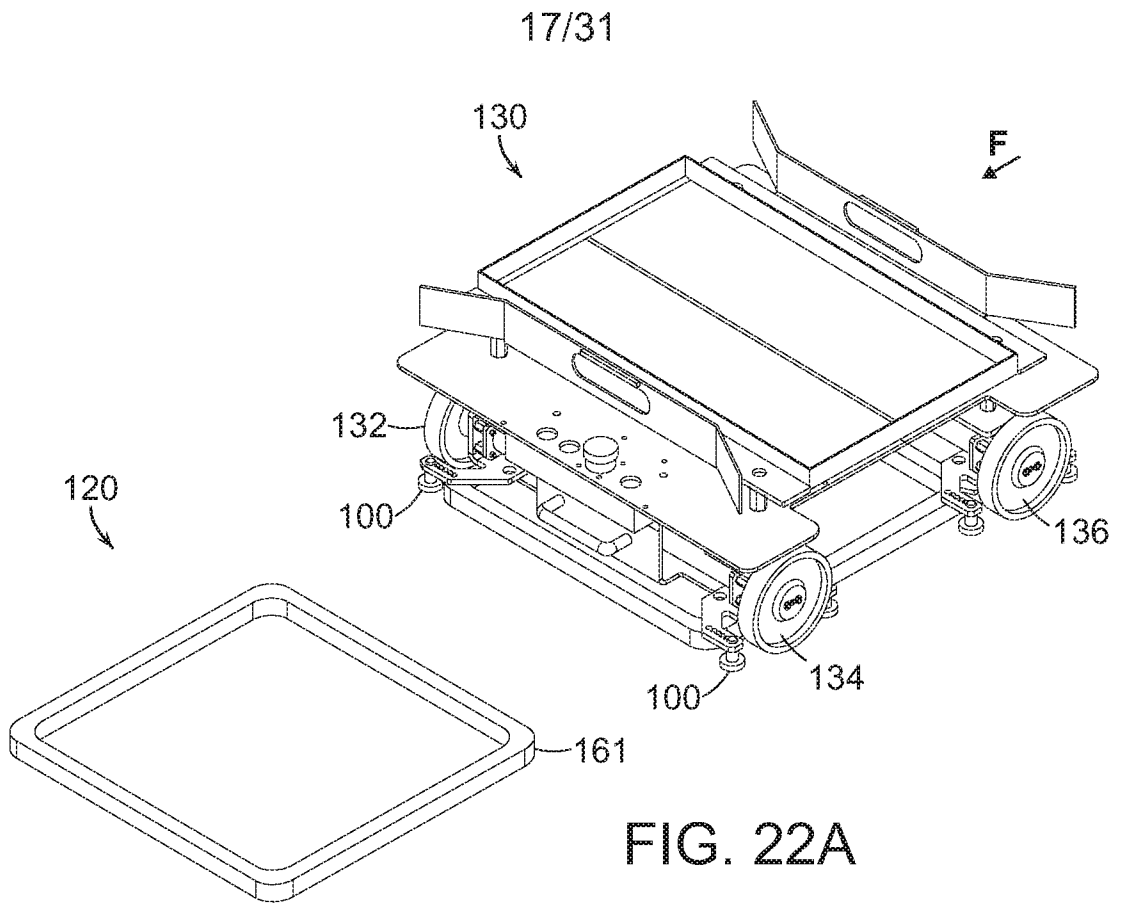

FIG. 21B



18/31

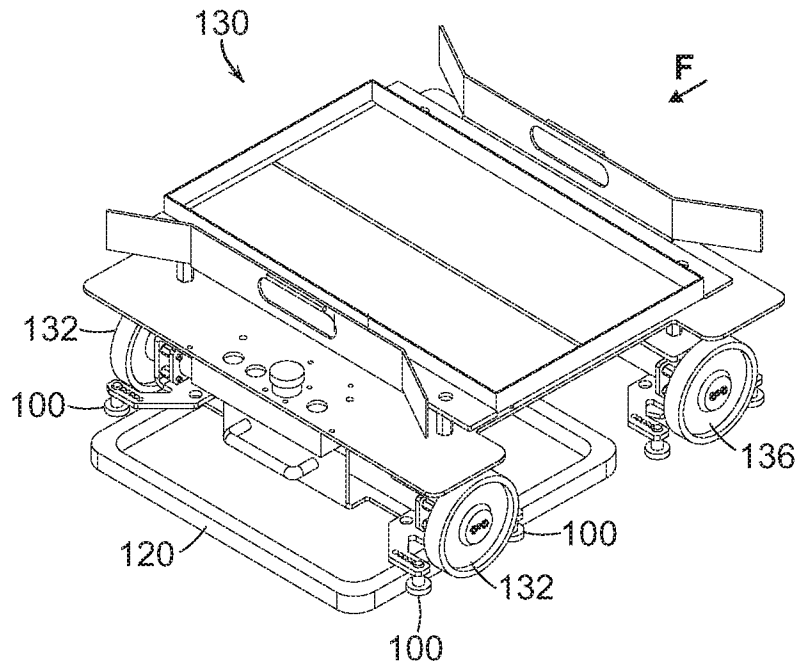

FIG. 22C

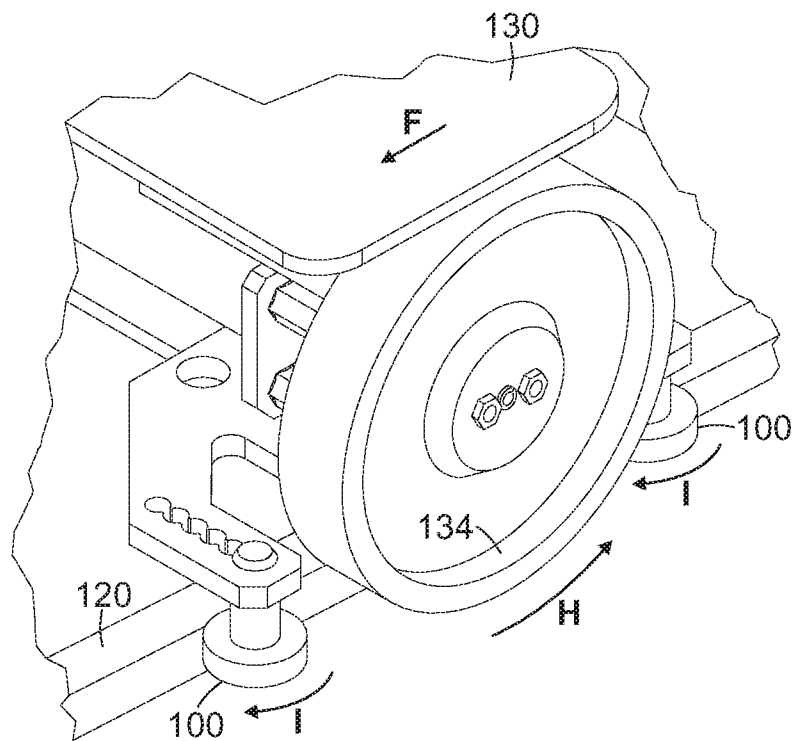

FIG. 23

19/31

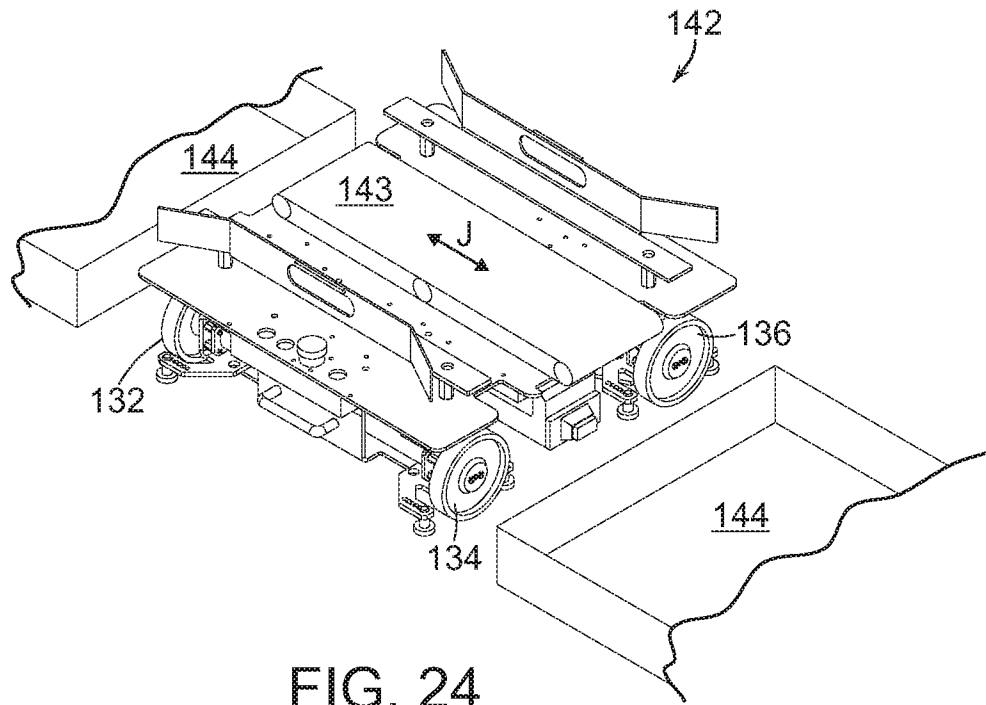

FIG. 24

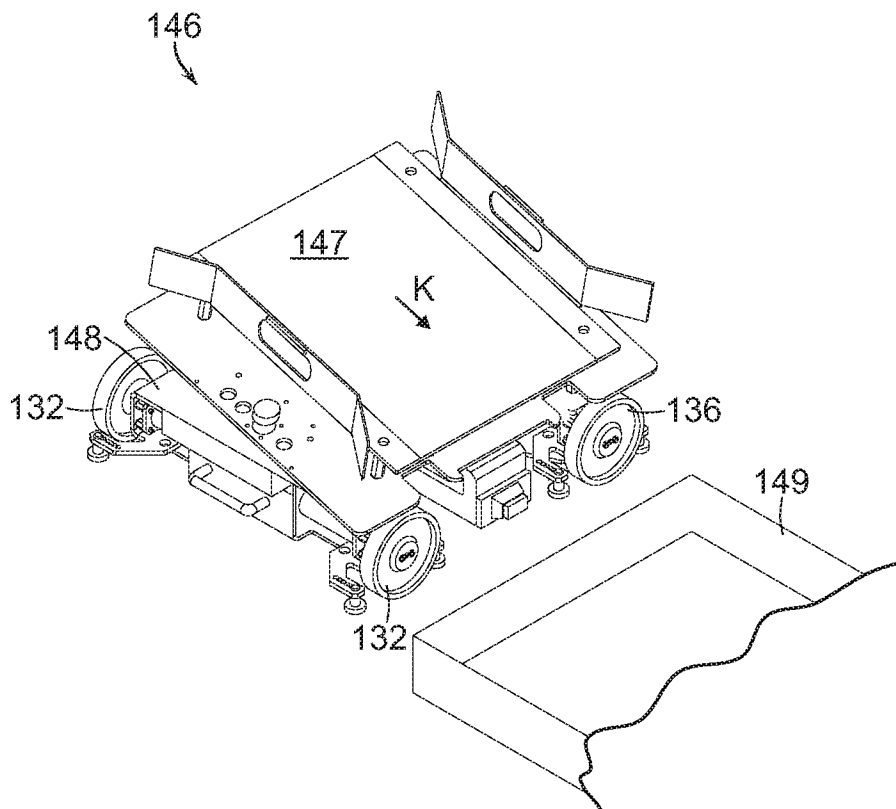

FIG. 25

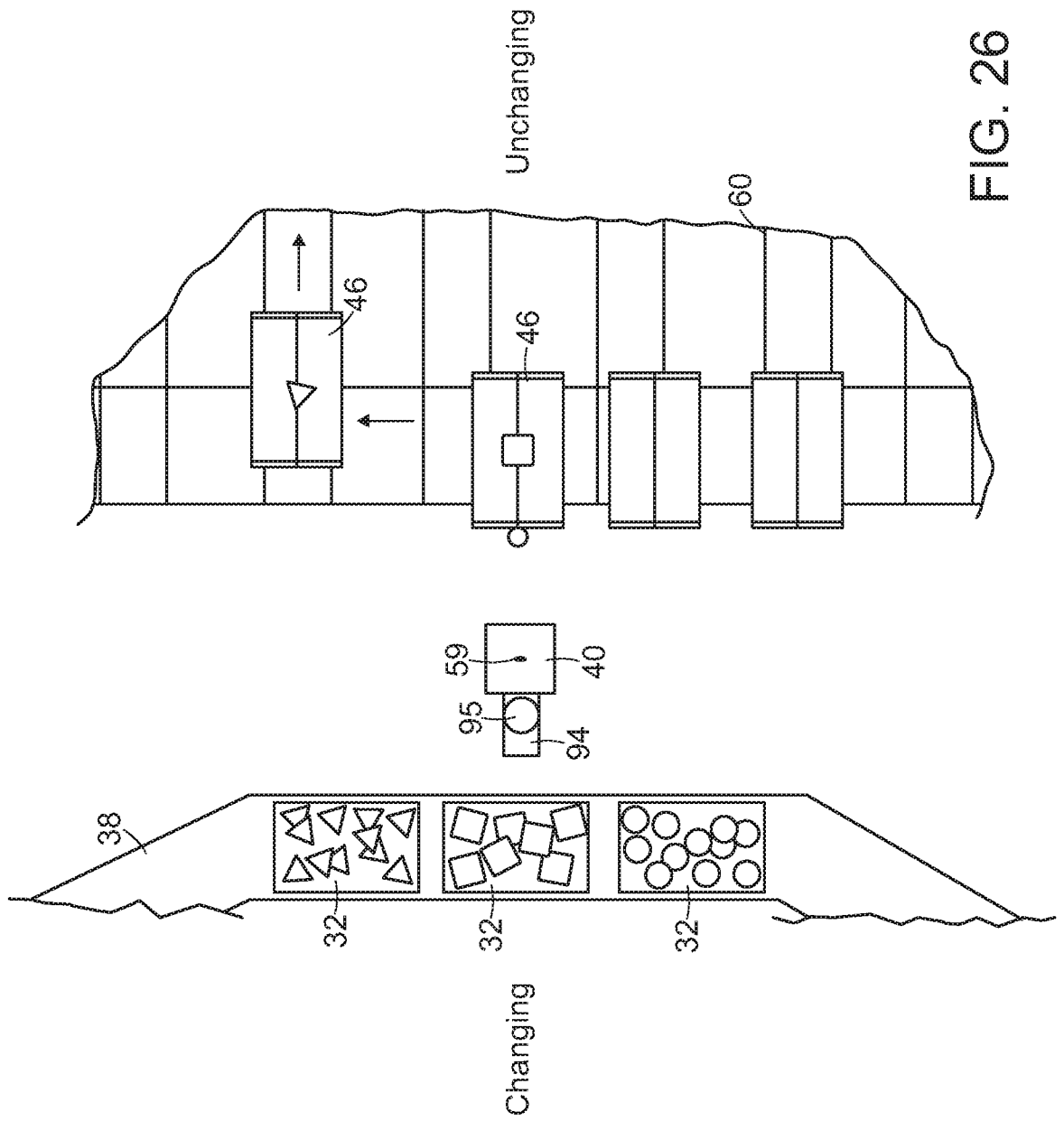

FIG. 26

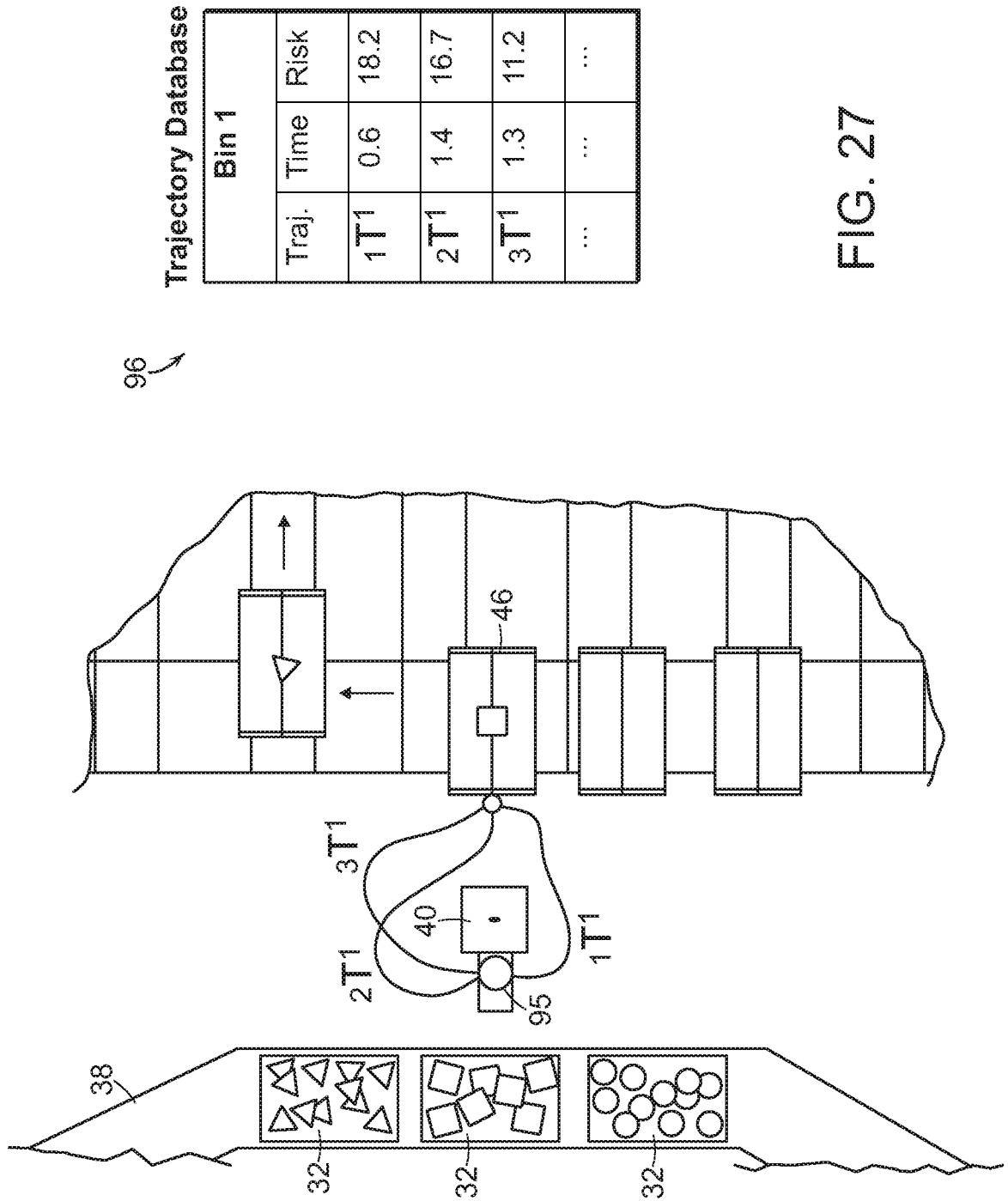

FIG. 27

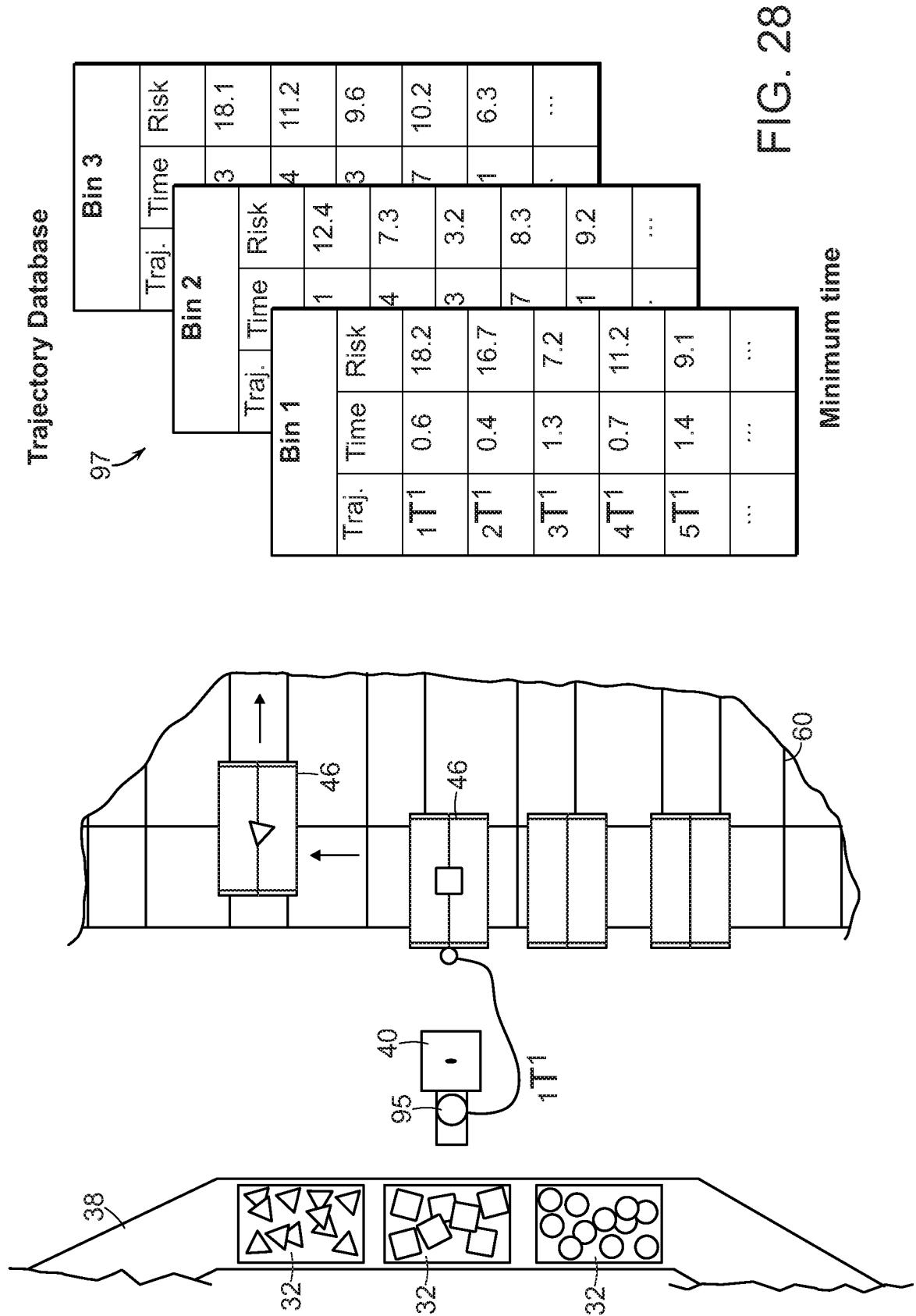

FIG. 28

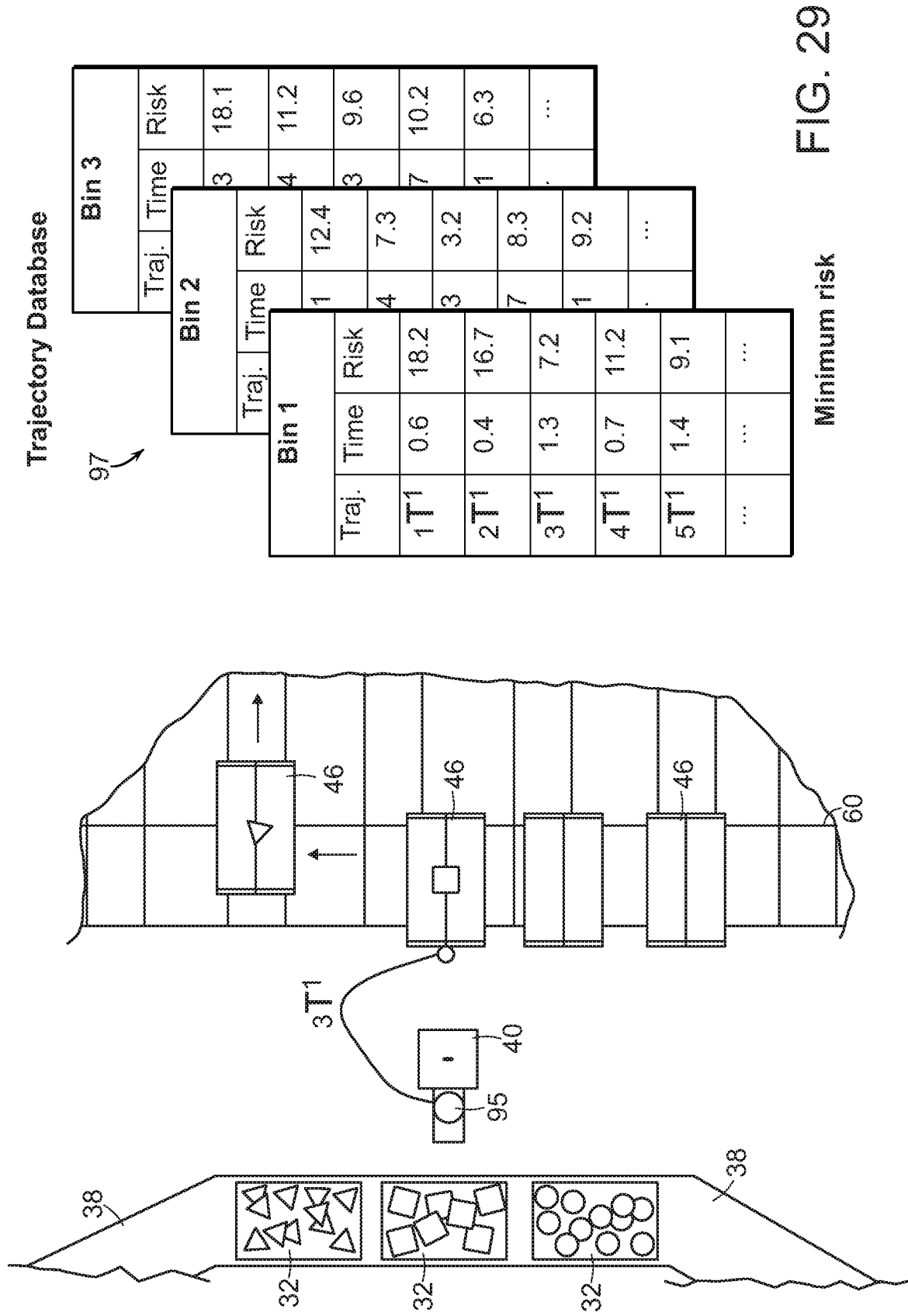

FIG. 29

24/31

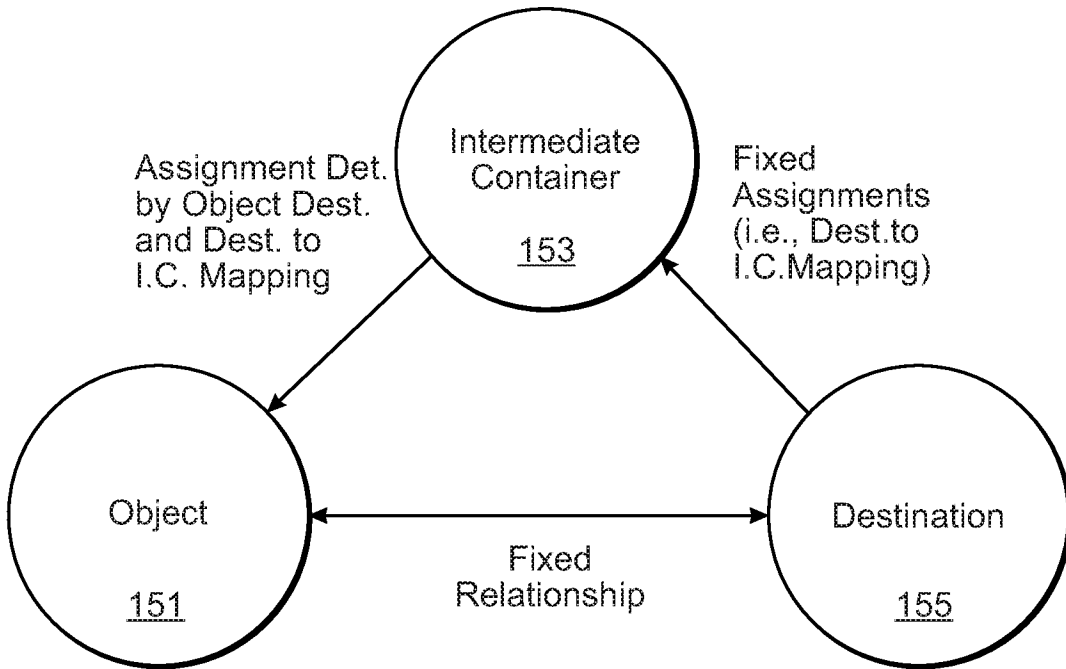

FIG. 30

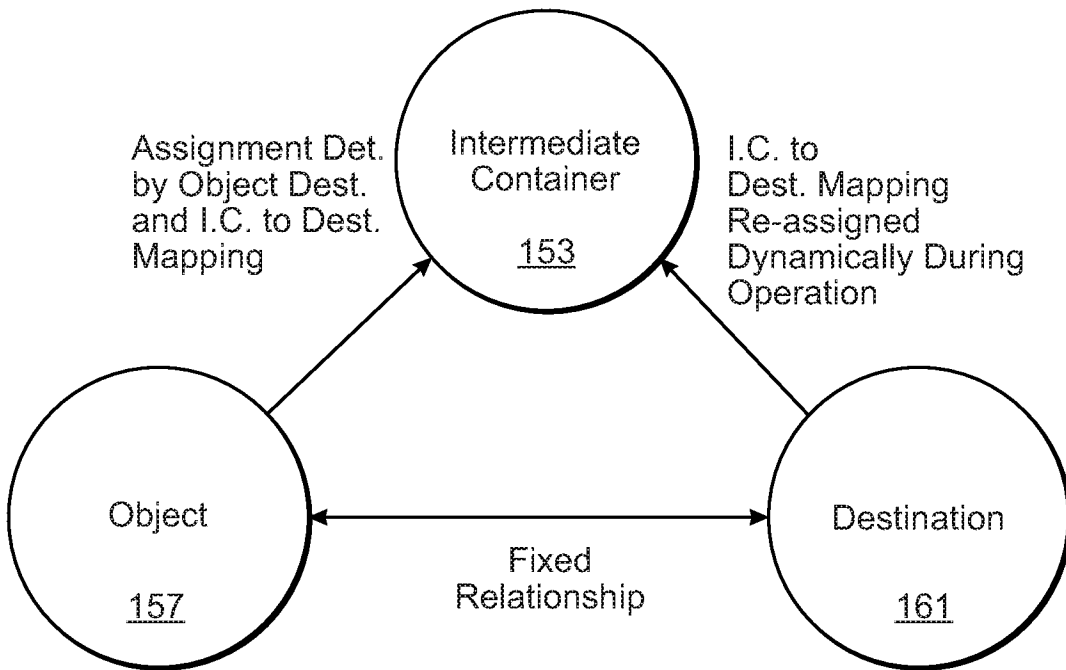

FIG. 31

25/31

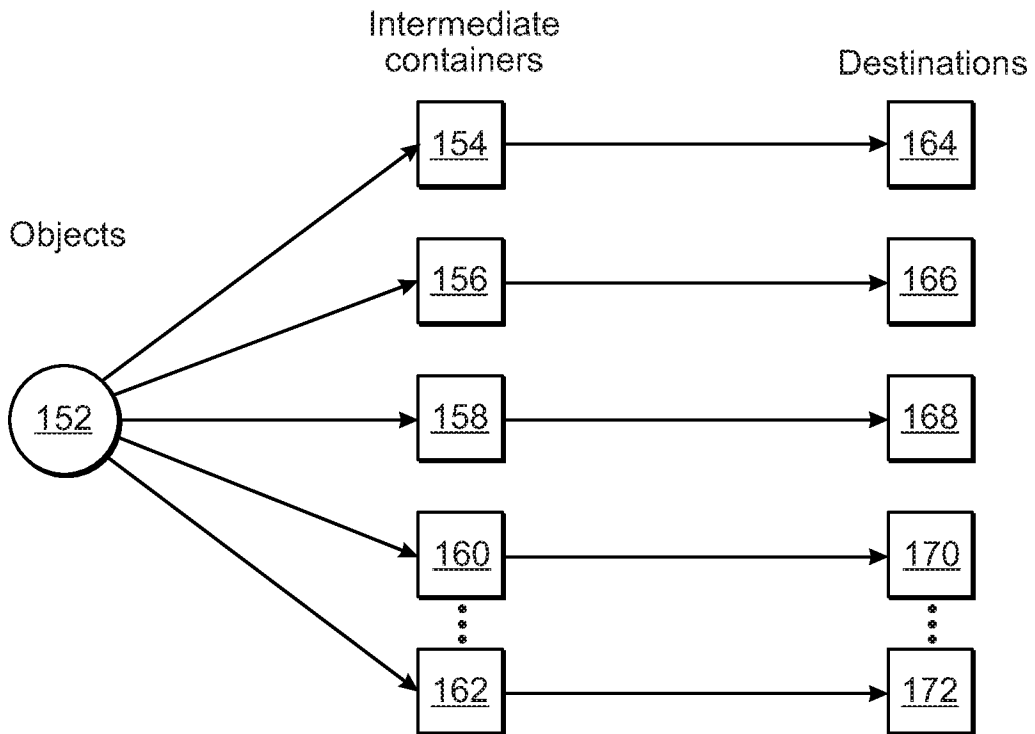

FIG. 32

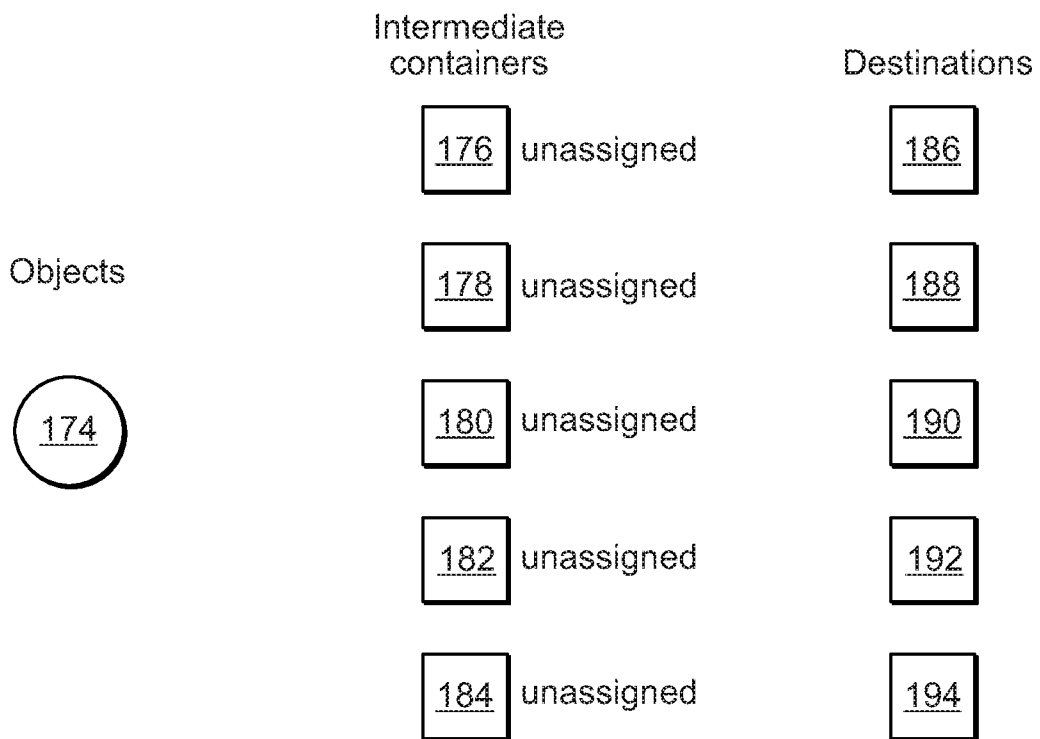

FIG. 33A

26/31

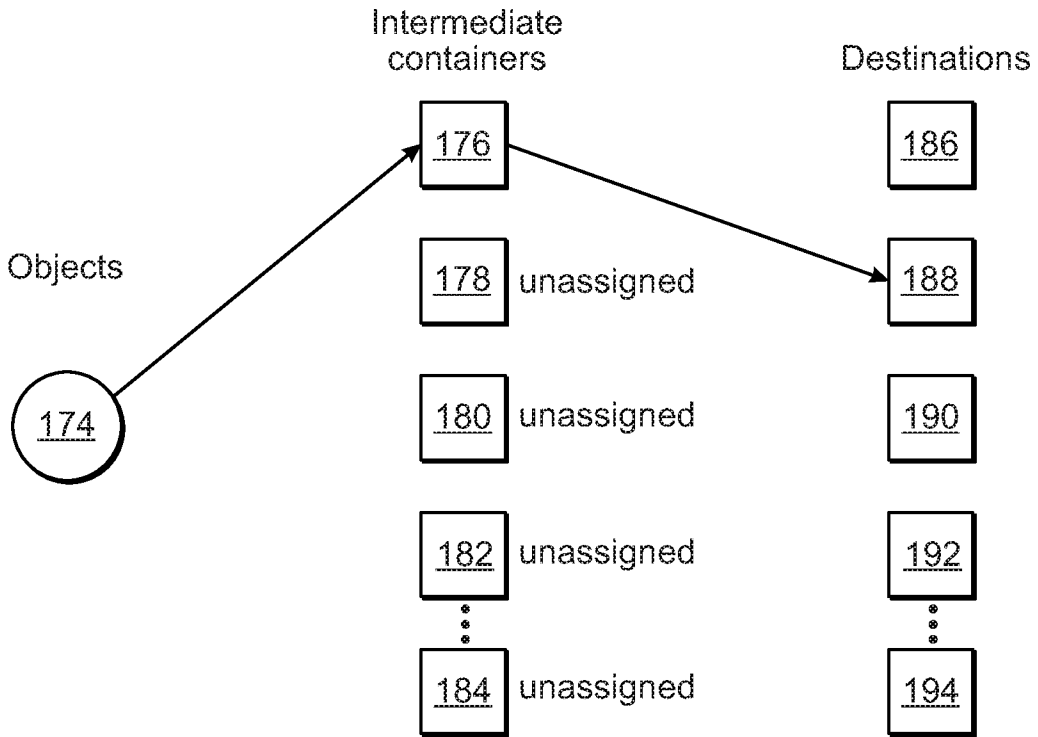

FIG. 33B

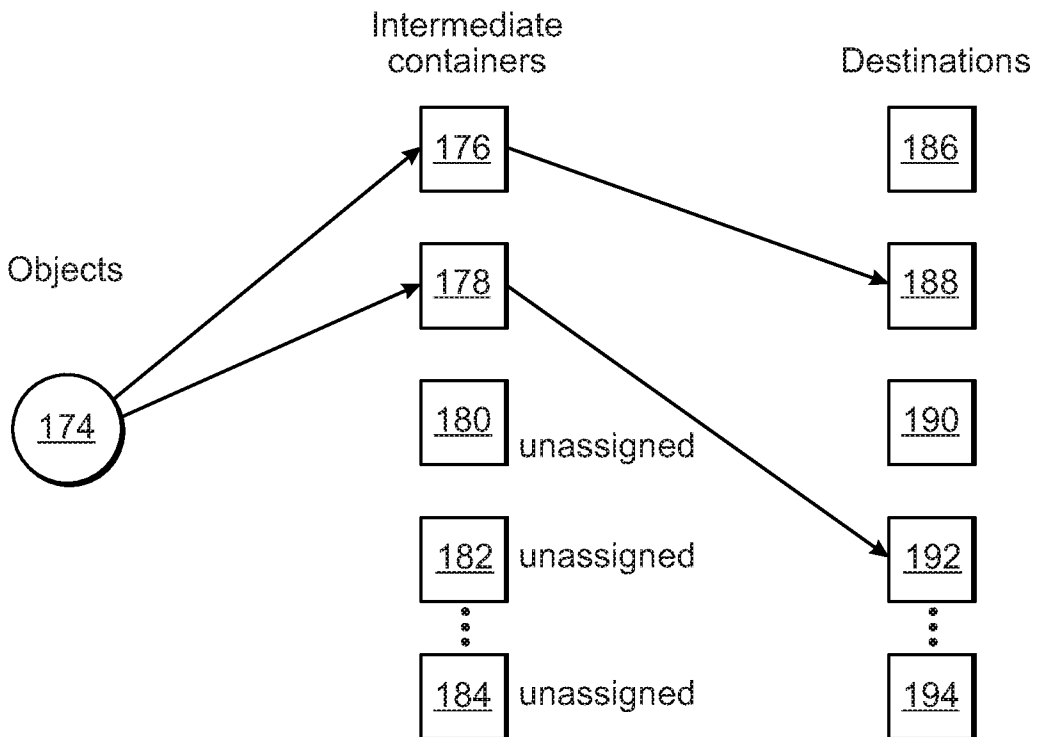

FIG. 33C

27/31

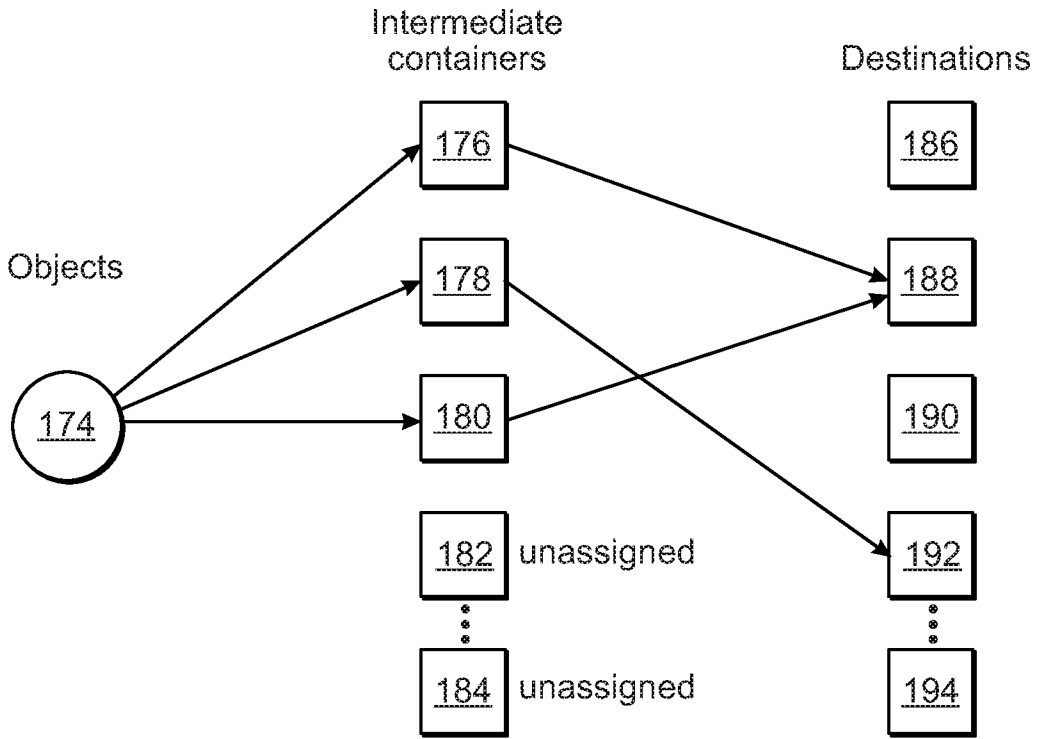

FIG. 33D

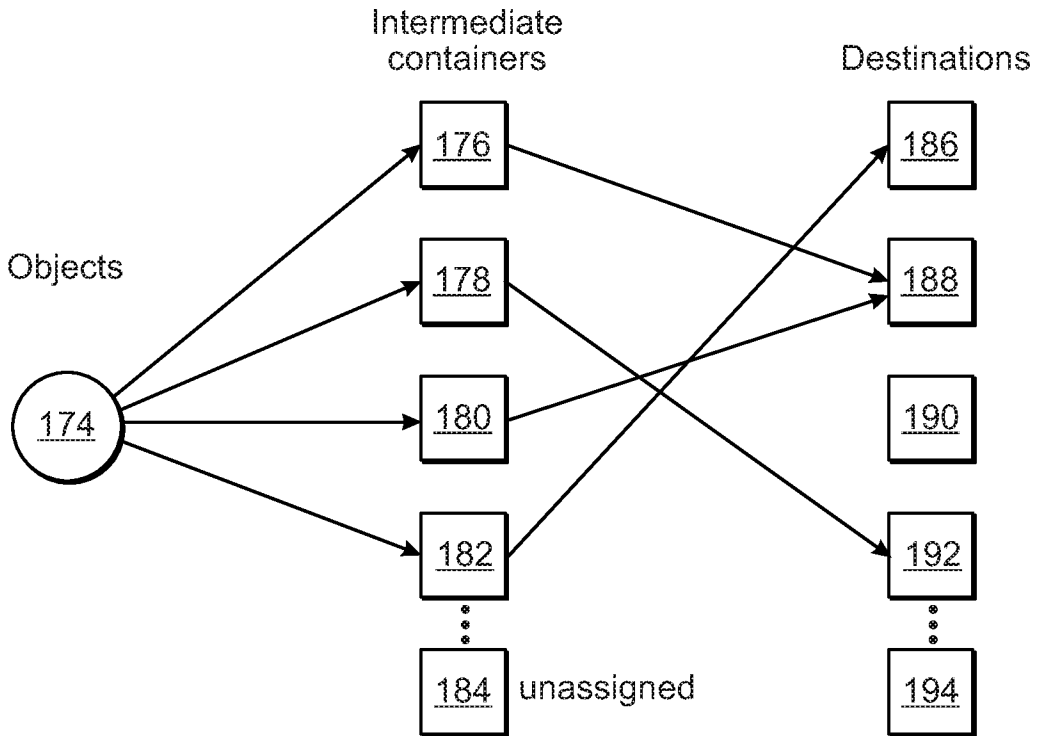

FIG. 33E

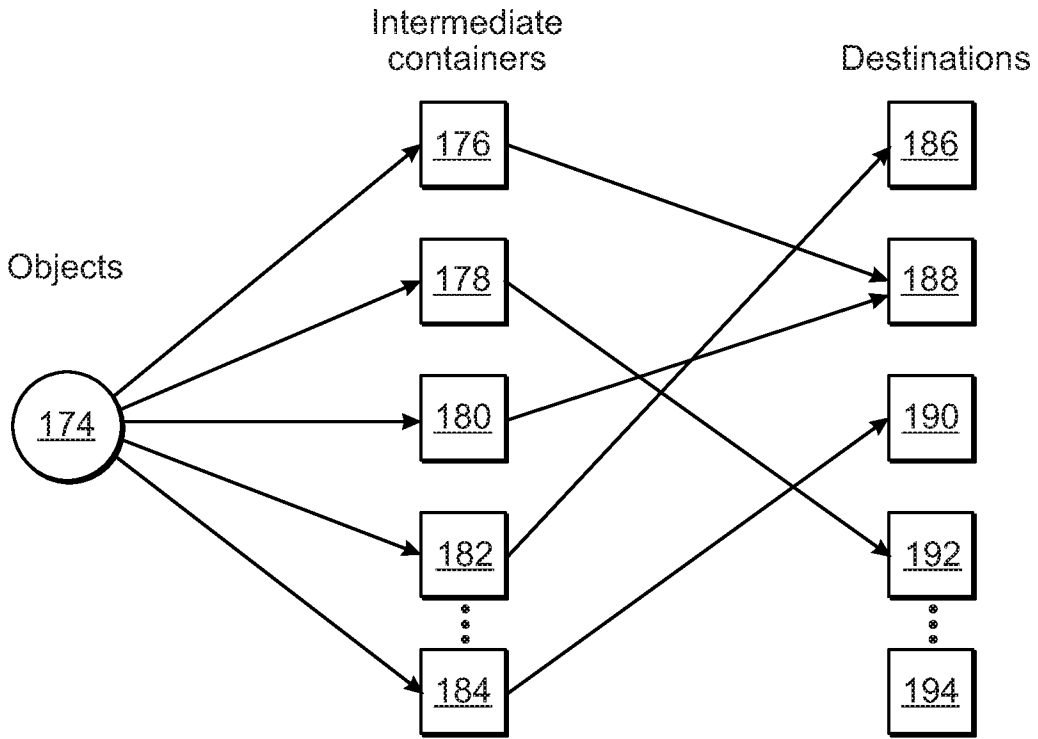

FIG. 33F

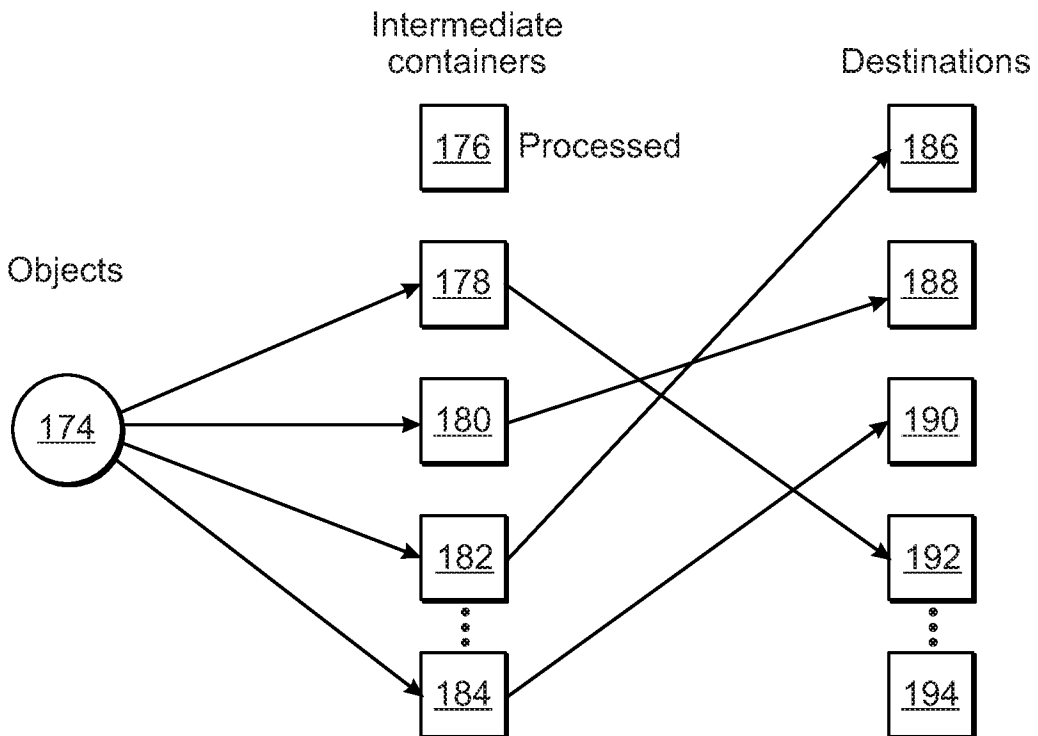

FIG. 33G

29/31

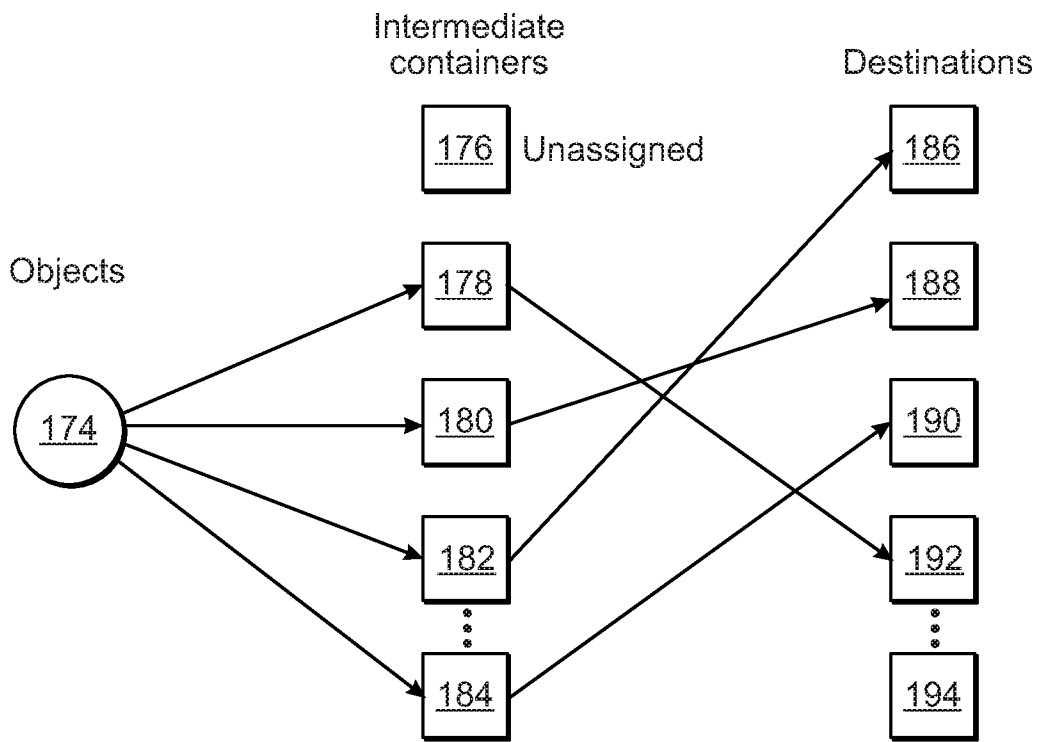

FIG. 33H

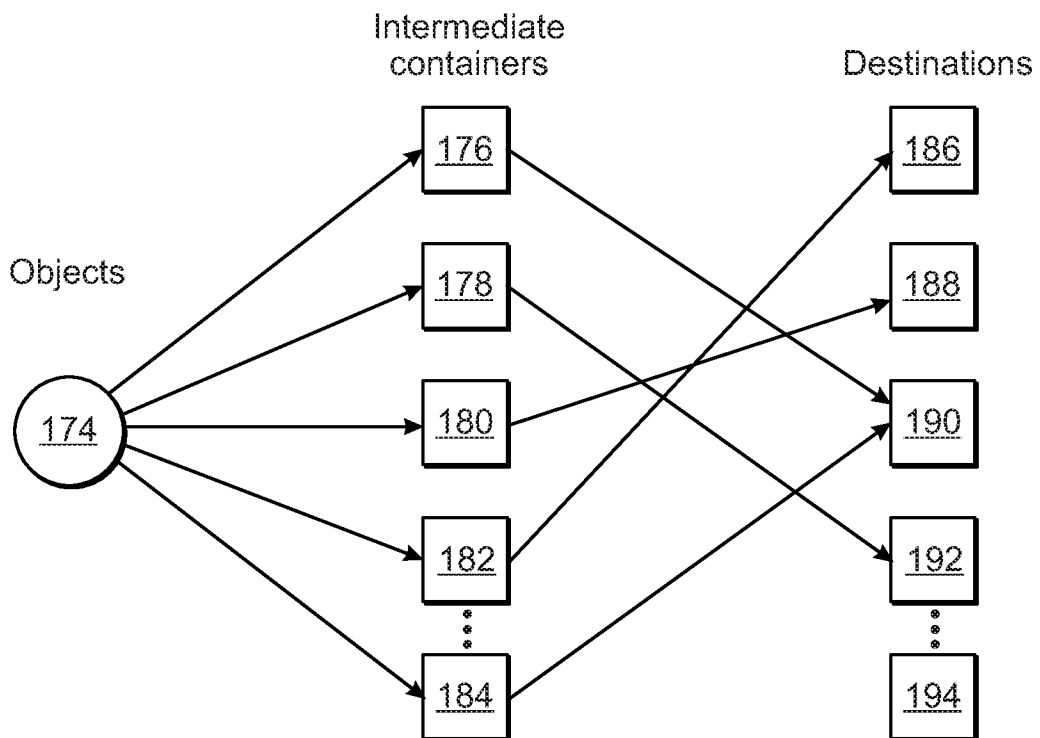

FIG. 33I

30/31

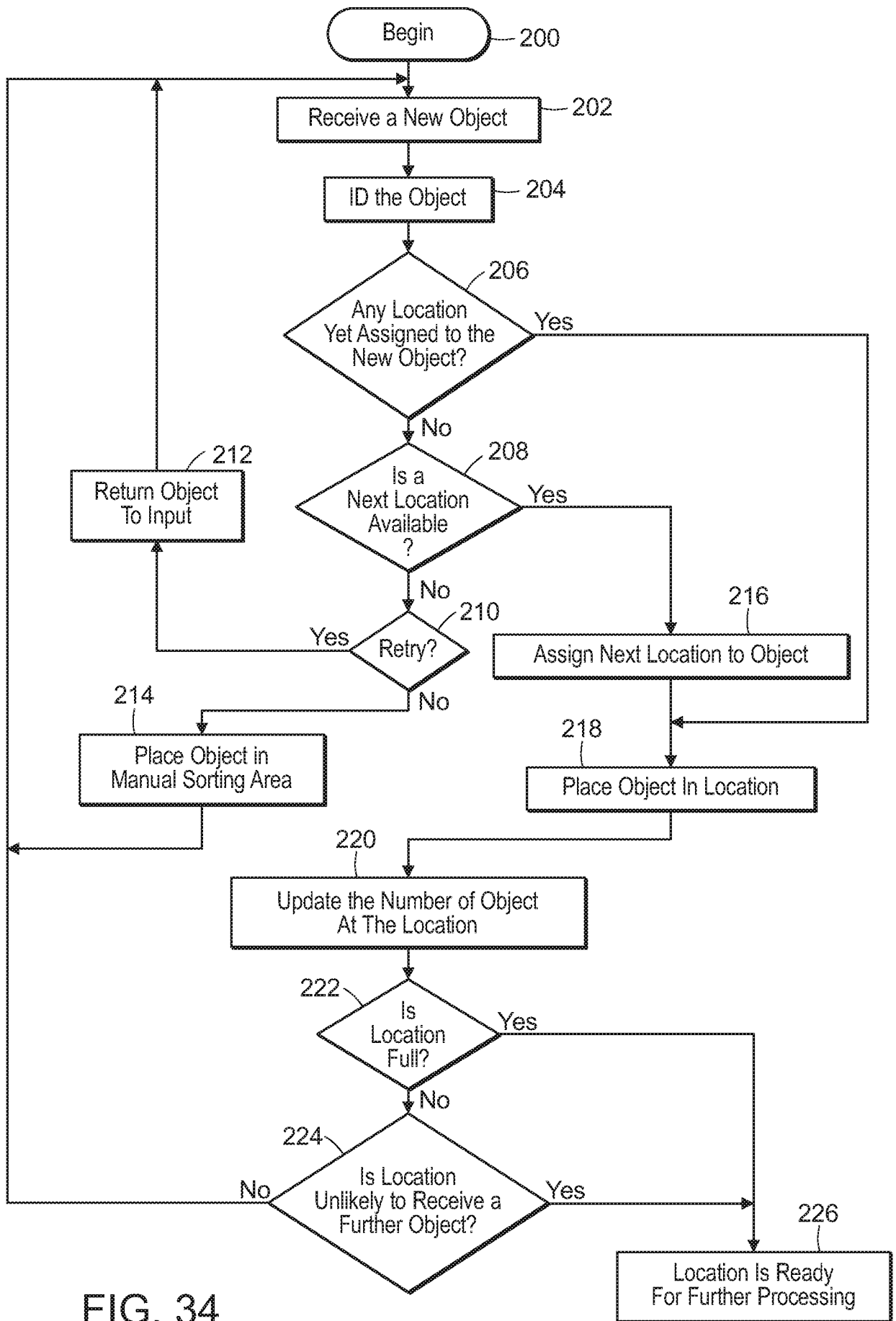

FIG. 34

31/31

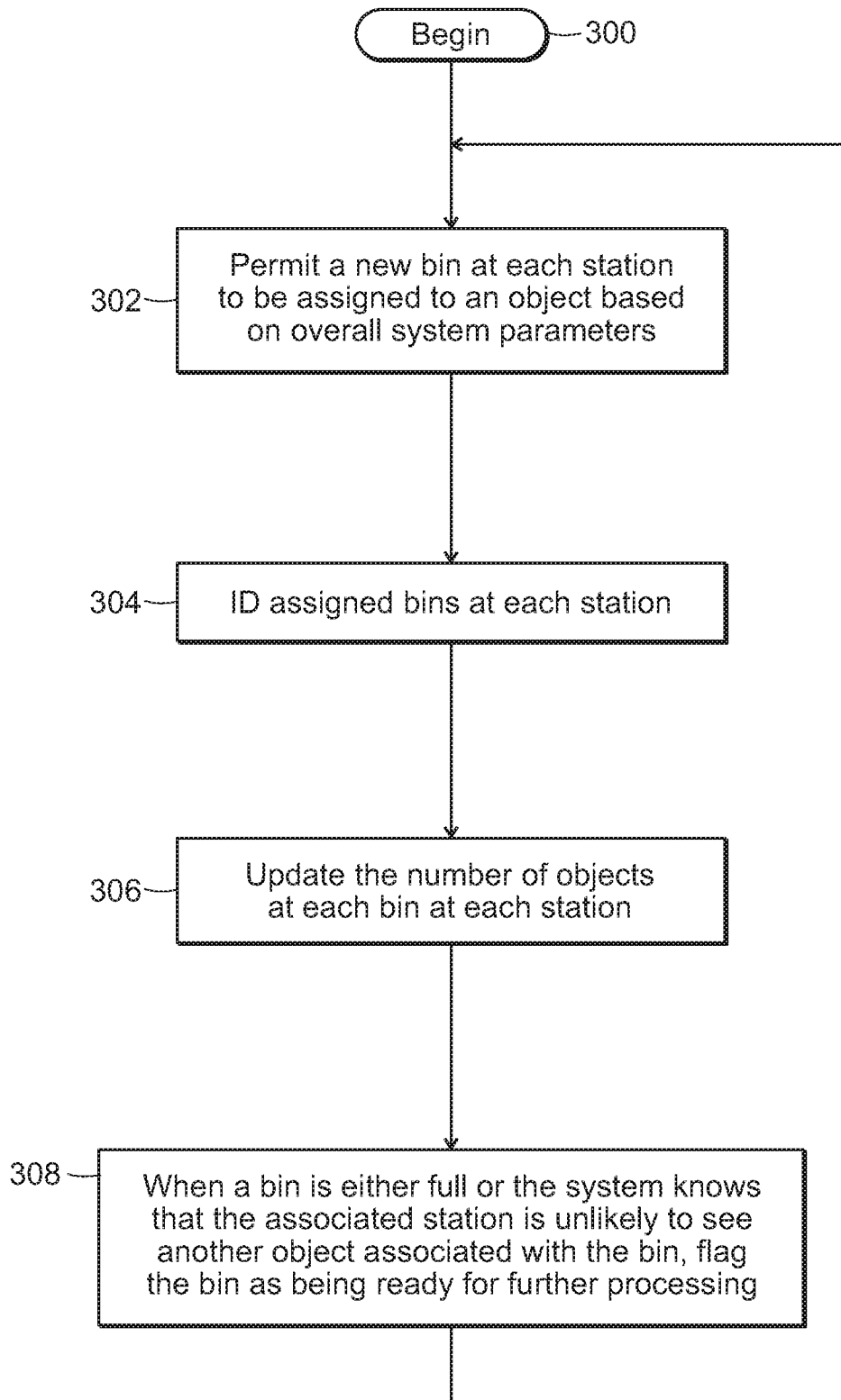

FIG. 35

INTERNATIONAL SEARCH REPORT

International application No
PCT/US2018/024065

A. CLASSIFICATION OF SUBJECT MATTER
 INV. B65G1/04 B65G1/137
 ADD.
 According to International Patent Classification (IPC) or to both national classification and IPC

B. FIELDS SEARCHED
 Minimum documentation searched (classification system followed by classification symbols)
 B65G

Documentation searched other than minimum documentation to the extent that such documents are included in the fields searched

Electronic data base consulted during the international search (name of data base and, where practicable, search terms used)
 EPO-Internal, WPI Data

C. DOCUMENTS CONSIDERED TO BE RELEVANT

Category*	Citation of document, with indication, where appropriate, of the relevant passages	Relevant to claim No.
Y	US 6 011 998 A (LICHTI WAYNE [US] ET AL) 4 January 2000 (2000-01-04)	1-3, 7-11, 22-25, 27-30
A	columns 1-14; figures 1-5 -----	14
A	US 2014/244026 A1 (NEISER RAYMOND R [US]) 28 August 2014 (2014-08-28) cited in the application pages 1-6; figures 1-4 -----	1
A	WO 2016/198565 A1 (JAKOB HATTELAND LOGISTICS AS [NO]) 15 December 2016 (2016-12-15) pages 1-12; figures 1-7 ----- -/--	1

Further documents are listed in the continuation of Box C.

See patent family annex.

* Special categories of cited documents :

<p>"A" document defining the general state of the art which is not considered to be of particular relevance</p> <p>"E" earlier application or patent but published on or after the international filing date</p> <p>"L" document which may throw doubts on priority claim(s) or which is cited to establish the publication date of another citation or other special reason (as specified)</p> <p>"O" document referring to an oral disclosure, use, exhibition or other means</p> <p>"P" document published prior to the international filing date but later than the priority date claimed</p>	<p>"T" later document published after the international filing date or priority date and not in conflict with the application but cited to understand the principle or theory underlying the invention</p> <p>"X" document of particular relevance; the claimed invention cannot be considered novel or cannot be considered to involve an inventive step when the document is taken alone</p> <p>"Y" document of particular relevance; the claimed invention cannot be considered to involve an inventive step when the document is combined with one or more other such documents, such combination being obvious to a person skilled in the art</p> <p>"&" document member of the same patent family</p>
---	---

Date of the actual completion of the international search 21 June 2018	Date of mailing of the international search report 29/06/2018
---	--

Name and mailing address of the ISA/ European Patent Office, P.B. 5818 Patentlaan 2 NL - 2280 HV Rijswijk Tel. (+31-70) 340-2040, Fax: (+31-70) 340-3016	Authorized officer Martin, Benoit
--	--

INTERNATIONAL SEARCH REPORT

International application No
PCT/US2018/024065

C(Continuation). DOCUMENTS CONSIDERED TO BE RELEVANT		
Category*	Citation of document, with indication, where appropriate, of the relevant passages	Relevant to claim No.
Y	JP 2014 141313 A (JB CREATE CO LTD) 7 August 2014 (2014-08-07) figures 1-3 -----	1-3, 7-11, 22-25, 27-30
A	EP 2 745 982 A2 (IDENTYTEC GMBH & CO KG [DE]) 25 June 2014 (2014-06-25) columns 1-25; figures 1-7 -----	1
A	EP 0 235 488 A1 (REDOUTE CATALOGUE SA [FR]) 9 September 1987 (1987-09-09) columns 1-28; figures 1-14 -----	1
Y	US 6 059 092 A (JERUE ROY A [US] ET AL) 9 May 2000 (2000-05-09) columns 1-6; figures 1-3 -----	1,4-6, 12-22, 26,29
Y	JP H08 157016 A (MITSUBISHI HEAVY IND LTD) 18 June 1996 (1996-06-18) abstract; figures 1-15 -----	1,4-6, 12-22, 26,29
A	US 2014/277693 A1 (NAYLOR JOHN R [US]) 18 September 2014 (2014-09-18) pages 1-6; figures 1-33 -----	1
A	US 6 579 053 B1 (GRAMS ROBERT S [US] ET AL) 17 June 2003 (2003-06-17) columns 1-14; figures 1-24 -----	2,13,23
A	DE 195 10 392 A1 (SIEMENS AG [DE]) 26 September 1996 (1996-09-26) columns 1-4; figures 1,2 -----	6
A	US 2015/098775 A1 (RAZUMOV SERGEY N [RU]) 9 April 2015 (2015-04-09) pages 1-6; figures 1-13 -----	6
A	US 2009/026017 A1 (FREUDELSPERGER KARL [AT]) 29 January 2009 (2009-01-29) pages 1-4; figures 1-7 -----	6

INTERNATIONAL SEARCH REPORT

Information on patent family members

International application No
PCT/US2018/024065

Patent document cited in search report	Publication date	Publication date	Patent family member(s)	Publication date
US 6011998	A	04-01-2000	NONE	

US 2014244026	A1	28-08-2014	US 2014244026 A1	28-08-2014
			WO 2014130937 A1	28-08-2014

WO 2016198565	A1	15-12-2016	AU 2016277470 A1	04-01-2018
			CA 2986315 A1	15-12-2016
			CN 107708940 A	16-02-2018
			EP 3307654 A1	18-04-2018
			NO 339783 B1	30-01-2017
			WO 2016198565 A1	15-12-2016

JP 2014141313	A	07-08-2014	NONE	

EP 2745982	A2	25-06-2014	DE 102012024038 A1	12-06-2014
			DE 202013012530 U1	27-04-2017
			EP 2745982 A2	25-06-2014

EP 0235488	A1	09-09-1987	EP 0235488 A1	09-09-1987
			US 4678390 A	07-07-1987

US 6059092	A	09-05-2000	NONE	

JP H08157016	A	18-06-1996	NONE	

US 2014277693	A1	18-09-2014	US 2014277693 A1	18-09-2014
			US 2015239667 A1	27-08-2015
			WO 2014152476 A1	25-09-2014

US 6579053	B1	17-06-2003	CA 2300684 A1	15-09-2000
			CA 2300685 A1	15-09-2000
			CA 2300686 A1	15-09-2000
			US 6447236 B1	10-09-2002
			US 6579053 B1	17-06-2003
			US 2003123970 A1	03-07-2003

DE 19510392	A1	26-09-1996	NONE	

US 2015098775	A1	09-04-2015	EP 3055230 A1	17-08-2016
			US 2015098775 A1	09-04-2015
			WO 2015052560 A1	16-04-2015

US 2009026017	A1	29-01-2009	AT 469848 T	15-06-2010
			DE 102006007364 A1	23-08-2007
			EP 1986937 A1	05-11-2008
			ES 2346482 T3	15-10-2010
			US 2009026017 A1	29-01-2009
			WO 2007093383 A1	23-08-2007
