



(22) Date de dépôt/Filing Date: 2000/08/08
 (41) Mise à la disp. pub./Open to Public Insp.: 2001/09/07
 (45) Date de délivrance/Issue Date: 2007/10/23
 (30) Priorité/Priority: 2000/03/07 (ESP200000551)

(51) Cl.Int./Int.Cl. *B32B 7/12* (2006.01),
B29C 70/44 (2006.01), *B64C 3/18* (2006.01),
B64C 3/24 (2006.01)

(72) Inventeurs/Inventors:
 CEREZO PANCORBO, CARLOS, ES;
 DOMINGUEZ CASADO, RAFAEL, ES;
 DE CASTRO NODAL, MANUEL, ES;
 PEREZ PASTOR, AUGUSTO, ES;
 GARCIA GARCIA, AQUILINO, ES;
 HUERTAS GARCIA, MANUEL, ES

(73) Propriétaire/Owner:
 AIRBUS ESPANA, S.L., ES

(74) Agent: OGILVY RENAULT LLP/S.E.N.C.R.L.,S.R.L.

(54) Titre : PROCESSUS DE FABRICATION DE PIECES PREPOLYMERISEES DE MATERIAU COMPOSITE AVEC
 ENTRETOISES DE MAINTIEN APPLIQUEES
 (54) Title: PROCESS FOR MANUFACTURING PRE-CURED PARTS OF COMPOSITE MATERIAL WITH GREEN-
 APPLIED STIFFENERS

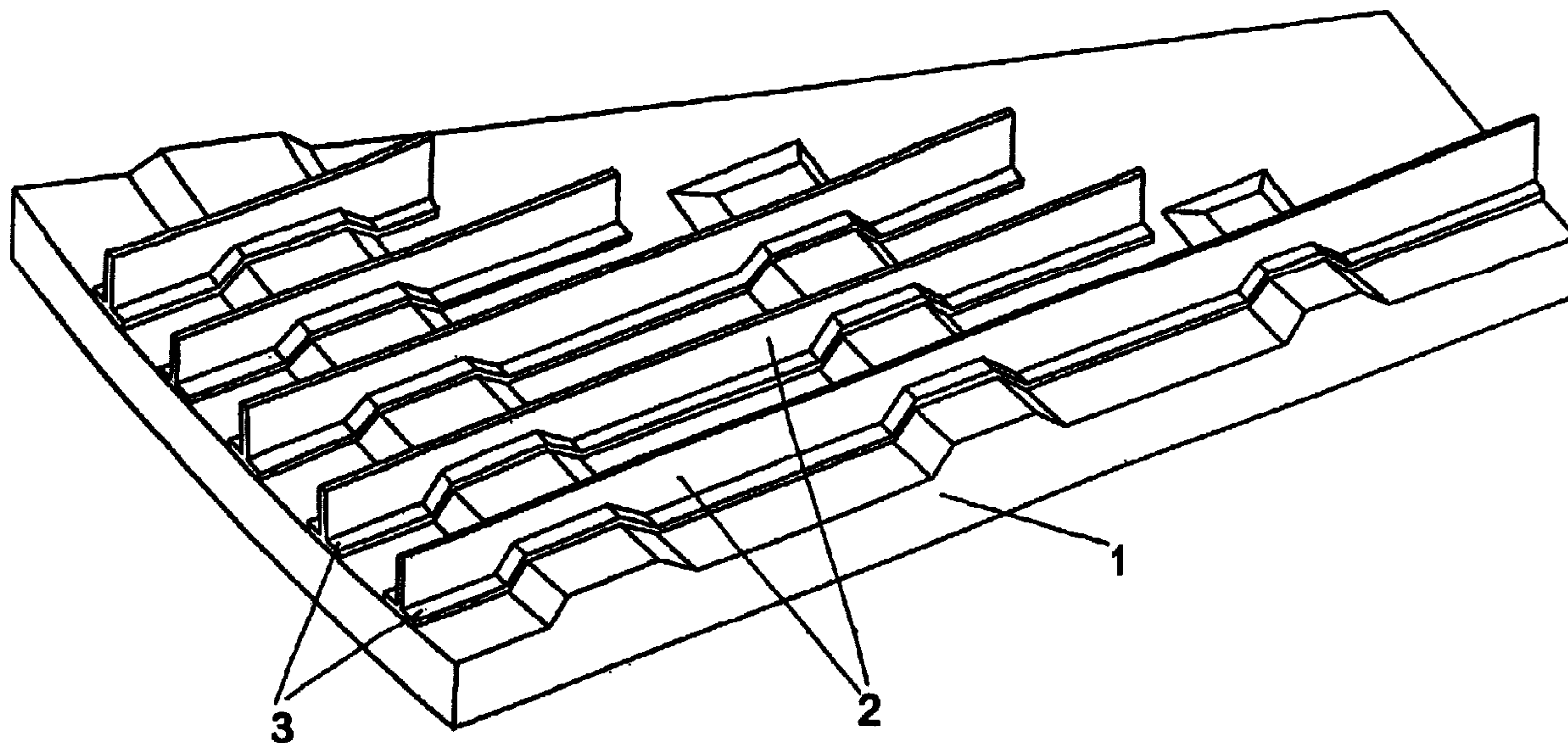

(57) Abrégé/Abstract:

A process for manufacturing pre-cured parts of composite material with green-applied stiffeners, comprising the lamination of superimposed pre-impregnated composite material sheets to obtain a base part (1) and a second part (2) intended to be bonded with it; curing the base part (1); hot forming the laminate destined to form the second part (2); removing the second part (2) from the forming tool thereof and deposit it over the base part (1), intercalating a structural adhesive sheet between both of them; closing the assembly of both parts inside a vacuum bag and loading said bag in an autoclave, carrying out a curing cycle of the second part (2) under pressure and temperature, so that it is strongly adhered to the base part (1). The invention is applicable to the field of aeronautics.

ABSTRACT

A process for manufacturing pre-cured parts of composite material with green-applied stiffeners, comprising the lamination of superimposed pre-impregnated composite material sheets to obtain a base part (1) and a second part (2) intended to be bonded with it; curing the base part (1); hot forming the laminate destined to form the second part (2); removing the second part (2) from the forming tool thereof and deposit it over the base part (1), intercalating a structural adhesive sheet between both of them; closing the assembly of both parts inside a vacuum bag and loading said bag in an autoclave, carrying out a curing cycle of the second part (2) under pressure and temperature, so that it is strongly adhered to the base part (1). The invention is applicable to the field of aeronautics.

PROCESS FOR MANUFACTURING PRE-CURED PARTS OF COMPOSITE
MATERIAL WITH GREEN-APPLIED STIFFENERS

FIELD OF THE INVENTION

5 The present invention refers to a process for
manufacturing pre-cured parts of composite material with
green-applied stiffeners, in which at least two parts
manufactured in composite materials are structurally bonded,
of which a first part called base part or support is cured
10 and a second part called stiffener is in green condition and
in which the bonding of both parts is carried out by means
of a structural adhesive sheet in such a way that the second
part is compacted against the first part, with adequate
crosslinking of the resin of its composite material and so
15 strongly adhered to the skin of the first part that the
adequate resistance of the adhesive sheet is assured.

 More specifically, the object of the invention is to
develop the necessary theoretical concepts and their
corresponding manufacturing processes to obtain a bonding
20 system by co-gluing two or more structural parts
manufactured in composite materials.

 The bond is carried out by means of autoclave curing
of a structural adhesive sheet interposed between two
surfaces of parts made of composite material. The resin is
25 cured in one of these parts and green in the other one. The
curing of the resin of the part which is in a green
condition is also produced in the same autoclave cycle.

 One of the most productive industrial applications of
the present invention is the manufacture of big size parts
30 where the quality of the base part is assured, that is, the
part arriving already cured to the process.

BACKGROUND OF THE INVENTION

 The adhesive joints of structural components have a
reduced application in composite materials due to the fact
35 that their use and development degree is limited as
corresponds to their recent appearance in the technical
background.

In the case of co-gluing, the applicant's closest background refers to the bonding of spar stiffeners of the horizontal stabilizer torsion box for the Airbus A330-340 aircraft (currently in production), the bonding of the longitudinal stiffeners of the coatings of the wing torsion box for the CASA 3000 aircraft (in prototype stage), the bonding of spars to the wing coating of the EFA-European Fighter Aircraft (in pre-production phase) and the bonding of the FB.5-1 test box of the LFS-Large Flying-Surfaces development programme.

From the results of the previous experiments as well as from other studies and manufacturability tests, it is deduced that the application of the process of the present invention is both achievable and reliable for its use in parts with highly demanded resistant structures and with strict quality requirements.

FIELD OF APPLICATION OF THE INVENTION

This invention is applicable to the manufacture of composite material parts in which one or several of its components are in a cured condition (base components) and the other components are in a green condition (stiffener components), provided that the bonding between both of them is made. These parts may be any of those belonging to:

- Aircraft structures and controls such as flying-surface coatings, spars, ribs, fixtures.
- Space vehicles.
- Marine and land vehicles.
- Industrial machinery and equipment.

The manufacturing processes involved are:

- Laminating of composite material (manual or automatic).
- Cutting of composite material.
- Hot forming of composite material.
- Handling and positioning of parts and tooling.
- Autoclave curing.

The used materials may be integrated by different resins and different types of fibre, such as:

- Fiberglass.
- Carbon fibre
- Kevlar fibre
- Boron fibre
- 5 - Epoxy resin.
- Thermoplastic resin
- Other heat-stable resins

SUMMARY OF THE INVENTION

The object of the invention is a manufacturing process
10 for composite material parts in which at least one green
part is adhered (stiffener component) with another cured
part (base component) by means of a structural adhesive.
This bonding is obtained by the moulding and pressure
application with special tools designed for such purpose, so
15 that it is possible to control and retain the resin and
adhesive flow produced during the autoclave cycle.

The green part will have an L- or T-shaped cross
section. The process for the latter will be described in
detail below.

20 The cured part may be a wing skin or that of a
stabiliser or any other component needing to be stiffened in
order to comply with its structural function.

The co-stiffener with a T-shape is confined by devices
(angle pieces) which are the basis of the system and which
25 control and retain the resin flow. Afterwards, a vacuum bag
is fitted as will be explained later on, and the assembly is
introduced into an autoclave to submit it to a curing cycle
under a predetermined pressure and temperature depending on
the material and part requirements.

30 The process is applicable to the parts obtained by any
lamination process (manual or automatic).

BRIEF DESCRIPTION OF THE DRAWINGS

For a better understanding of the process of the
present invention, the attached drawings will be resorted
35 to, where:

- Figure 1 is a general perspective view of a base skin-
stiffener assembly obtained with the process of the

invention,

- Figure 2 shows angle pieces used in the present invention,

5 - Figure 3 is a perspective view of a stopper used in the present invention,

- Figure 4 illustrates the formation of a semi-stringer according to the present invention, and

- Figure 5 shows the bonding of the semi-stringers by using the process of the invention.

10 DETAILED DESCRIPTION OF THE INVENTION

The manufacturing process developed by the invention and applicable to composite materials is related to a set of different preliminary processes allowing to achieve co-gluing in a optimized way. The key point is the retention of resin flow of the composite material during the co-gluing process described below.

This co-gluing process consists of the structural bonding of an already cured part 1 (base skin) with a stiffener component 2 in a green condition (stringer).

20 The foot 3 of the stringer 2 is of a constant thickness in each section and is adapted to the shape of the coating of the base part 1, ascending and descending the slopes of the latter as may be observed in figure 1. The thicknesses developed until now for such a foot vary between 25 2 and 8 mm.

The stringer 2 is confined between two angle pieces 4, 4' of steel, aluminium, pneumatic cushion, etc., preferably Invar, like those shown in figure 2 which are adapted to the shape of the stringer 2. These angle pieces have a series of channels where elastomeric pipes 5, 5' are housed, retaining the resin flow of the composite material of the stringer 2. The location, shape and exact sizing of such pipes is carried out according to the aforementioned resin flow optimisation and that of the grip-torque over the stringer 2 during the curing process.

35 Once the stringers 2 have been fitted over the angle pieces 4, 4', the adhesive is applied over the feet 3 of the

former ones. Then, the assembly is positioned over the base skin (part 1) and the relevant vacuum bag which envelops the entire assembly is made.

5 With respect to the tooling for the co-gluing process, a cradle over which part 1 has been cured will be used as well as a turning frame which will allow the stringers 2 to be correctly positioned over said part 1. The former ones are fastened to the frame by means of the angle pieces 4,4' described above.

10 To retain the resin flow at the ends, stoppers 6 of steel, aluminium, carbon fibre, etc. are used as shown in figure 3.

Now, the different steps of the manufacturing process according to the invention will be described.

15 A - Lamination of the part or parts

This consists in the superposition of composite material layers in a pre-impregnated condition, so that the orientation of the fibre is adapted to the structural requirements of the part to be manufactured. For such a purpose, the necessary reinforcements will be placed between the different laminate layers, designated with number 7 in figure 4. The distribution of layers must be such that their lamination and forming is permitted without producing wrinkles or fibre distortion and also that the part, once cured, has no permanent deformations due to thermal stresses.

On one hand, the base skin (part 1) and on the other hand the assembly of basic stacks forming the stringers 2 are laminated.

30 The parts made with the present process may be flat or curved, with or without changes of thickness, both transverse and longitudinal. Said parts may be subjected to a posterior cutting according to the convenience of laminating several parts at the same time.

35 B - Forming of the stringers and preliminary operations

The different laminates 7 forming the semi-stringers 2

are assembled over a bench and introduced in the bed plate of a thermo-forming machine. Control thermocouples are fitted and the tooling parts which may damage the machine membrane are coated with airweave (aerating fabric).

5 The hot forming cycle is obtained by applying heat and vacuum. In this way, formed laminates 7 are obtained forming semi-stringers (figure 4) over the thermo-forming tools 8; the stringer 2 is obtained by means of bonding the semi-stringers by couples (as shown in figure 5).

10 Due to the thermo-forming tool 8 geometry, the feet 3 of the stringers 2 are adapted to the coating shape of part 1, ascending and descending the slopes existing on it.

C - Assembly on the turning frame

15 The stringers 2 are removed from the forming tools 8 and then introduced in the angle pieces 4, 4' previously fitted in the turning frame.

20 The angle pieces 4, 4' are tightened by sections and a cradle with the already cured base skin (part 1) on which the reinforcements have been fitted is placed below the frame.

 The stringers 2 are turned over part 1, for which the frame is provided with movement and mechanical and optical positioning means permitting to obtain the desired accuracy.

25 Then, the frame is removed and the tightness is assured to prevent resin of the composite material from flowing outwardly and formation of the vacuum bag is started.

 The positioning tolerances of the parts between each other and of the latter with the tools are related to the thickness and geometrical characteristics thereof.

30 D - Autoclave process preparation

 Once the green parts or stringers 2 and their tools 8 have been positioned over the cured base skin (part 1), the vacuum bag is prepared, for which three layers of different materials will be used. In the last layer, a series of
35 perforations will be made to locate valves which will extract air from the bag, hence obtaining the required

vacuum. The bag will remain sealed to the tool, preventing loses thanks to a strip of mastic fitted around the perimeter. To assure tightness, the bag will be tested once cold.

5 Re-usable bags of silicone, etc. may also be used.

E - Autoclave curing

After preparing the vacuum bag, the assembly is loaded over the autoclave support tool. This is hermetically closed and the corresponding curing cycle is carried out rating the value of the following essential parameters, depending on the characteristics of the material and the part:

- Pressure: 5.95 - 10.5 kg/cm².
- Temperature: up to 190°C according to the material.
- Rate of heating: 0.5 - 2°C/min.

15 Once the autoclave chamber reaches the environmental conditions of pressure and temperature, the already cured and perfectly consolidated material is removed. The parts initially in a pre-impregnation condition (stringers 2) are now perfectly adhered to the cured component (part 1) and in a condition to support the structural stresses for which they have been designed.

As already described in its different stages, in the process of the present invention, the key factor lies in retaining the resin flow of the composite material of the stiffener (stringer 2) during the curing process, for which the previously described gluing process is applied, in which the stringer 2 is confined between two steel, aluminium, pneumatic cushion angle pieces 4, 4' etc., like those shown in figure 2, the latter having a series of elastomeric components (elastomeric pipes 5, 5') which are those retaining the resin flow.

The process of the invention is applicable for different thickness (3.5 - 16 mm for the core and 2 to 8 mm for the stiffener foot, spar and/or stringer) and for different laminates 7. The dimensions are very variable, both in height and length. Until now, parts reaching a 17 m

length with suitable tooling have been developed.

The basic features of the invention have been remarked above, although, as will be understood, it will possible to make amendments of certain details of the manufacturing process developed by the applicant. For this reason, it is intended that the scope of the invention is limited only by the contents of the attached claims.

WHAT IS CLAIMED IS:

1. A process for manufacturing pre-cured composite material parts with uncured applied stiffeners, wherein at least two parts manufactured in composite materials are structurally bonded, of which a first part, called base part or support, is in a cured condition; and a second part, called stiffener, is in an uncured condition and wherein the bonding of both parts is carried out by means of a structural adhesive sheet, so that the second part is compacted against the first part, with adequate crosslinking of the resin of its composite material and so strongly adhered to the skin of the first part that the adequate resistance of the adhesive sheet is assured, characterised in that it comprises the following steps:

a) laminating superimposed layers of composite material in a pre-impregnated condition, so that the fibre orientation adapts to the structural requirements of the part to be obtained, producing from the resulting laminates the base part on the one hand, and on the other hand, an assembly of basic stacks destined to form the second part;

b) curing the base part obtained in step a) ;

c) assembling the laminate destined to form the second part over a bench and introducing the assembly in a thermo-forming machine with a thermo-forming tool and carrying out a hot forming cycle by applying heat and vacuum, hence obtaining halves of the part which is then bonded to each other by couples to form the complete second part;

d) removing the second part from the forming tool and introducing it in angle pieces previously fitted over a turning frame, applying a structural adhesive sheet to the second part in the area where this should remain bonded to the base part, tightening the angle pieces by sections and placing a cradle with the already cured base part beneath the turning frame, turning the second part until leaving it

over the base part, removing the turning frame and assuring tightness to prevent resin of the composite material of the second part from flowing outwardly;

e) once the second part has been positioned over the already cured base part, closing the assembly inside a vacuum bag and sealing the latter by means of a mastic strip fitted around its perimeter; and

f) loading the closed assembly inside the vacuum bag over an autoclave support tool, closing the latter hermetically, carrying out a curing cycle of the second part under pressure and temperature and then allowing the autoclave chamber to reach pressure and room temperature conditions again, after which the assembly formed by the previously cured base part and a second now cured part which is strongly adhered to said base part, is removed from the autoclave.

2. A process according to claim 1, characterised in that a base part and two or more second parts are bonded to obtain a finished pre-cured part.

3. A process according to claims 1 or 2, characterised in that if it is desired to laminate several parts at the same time, the laminate obtained in step a) is subjected to later cutting into the several separate parts required.

4. A process according to any one of claims 1 to 3, characterised in that the laminate is obtained in a flat or curved shape, with or without changes of thickness, both transverse and longitudinal.

5. A process according to any one of claims 1 to 4, characterised in that the curing of step f) is carried out at a pressure of 5.95 - 10.5 kg/cm² and at a temperature of up to 190°C, depending on the used composite material, with a heating rate of 0.5°C/min - 2°C/min.

6. A process according to any one of claims 1 to 5, characterised in that parts applicable in aerospace, marine and land vehicle structures and controls are obtained, as well as in industrial machinery and equipment.

7. A process according to any one of claims 1 to 6, characterised in that the base part consists of the skin of an aircraft wing, a stabiliser or any other component needing to be stiffened to comply with its structural function.

8. A process according to any one of claims 1 to 7, characterised in that the second part has an L- or T-shaped transverse section

9. A process according to any one of claims 1 to 8, characterised in that the second part has a thickness from 2 to 8 mm in the foot and from 3.5 to 16 mm in the core and the final pre-cured part consisting of the base part and the second part has a length of up to 17 m.

10. A process according to any one of claims 1 to 9, characterised in that a re-usable bag of silicone or similar material is used as a vacuum bag for step e).

11. A process according to any one of claims 1 to 9, characterised in that the vacuum bag is formed in step e) by means of three layers of different materials, in the last of which a series of perforations are made to receive valves to extract air from the bag and hence obtaining the required vacuum.

12. A process according to any one of claims 1 to 11, characterised in that the composite material consists of fibres and resins selected from fiberglass, carbon fibre, Kevlar fibre, boron fibre, epoxy resin, thermoplastic resin and other heat-stable resins.

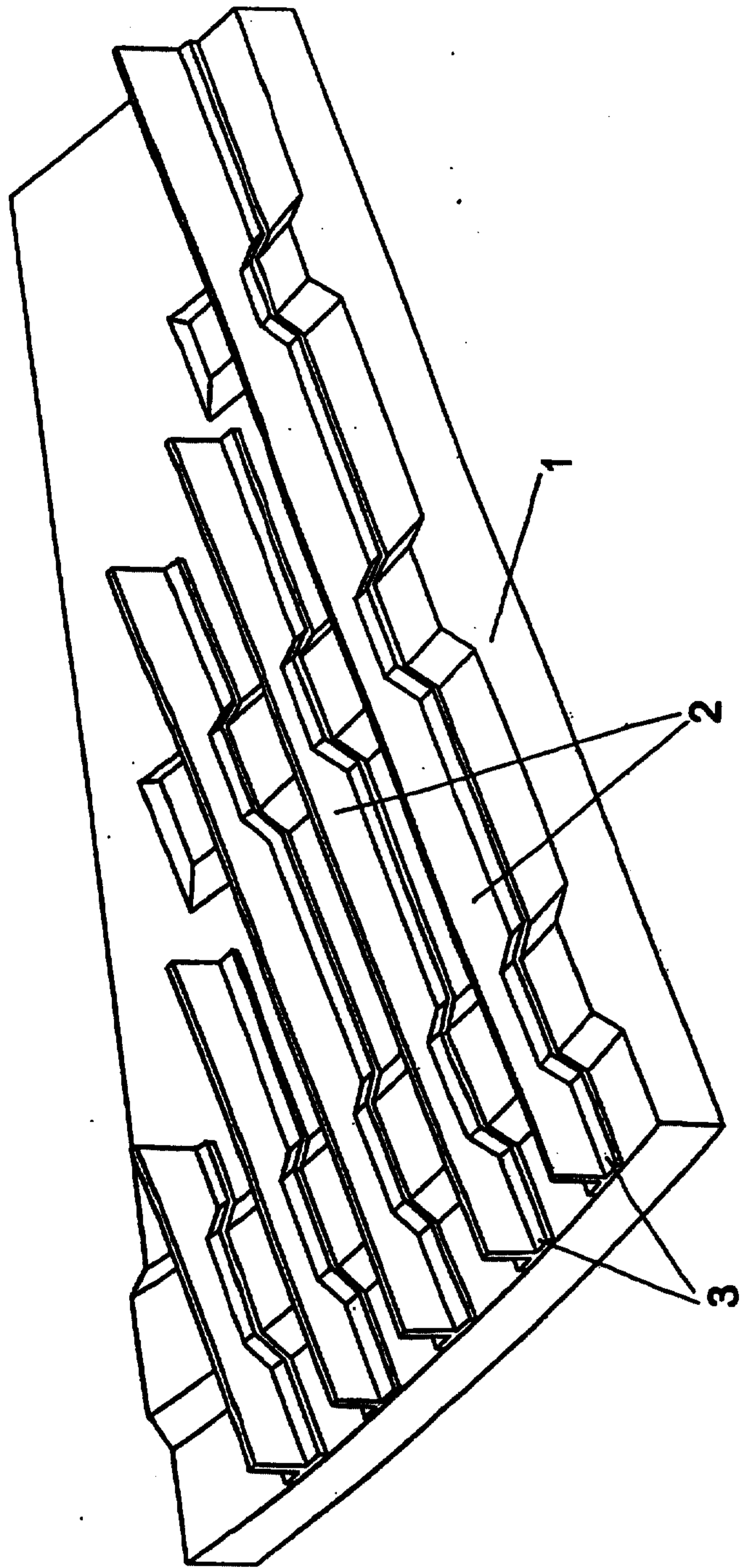

FIG. 1

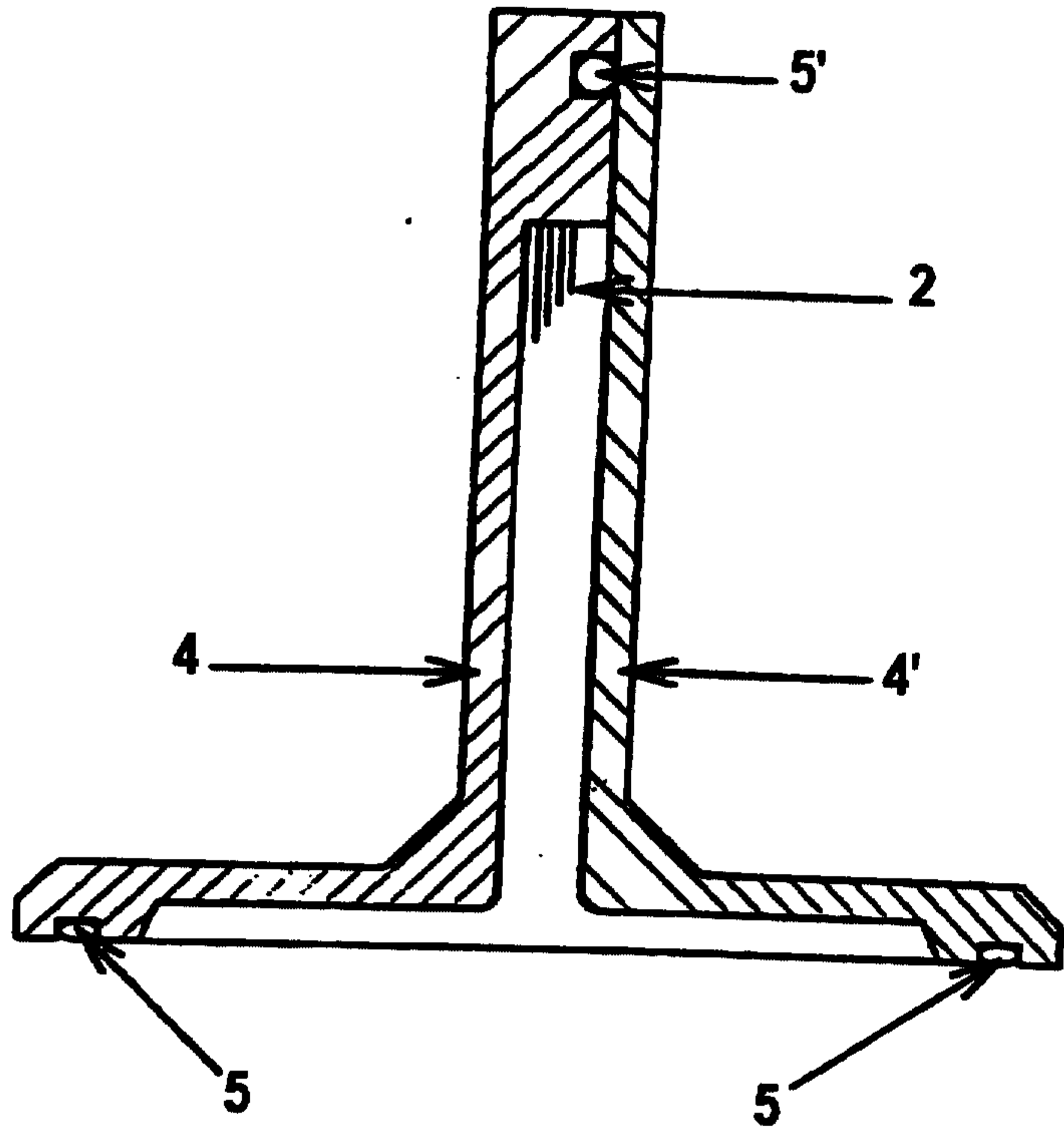

FIG. 2

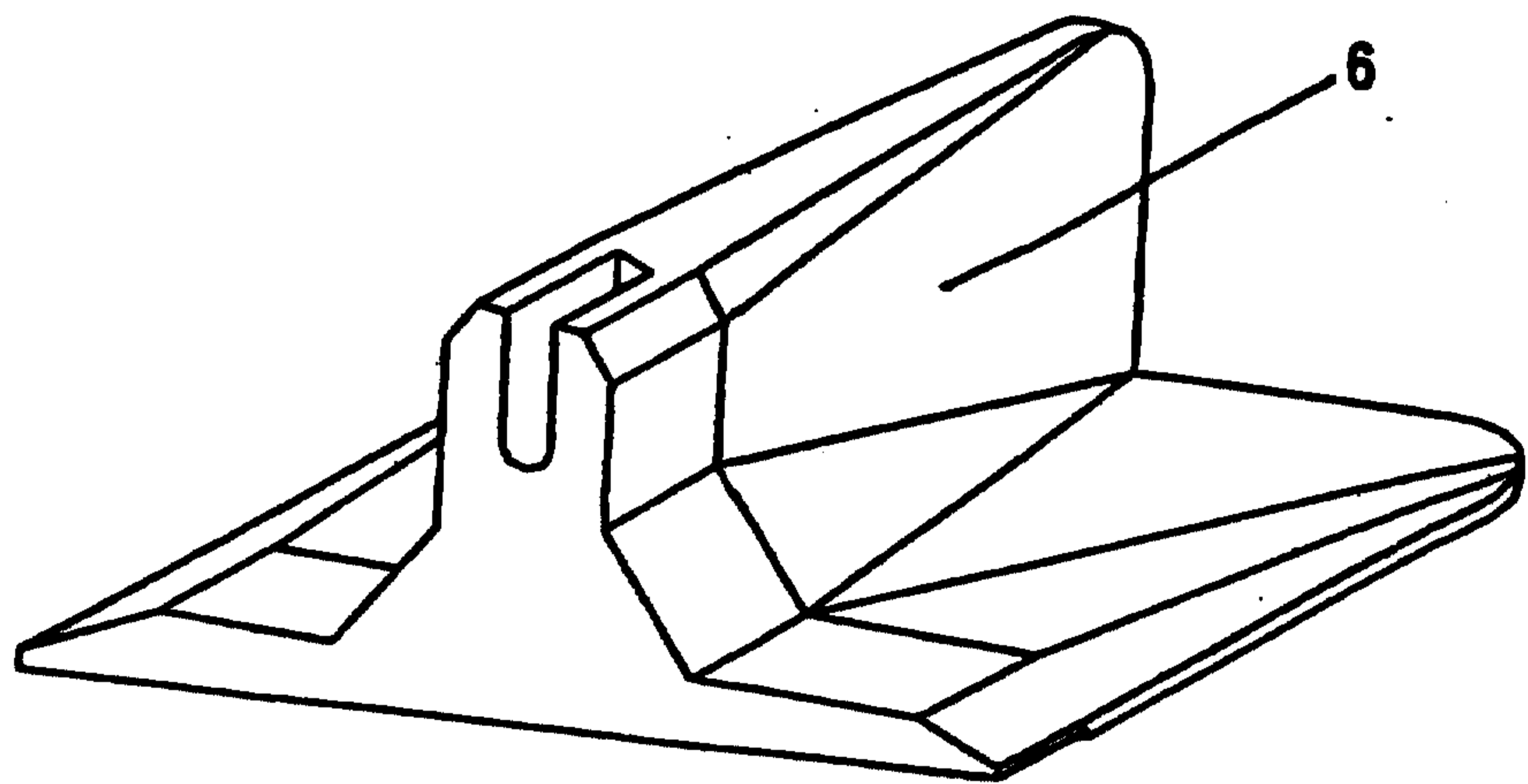

FIG. 3

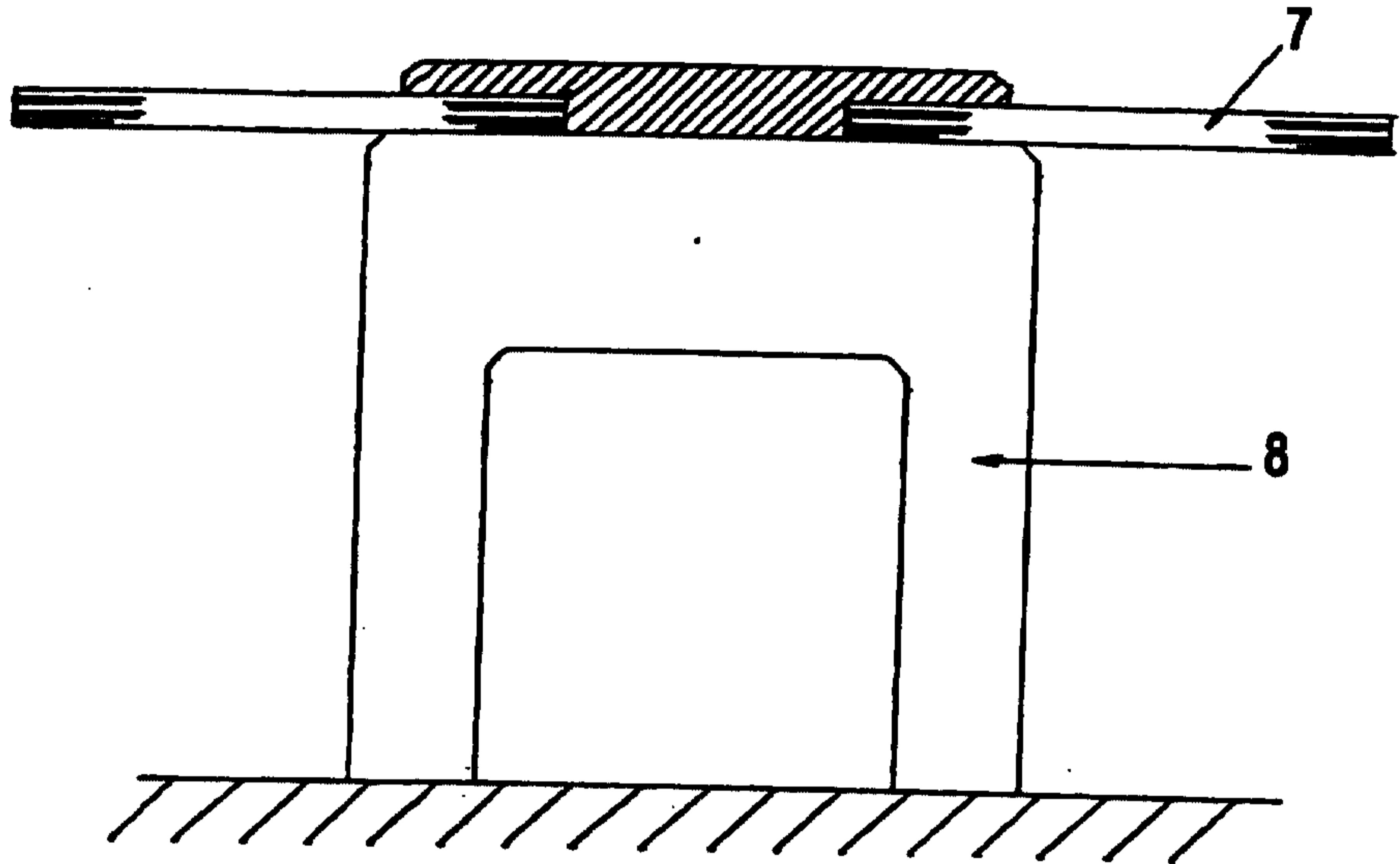

FIG. 4

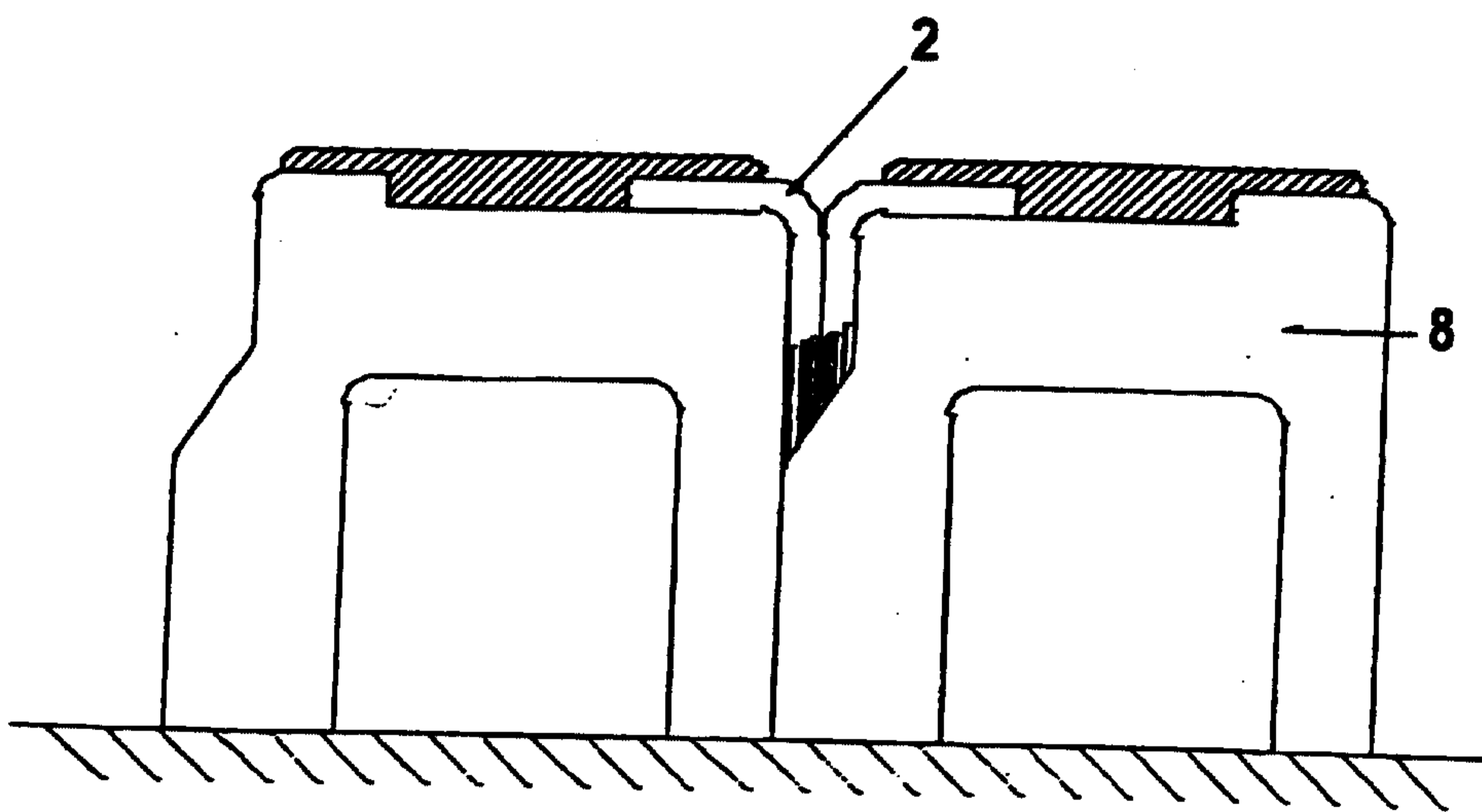

FIG. 5

