

(19) World Intellectual Property Organization  
International Bureau



(43) International Publication Date  
25 November 2004 (25.11.2004)

PCT

(10) International Publication Number  
WO 2004/102049 A1

- (51) International Patent Classification<sup>7</sup>: **F16K 17/34**
- (74) Agent: **FRENCH, Timothy, A.**; Fish & Richardson P.C.,  
225 Franklin Street, Boston, MA 02110-2804 (US).
- (21) International Application Number:  
PCT/US2004/013993
- (81) Designated States (*unless otherwise indicated, for every kind of national protection available*): AE, AG, AL, AM, AT, AU, AZ, BA, BB, BG, BR, BW, BY, BZ, CA, CH, CN, CO, CR, CU, CZ, DE, DK, DM, DZ, EC, EE, EG, ES, FI, GB, GD, GE, GH, GM, HR, HU, ID, IL, IN, IS, JP, KE, KG, KP, KR, KZ, LC, LK, LR, LS, LT, LU, LV, MA, MD, MG, MK, MN, MW, MX, MZ, NA, NI, NO, NZ, OM, PG, PH, PL, PT, RO, RU, SC, SD, SE, SG, SK, SL, SY, TJ, TM, TN, TR, TT, TZ, UA, UG, UZ, VC, VN, YU, ZA, ZM, ZW.
- (22) International Filing Date: 5 May 2004 (05.05.2004)
- (25) Filing Language: English
- (26) Publication Language: English
- (30) Priority Data:  
10/430,654 6 May 2003 (06.05.2003) US
- (84) Designated States (*unless otherwise indicated, for every kind of regional protection available*): ARIPO (BW, GH, GM, KE, LS, MW, MZ, NA, SD, SL, SZ, TZ, UG, ZM, ZW), Eurasian (AM, AZ, BY, KG, KZ, MD, RU, TJ, TM), European (AT, BE, BG, CH, CY, CZ, DE, DK, EE, ES, FI, FR, GB, GR, HU, IE, IT, LU, MC, NL, PL, PT, RO, SE, SI, SK, TR), OAPI (BF, BJ, CF, CG, CI, CM, GA, GN, GQ, GW, ML, MR, NE, SN, TD, TG).
- (63) Related by continuation (CON) or continuation-in-part (CIP) to earlier application:  
US 10/430,654 (CIP)  
Filed on 6 May 2003 (06.05.2003)
- (71) Applicant (*for all designated States except US*): **JOHNSON DESIGN LLC** [US/US]; 6361 Yarrow Drive, Suite F, Carlsbad, CA (US).
- (72) Inventor; and
- (75) Inventor/Applicant (*for US only*): **DWIGHT, N., Johnson** [US/US]; 6327 Chorlito Drive, Carlsbad, CA 92009 (US).

**Published:**  
— with international search report

*For two-letter codes and other abbreviations, refer to the "Guidance Notes on Codes and Abbreviations" appearing at the beginning of each regular issue of the PCT Gazette.*

(54) Title: EXCESS FLOW SHUTOFF

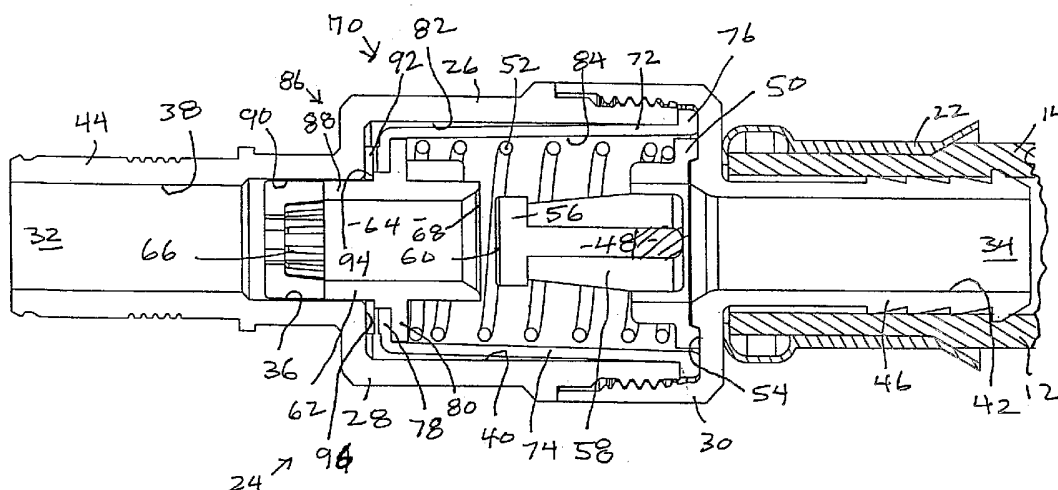

(57) Abstract: A flexible connector (12) incorporates an excess flow shutoff (24) at its inlet (14) to prevent uncontrolled flow in the event of a failure such as rupture or separation of the connector. A shutoff sleeve (62) moves in a body (26) between an upstream, open position and a downstream, closed position. A spring biases the shutoff sleeve toward the open position. The sleeve includes a flow metering passage (64), and a pressure drop resulting from excess flow through the passage moves the sleeve to the closed position against a shutoff seat (60). A time delay is provided by a damping system (70) including a variable volume damper chamber (82) defined in part by a flexible bladder (72). Upstream pressure is communicated to the damper chamber by a restricted flow passage provided by metal to metal contact of a washer (92) against a body surface (96).

WO 2004/102049 A1

## EXCESS FLOW SHUTOFF

### Field of the Invention

[0001] The present invention relates to an excess flow shutoff for household water systems and the like.

### Description of the Prior Art

[0002] In household and other water systems, flexible connectors can be used to supply water to appliances such as toilets and faucets. Flexible connectors are available in many styles and lengths and are convenient to install. Installation can be further simplified with a universal hookup kit as disclosed in U.S. patent 5,375,887. Because of their convenience and low cost, flexible connectors are now widely used.

[0003] A disadvantage of flexible connector installations is that they can fail when the connector ruptures or separates. Should this occur, a large uncontrolled water flow results. This poses a serious threat of flooding and expensive water damage.

[0004] The need to prevent uncontrolled excess flow has been recognized in applications other than water systems. U.S. patent 5,215,178 discloses a rapid acting safety valve for preventing problems resulting from failure of a pressurized hydraulic line. If excess flow occurs due to hydraulic line failure, a spool 50 moves against the force of a spring 45 to close against a seat 69.

[0005] A rapid acting shutoff such as disclosed in U.S. patent 5,215,178 would be subject to premature nuisance shutoff if used to supply a flexible connector in a household water system. In a water system, air can be present in the piping system. A flow surge can occur when air flows through a faucet or toilet fill valve supplied from a flexible connector. A rapid acting shutoff could close in response to such a surge, disabling the supplied

appliance until the shutoff condition is corrected by reopening the shutoff device.

[0006] U. S. patent No. 3,735,777 recognizes this problem and discloses a shutoff having a damping capability for preventing rapid closure. Damping is effected by entry of O-ring 31 on valve member 25 into cylinder 22 as the valve member 25 moves toward the closed position. A restricted passage 32 permits only gradual movement of the valve body 25 into the cylinder 22.

[0007] The shutoff disclosed in U. S. patent No. 3,735,777 is complex and expensive and requires many parts. In addition, that design can be subject to seal drag, especially under long term, hot water conditions. In the shutoff of U. S. patent No. 3,735,777 the damping effect is achieved during valve closing motion.

### **Summary of the Invention**

[0008] It would be desirable to provide an excess flow shutoff wherein a delay period resulting from a damping effect precedes an abrupt, essentially valve closing. A primary object of the present invention is to provide an improved excess flow shutoff. Other objects are to provide an excess flow shutoff for avoiding water damage resulting from flexible connector failure in a water system; to provide an excess flow shutoff that is not subject to premature nuisance shutoff resulting from transient elevated flows due to air in the water system; to provide an excess flow shutoff that operates quickly from open to closed positions following a damper controlled delay period; and to provide an excess flow shutoff that is reliable and rugged, simple and inexpensive.

[0009] In brief, in accordance with the invention there is provided an excess flow shutoff including a body having a flow path with an inlet passage, a enlarged central cavity, and an outlet extending from the cavity. A shutoff seat is provided in the flow path between the inlet passage and the outlet. A shutoff sleeve is mounted in the body for movement between an upstream open position and a downstream closed position and has an upstream stem portion slideably received in the inlet passage with a

clearance defining a damper flow path. The shutoff sleeve has a downstream closure portion engageable with the shutoff seat to block flow through the flow passage in the closed position. A spring in the cavity biases the shutoff sleeve toward the open position. A flow metering passage through the shutoff sleeve develops a flow responsive pressure drop urging the shutoff sleeve against the biasing force of the spring from the open position to the closed position in response to excess liquid flow. A variable volume damper chamber is defined in part by a resilient damper bladder. A restricted passage extends from the damper flow path to the damper chamber for increasing the pressure in the damper chamber in response to increasing flow through the flow path.

### **Brief Description of the Drawing**

[0010] The present invention together with the above and other objects and advantages may best be understood from the following detailed description of the preferred embodiment of the invention illustrated in the drawings, wherein:

[0011] FIG. 1 is an isometric side view of a flexible connector including an excess flow shutoff constructed in accordance with the present invention;

[0012] FIG. 2 is an enlarged, axial cross sectional view of the excess flow shutoff showing the excess flow shutoff in the open position;

[0013] FIG. 3 is a view like FIG. 2 showing the excess flow shutoff in the closed position; and

[0014] FIG. 4 is an exploded isometric view of the components of the excess flow shutoff.

### **Detailed Description of the Preferred Embodiment**

[0015] Having reference now to the drawing, and initially to FIG. 1 there is illustrated a flexible connector generally designated as 10 suitable for connecting an appliance such as a faucet or toilet tank fill valve to a

household or other water system. The flexible connector 10 includes a length of flexible conduit 12 extending between an inlet 14 and an outlet 16. The flexible conduit 12 can be made of any conventional material such as an ethylene propylene plastic covered with a braided nylon. At the outlet 16, the conduit 12 is attached by a crimped ferrule 18 to a conventional coupling nut fitting 20 designed to mate with the inlet of an appliance such as a faucet or toilet. At the inlet 14, the conduit 12 is attached by a crimped ferrule 22 to an excess flow shutoff generally designated as 24 and constructed in accordance with the principles of the present invention.

[0016] Flexible connectors such as the connector 10 can fail. Typical failure modes are rupture of the wall of the conduit 12 and separation of the conduit from one of the crimped ferrules 18 or 22. Such a failure presents a problem because of the damage that can result from large uncontrolled flow into a home or other structure. This problem is solved in accordance with the present invention by supplying water to the flexible connector 10 through the excess flow shutoff 24.

[0017] In the embodiment of the invention illustrated in the drawings, the excess flow shutoff 24 is incorporated permanently into the inlet 14 of the flexible connector 10. The advantage of this arrangement is that the installer need only use the single flexible connector 10 and thereby obtains the protection provided by the included excess flow shutoff. However, if desired, the excess flow shutoff can be provided as a separate unit for attachment, for example, with conventional fittings between a water system and the inlet of a conventional flexible connector or other connector device. As another alternative, the excess flow shutoff could be incorporated into a water supply fitting such as an angle stop.

[0018] The construction of the excess flow shutoff 24 is seen in FIGS. 2-4. The excess flow shutoff 24 has a body 26 including a base 28 and a cap 30 threaded onto the base 28. Water enters the body 26 through an inlet 32 and leaves the body 26 through an outlet 34. A flow path 36 through the body 26 from the inlet 32 to the outlet 34 includes an inlet passage 38, an enlarged central cavity 40 and an outlet passage 42. In the illustrated embodiment of the invention, the inlet passage 38 extends through a fitting or terminal portion 44 of the base 28 of body 26. The terminal portion 44

may be a terminal of a plumbing hookup kit as described in U.S. patent 5,375,887, incorporated herein by reference. That patent may be consulted for a further description of the terminal portion 44. Alternatively, the inlet passage could be associated with any conventional fitting assembly, such as a fitting mating with a conventional water supply fitting such as an angle stop.

[0019] In the illustrated embodiment of the invention, the outlet passage 42 extends through a barbed shank portion 46 of the cap portion 30 of body 26. The inlet 14 of the conduit 12 is attached to the barbed shank portion 46 by the crimped ferrule 22. Alternatively, the outlet passage 42 could be associated with a conventional fitting such as a threaded shank for connection to other devices.

[0020] A shutoff member 48 mounted within the cavity 40 includes a base 50 held by a spring 52 against a downstream cavity wall 54. Alternatively, base 50 can be fixedly secured to wall 54. A head portion 56 held upstream from the base 50 by a pedestal 58 includes a shutoff seat 60. In the open position of the excess flow shutoff seen in FIG. 2, water can flow around the shutoff seat 60, along the pedestal 58 and through the base 50 into the outlet passage 42.

[0021] A shutoff sleeve 62 is movable in the body 26 between an upstream, open position seen in FIG. 2 and a downstream, closed position seen in FIG. 3. In the open position of FIG. 2 water flows through an axial flow metering passage 64 extending through the shutoff sleeve 62. A strainer 66 is formed as an integral part of the sleeve 62. The spring 52 normally holds the shutoff sleeve 62 in the open position. A pressure drop resulting from flow through the flow metering passage 64 moves the shutoff sleeve 62 to the closed position as described below in connection with the operation of the excess flow shutoff 24. In the closed position of FIG. 3, an annular closure surface or portion 68 of the shutoff sleeve 62 engages the shutoff seat 60 of the shutoff member 48 to block flow through the body 26 of the excess flow shutoff 24.

[0022] A damping assembly generally designated as 70 prevents premature nuisance operation of the excess flow shutoff 24 in response to

transient flow peaks such as could result from air in the water system. The damping assembly 70 includes a flexible bladder 72 preferably made of rubber or other elastomer. The bladder 72 includes a generally cylindrical body portion 74, a radially outwardly directed sealing flange 76 at its downstream end and a radially inwardly directed mounting flange 78 at its upstream end. The bladder 72 is mounted in the cavity 40, with the integral sealing flange 76 captured between the base 28 and cap 30 to seal the body 26 without the need for a separate seal member. The mounting flange 78 engages the upstream side of a flange 80 of the shutoff sleeve 62.

[0023] The cylindrical body 74 of the bladder 72 encloses and surrounds the spring 52, and as seen in FIG. 2 normally is spaced radially outward from the outside diameter of the spring 52. The bladder cooperates with the body 26 to define a variable volume damper chamber 82 located radially outside the bladder 72. The bladder 72 divides the cavity 40 of the body 26 into two portions, namely a flow region 84 within the bladder 72 and the damper chamber 82 outside of the bladder 72.

[0024] Flow through the flow metering passage 64 results in a drop in pressure between the upstream and downstream ends of the flow metering passage 64. The flow region 84 is subjected to the lower, downstream pressure. The inlet passage 38 is subjected to the higher, upstream pressure. The high pressure inlet passage 38 communicates with the damper chamber 82 through a restricted flow passage 86. The shutoff sleeve 62 includes a stem portion 88 slideable in an enlarged diameter segment 90 of the inlet passage 38. A radial clearance between nose 88 and the wall of passage segment 90 permits flow from the inlet passage 38 toward the damper chamber 82.

[0025] A washer 92 is captured between an upstream facing shoulder 94 of the shutoff sleeve 62 and a downstream facing end wall 96 of the cavity 40. The spring 52 normally clamps the upstream face of the washer 92 in face to face abutment against the wall 96. These interfacing surfaces define the restricted flow passage 86. Various features such as grooves, abutments or other surface configurations can be used to permit a controlled restricted flow across these interfacing surfaces. A preferred approach is to form both surface of metal by making both the base 28 and the washer 92 of

metal. The resulting metal to metal contact provides a controlled leakage path having the desired restricted flow characteristic.

[0026] In operation, the flexible connector 10 is installed into a household or similar water system by connecting the fitting 20 to a appliance such as a faucet or a toilet tank fill valve and by connecting the terminal or other fitting 44 to an angle stop or other water supply connection. The spring 52 applies a biasing force in the upstream direction to the shutoff sleeve 62, holding it in the open position of FIG. 2, and clamping the washer 92 against the wall 96 of the cavity 40. In this normal, open position (FIG. 2), water can flow from the water system, through the excess flow shutoff 24 and conduit 12 to the connected appliance.

[0027] Pressurized water is then applied to the connector 10, for example by opening a valve included in the angle stop of the water system. When the connected appliance uses water, water flows through the connector 10 and through the excess flow shutoff 24. The maximum flow rate into a typical appliance in a typical water system is about two gallons per minute. With this normal flow rate, the pressure drop across the shutoff sleeve 62 develops a force tending to move the shutoff sleeve away from the open position, but this force is less than the force applied in the opening direction by the spring 52. As a result, during normal operation of the connected appliance, the shutoff sleeve remains in the open position of FIG. 2.

[0028] An excess flow condition can result, for example, from rupture of the conduit 12 of connector 10 or separation of the conduit 12 from a fitting at one of the crimped ferrules 18 and 22. The increased flow rate causes the excess flow shutoff 24 to close, preventing sustained uncontrolled flow, flooding and water damage. If flow increases to a sustained elevated rate such as more than three gallons per minute, the pressure drop across the flow metering passage 64 in the shutoff sleeve increases to a value that results in a closing force greater than the opening force applied by the spring 52.

[0029] The damping assembly 70 provides a time delay in closing operation and the excess flow shutoff 24 does not move or close

immediately as a result of a flow rate increase. The upstream pressure in the inlet passage 38 is communicated to the damper chamber 82 through the restricted flow passage 86. When pressure increases due to an excess flow rate, the initial effect is to gradually increase the volume of the damper chamber 82 as water gradually enters the damper chamber 82 through the restricted flow passage 86. As a result, the volume of the damper chamber 82 increases and the body 74 of the bladder 72 gradually collapses against the outside diameter of the spring 52 as seen in FIG. 3. If the excess flow is a transient event resulting for example from the flow of trapped air through the connected appliance, the flow rate returns to normal before the damper chamber reaches its maximum volume and the shutoff sleeve 62 does not move from its open position of FIG. 1.

[0030] If the excess flow continues, as occurs if the flexible connector 10 fails, the damper chamber 82 expands to its maximum volume with the bladder body portion 74 against the spring 52 as seen in FIG. 3. During expansion of the damper chamber 82, the pressures in the damper chamber 82 and in the flow region 84 within the bladder 72 are generally equalized by flexibility of the bladder 72. When the damper chamber 82 reaches its maximum volume, pressure in the damper chamber 82 increases as further bladder movement is blocked by contact against the spring 52. At this point, the shutoff sleeve 62 moves away from the open position of FIG. 2. The closure surface portion 68 approaches the shutoff seat 60 of the shutoff member 48, throttling flow between the closure portion 68 and the shutoff seat 60. An increasing pressure drop due to this throttling action cause the shutoff sleeve to move quickly to the closed position of FIG. 3.

[0031] The effect of the damping chamber 82 defined in part by the flexible bladder 72 in a moderate excess flow condition is to provide an initial time delay during which there is no movement of the shutoff sleeve 62. A transient excess flow does not cause sleeve motion during the damping delay period. If excess flow continues, at the end of the delay period, the shutoff sleeve 62 moves abruptly from the open to the closed position. Inlet pressure clamps the sleeve 62 closed until such time as the excess flow shutoff 24 is reset by removing inlet pressure after repair of the excess flow fault condition.

[0032] The use of a flexible bladder for the damper chamber avoids a seal drag problem that can occur with other damper systems. The strainer 66 blocks out an particles large enough to interfere with closing of the shutoff sleeve 62 against the shutoff seat 60. Closing speed of the shutoff sleeve 62 is moderated by the flow clearance between the nose 88 and the passage segment 90 in order to prevent a water hammer effect

[0033] While the present invention has been described with reference to the details of the embodiments of the invention shown in the drawing, these details are not intended to limit the scope of the invention as claimed in the appended claims.

## Claims

What is claimed is:

- 1           1.     An excess flow shutoff, comprising:  
2           a body;  
3           a shutoff sleeve mounted in the body for movement between an open  
4 position permitting flow through the body and a closed position limiting flow  
5 through the body; and  
6           a resilient damper bladder located within the body and defining a  
7 variable volume damper chamber such that movement of the bladder in  
8 response to an increase in the volume of the damper chamber provides a  
9 time delay in movement of the shutoff sleeve toward the closed position in  
10 response to flow rate increase.
  
- 1           2.     The excess flow shutoff of claim 1 wherein the body has a flow  
2 path including an inlet passage, and the shutoff sleeve has an upstream  
3 stem portion slideably received in the inlet passage with a clearance defining  
4 a damper flow path in fluid communication with the variable volume damper  
5 chamber.
  
- 1           3.     The excess flow shutoff of claim 2 further defining a restricted  
2 passage extending from the damper flow path to the damper chamber for  
3 increasing the pressure in the damper chamber in response to increasing  
4 flow through the flow path.
  
- 1           4.     The excess flow shutoff of claim 3 wherein the restricted  
2 passage is defined by an interface between a metal surface of the cavity and  
3 a metal washer.
  
- 1           5.     The excess flow shutoff of claim 4 wherein the metal washer is  
2 between the metal surface and the shutoff sleeve.
  
- 1           6.     The excess flow shutoff of any of the preceding claims further  
2 comprising a shutoff seat in the body.

1           7.     The excess flow shutoff of claim 6 wherein the shutoff sleeve  
2 includes a downstream closure portion engageable with the shutoff seat to  
3 limit flow through the main flow path in the closed position.

1           8.     The excess flow shutoff of claim 7 further comprising a shutoff  
2 member including the shutoff seat, said spring comprising a coil spring in  
3 compression between the shutoff member and the shutoff sleeve.

1           9.     The excess flow shutoff of claim 8 wherein the resilient damper  
2 bladder surrounds and encloses the spring.

1           10.    The excess flow shutoff of any of the preceding claims wherein  
2 the body defines an enlarged central cavity and an outlet extending from the  
3 cavity.

1           11.    The excess flow shutoff of claim 10 further comprising a spring  
2 located in the cavity biasing the shutoff sleeve toward the open position.

1           12.    The excess flow shutoff of any of claims 1-10 further  
2 comprising a spring biasing the shutoff sleeve toward the open position.

1           13.    The excess flow shutoff of claim 11 or 12 further comprising a  
2 flow metering passage through the shutoff sleeve for developing a flow  
3 responsive pressure drop urging the shutoff sleeve against the biasing force  
4 of the spring from the open position to the closed position in response to  
5 excess liquid flow.

1           14.    The excess flow shutoff of any of the preceding claims wherein  
2 the body includes a base portion and a cap, the resilient damper bladder  
3 including a flange portion clamped in sealing relation between the base  
4 portion and the cap.

1           15.    The excess flow shutoff of any of the preceding claims wherein  
2 the damper chamber is defined between an outside of the resilient damper  
3 bladder and a wall of the body.

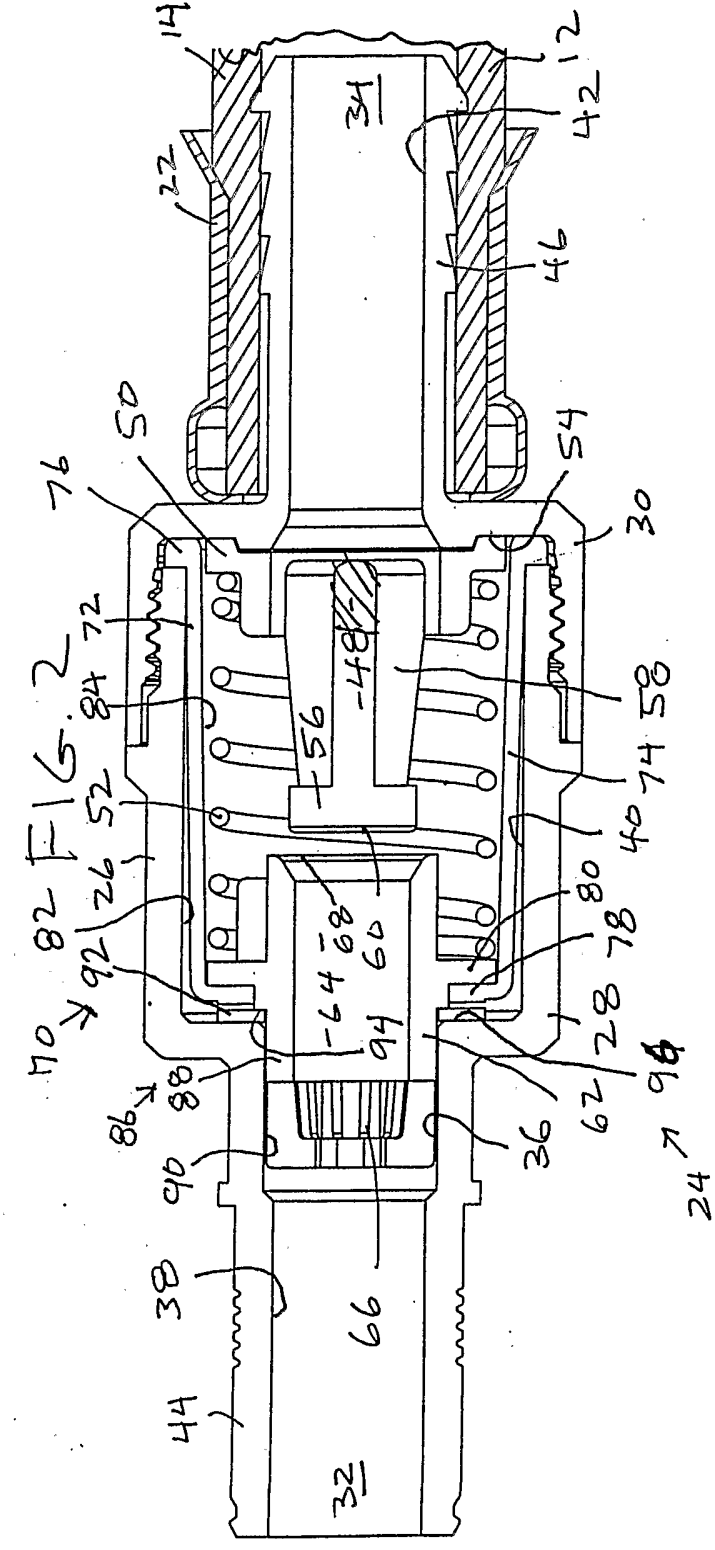
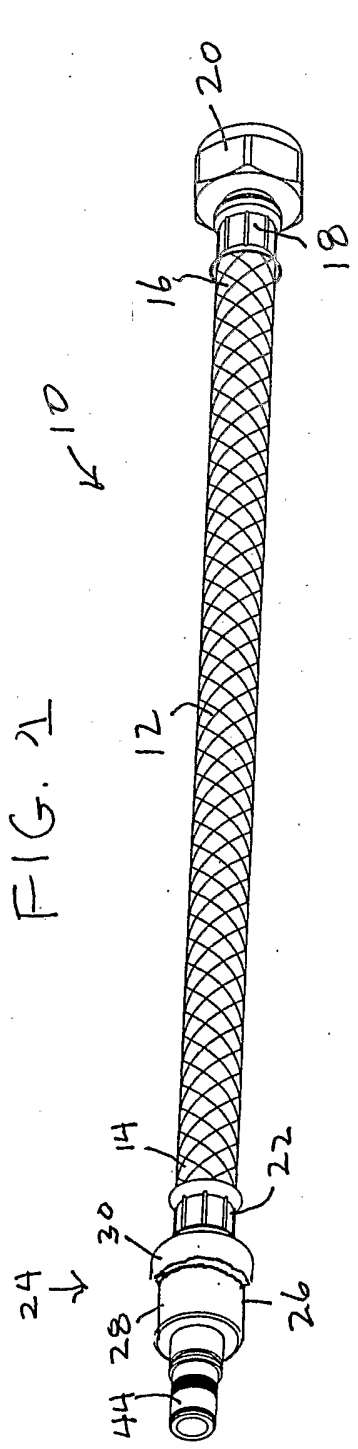

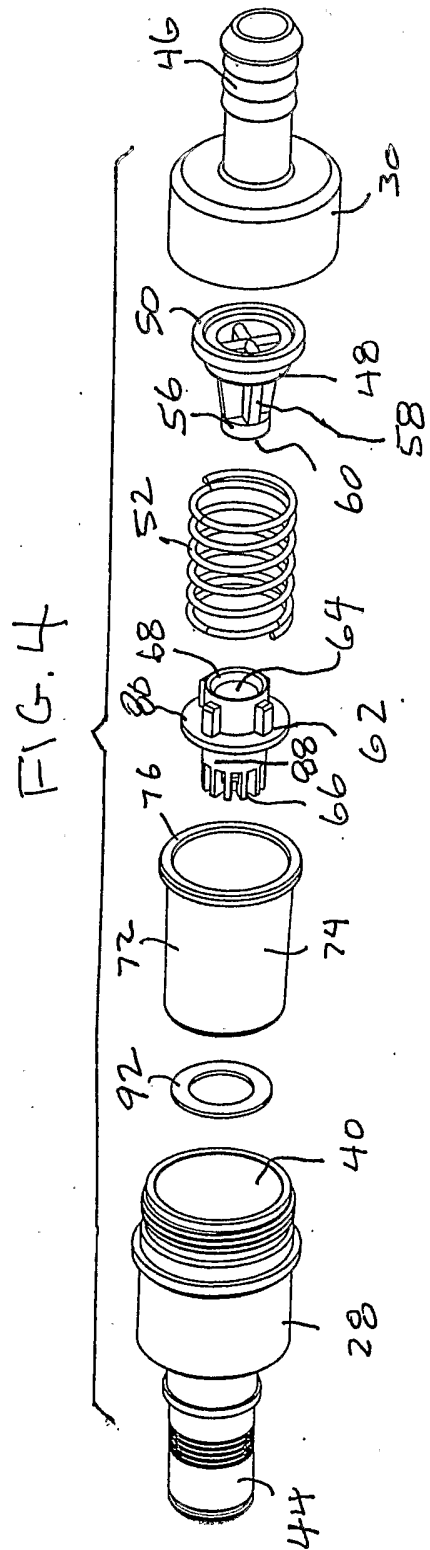
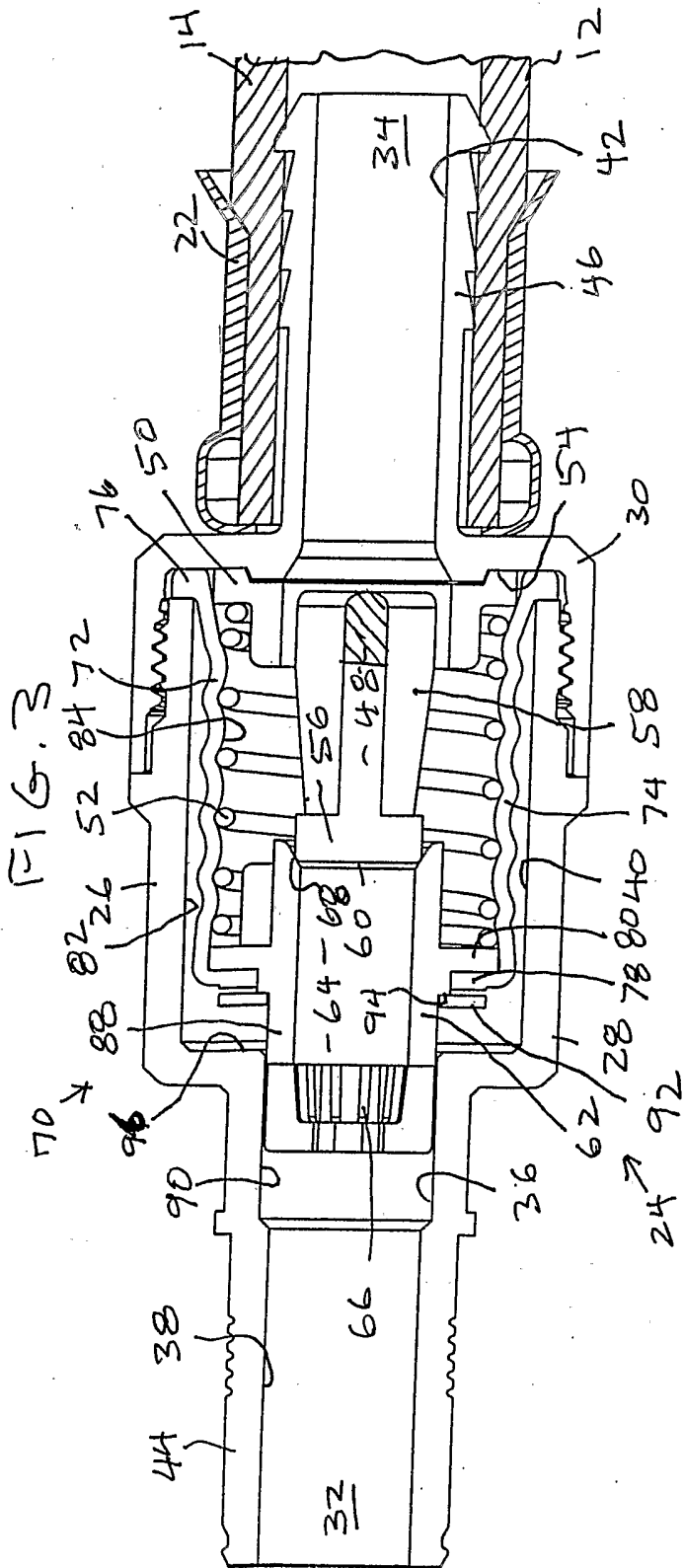

**INTERNATIONAL SEARCH REPORT**

International Application No  
PCT/US2004/013993

**A. CLASSIFICATION OF SUBJECT MATTER**  
IPC 7 F16K17/34

According to International Patent Classification (IPC) or to both national classification and IPC

**B. FIELDS SEARCHED**

Minimum documentation searched (classification system followed by classification symbols)  
IPC 7 F16K

Documentation searched other than minimum documentation to the extent that such documents are included in the fields searched

Electronic data base consulted during the international search (name of data base and, where practical, search terms used)

EPO-Internal

**C. DOCUMENTS CONSIDERED TO BE RELEVANT**

Category °	Citation of document, with indication, where appropriate, of the relevant passages	Relevant to claim No.
X	US 3 794 063 A (CARROLL M ET AL) 26 February 1974 (1974-02-26) column 2, line 32 - column 3, line 40; figures column 3, line 67 - column 3, line 8	1-3, 10-13,15
A	FR 2 298 755 A (NUSSBAUM & CO AG R) 20 August 1976 (1976-08-20) page 3, line 19 - page 5, line 16; figures 1-3	1-3,6-8, 10-15
A	FR 2 769 681 A (FAFNIR AIRINDEX) 16 April 1999 (1999-04-16) abstract; figure 1	1-3,6-8, 10-15

Further documents are listed in the continuation of box C.

Patent family members are listed in annex.

° Special categories of cited documents :

- \*A\* document defining the general state of the art which is not considered to be of particular relevance
- \*E\* earlier document but published on or after the international filing date
- \*L\* document which may throw doubts on priority claim(s) or which is cited to establish the publication date of another citation or other special reason (as specified)
- \*O\* document referring to an oral disclosure, use, exhibition or other means
- \*P\* document published prior to the international filing date but later than the priority date claimed

- \*T\* later document published after the international filing date or priority date and not in conflict with the application but cited to understand the principle or theory underlying the invention
- \*X\* document of particular relevance; the claimed invention cannot be considered novel or cannot be considered to involve an inventive step when the document is taken alone
- \*Y\* document of particular relevance; the claimed invention cannot be considered to involve an inventive step when the document is combined with one or more other such documents, such combination being obvious to a person skilled in the art.
- \*Z\* document member of the same patent family

Date of the actual completion of the international search

2 September 2004

Date of mailing of the international search report

09/09/2004

Name and mailing address of the ISA

European Patent Office, P.B. 5818 Patentlaan 2  
NL - 2280 HV Rijswijk  
Tel. (+31-70) 340-2040, Tx. 31 651 epo nl,  
Fax: (+31-70) 340-3016

Authorized officer

Christensen, J

**INTERNATIONAL SEARCH REPORT**

Information on patent family members

International Application No  
PCT/US2004/013993

Patent document cited in search report		Publication date	Patent family member(s)	Publication date
US 3794063	A	26-02-1974	CA 990523 A1	08-06-1976
			GB 1445898 A	11-08-1976
FR 2298755	A	20-08-1976	CH 576092 A5	31-05-1976
			AT 350863 B	25-06-1979
			AT 23776 A	15-11-1978
			AU 500299 B2	17-05-1979
			AU 1048876 A	28-07-1977
			DE 2601350 A1	29-07-1976
			FI 760139 A ,B,	23-07-1976
			FR 2298755 A1	20-08-1976
			JP 51099333 A	01-09-1976
			NL 7600604 A ,B,	26-07-1976
			NO 760178 A ,B,	23-07-1976
			SE 413269 B	12-05-1980
			SE 7600524 A	23-07-1976
FR 2769681	A	16-04-1999	FR 2769681 A1	16-04-1999