

(19) World Intellectual Property Organization
International Bureau



(43) International Publication Date
5 January 2012 (05.01.2012)

PCT

(10) International Publication Number
WO 2012/000983 AI

- (51) **International Patent Classification:**
H01F 27/36 (2006.01)
- (21) **International Application Number:**
PCT/EP201 1/060797
- (22) **International Filing Date:**
28 June 2011 (28.06.2011)
- (25) **Filing Language:** English
- (26) **Publication Language:** English
- (30) **Priority Data:**
10167483.6 28 June 2010 (28.06.2010) EP
- (71) **Applicant (for all designated States except US):** **ABB TECHNOLOGY AG** [CH/CH]; Affolternstrasse 44, CH-8050 Zurich (CH).
- (72) **Inventors; and**
- (75) **Inventors/ Applicants (for US only):** **MURILLO, Rafael** [ES/ES]; Madre Sacramento 53, 4A, E-50004 Zaragoza (ES). **ROY, Carlos** [ES/ES]; Santa Teresa de Jesus 9, E-50006 Zaragoza (ES). **SMAJIC, Jasmin** [BA/CH]; Dorfwiesenstrasse 22, CH-8165 Schofflisdorf (CH). **DONZEL, Lise** [CH/CH]; Landstrasse 82, CH-5430

Wettingen (CH). **TEPPER, Jens** [DE/DE]; Springstrasse 22, 59929 Brilon (DE). **LETOSA FLETA, Jesus** [ES/ES]; c/o Plablo Iglesias n°33, 8°B, E-50018 Zaragoza (ES). **USON, Antonio** [ES/ES]; Paseo de Sagasta2m 3°izda., E-50006 Zaragoza (ES). **VILLEN, Maria Teresa** [ES/ES]; c/o Viridiana, 11 3 izq., E-50019 Zaragoza (ES). **SAMPLON, Miguel** [ES/ES]; Paseo Teruel 19 5°, E-50004 Zaragoza (ES).

(74) **Agent: INGOLD, Mathias;** c/o ABB Schweiz AG, Intellectual Property CH-LI/IP, Brown Boveri Strasse 6, CH-5400 Baden (CH).

(81) **Designated States (unless otherwise indicated, for every kind of national protection available):** AE, AG, AL, AM, AO, AT, AU, AZ, BA, BB, BG, BH, BR, BW, BY, BZ, CA, CH, CL, CN, CO, CR, CU, CZ, DE, DK, DM, DO, DZ, EC, EE, EG, ES, FI, GB, GD, GE, GH, GM, GT, HN, HR, HU, ID, IL, IN, IS, JP, KE, KG, KM, KN, KP, KR, KZ, LA, LC, LK, LR, LS, LT, LU, LY, MA, MD, ME, MG, MK, MN, MW, MX, MY, MZ, NA, NG, NI, NO, NZ, OM, PE, PG, PH, PL, PT, RO, RS, RU, SC, SD, SE, SG, SK, SL, SM, ST, SV, SY, TH, TJ, TM, TN, TR, TT, TZ, UA, UG, US, UZ, VC, VN, ZA, ZM, ZW.

[Continued on next page]

(54) **Title:** TRANSFORMER WITH SHIELDING RINGS IN WINDINGS

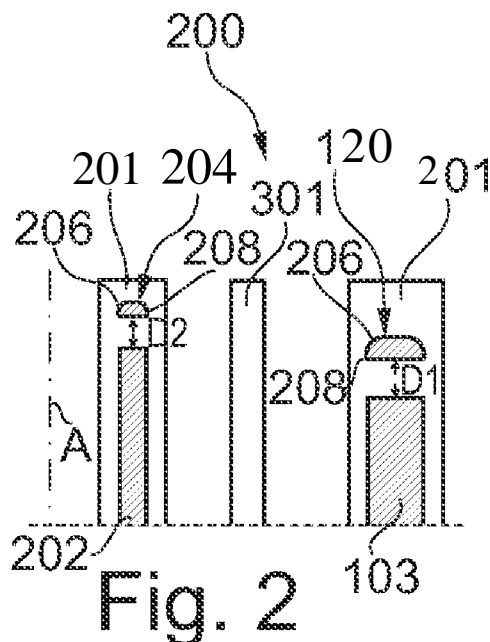

(57) **Abstract:** The invention relates to the shielding of windings of a transformer, in particular to a coil and electric shielding arrangement for a transformer, a transformer with the arrangement and a method of manufacturing a coil and electric shielding arrangement for a transformer. A coil and electric shielding arrangement (200) for a dry-type transformer is provided, wherein an electric shielding device (120, 204) is arranged at a distance (D1, D2) to a winding (103, 202) at an axial end (116, 118) of the winding (103, 202) perpendicular to a longitudinal axis (A) of the transformer and parallel to the top surface of a cylindrical-shaped coil which is wound by the winding (103, 202) around the axis (A) such that the electric shielding device (120, 204) covers the cross-section area of the winding (103, 202) perpendicular to the longitudinal axis (A). Another such electric shielding device (120, 204) may be arranged at the other axial end of the winding (103, 202). An insulation material (201) is attached to the winding (103, 202) and to the electric shielding device (120, 204) providing the distance (D1, D2) between the winding (103, 202) and the electric shielding device (120, 204) along the longitudinal axis (A) such that an environment of the winding (103, 202) is shielded against the electric field of the winding (103, 202). The winding (103, 202) and the electric shielding device (120, 204) are casted in a block which insulates the electric shielding device (120, 204) from the electric field of the winding (103, 202) by providing a distance between the winding (103, 202) and the electric shielding device (120, 204).

WO 2012/000983 AI

(84) **Designated States** (unless otherwise indicated, for every kind of regional protection available): ARIPO (BW, GH, GM, KE, LR, LS, MW, ML, NA, SD, SL, SZ, TZ, UG, ZM, ZW), Eurasian (AM, AZ, BY, KG, KZ, MD, RU, TJ, TM), European (AL, AT, BE, BG, CH, CY, CZ, DE, DK, EE, ES, FI, FR, GB, GR, HR, HU, IE, IS, IT, LT, LU, LV, MC, MK, MT, NL, NO, PL, PT, RO, RS, SE, SI, SK,

SM, TR), OAPI (BF, BJ, CF, CG, CI, CM, GA, GN, GQ, GW, ML, MR, NE, SN, TD, TG).

Published:

— with international search report (Art. 21(3))

DESCRIPTION

TRANSFORMER WITH SHIELDING RINGS IN WINDINGS

5

FIELD OF THE INVENTION

The invention relates to electric shielding of transformers. In particular, the invention relates to a coil and electric shielding arrangement for a transformer, a transformer with the arrangement, and the method of manufacturing a coil and electric shielding arrangement
10 for a transformer.

BACKGROUND OF THE INVENTION

Transformers may be widely used for low, medium, and high voltage applications.

15 Typically, in dry type transformers the high voltage to low voltage insulation is made by an air space, with or without solid barriers being the high voltage and low voltage coils being surrounded by solid insulation. The critical electric field in the air is found at the top and bottom edges of the windings.

20 SUMMARY OF THE INVENTION

It may be seen as an object of the invention to increase the dielectric strength of a transformer.

This object is achieved by a coil and electric shielding arrangement for a transformer, a
25 transformer with the arrangement, and a method of manufacturing a coil and electric shielding arrangement for a transformer according to the independent claims. Further embodiments are evident from the dependent claims.

According to one embodiment of the invention a coil and electric shielding arrangement
30 for a transformer is provided with a winding wound around a longitudinal axis of the transformer forming the coil or the cylindrical shaped coil, an electric shielding device

which is arranged at a distance to the winding at an axial end of the winding perpendicular to the longitudinal axis and parallel to the top surface of the coil which may be a cylindrical-shaped coil such that the electric shielding device covers the cross-section area of the winding perpendicular to the longitudinal axis, and an insulation material attached to the winding and to the electric shielding device providing the distance between the winding and the electric shielding device along the longitudinal axis such that an environment of the winding is shielded against the electric field of the winding, wherein the winding and the electric shielding device are casted in a block which insulates the electric shielding device from the electric field of the winding by providing a distance between the winding and the electric shielding device.

In other words, an electric shielding device, e.g. in form of an open ring, may be arranged at one axial end of the winding. Such an electric shielding device may also be arranged at another axial end of the winding. The electric shielding device(s) may in particular be arranged between the winding and the yokes of the winding, and may smooth the electric field generated by the winding to the outside of the winding. The winding may be a winding arrangement and may consist of more than one coil such as a high voltage coil and a low voltage coil. The electric shielding device thus may shield the electric fields of the high voltage winding or generated by the high voltage winding and of the low voltage winding or generated by the low voltage winding from each other, such that the electric field inside the windings is shielded as well as the electric field generated by the high voltage and low voltage windings to the environment of the high voltage and low voltage windings. The insulation material may surround or may be moulded to the winding and the electric shielding device(s). The winding and the electric shielding device(s) may be casted or encapsulated in a block.

Electric shielding devices may be located at a first end and at a second end of the winding only in a high voltage winding or both in a high voltage winding and a low voltage winding such that the electric field of the windings or generated by the windings is smoothed. The electric field within the solid insulation close to the electric shielding device, e.g. a shielding ring, may be smoothed. The sudden change in permittivity from the insulation material, which may be a resin, to air that may lead to a electric field distortion in the air may be smoothed by avoiding sharp edges in the areas close to the winding edges (close to the shielding rings) by rounding the edges of the insulation material e.g. the resin.

Thus the electric field of the windings or generated by the windings is smoothed by a combination of electric shielding rings plus rounded edges in the near area.

Such an arrangement with one or more electric shielding devices may improve the initial voltage distribution, when the transformer is subjected to any high voltage surge
5 such as a lightning impulse. With the above described arrangement an improvement of breakdown voltage between 25-30% compared to a transformer without the arrangement may be achieved. The transformer may be applicable at a 72.5 kV level or at a level below 72.5 kV or at a level above 72.5 kV. The transformer may be a dry-type transformer.

10 According to another embodiment of the invention the electric shielding device(s) comprise(s) first rounded edges not facing the winding and second rounded edges facing the winding, wherein the radius of the first rounded edges and the radius of the second rounded edges are adapted such that an electric shielding of the environment of the winding is provided by the electric shielding device.

15

The electric shielding device(s) with first and/or second rounded edges may improve the shielding capacity of the electric shielding device(s) such that the electric field of the winding or generated by the winding to the outside of the winding may be smoothed even better than by electric shielding device(s) without rounded edges.

20

According to another embodiment of the invention the first rounded edges have a radius of 5 to 20 mm, in particular 10 mm, and the second rounded edges have a radius of 2 to 5 mm, in particular 3 mm.

25 The inner radii of the second rounded edges close to the conductor or the winding may be smaller than the outer radii of the first rounded edges, for example 2 or 3 mm for the inner and between 5-20 mm for the outer radii. Electric shielding devices, for example with a rectangular bar with rounded edges (radii 3-5 mm), or with a rounded wire (radii 3-5 mm) may be manufactured. Thus a high voltage transformer may be effectively shielded.

30 The electric shielding device may be open in some point in order to avoid a close loop possibly evoking a short circuit. Electric shielding device(s) with rounded edges with the above mentioned radii may shield an electric field of the winding to the environment of the

winding more efficiently compared to other above mentioned radii or compared to electric shielding device(s) with non-rounded edges.

According to another embodiment of the invention the electric shielding device is
5 electrically connected to the winding.

The electric shielding device may be electrically connected to the winding at the beginning, and at any intermediate location of the winding or the electric shielding device may be electrically floating.

10

According to another embodiment of the invention the distance between the winding and the electric shielding device is between 5 and 40 mm.

With such a distance between 5 and 40 mm the shielding of the electric field of the
15 winding to the environment of the winding by the electric shielding device(s) may be optimized compared to other distances.

According to another embodiment of the invention the electric shielding device has an open ring shape or an annular shape.

20

An electric shielding device with an open ring shape avoids a close loop possibly evoking a short circuit, and may thus provide for an effective and optimized shielding of the electric field of the winding to the environment of the winding.

According to another embodiment of the invention the winding and the electric
25 shielding device are casted in a block which insulates the electric shielding device from the electric field of the winding by providing a distance of 5 to 40 mm between the winding and the electric shielding device. The casted block comprises rounded edges near the electric shielding device with radii corresponding to the radii of the first rounded edges of
30 the electric shielding device, in particular radii of 5 to 15 mm. The electric field generated by the windings is smoothed by a combination of the electric shielding device with the first rounded edges and the rounded edges of the cast block near the first rounded edges.

According to another embodiment of the invention the cross-section of the electric shielding device is selected from the group of polygonal cross-sections with rounded edges, of semi-elliptical like cross-sections, or of a circular cross-section.

5

The electric shielding device may have the form of a rounded wire with cross-sectional radii of 3-5 mm.

The above mentioned cross-sections of the electric shielding device, in particular the semi-elliptical like cross-section, may provide for a better and more efficient shielding of the electric field of the winding to the environment of the winding compared to other cross-sections of the electric shielding device.

10

According to another embodiment of the invention the electric shielding device comprises a non-conductive material frame covered by a layer of a conductive material.

15

The layer of conductive material may be much thinner than the material frame.

By providing an electric shielding device with a non-conductive material frame covered by a layer of a conductive material the shielding capacity and/or shielding characteristic of the electric shielding device concerning the shielding of an electric field of the winding to the environment of the winding may be improved or optimized compared to an electric shielding device without such a non-conductive material frame covered by a layer of a conductive material. The much thinner conductive material compared to the material frame thickness may further improve the shielding characteristic of the electric shielding device.

20

According to another embodiment of the invention the winding is a high voltage winding and/or a low voltage winding, wherein the electric shielding device covers the cross-section area of the high voltage winding and/or the low voltage winding perpendicular to the longitudinal axis.

25

The electric shielding device thus may shield the electric fields of the high voltage winding or generated by the high voltage winding and of the low voltage winding or generated by the low voltage winding from each other, such that the electric field inside the

30

windings is shielded as well as the electric field generated by the high voltage and low voltage windings to the environment of the high voltage and low voltage windings.

According to another embodiment of the invention the cross-section of the attached
5 insulation material comprises rounded edges.

The radius of the rounded edges may have the same size as the radius of the first rounded and/or second rounded edges. Thus the electric field within the solid insulation close to the electric shielding device, may be smoothed. The sudden change in permittivity
10 from the insulation material, which may be a resin, to air that may lead to a electric field distortion in the air may be smoothed by avoiding sharp edges in the areas close to the winding edges (close to the shielding rings) by rounding the edges of the insulation material e.g. the resin. Thus the electric field of the windings or generated by the windings is smoothed by a combination of electric shielding rings plus rounded edges in the near
15 area.

According to another embodiment of the invention the arrangement further comprises a low voltage winding with a second shielding device and an insulating barrier. The insulating barrier is provided between the high voltage winding and the low voltage
20 winding and is adapted to stop charge avalanche between the high voltage winding and the low voltage winding.

The inclusion of insulating barriers between two parts under voltage may increase the electric field and thus the voltage they can support without having any discharge. The
25 effect of the barriers may be explained with their property of stopping the free charges which can initiate a discharge, limiting the path, the velocity and the energy of the charges. A given distance of air may withstand more voltage if the total space of air is split to smaller sections. The barriers may have the form of a cylinder and may be made of glass fibre composite film which may have a thickness of 3 mm and may be adapted to act as an
30 electric barrier and as a mechanical support. Additional insulation may be obtained with same turns of insulating film which may have a thickness of 1 mm. The number of barriers may depend on the total air distance between the high voltage and low voltage windings, ranging from 3-6, or even more for high air distances. The air spaces may be between 20-

50 mm and the barriers may be uniformly distributed between high voltage and low voltage windings such that the air space is similar.

In order to minimize the electric field, typically for high voltage windings, the electric shielding ring may have a few more or few less millimetres than the inner high voltage winding diameter (e.g. 4 mm). In order to minimize the electric field, the typically low voltage winding (shielding ring) will have a few more or few less millimetres than the outer low voltage winding diameter (e.g. 4 mm).

If the windings are rounded (with a diameter between 5 and 20 mm) the electric field is smooth and the distance between both windings could be reduced. The shape may be achieved during manufacturing or mechanized after the winding is done. Regarding the thickness of the solid insulation around the windings it may be around 10 mm in both high voltage and low voltage windings except on the ends of the high voltage and low voltage windings, where it may be around 20 mm.

Any sharp edge, even if it is an insulation material, may increase the electric field in the given configuration. This effect may appear in the edges at the ends of the windings in a transformer, and it may be even worse because of a uniformity in the electric field in this area. An electric shielding device with rounded edges may smooth the electric field inside the windings, meaning between high voltage and low voltage windings, and in order to have the same effect in the air close to the ends of the windings, the epoxy resin may have rounded edges with a approximately the same radius of the first rounded edges for example 10 mm.

According to another embodiment of the invention a transformer is provided with an arrangement of anyone of the above-mentioned embodiments, at least two limbs, a yoke connecting the at least two limbs, and a clamp attached at the yoke and stabilizing the yoke. The winding is arranged around at least one of the at least two limbs.

The above and below mentioned electric shielding arrangement is applicable to dry transformers with a voltage level above 70kV effectively shielding the dry transformer from the electric field generated by the winding of the dry transformer. Thus a dry transformer with HV winding designed as HV disc winding with a voltage level of 70kV and above may be built as compact as a dry transformer with a lower voltage level. There may be higher field strength in the critical region between the HV winding and the LV

winding and/or the yoke and particularly higher field peaks at the HV disc winding and the edges of the LV winding and/or the yoke compared to a dry transformer with a voltage level below 70 kV requiring a higher dielectric strength. This required higher dielectric strength may be provided by the electric shielding device or electric shielding devices
5 which may homogenize the electric field to the ground by a multi-part shielding of the high voltage and/or low voltage windings. Thus parts of the transformer such as the yoke are prevented from overheating or losing the required mechanical strength due to discharges of the electric field to the edges of the yoke by the electric shielding device. The electric shielding device may increase the breakdown voltage and may lead to an improvement of
10 shielding between HV and LV windings of the transformer coil and the yoke compared to a transformer with HV and/or LV windings without an electric shielding device.

According to another embodiment of the invention the transformer further comprises a second electric shielding device which is arranged at the yoke between the yoke and a
15 winding of the transformer and is adapted for shielding the yoke from an electric field of the winding. The transformer further comprises an electric shielding element which is arranged at the clamp between the clamp and the winding of the transformer and which is adapted for shielding the clamp from an electric field of the winding.

20 In other words, a cover may be arranged at the yoke facing the windings of the transformer and thereby shielding the yoke from an electric field of the windings. The second electric shielding device may act as an electrostatic shield or as a protective shield in order to shield the sharp edges of the yoke itself and all other edges related to the yoke such as edges of yoke laminations, so smoothing the electric field of the transformer with
25 respect to the yoke. This shielding cover is kept bare, not covered by any insulation film. The shielding cover may be insulated according to another embodiment of the invention. The yoke is adapted for connecting at least two limbs. More than one yoke may be provided. The winding may be arranged around at least one of the at least two limbs. The above and below mentioned electric shielding arrangement is applicable to dry
30 transformers with a voltage level above 70kV effectively shielding the yoke of the dry transformer from the electric field generated by the winding of the dry transformer. Thus a dry transformer with HV winding designed as HV disc winding with a voltage level of 70kV and above may be built as compact as a dry transformer with a lower voltage level.

There may be higher field strength in the critical region between the HV winding and the yoke and particularly higher field peaks at the HV disc winding and the edges of the yoke compared to a dry transformer with a voltage level below 70 kV requiring a higher dielectric strength. This required higher dielectric strength may be provided by the second electric shielding device or second electric shielding devices which may homogenize the electric field to the ground by a multi-part shielding of the yoke. Thus the yoke is prevented from overheating or losing its required mechanical strength due to discharges of the electric field to the edges of the yoke by the second electric shielding device.

The second electric shielding device may increase the breakdown voltage and may lead to an improvement of shielding between winding of the transformer coil and the yoke compared to a yoke without a second electric shielding device.

According to another embodiment of the invention the second electric shielding device has a shape corresponding to the shape of the yoke such that the yoke is covered by the second electric shielding device. The shape may be partly cylindrical or oval layer like or may be any shape which is adjusted to the edges.

According to another embodiment of the invention the second electric shielding device comprises a layer shape adapted to avoid sharp edges.

According to another embodiment of the invention the second electric shielding device comprises a conductive material.

According to another embodiment of the invention the second electric shielding device comprises a thin rectangular piece of one of aluminium and copper and may be ground connected. According to another embodiment of the invention the second electric shielding device is connected to the metallic structure of the transformer (the clamps).

The second electric shielding device may comprise a mixture of aluminium and copper. The second electric shielding device may comprise any other conductive material such as carbon steel or non-magnetic steel, and/or may comprise semiconductive material, since semiconductive material would also smooth the electric field. According to another embodiment of the invention a dielectric shielding of the yoke from an electric field of the winding is provided by the second electric shielding device, which may be a copper sheet or copper foil, and/or an insulating layer applied at the yoke, the insulating layer possibly having a high epsilon, for example an epsilon of 10. Thus the electric field at the yoke may be smoothed.

According to another embodiment of the invention the yoke is a split yoke, comprising a first yoke part and a second yoke part, wherein the second electric shielding device comprises a first electric shielding element and a second electric shielding element. The first electric shielding element is arranged at the first yoke part between the first yoke part and the winding of the transformer. The second electric shielding element is arranged at the second yoke part between the second yoke part and the winding of the transformer. The first electric shielding element is adapted for shielding the first yoke part from an electric field of the winding, and the second electric shielding element is adapted for shielding the second yoke part from an electric field of the winding.

In other words a yoke may be split in two halves, a first yoke part, and a second yoke part. A first and second electric shielding element, possibly in form of covers, may be arranged at the first and second yoke parts facing the windings of the transformer and thereby shielding the first and second yoke parts from an electric field of the windings. The first and second electric shielding elements may act as electrostatic shields or as protective shields in order to shield the sharp edges of the first and second yoke parts themselves and all other edges related to the first and second yoke parts such as edges of first and second yoke laminations, so smoothing the electric field of the transformer with respect to the first and second yoke parts. This shielding covers may be kept bare, not covered by any insulation film. The shielding covers may be insulated according to another embodiment of the invention. The first and second yoke parts are adapted for connecting at least two limbs. More than one first and second yoke parts may be provided. The winding may be arranged around at least one of the at least two limbs. A yoke cooling duct may be present between the first and the second yoke part for cooling the transformer by cooling agents such as oil or air or water. According to an exemplary embodiment of the invention the cooling agent is air.

The electric shielding element for the clamp may be a cover that may be placed on a clamp facing the winding, and the cover may act as an electrostatic shield or as a protective shield in order to shield the sharp edges of the clamp itself and all other metallic edges related to the clamp, so smoothing the electric field of the transformer with respect to the clamps. This shielding cover is kept bare, not covered by any insulation film. The shielding cover may be insulated according to another embodiment of the invention. The clamp is adapted for holding together or mechanically fixing or stabilizing a yoke of the transformer

to the coil(s) of the transformer. The electric shielding element may cover the clamp and/or may have a vat- or trough-like form covering the clamp.

The above mentioned electric shielding element is applicable to dry transformers with a voltage level above 70kV effectively shielding the clamp of the dry transformer from the electric field generated by the winding of the dry transformer. Thus a dry transformer with
5 HV winding designed as HV disc winding with a voltage level of 70kV and above may be built as compact as a dry transformer with a lower voltage level. There may be higher field strength in the critical region between the HV winding and the clamp and particularly higher field peaks at the HV disc winding and the edges of the clamp compared to a dry
10 transformer with a voltage level below 70 kV requiring a higher dielectric strength. This required higher dielectric strength may be provided by the electric shielding element which may homogenize the electric field to the ground such that the clamp is prevented from overheating or losing its required mechanical strength due to discharges of the electric field to the edges of the clamp by the electric shielding element.

15 The electric shielding element may comprise a material selected from the group consisting of steel, and aluminium, and generally any conducting material with stabilizing mechanical properties.

The electric shielding element may increase the breakdown voltage and may lead to a 25% improvement of shielding between winding of the transformer coil and the clamps
20 compared to clamps without an electric shielding element according to impulse voltage tests.

The clamp may have rounded edges forming a rounded clamp that may have the function of the electric shielding element, shielding the clamp from an electric field generated by the winding or windings of the transformer.

25 According to another embodiment of the invention the electric shielding element comprises rounded edges.

Such an electric shielding element with rounded edges may smooth an electric field of the winding of a transformer with respect to the transformer clamp by avoiding field peaks or discharges at edges of the clamp, thus preventing the clamp from overheating or losing
30 its required mechanical strength.

According to another embodiment of the invention a method of manufacturing a coil and electric shielding arrangement for a transformer is provided, comprising the steps of:

Winding a winding of the transformer around a longitudinal axis of the transformer forming the coil which may be a cylindrical-shaped coil, arranging an electric shielding device at a distance to the winding at an axial end of the winding perpendicular to the longitudinal axis and parallel to the top surface of the coil such that the electric shielding
5 device covers the cross-section area of the winding perpendicular to the longitudinal axis, attaching an insulation material to the winding and to the electric shielding device providing the distance between the winding and the electric shielding device along the longitudinal axis.

10 These and other aspects of the present invention will become apparent from and elucidated with reference to the embodiments described hereinafter.

BRIEF DESCRIPTION OF THE DRAWINGS

The subject-matter of the invention will be explained in more detail in the following
15 text with reference to exemplary embodiments which are illustrated in the attached drawings.

Fig. 1 schematically shows a cross-sectional view of a transformer with a coil and electric shielding arrangement according to an embodiment of the invention.

20

Fig. 2 schematically shows a cross-sectional view of a coil and electric shielding arrangement for a transformer with a low voltage winding and a high voltage winding according to an embodiment of the invention.

25 Fig. 3 schematically shows a cross-sectional view of a coil and electric shielding arrangement for a transformer with a low voltage winding and a high voltage winding according to another embodiment of the invention.

30 Fig. 4 schematically shows a cross-sectional view of a coil and electric shielding arrangement for a transformer with a low voltage winding and a high voltage winding according to another embodiment of the invention.

Fig. 5 schematically shows a cross-sectional view of an electric shielding device according to another embodiment of the invention.

Fig. 6 schematically shows a cross-sectional view of a coil and electric shielding
5 arrangement for a transformer with a second electric shielding device for shielding a yoke of the transformer and an electric shielding element for shielding a clamp if the transformer according to another embodiment of the invention.

Fig. 7 schematically shows a flow chart of a method of manufacturing a coil and electric
10 shielding arrangement for a transformer.

The reference signs used in the drawings, and their meanings, are listed in summary form in a list of reference signs. In principle, identical parts are provided with the same reference signs in the figures.

15

DETAILED DESCRIPTION OF EXEMPLARY EMBODIMENTS

Fig. 1 schematically shows a view of a transformer 101 with a coil and electric shielding arrangement 200 for each phase of the transformer 101 with windings 103, 202 each wound around a longitudinal axis A of the transformer 101 forming coils which may
20 be cylindrical-shaped coils, an electric shielding device 120, 204 which is arranged at a distance to the winding 103, 202 at an axial end 116, 118 of the winding 103, 202 perpendicular to the longitudinal axis A and parallel to the top surface of the coils such that the electric shielding device 120, 204 covers the cross-section area of the winding 103, 202 perpendicular to the longitudinal axis A, and an insulation material attached to the winding
25 103, 202 and to the electric shielding device 120, 204 providing a distance between the winding 103, 202 and the electric shielding device 120, 204 along the longitudinal axis A such that an environment of the winding 103, 202 is shielded against the electric field of the winding 103, 202 (see also Fig. 2 to Fig. 4). Two yokes 109 connect the three core limbs 113 of the transformer 101, each yoke 109 being mechanically stabilized by two
30 clamps 102. The windings 103, 202 are arranged around each core limb 113. The electric shielding device 120, 204 may improve the initial voltage distribution, if the transformer 101 is subjected to any high frequency voltage surge such as a lightning impulse.

A first electric shielding device 120 may be arranged at a first end 116 of the winding 103, 202 and/or at a second end 118 of the winding 103, 202. A first electric shielding device 120 may be arranged at a first end 116 and/or at a second end 118 of a high voltage winding 103, and a second electric shielding device 204 may be arranged at a first end 116
5 and/or at a second end 118 of a low voltage winding 202. The high voltage winding 103 and/or the low voltage winding 202 may be a foil winding 103, 202.

The transformer 101 for example a dry-type transformer 101 having the above described coil and electric shielding arrangement 200, is applicable at voltage level of 72.5 kV and at a voltage level above.

10

Fig. 2 schematically shows a cross-sectional view of one of the coil and electric shielding arrangements 200 shown in Fig.1 with a low voltage winding 202 and a high voltage winding 103. An insulation material 201 is attached to the high voltage winding 103 and the first electric shielding device 120, wherein the first electric shielding device
15 120 is arranged at a distance D1 to the high voltage winding 103 which may be between 15 to 40 mm. The insulation material 201 is attached as well to the low voltage winding 202 and the second electric shielding device 204, wherein a distance D2 between the low voltage winding 202 and the second electric shielding device 204 of about 5 to 40 mm is provided. The coil and electric shielding arrangement 200 provides for a shielding of an
20 electric field generated by the high voltage winding 103 and by the low voltage winding 202 to the environment of the high voltage winding 103 and the low voltage winding 202 and for a shielding between the high voltage winding 103 and the low voltage winding 202. The first electric shielding device 120 and the second electric shielding device 204 comprise first rounded edges 206 not facing the windings 103, 202 and second rounded
25 edges 208 facing the windings 103, 202. The first rounded edges 206 may have a radius of 5-20 mm, and particularly of 10 mm, and the second rounded edges 208 may have a radius of 2-5 mm, and particularly 3 mm. The radius of the first rounded edges 206 and the radius of the second rounded edges 208 are adapted such that an electric shielding of the environment of the winding 103, 202 is provided by the electric shielding device 120, 204.
30 An insulating barrier 301 is provided between the high voltage winding 103 and the low voltage winding 202 in a direction parallel to the axis A and is adapted to stop charge avalanche between the high voltage winding 103 and the low voltage winding 202. The

insulation material 201 is for example an epoxy resin. The high voltage winding 103 and/or the low voltage winding 202 may be a foil winding 103, 202.

Fig. 3 schematically shows a cross-sectional view of the coil and electric shielding arrangement 200 of Fig. 2, with the difference, that the low voltage winding 202 is not shielded by a second electric shielding device. There are three insulating barriers 301 arranged between the high voltage winding 103 and the low voltage winding 202 to stop charge avalanche between the high voltage winding 103 and the low voltage winding 202. The cross-section of the attached insulation material 201 of the high voltage winding 103 and the low voltage winding 202 comprises rounded edges 401. The radius of the rounded edges 401 may have the same size as a radius of the first rounded edges 206 of Fig. 2, if the embodiments of Fig. 2 and Fig. 4 are combined.

Fig. 4 schematically shows a cross-sectional view of the winding 103, 202 and the electric shielding device arrangement 200 of Fig. 2 with the difference, that neither the low voltage winding 202 nor the high voltage winding 103 is shielded by a first electric shielding device or a second electric shielding device. The cross-section of the attached insulation material 201 of the high voltage winding 103 and the low voltage winding 202 comprises rounded edges 401. The radius of the rounded edges 401 may have the same size as a radius of the first rounded edges 206 of Fig. 2, if the embodiments of Fig. 2 and Fig. 4 are combined. Fig. 4 comprises six insulating barriers 301 between the high voltage winding 103 and the low voltage winding 202 stop charge avalanche between the high voltage winding 103 and the low voltage winding 202.

Fig. 5 schematically shows a cross-sectional view of an electric shielding device 120, 204, which may have an open ring form. The cross-section of the electric shielding device 120, 204 is a rectangular bar cross-section with first rounded edges 206 with a radius of 10 mm and second rounded edges 208 of a radius of 3 mm and a thickness T1, T2 of approximately 15 mm. The electric shielding device 120, 204 may be a first electric shielding device 120 or a second electric shielding device 204, or both. The first rounded edges 206 may have a radius of 5-10 mm, and the second rounded edges 208 may have a radius of 2-5 mm. The electric shielding device may have a cross-section of a rounded wire with radii of 3-5 mm or a cross-section selected from the group of polygonal cross-sections

with rounded edges 206, 208, or semi-elliptical like cross-sections, or of a circular cross-section according to further embodiments of the invention (partly shown in Fig. 5).

Fig. 6 schematically shows a view of the coil and electric shielding arrangement 200 for the transformer 101 of Fig. 1 with a second electric shielding device 112 which is arranged at the yoke 109 between the yoke 109 and a winding 103 of the transformer 101 and is adapted for shielding the yoke 109 from an electric field of the winding 103. An electric shielding element 100 is arranged at the clamp 102 between the clamp 102 and the winding 103 of the transformer 101 and is adapted for shielding the clamp 102 from an electric field of the winding 103.

The yoke 109, 124, 126 connects limbs 113. The second electric shielding device 112 is arranged at the yoke 109, 124, 126 covering the yoke 109 between the yoke 109 and a winding 103 of the transformer 101. The second electric shielding device 112 is adapted for shielding the yoke 109, 124, 126 from an electric field of the winding 103.

The second electric shielding device 112 may be a rounded cover or an electrostatic shield being placed onto the yoke 109, 124, 126 in an area facing the winding 103 of the transformer 101 and is adapted to shield the sharp edges of the yoke 109, 124, 126 and thus smoothing the electric field of the transformer 101. The second electric shielding device 112 may be covered with an insulation film.

The second electric shielding device 112 may be adapted to shield the yoke 109, 124, 126 from a winding 103 of the transformer 101, when the arrangement is mounted to the transformer 101, thus smoothing an electric field between the windings 103 and the yoke 109, 124, 126 of the transformer 101.

The second electric shielding device 112 may have a cylindrical or an oval layer shape or a shape corresponding to the shape of the yoke 109, 124, 126 such that the yoke 109, 124, 126 is covered by the second electric shielding device 112. The second electric shielding device 112 may further comprise a layer shape adapted to avoid sharp edges.

The second electric shielding device 112 may have a conductive material and may be a thin rectangular piece of aluminium or copper or a mixture thereof or may have a semiconductive material, and may be ground connected by a ground connecting device 114.

The ground connecting device 114 is adapted to ground connect the second electric shielding device 112 to ground potential.

The second electric shielding device 112 may comprise an insulating film covering the second electric shielding device 112 in order to avoid a short circuit between yoke steel plates that would lead to higher limb 113 losses.

5 The cover with an insulating material or film of the second electric shielding device 112 may increase the electric field that the second electric shielding device 112 can withstand without the development of a discharge. The insulating film may be a semitransparent insulating film.

10 The second electric shielding device 112 may comprise a first electric shielding element part and a second electric shielding element part which are separate from each other, meaning that the second electric shielding device 112 may be separated in several parts.

The transformer 101 is adapted for electrically shielding the windings 103, which may be high voltage or low voltage windings 103, from the yoke 109, 124, 126.

The transformer 101 of Fig. 6 is applicable at a 72.5 kV level and at a level higher than a 72.5 kV level.

15 The clamp 102, 130, 132 is attached at the yoke 109, 124, 126, and stabilizes the yoke 109, 124, 126 of the transformer 101, and an electric shielding element 100, 140, 142 is arranged at the clamp 102, 130, 132 between the yoke 109, 124, 126 and a winding 103 of the transformer 101. The electric shielding element 100, 140, 142 is adapted for shielding the clamp 102, 130, 132 from an electric field of the winding 103. The clamp 102, 130, 20 132 is adapted for holding together or mechanically fixing the yoke 109, 124, 126 of the transformer 101. The yoke 109, 124, 126 connects at least two limbs 113 of the transformer 101. The electric shielding element 100, 140, 142 may comprise rounded edges 105, 106.

The electric shielding element 100, 140, 142 may project over the clamp edges 104.

25 The transformer 101 comprises at least two limbs 113, in particular three limbs 113, each comprising a first limb end 120 and a second limb end 122. A winding 103 is arranged around at least one of the at least two limbs 113, in particular a winding 103 is arranged at three limbs 113. A first yoke 109, 124 connects the three limbs 113 at the first limb ends 120. A second yoke 109, 126 connects the three limbs 113 at the second limb ends 122. First clamps 102, 130 are attached at the first yoke 109, 124 to stabilize the first 30 yoke 109, 124, and second clamps 102, 132 are attached at the second yoke 109, 124 to stabilize the second yoke 109, 126. First electric shielding elements 100, 140 are arranged at the first clamps 102, 130 between the first yoke 109, 126 and three windings 103 each of

the windings 103 arranged around each of the three limbs 113. Second electric shielding elements 100, 142 are arranged at the second clamps 102, 132 between the second yoke 109, 126 and the three windings 103.

5 First rounded edges 105 are arranged at a longitudinal side 150 of the clamp 102, 130, 132 facing the windings 103 of the transformer 101, wherein the windings 103 may be high voltage or low voltage windings. The longitudinal side 150 may be horizontal, and parallel to the yoke 109, 124, 126 limb 113 connecting side and perpendicular to the limbs 113 as indicated in Fig. 1. The first rounded edges 105 may arranged at clamp edges 104 which may be metallic clamp edges 104 related to the clamp 102, 130, 132.

10 The electric shielding element 100, 140, 142 acts as an electrostatic shield to shield the sharp clamp edges 104 itself and all other metallic clamp edges 104 related to the clamp 102, 130, 132, thus smoothing the electric field of the transformer 101.

15 Second rounded edges 106 are arranged at the first end 107 and at the second end 108 of the electric shielding element 100, 140, 142 at a transverse side 152 of the clamp 102, 130, 132. The transverse side 152 may be horizontal, perpendicular to the longitudinal side 150 and to a vertical side parallel to the limbs 113.

The first or second rounded edges 105, 106 may have a radius of 5-45 mm, in particular 30 mm.

20 The first rounded edges 105 have a different radius at a first region 110 at a yoke 109, 109, 124, 126 of the transformer 101 then at a second region 111 that is not at the yoke 109, 124, 126. The electric shielding element 100, 140, 142 may be grounded by being connected to the clamp 102, 130, 132, for example by being welded to the clamp 102, 130, 132.

25 The first rounded edges 105 may have a length of 1/8 of a circumference of a sphere defined by the radius of the first rounded edges 105 or in other words the first rounded edges 105 may have a length of 1/8 of a sphere.

30 The electric shielding element 100, 140, 142 is arranged on all clamps 102, 130, 132 of the transformer 101, wherein the transformer 101 is adapted for electrically shielding the windings 103 which may be high voltage windings 103 or low voltage windings 103, or both, to the clamp 102, 130, 132. The transformer 101 may be a dry type transformer 101 .

The embodiments of Figs. 1 to 6 may be combined among each other. In all embodiments or combinations of embodiments of Figs. 1 to 6 the electric shielding device 120, 204 may be electrically connected to the winding 103, 202, the distance D1, D2 between the winding 103, 202 and the electric shielding device 120, 204 may be between 5 to 40 mm, the first rounded edges 206 may have a radius of 5 to 20 mm, the second rounded edges 208 may have a radius of 2 to 5 mm, the electric shielding device 120, 204 may have an open ring shape or an annular shape, the electric shielding device 120, 204 may comprise a non-conductive material frame covered by a layer of conductive material, the cross-section of the shielding device 102, 204 may be selected from the group of polygonal cross-sections with rounded edges 206, 208, of semi-elliptical like cross-sections, or of a circular cross-section, and the cross-section of the attached insulation material may comprise rounded edges 401.

Fig. 7 schematically shows a flow chart of a method 700 of manufacturing a coil and electric shielding arrangement for a transformer. The method 700 comprises the steps of winding a winding of the transformer around a longitudinal axis A of the transformer forming the coil which may be a cylindrical-shaped coil 701, arranging an electric shielding device at a distance to the winding at an axial end of the winding perpendicular to the longitudinal axis and parallel to the top surface of the coil such that the electric shielding device covers the cross-section area of the winding perpendicular to the longitudinal axis 702, attaching an insulation material to the winding and to the electric shielding device providing the distance between the winding and the electric shielding device along the longitudinal axis 703.

While the invention has been illustrated and described in detail in the drawings and the foregoing description, such illustration and description are to be considered illustrative or exemplary and not restricted; the invention is not limited to the disclosed embodiments.

Other variants of the disclosed embodiments may be understood and affected by those skilled in the art and practising the claimed invention, from a study of the drawings, the disclosure, and the appended claims.

In the claims, the word "comprising" does not exclude other elements or steps, and the indefinite article "a" or "an" does not exclude a plurality. A single coil and electric shielding arrangement, or a single yoke and clamp and electric shielding device arrangement, or a single transformer, a single yoke or clamp, or a single electric shielding device may fulfil the function of several items recited in the claims. The mere fact that certain measures are recited in mutually different dependent claims does not indicate that a combination of these measures may not be used to advantage. Any reference signs in the claims should not be construed as limiting the scope.

LIST OF REFERENCE SYMBOLS

	100	Electric shielding element
	101	Transformer
	102	Clamp
5	103	Winding, high voltage winding
	104	Clamp edge(s)
	105	Rounded edges, first rounded edges
	106	Second rounded edges
	107	First end (of the electric shielding element)
10	108	Second end (of the electric shielding element)
	109	Yoke
	110	First region (at the yoke)
	111	Second region (that is not at the yoke)
	112	Second electric shielding device
15	113	limb(s)
	114	Ground connecting device
	120	Electric shielding device, first electric shielding device
	121	First limb end(s)
	122	Second limb end(s)
20	124	First yoke
	126	Second yoke
	130	First clamp(s)
	132	Second clamp(s)
	140	First electric shielding element(s)
25	142	Second electric shielding element(s)
	150	Longitudinal side (of the clamp)
	152	Transverse side (of the clamp)
	200	Coil and electric shielding arrangement, arrangement
	201	Insulation material, attached insulation material

- 202 Winding, low voltage winding
- 204 Electric shielding device, second electric shielding device
- 206 First rounded edge(s)
- 208 Second rounded edge(s)
- 5 301 Insulating barrier(s)
- 401 Rounded edges (of attached insulation material)

PATENT CLAIMS

1. A coil and electric shielding arrangement (200) for a dry-type transformer (101), the
5 electric shielding arrangement (200) comprising:
a winding (103, 202) wound around a longitudinal axis (A) of the transformer (101)
forming the coil;
an electric shielding device (120, 204) comprising a non-conductive material frame
covered by a layer of conductive material, which electric shielding device (120, 204) is
10 arranged at a distance (D1, D2) to the winding (103, 202) at an axial end (116, 118) of
the winding (103, 202) perpendicular to the longitudinal axis (A) and parallel to the top
surface of the coil such that the electric shielding device (120, 204) covers the cross-
section area of the winding (103, 202) perpendicular to the longitudinal axis (A),
an insulation material (201) attached to the winding (103, 202) and to the electric
15 shielding device (120, 204) providing the distance (D1, D2) between the winding (103,
202) and the electric shielding device (120, 204) along the longitudinal axis (A) such
that an environment of the winding (103, 202) is shielded against the electric field of
the winding (103, 202), wherein the winding (103, 202) and the electric shielding
device (120, 204) are casted in a block which insulates the electric shielding device
20 (120, 204) from the electric field of the winding (103, 202) by providing a distance
between the winding (103, 202) and the electric shielding device (120, 204).
2. The arrangement (200) of claim 1,
wherein the electric shielding device (120, 204) comprises:
25 first rounded edges (206) not facing the winding (103, 204); and
second rounded edges (208) facing the winding (103, 202);
wherein the radius of the first rounded edges (206) and the radius of the second
rounded edges (208) are adapted such that an electric shielding of the environment of
the winding (103, 202) is provided by the electric shielding device (120, 204).

3. The arrangement (200) of claim 2,
wherein the first rounded edges (206) have a radius of 5 to 20 mm, in particular 10 mm; and
wherein the second rounded edges (208) have a radius of 2 to 5 mm, in particular 3 mm.
- 5
4. The arrangement (200) of anyone of the preceding claims,
wherein the electric shielding device (120, 204) is electrically connected to the winding (103, 202).
- 10
5. The arrangement (200) of anyone of the preceding claims,
wherein the distance (D1, D2) between the winding (103, 202) and the electric shielding device (120, 204) is between 5 to 40 mm.
- 15
6. The arrangement (200) of anyone of the preceding claims,
wherein the electric shielding device (120, 204) has an open ring shape or an annular shape.
7. The arrangement (200) of anyone of the preceding claims,
wherein the casted block comprises rounded edges (401) near the electric shielding device (120, 204) with radii corresponding to the radii of the first rounded edges (206) of the electric shielding device (120, 204), in particular radii of 5 to 15 mm;
wherein the electric field generated by the windings is smoothed by a combination of the electric shielding device (120, 204) with the first rounded edges (206) and the rounded edges (401) of the cast block near the first rounded edges (206).
- 20
- 25
8. The arrangement (200) of anyone of the preceding claims,
wherein the cross-section of the shielding device (102, 204) is selected from the group of polygonal cross-sections with rounded edges (206, 208), of semi-elliptical like cross-sections, or of a circular cross-section.
- 30

9. The arrangement (200) of anyone of the preceding claims,
wherein the winding (103, 202) is a high voltage winding (103) and/or a low voltage winding (202);
wherein the electric shielding device (120, 204) covers the cross-section area of the
5 high voltage winding (103) and/or the low voltage winding (202) perpendicular to the longitudinal axis (A).
10. The arrangement (100) of anyone of the preceding claims,
wherein the cross-section of the attached insulation material (201) comprises rounded
10 edges (401).
11. The arrangement (200) of claim 8, further comprising:
a low voltage winding (202) with a second shielding device (204); and
an insulating barrier (301);
15 wherein the insulating barrier (301) is provided between the high voltage winding (103) and the low voltage winding (202) and is adapted to stop charge avalanche between the high voltage winding (103) and the low voltage winding (202).
12. A transformer (101) comprising:
20 an arrangement (200) of anyone of claims 1 to 11;
at least two limbs (113);
a yoke (109) connecting the at least two limbs (113); and
a clamp (102) attached at the yoke (109) and stabilizing the yoke (109);
wherein the winding (103, 202) is arranged around at least one of the at least two limbs
25 (113).
13. The transformer (101) of claim 12, further comprising:
a second electric shielding device (112) which is arranged at the yoke (109) between
the yoke (109) and a winding (103) of the transformer (101) and is adapted for
30 shielding the yoke (109) from an electric field of the winding (103); and

an electric shielding element (100) which is arranged at the clamp (102) between the clamp (102) and the winding (103) of the transformer (101) and which is adapted for shielding the clamp (102) from an electric field of the winding (103).

- 5 14. Method (700) of manufacturing a coil and electric shielding arrangement (200) for a transformer (101), the method (700) comprising the steps of:

Winding a winding (103, 202) of the transformer (101, 701) around a longitudinal axis (A) of the transformer (101) forming the coil (701);

10 Arranging an electric shielding device (120, 204) at a distance (D1, D2) to the winding (103, 202) at an axial end (116, 118) of the winding (103, 202) perpendicular to the longitudinal axis (A) and parallel to the top surface of the coil such that the electric shielding device (120, 204) covers the cross-section area of the winding (103, 202) perpendicular to the longitudinal axis (A, 702);

15 Attaching an insulation material (201) to the winding (103, 202) and to the electric shielding device (120, 204) providing the distance (D1, D2) between the winding (103, 202) and the electric shielding device (120, 204) along the longitudinal axis (A, 703).

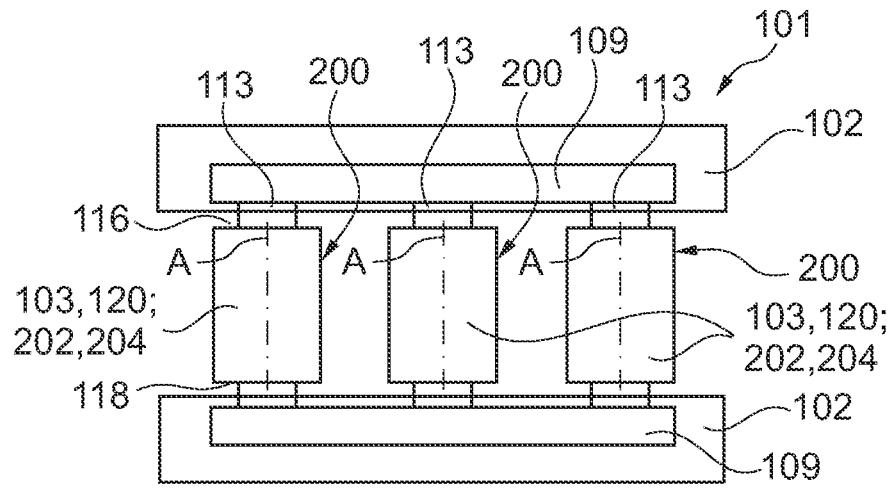

Fig. 1

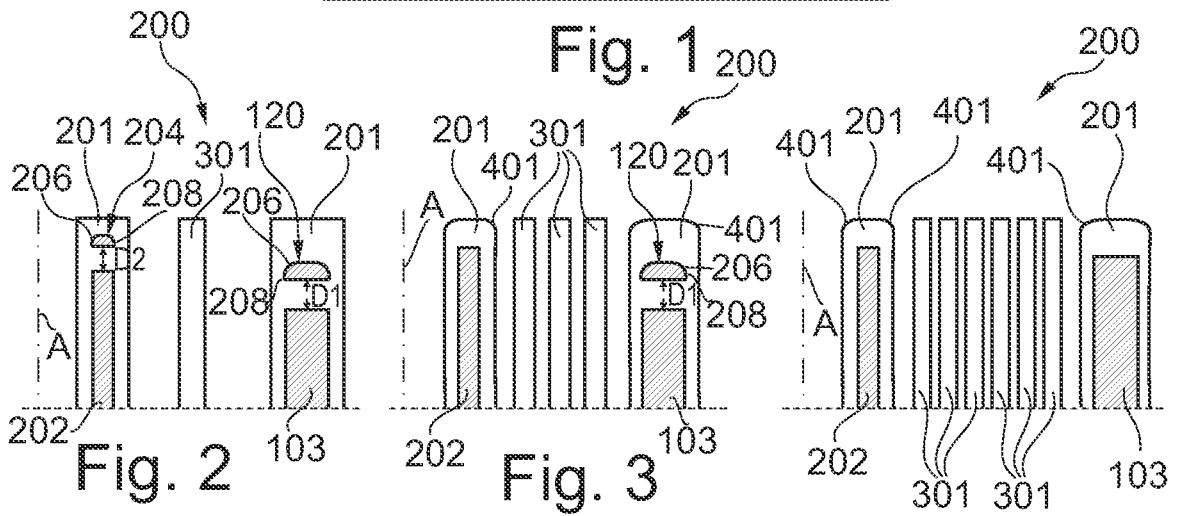

Fig. 2

Fig. 3

Fig. 4



Fig. 5

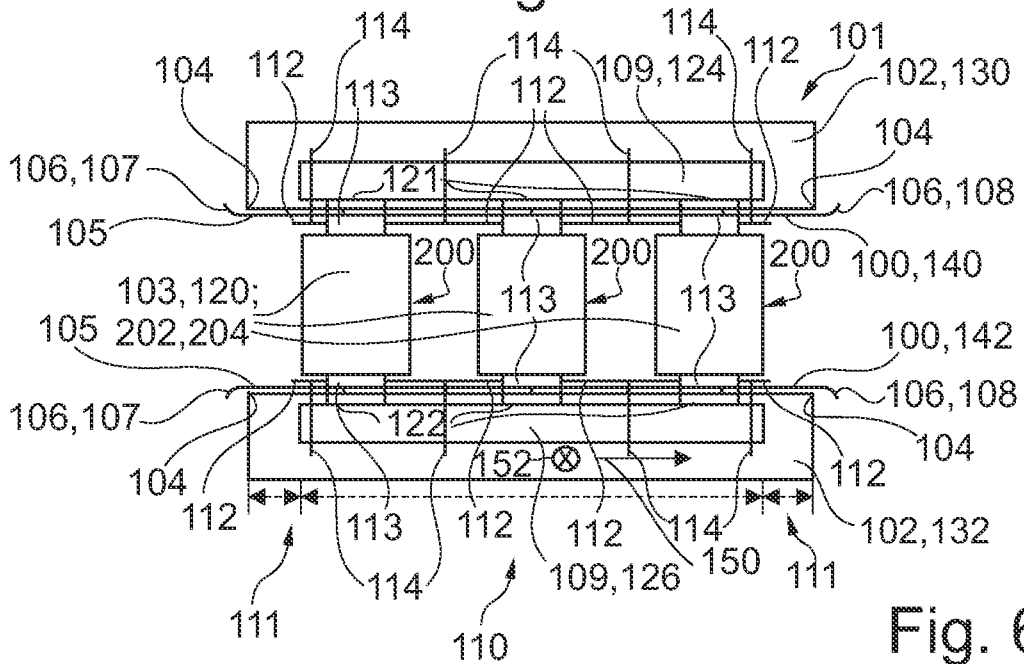

Fig. 6

2/2

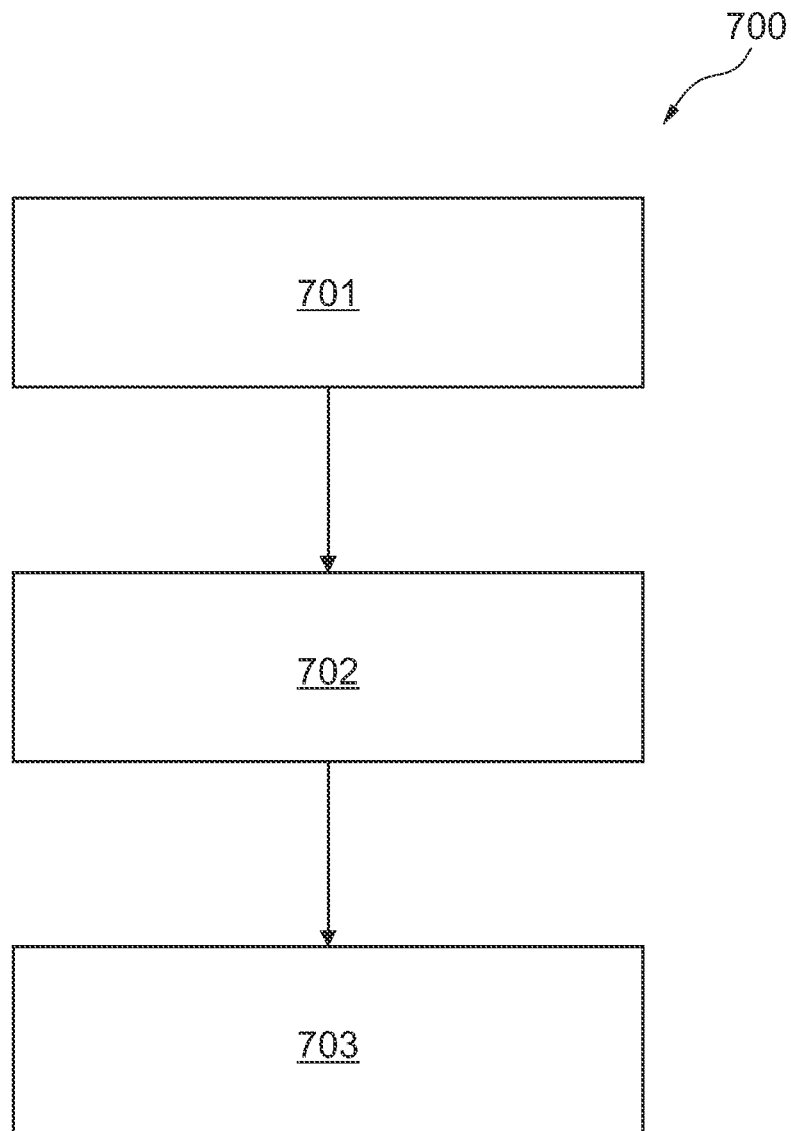

Fig. 7

INTERNATIONAL SEARCH REPORT

International application No

PCT/EP2011/060797

A. CLASSIFICATION OF SUBJECT MATTER
INV. H01F27/36
 ADD.
 According to International Patent Classification (IPC) or to both national classification and IPC

B. FIELDS SEARCHED
 Minimum documentation searched (classification system followed by classification symbols)
H01F H05K

Documentation searched other than minimum documentation to the extent that such documents are included in the fields searched

Electronic data base consulted during the international search (name of data base and, where practical, search terms used)
EPO-Internal

C. DOCUMENTS CONSIDERED TO BE RELEVANT

Category*	Citation of document, with indication, where appropriate, of the relevant passages	Relevant to claim No.
X	US 3 327 268 A (WILLY RABUS) 20 June 1967 (1967-06-20)	5,8
Y	column 1, lines 12, 13 column 5, lines 11-29, 53 - 72 column 6, lines 29-36	I-4,6,9 , II- 14
Y	----- wo 2008/026992 AI (ABB TECHNOLOGY LTD [CH]; FORSBERG ERIK [SE]; POLANDER TONY [SE]; SVENS) 6 March 2008 (2008-03-06) claim 1; figures 1,2 page 2, lines 11-27	1-4,6,9 , 11, 12
Y	----- DE 10 11 984 B (LICENTIA GMBH) 11 July 1957 (1957-07-11)	1,4,6,9 , 12, 13
A	column 1, lines 1-13 column 1, line 40 - column 2, line 21; figures 1,2	7
	----- -/-- -	

Further documents are listed in the continuation of Box C. See patent family annex.

* Special categories of cited documents :

"A" document defining the general state of the art which is not considered to be of particular relevance	"T" later document published after the international filing date or priority date and not in conflict with the application but cited to understand the principle or theory underlying the invention
"E" earlier document but published on or after the international filing date	"X" document of particular relevance; the claimed invention cannot be considered novel or cannot be considered to involve an inventive step when the document is taken alone
"L" document which may throw doubts on priority claim(s) or which is cited to establish the publication date of another citation or other special reason (as specified)	"Y" document of particular relevance; the claimed invention cannot be considered to involve an inventive step when the document is combined with one or more other such documents, such combination being obvious to a person skilled in the art.
"O" document referring to an oral disclosure, use, exhibition or other means	"&" document member of the same patent family
"P" document published prior to the international filing date but later than the priority date claimed	

Date of the actual completion of the international search 20 July 2011	Date of mailing of the international search report 28/07/2011
--	---

Name and mailing address of the ISA/ European Patent Office, P.B. 5818 Patentlaan 2 NL - 2280 HV Rijswijk Tel. (+31-70) 340-2040, Fax: (+31-70) 340-3016	Authorized officer Van den Berg, G
--	--

INTERNATIONAL SEARCH REPORT

 International application No
 PCT/EP2011/060797

C(Continuation). DOCUMENTS CONSIDERED TO BE RELEVANT		
Category*	Citation of document, with indication, where appropriate, of the relevant passages	Relevant to claim No.
Y	DE 474 029 C (EMI L HAEFELY & CIE AKT GES) 26 March 1929 (1929-03-26) page 2, lines 5-30; figure 1 -----	1, 12, 13
Y	US 5 990 775 A (INUI AKI FUMI [JP] ET AL) 23 November 1999 (1999-11-23)	1, 14
A	col umn 1, line 26 - line 27 col umn 2, line 52 - line 58 col umn 3, line 59 - col umn 4, line 24 col umn 6, line 15 - line 62; figure 6 -----	2,4,6-12
A	DE 25 05 085 AI (SCHORCH GMBH) 19 August 1976 (1976-08-19) page 1, lines 1-19 -----	1-6,12, 14
Y	US 2 937 349 A (GUGLI ELMO CAMI LLI) 17 May 1960 (1960-05-17) col umn 3, line 24 - line 29 col umn 4, line 27 - line 37; figures 1, 2 -----	12, 13

INTERNATIONAL SEARCH REPORT

Information on patent family members

International application No PCT/EP2011/060797
--

Patent document cited in search report	Publication date	Patent family member(s)	Publication date
US 3327268	A	20-06-1967	AT 243914 B 10-12-1965
			CH 430870 A 28-02-1967
			DE 1256313 B 14-12-1967
			GB 1058102 A 08-02-1967
			NL 6407249 A 28-12-1964

W0 2008026992	A1	06-03-2008	CN 101136281 A 05-03-2008
			CN 201134338 Y 15-10-2008
			EP 2064715 A1 03-06-2009
			RU 2009109840 A 10-10-2010
			US 2010007452 A1 14-01-2010
			ZA 200901090 A 30-12-2009

DE 1011984	B	11-07-1957	NONE

DE 474029	C	26-03-1929	NONE

US 5990775	A	23-11-1999	NONE

DE 2505085	A1	19-08-1976	NONE

US 2937349	A	17-05-1960	NONE
