



- (51) **International Patent Classification:**
F21S 8/04 (2006.01)
- (21) **International Application Number:**
PCT/US20 13/020073
- (22) **International Filing Date:**
3 January 2013 (03.01.2013)
- (25) **Filing Language:** English
- (26) **Publication Language:** English
- (30) **Priority Data:**
13/345,215 6 January 2012 (06.01.2012) US
13/633,207 2 October 2012 (02.10.2012) US
- (71) **Applicant: CREE, INC.** [US/US]; 4600 Silicon Drive, Durham, North Carolina 27703 (US).
- (72) **Inventors: LAY, James Michael;** 3205 Summer Oaks Drive, Apex, North Carolina 27539 (US). **PICKARD, Paul Kenneth;** 1325 Legendary Lane, Morrisville, North Carolina 27560 (US). **DURKEE, John;** 1107 Mordecai Drive, Apartment 100, Raleigh, North Carolina 27604 (US). **LU, Dong;** 706 Weavers Ridge Drive, Cary, North Carolina 27519 (US). **NGUYEN, Nick Hoang;** 4132 Hope Valley Road, Durham, North Carolina 27707 (US).
- (74) **Agent: PHILLIPS, Steven B.;** Moore & Van Allen, PLLC, Po Box 13706, Research Triangle Park, North Carolina 27709 (US).
- (81) **Designated States** (unless otherwise indicated, for every kind of national protection available): AE, AG, AL, AM,

AO, AT, AU, AZ, BA, BB, BG, BH, BN, BR, BW, BY, BZ, CA, CH, CL, CN, CO, CR, CU, CZ, DE, DK, DM, DO, DZ, EC, EE, EG, ES, FI, GB, GD, GE, GH, GM, GT, HN, HR, HU, ID, IL, IN, IS, JP, KE, KG, KM, KN, KP, KR, KZ, LA, LC, LK, LR, LS, LT, LU, LY, MA, MD, ME, MG, MK, MN, MW, MX, MY, MZ, NA, NG, NI, NO, NZ, OM, PA, PE, PG, PH, PL, PT, QA, RO, RS, RU, RW, SC, SD, SE, SG, SK, SL, SM, ST, SV, SY, TH, TJ, TM, TN, TR, TT, TZ, UA, UG, US, UZ, VC, VN, ZA, ZM, ZW.

- (84) **Designated States** (unless otherwise indicated, for every kind of regional protection available): ARIPO (BW, GH, GM, KE, LR, LS, MW, MZ, NA, RW, SD, SL, SZ, TZ, UG, ZM, ZW), Eurasian (AM, AZ, BY, KG, KZ, RU, TJ, TM), European (AL, AT, BE, BG, CH, CY, CZ, DE, DK, EE, ES, FI, FR, GB, GR, HR, HU, IE, IS, IT, LT, LU, LV, MC, MK, MT, NL, NO, PL, PT, RO, RS, SE, SI, SK, SM, TR), OAPI (BF, BJ, CF, CG, CI, CM, GA, GN, GQ, GW, ML, MR, NE, SN, TD, TG).

Declarations under Rule 4.17:

- as to applicant's entitlement to apply for and be granted a patent (Rule 4.17(H))
- as to the applicant's entitlement to claim the priority of the earlier application (Rule 4.17(in))

Published:

- without international search report and to be republished upon receipt of that report (Rule 48.2(g))

(54) **Title:** LIGHT FIXTURE WITH TEXTURED REFLECTOR

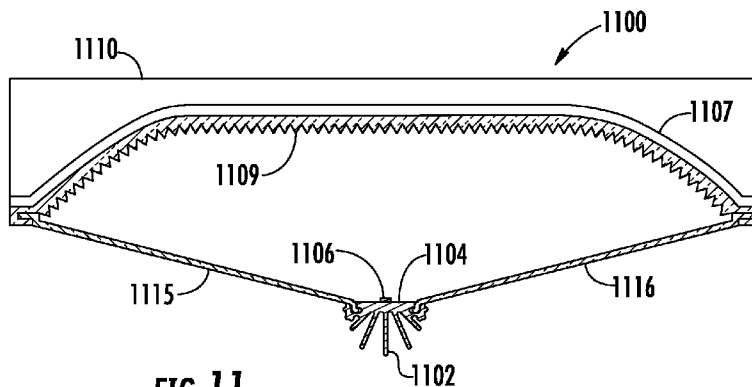

FIG. 11

(57) **Abstract:** A light fixture with a textured reflector surface is disclosed. Embodiments of the present invention provide for a lighting system in which LEDs face, and the majority of light from the LED light source is incident on, a textured surface of a back reflector (108, 408, 508, 808, 1008, 1208) while producing minimal glare and minimal imaging of the light source. Such a reflector (108, 408, 508, 808, 1008, 1208) may be referred to as a retro-reflector. The reflector (108, 408, 508, 808, 1008, 1208) for the light fixture (100, 800, 1000, 1100, 1300) can be made from a relatively inexpensive material such as polycarbonate, which without texturing has a specular or semi-specular surface. This material (410, 510, 1109, 1309) can be used alone or with a metal substrate (1107, 1307) to form the reflector (108, 408, 508, 808, 1008, 1208). The textured surface can be textured by way of an imprinted pattern or by roughening, and can be extruded. A prismatic texture may be used. The texturing can also be spatially varied.



LIGHT FIXTURE WITH TEXTURED REFLECTOR

DESCRIPTION

This application claims priority from patent application serial number U.S.
5 13/345,215, filed 06 January 2012, and patent application serial number U.S.
13/633,207, filed 02 October 2012, the entire disclosures of which are hereby
incorporated herein by reference.

Background Art

Light emitting diode (LED) lighting systems are becoming more prevalent as
10 replacements for existing lighting systems. LEDs are an example of solid state lighting
(SSL) and have advantages over traditional lighting solutions such as incandescent and
fluorescent lighting because they use less energy, are more durable, operate longer, can
be combined in multi-color arrays that can be controlled to deliver virtually any color
light, and generally contain no lead or mercury. In many applications, one or more LED
15 dies (or chips) are mounted within an LED package or on an LED module, which may
make up part of a lighting unit, lamp, "light fixture" or more simply a "fixture," which
includes one or more power supplies to power the LEDs. An LED fixture may be made
with a form factor that allows it to replace a standard fixture or bulb. LEDs can also be
used in place of florescent lights as backlights for displays.

20 For most LED lamps and fixtures, LEDs may be selected to provide various light
colors to combine to produce light output with a high color rendering index (CRI). The
desired color mixing may be achieved, for example, using blue, green, amber, red and/or
red-orange LED chips. One or more of the chips may be in a package with a phosphor or
may otherwise have a locally applied phosphor. For example a red LED may be

combined with a blue LED and a yellow phosphor to provide a blue-shifted-yellow plus red color system. Translucent or transparent materials may be used with LED lighting fixtures to provide diffusion, color mixing, to otherwise direct the light, or to serve as an enclosure to protect the LEDs.

5 Rigid or semi-rigid materials may be included in a fixture or lamp as optical elements external to the LED modules themselves. Such optical elements may allow for localized mixing of colors, collimate light, and provide the minimum beam angle possible. Such optical elements may include reflectors, lenses, and/or lens plates. Reflectors can be, for example, of the metallic, mirrored type, in which light reflects
10 from opaque silvered surfaces, or be made of or use white or near-white highly reflective material, or diffusive material. Reflectors can also made of or include a substrate made of plastic or metal coated with another material. Lenses can vary in complexity and level of optical effect, and can be or include traditional lenses, total internal reflection optics, or glass or plastic plates with or without coatings or additives.

15 Disclosure of Invention

Embodiments of the present invention provide for a lighting system in which LEDs face, and the majority of light is incident on, a textured back reflector while producing minimal glare. Further, the reflector for the light fixture can be made or partially made from a material such as polycarbonate, which has a specular or semi-
20 specular surface when the surface is smooth. The material can stand-alone or be fixed to a metal substrate to produce a plenum-rated fixture. Embodiments of the invention provide for a reflector that minimizes glare and imaging of the LED light source without the use of a costly diffuse white layer.

In example embodiments, a light fixture includes an LED light source to emit light, and a reflector with a textured surface to reflect the light. The reflector is configured to receive light from the LED light source in some embodiments so that at least 70 % of the light is incident on the textured surface of the reflector. In some 5 embodiments, at least 80 % of the light is incident on the textured surface. In some embodiments, at least 90 % or at least 95 % of the light is incident on the textured surface. Such a system might be called a "retro-reflective" system or be described as "retro-reflecting" because very little to no light is directed straight from the light source into the illumination area. In some embodiments, the textured reflector is textured by 10 way of an imprinted pattern. In some embodiments the reflector is extruded and the pattern can be imprinted as part of the extrusion process, either during or just after the reflector is shaped.

The reflector may be made of polycarbonate, or any other suitable material that would be at least semi-specular without texturing or with no texture present. In some 15 embodiments, the imprinted pattern used to texture the reflector is a prismatic pattern. A textured reflector used in a retro-reflective application that uses a prismatic texturing pattern may be referred to as a prismatic retro-reflector. The pattern may vary spatially relative to the LED light source and/or the center of the reflector. In some embodiments, a light fixture using the textured reflector may be coextruded with a lens plate or lens 20 plates. In some embodiments, the reflector includes a metal substrate and the textured material is fixed to the metal substrate.

In some embodiments, the texturing can be imparted to the reflector by roughening the interior surface of the reflector. As in the case of imprinting, polycarbonate can be used, as can polycarbonate fixed to a metal substrate. Also as in

the case of imprinting, the intensity of the roughening can vary spatially relative to the center of the reflector and/or the positioning of the LED light source. The roughening can be accomplished in a number of different ways, regardless of whether the reflector is initially made by extrusion or by some other method.

5 The reflector that is described herein can provide color mixing and reduce color hot spots and reflections in a light fixture that uses multiple color LEDs with or without lumiphors such as phosphors as a light source. As an example some fixtures include blue-shifted yellow plus red (BSY+R) LED systems, wherein the LED light source includes at least two groups of LEDs, wherein one group emits light having a dominant
10 wavelength from 435 to 490 nm, and another group emits light having a dominant wavelength from 600 to 640 nm. In such a case, one group can be packaged with a phosphor, which, when excited, emits light having a dominant wavelength from 540 to 585 nm. In some embodiments, the first group emits light having a dominant wavelength from 440 to 480 nm, the second group emits light having a dominant
15 wavelength from 605 to 630 nm, and the lumiphor emits light having a dominant wavelength from 560 to 580 nm.

 A lighting system according to some example embodiments of the invention is operated by energizing an LED light source and directing at least 70 % of light from the LED light source to be incident on the side of the reflector with the textured surface. In
20 some embodiments, at least 80 % of the light is incident on the textured surface, and in some embodiments at least 90 % or at least 95 % of the light is incident on the textured surface. At least a portion of the light incident on the reflector is directed into the illumination area. Although a large portion of the light from the LED light source is incident on the reflector, the amount reflected will vary based on the fixture design, as

some fixtures may have at least one opening to create "up-light" necessarily reducing the amount reflected into the illumination area. A fixture may also have a transparent or translucent section co-molded, co-extruded, or otherwise included to allow for transmission of "up-light."

5

Brief Description of the Drawings

FIG. 1 is a top perspective view of a linear lighting system or linear light fixture according to at least some embodiments of the present invention.

FIG. 2 is a cross-sectional view of the lighting system of FIG. 1.

FIG. 3 is a cross-sectional view of the heatsink and light source for the light
10 fixture of FIG. 1.

FIG. 4 is an enlarged cross-sectional view of a portion of the reflector for the lighting system of FIG. 1.

FIG. 5 is an enlarged cross-sectional view of a portion of a reflector for a light fixture according to additional embodiments of the present invention.

15 FIGs. 6A and 6B show enlarged perspective views of a portion of the reflector for the lighting system of FIG. 1. FIG. 6A is a broader view and FIG. 6B shows one prismatic element of the reflector.

FIGs. 7A and 7B show enlarged perspective views of a portion of a reflector for a light fixture according to additional embodiments of the invention. FIG. 7A is a broader
20 view and FIG. 7B shows one prismatic element of the reflector.

FIG. 8 is a cross-section view of a fixture according to example embodiments of the invention that is similar to that shown in FIGs. 1, 2 and 3, except that the reflector has a spatially varying texture. The fixture is also longer.

FIGs. 9A and 9B are a cross-sectional side view and a bottom view, respectively,
5 of the light fixture of FIG. 8.

FIGs. 10A and 10B are a cross-sectional side view and a bottom view, respectively, of another light fixture according to example embodiments of the present invention. This fixture is similar to the one shown in FIGs. 1, 2 and 3, but includes a pan.

10 FIG. 11 is a cross-sectional view of a lighting system according to additional embodiments of the present invention.

FIG. 12 is an enlarged cross-sectional view of a portion of the reflector for the lighting system of FIG. 11.

FIGs. 13A and 13B are a cross-sectional side view and a bottom view,
15 respectively, of a light fixture according to additional example embodiments of the invention. This fixture is square and includes a pan.

Best Mode(s) for Carrying Out the Invention

Embodiments of the present invention now will be described more fully hereinafter with reference to the accompanying drawings, in which embodiments of the
20 invention are shown. This invention may, however, be embodied in many different forms and should not be construed as limited to the embodiments set forth herein.

Rather, these embodiments are provided so that this disclosure will be thorough and complete, and will fully convey the scope of the invention to those skilled in the art. Like numbers refer to like elements throughout.

It will be understood that, although the terms first, second, etc. may be used
5 herein to describe various elements, these elements should not be limited by these terms. These terms are only used to distinguish one element from another. For example, a first element could be termed a second element, and, similarly, a second element could be termed a first element, without departing from the scope of the present invention. As used herein, the term "and/or" includes any and all combinations of one or more of the
10 associated listed items. Also, when a process or method is described, the steps or sub-processes recited may be performed in any order or simultaneously, unless otherwise stated.

It will be understood that when an element such as a layer, region or substrate is referred to as being "on" or extending "onto" another element, it can be directly on or
15 extend directly onto the other element or intervening elements may also be present. In contrast, when an element is referred to as being "directly on" or extending "directly onto" another element, there are no intervening elements present. It will also be understood that when an element is referred to as being "connected" or "coupled" to another element, it can be directly connected or coupled to the other element or
20 intervening elements may be present. In contrast, when an element is referred to as being "directly connected" or "directly coupled" to another element, there are no intervening elements present.

Relative terms such as "below" or "above" or "upper" or "lower" or "horizontal" or "vertical" may be used herein to describe a relationship of one element, layer or region to another element, layer or region as illustrated in the figures. It will be understood that these terms are intended to encompass different orientations of the device in addition to
5 the orientation depicted in the figures.

The terminology used herein is for the purpose of describing particular embodiments only and is not intended to be limiting of the invention. As used herein, the singular forms "a", "an" and "the" are intended to include the plural forms as well, unless the context clearly indicates otherwise. It will be further understood that the terms
10 "comprises" "comprising," "includes" and/or "including" when used herein, specify the presence of stated features, integers, steps, operations, elements, and/or components, but do not preclude the presence or addition of one or more other features, integers, steps, operations, elements, components, and/or groups thereof.

Unless otherwise defined, all terms (including technical and scientific terms) used
15 herein have the same meaning as commonly understood by one of ordinary skill in the art to which this invention belongs. It will be further understood that terms used herein should be interpreted as having a meaning that is consistent with their meaning in the context of this specification and the relevant art and will not be interpreted in an idealized or overly formal sense unless expressly so defined herein.

20 Unless otherwise expressly stated, comparative, quantitative terms such as "less" and "greater", are intended to encompass the concept of equality. As an example, "less" can mean not only "less" in the strictest mathematical sense, but also, "less than or equal to."

Reflections, glare and color hot spots are all possible concerns with LED lamps and fixtures. For example, strong glare and color hot spots sometimes occur because LEDs are closer to a point source of light than the source in other types of lighting products and multiple color devices are often used together to create substantially white light. Indirect LED lighting systems typically have their LEDs facing a back reflector, and the majority of the light from the LEDs is reflected from the back reflector before the light shines into the application area. This structure alleviates glare and provides color mixing when the back reflector is highly diffusive. However, highly reflective materials used for the back reflector can increase optical efficiency and reduce costs. Some highly reflective materials are also specular or semi-specular. A specular or semi-specular back reflector can image of LED light sources causing glare and/or color hot spots. In example embodiments of the invention, a back reflector includes a material that is highly reflective and at least semi-specular, but the material is textured to reduce glare and imaging. The example fixtures described herein are LED lighting systems and the LEDs together can be referred to as an LED light source. However, lighting systems can take many forms and a lighting system according to an embodiment of the invention might be referred to by other terms such as a lamp, luminaire or a light panel, for example.

Embodiments of the invention can use a white, specular or semi-specular material such as polycarbonate (PC). Such a material can be extruded to produce the reflector, and the extruded part can provide both mechanical support and back reflection. The reflector can optionally include a substrate to support the material. The substrate can be made of metal. Examples of a PC material that can be used for the reflective surface are FR6901, FR3030 from Bayer AG and BFL2000U from Sabic Innovative Plastics Holdings. In example embodiments of the invention, the material is textured in any of

various ways. The material can be described as "at least semi-specular" when no texturing is present. A material is termed specular when a smooth surface of a structure made from the material is mirror-like, causing parallel light rays that are incident on the surface to reflect in parallel, with the result that humans perceive a reflected image in the surface of the material. A material is termed semi-specular when such light rays are only partially parallel, with the result that humans perceive a distorted image in the surface. If a material is at least semi-specular, humans can perceive anything in the surface from a much distorted, barely perceptible image to a perfect reflection, depending on the specifics of the material and the structure.

Note that specularity is not the same as reflectivity, which refers only to the total amount of light reflected from a surface, regardless of the cohesiveness of the reflected rays of light. However, the reflectivity of a reflector material can be significant in terms of the efficiency of a lighting system. The material used for reflective surfaces of reflectors for fixtures according to example embodiments of the invention can have a reflectivity of at least 90 %, or least 95 %, or in some cases, at least 97 %.

As just one example of a textured reflector according to embodiments of the invention, thin extruded high reflectivity PC plates can have a pattern imprinted as part of the extrusion process, and the plates can be pressed onto an un-textured extruded PC back reflector substrate. Alternatively, the entire reflector can be extruded with an imprinted pattern on the inside or bottom surface of the reflector. Either type of imprinting can be accomplished with a textured drum as part of the extrusion process. A roughening pattern can also be applied by roughening a reflector or a plate to be pressed on to a reflector substrate with sand blasting, sanding, or another roughening technology.

FIG. 1 is a top perspective view of a light fixture 100, and FIG. 2 is a cross-sectional view of light fixture 100 according to example embodiments of the invention. Light fixture 100 is a linear fixture, which can be, as an example, a suspended linear light fixture. Light fixture 100 includes heatsink 102 having a mounting surface 104 on which
5 LED packages or devices 106 can be mounted or fixed to collectively serve as a light source. Light fixture 100 also includes reflector 108 and end caps 110 and 111. End cap 110 is larger than end cap 111 and is shaped to act as a circuit box to house electronics used to drive and control the light source such as rectifiers, regulators, timing circuitry, and other components. The fixture illustrated in FIGs 1 and 2 is designed to be
10 suspended from a ceiling with chains or stanchions (not shown) but a similar troffer style fixture can also be designed to be installed in ceiling with appropriate materials.

In the example of FIGs. 1 and 2, reflector 108 includes a relatively flat region opposite the mounting surface of the heatsink; however, a reflector for a light fixture according to embodiments of the invention can take various shapes. For example,
15 reflector 108 could be parabolic in shape, or include two or more parabolic regions. Light fixture 100 also includes two optional lens plates, 115 and 116, disposed at the sides of the heatsink. In the perspective view of FIG. 1 the outline of these lens plates is shown in dotted lines since the plates are not normally visible from this angle. In this particular embodiment, the lens plates and the reflector have been coextruded, resulting
20 in a strong mechanical and/or chemical interlock at points 120 and 122. However, if such lens plates are used, they can be attached in other ways, including by being retained in channels formed with or in the reflector. Also visible in FIG. 2 is texturing 130 on the inside surface of reflector 108 facing LED devices 106. This texturing will be shown and describe in more detail later with respect to FIG. 4 through FIG. 7B. It should be

noted that in FIG. 2 as well as in some of the other figures, the size and/or thickness of the texturing is not to scale and is exaggerated for clarity. Structures in any of the drawings may be sized to show detail without regard to the scale of a structure relative to other parts of a drawings or to parts shown in other drawings. Also, shapes may be
5 exaggerated or simplified as appropriate for illustrative purposes. The drawings herein are for the most part intended to be schematic in nature and not necessarily literal representations.

FIG. 3 is a close-up, cross-sectional view of the heatsink area of example light fixture 100 of FIG. 2, in which heatsink 102 and the light source are visible in some
10 detail. It should be understood that FIG. 3 provides an example only as many different heatsink structures could be used with an embodiment of the present invention. The orientation of the heatsink relative to a room being illuminated is indicated. The topside portion of heatsink 102 faces the interior cavity of the light engine. Heatsink 102 includes fin structures 304 and mounting surface 104. The mounting surface 104
15 provides a substantially flat area on which LED devices 106 can be mounted for use as a light source. These LEDs can be mounted directly on the heatsink, depending on the material and provisions for wiring the LEDs. Alternatively, a metal core printed circuit board (PCB) can be mounted on the heatsink and the LEDs mounted on the PCB.

The LED devices 106 of FIGs. 2 and 3 can be mounted to face orthogonally to
20 the mounting surface 104 to face the center region of the reflector, or they may be angled or tilted to face other portions of the reflector. In some embodiments, an optional baffle 310 (shown in dotted lines) may be included. The baffle 310 reduces the amount of light emitted from the LED light source at high angles that may escape the cavity of the light

fixture without being reflected. Such baffling can help prevent hot spots or color spots visible when viewing the fixture at high viewing angles.

FIG. 4 is an enlarged cross-sectional view of a reflector 408 that can be used in a light fixture like the one illustrated in FIGs. 1 and 2. In this example, the polycarbonate material 410 is textured with an imprinted pattern 412. In this particular example the pattern is a prismatic pattern that will be further discussed below with respect to FIGs. 6A and 6B. Any other pattern could be used and prismatic patterns can vary greatly. Another example imprinted pattern is a cut keystone pattern.

FIG. 5 is an enlarged cross-sectional view of a reflector 508 that can be used in a light fixture that the one illustrated in FIGs. 1 and 2. In this example, the polycarbonate material 510 is textured with a roughening pattern on surface 512. In this particular example, the pattern has been applied by sandblasting, but any number of other methods of creating a roughening pattern on the inside or downward facing surface of reflector 508 can be used. The amount of time spent roughening surface 512 as well as the size of character of any media used for roughening can be chosen to vary the amount, positioning and coarseness of the roughening pattern on the reflector.

FIGs. 6A and 6B illustrate a type of prismatic pattern that can be applied to a reflector according to some embodiments of the invention. Section 600 of a reflector is shown in FIG. 6A and a single prismatic element 602 of the reflector is shown in FIG. 6B. This type of pattern, which includes repeated prismatic elements extending in all directions, is sometimes used in clear lens material. The "prism" has a curved edge 604 and the size of the prism in the pattern that is often specified by an "R" value, such as R9 or R20. In the example of FIGs 6A and 6B, the "prism" extends into the reflector. Such

a pattern may be referred to as a "female prismatic pattern." The prismatic elements could also be described as pyramidal in shape. In the case of FIGs. 6A and 6B, the "pyramids" have a rounded tip and soft, rounded edges.

FIGs. 7A and 7B illustrate another type of prismatic pattern that can be applied to a reflector according to some embodiments of the invention. Section 700 of a reflector is shown in FIG. 7A and a single prismatic element 702 of the reflector is shown in FIG. 6B. This type of pattern, which includes repeated prismatic elements extending in all directions, is sometimes used in clear lens material. The prism again has a curved edge 704 that is often specified with an R-value. In the example of FIGs 7A and 7B, the "prism" protrudes from the reflector. Such a pattern may be referred to as a "male prismatic pattern." The prismatic elements could also be described as pyramidal in shape. In the case of FIGs. 7A and 7B, the "pyramids" have a sharp tip and well-defined edges. It should be noted that these shapes are examples only, and an appropriate texture pattern might have any manner of edges, curves and the like. It should also be noted that a reflector for a retro-reflective system using a prismatic pattern may be referred to herein as a prismatic retro-reflector.

The example reflectors for light fixtures as described herein are configured relative to the LED light source so that at least 70 % of the light from the source is incident on the reflector. In some embodiments, more light might be incident on the reflector, for example, at least 80 %, at least 90 % or at least 95 %. The amount of this light actually reflected into the illumination area of the room where a fixture is used varies by system design. If the entire reflector surface is used to reflect the light, a very large portion of the light enters the room. However, embodiments of the invention can be used with reflectors that include diffusive lenses or lens plates, windows, or clear

areas in the reflector itself to allow for up-lighting. In such a case only the actual reflective portions of the reflector need be textured according to example embodiments of the invention.

FIG. 8 is a cross-sectional view of light fixture 800 according to further example
5 embodiments of the invention. Light fixture 800 is a linear fixture, which can be, as an example, a suspended linear light fixture, and is similar in most respects to the light fixture illustrated in FIGs. 1 and 2. Light fixture 800 includes heatsink 802 having a mounting surface 804 on which LED packages or devices 806 can be mounted or fixed to collectively serve as a light source. Light fixture 800 also includes reflector 808 and
10 an end cap 810 is visible. The fixture illustrated in FIG 8 is designed to be suspended from a ceiling with chains or stanchions (not shown) but a similar troffer style fixture can also be designed to be installed in ceiling with appropriate materials.

In the example of FIG. 8, reflector 808 again includes a relatively flat region opposite the mounting surface of the heatsink and includes spatially varying texturing;
15 wherein the depth and/or frequency of an imprinted pattern 830 is/are increased in the flat region. Such texturing can be either imprinted, formed by roughening or created in some other way, but can still vary spatially, and may be said to spatially vary relative to the center of the reflector or the position of the LED light source. It is again noted that a reflector according to embodiments of the invention can take various shapes. Light
20 fixture 800 also includes two optional lens plates, 815 and 816, disposed at the sides of the heatsink. Again in this embodiment, the lens plates and the reflector have been coextruded, resulting in a strong mechanical and/or chemical interlock at points 820 and 822. However, if such lens plates are used, they can also be retained in channels formed with the reflector or attached in some other way.

FIG. 9A is a cutaway side view of a linear light fixture 800 of FIG. 8, and FIG. 9B is a bottom view of light fixture 800. Again, fixture 800 is similar to the fixture shown in FIGs. 1 and 2. However, in the views of FIGs. 9A and 9B it can be seen to be longer. End caps 810 and 905 provide support for the fixture. End cap 810 is larger than end cap 905 and is shaped to act as a circuit box to house electronics used to drive and control the light sources such as rectifiers, regulators, timing circuitry, and other components. Wiring from the end cap/circuit box to the light sources can be passed through holes or slots in heatsink 802, or the LEDs can receive power through a metal core PCB mounted on the surface of the heatsink. If a PCB is used, a wiring harness from the end cap/circuit box can be connected to the PCB. Reflector 808 is visible in FIG. 9A, but is occluded from view by the lens plates 815 and 816, and heatsink 802. The bottom side of heatsink 802 exposed to the room environment. Also visible in FIG. 9A is the spatially varying textured inner surface 830 of reflector 808 according to example embodiments of the invention.

FIG. 10A is a cutaway side view of a light fixture 1000, and FIG. 10B is a bottom view of light fixture 1000. Circuit box 1004 is attached to the backside of the light fixture. Circuit box 1004 again houses electronics used to drive and control the light sources such as rectifiers, regulators, timing circuitry, and other components. Circuit box 1004 is attached to one end of reflector 1008. Wiring from the circuit box to the light sources can be passed through holes or slots in heat sink 1012, or the LEDs can receive power through a metal core PCB mounted on the surface of the heatsink. If a PCB is used, a wiring harness from the end cap/circuit box can be connected to the PCB. In FIG. 10B, the reflector 1008 is occluded from view by the lens plates 1015 and 1016 and the heatsink 1012. The bottom side of the heatsink 1012 is exposed to the room

environment. Pan 1020 is sized to fit around the light engine and enable the fixture to be installed in a ceiling as a troffer, or simply to have a larger profile. Also visible in FIG. 10A is the inner surface 1040 of reflector 1008, which is textured according to example embodiments of the invention.

5 FIG. 11 is a cross-sectional view of light fixture 1100 according to example embodiments of the invention. Light fixture 1100 has a similar design to that shown in FIGs. 1 and 2 in terms of being a linear fixture, which can be, as an example, a suspended linear light fixture. Light fixture 1100 includes heatsink 1102 having a mounting surface 1104 on which LED packages or devices 1106 can be mounted or
10 fixed to collectively serve as a light source. Light fixture 1100 also includes a reflector and end caps, one of which 1110 is visible in the diagram. End cap 1110 again acts as a circuit box to house electronics used to drive and control the light source such as rectifiers, regulators, timing circuitry, and other components. The fixture illustrated in FIG 11 is designed to be suspended from a ceiling with chains or stanchions (not shown)
15 but a similar troffer style fixture can also be designed to be installed in ceiling with appropriate materials, and will be discussed with respect to FIGs. 13A and 13B.

The reflector in the example of FIG. 11 includes a metal substrate 1107 and a layer of material 1109 with a textured surface as previously described. The reflector again includes a relatively flat region opposite the mounting surface of the heatsink;
20 however again, a reflector for a light fixture according to embodiments of the invention can take various shapes. Light fixture 1100 also includes two optional lens plates, 1115 and 1116, disposed at the sides of the heatsink. As before, if such lens plates are used, they can be attached in other ways, including by being retained in channels formed with or in the reflector.

FIG. 12 illustrates a section of a reflector 1208 that could be used in the fixture of FIG. 11, in a troffer style light fixture, or in many different applications and may take any of various sizes and shapes. Substrate 1107 is metal in this example embodiment, and therefore could be used in a plenum application, but substrate 1107 could also be
5 plenum rated plastic or another material suited for the particular application as appropriate. Material 1109 is a white reflective, specular or semi-specular material such as polycarbonate (PC). Such a material can be extruded with the metal or other material to produce the reflector, and the extruded part can provide both mechanical support and back reflection. As previously described, the texture can be applied to the inner surface
10 during extrusion or other techniques.

FIG. 13A is a cutaway side view of a light fixture 1300, and FIG. 13B is a bottom view of light fixture 1300. This troffer fixture is similar to that previously described with respect to FIGs. 10A and 10B, except that it is square in shape and includes a reflector with a metal substrate. Circuit box 1304 is attached to the backside of the light
15 fixture. Circuit box 1304 again houses electronics used to drive and control the light sources such as rectifiers, regulators, timing circuitry, and other components. Circuit box 1304 is attached to one end of a reflector including a metal substrate 1307 and material 1309, which is again a white reflective, specular or semi-specular material such as polycarbonate (PC). The material has a textured inner surface as previously
20 discussed. Wiring from the circuit box to the light sources can be passed through holes or slots in heat sink 1312, or the LEDs can receive power through a metal core PCB mounted on the surface of the heatsink. If a PCB is used, a wiring harness from the end cap/circuit box can be connected to the PCB. In FIG. 13B, the reflector is occluded from view by the lens plates 1315 and 1316 and the heatsink 1312. The bottom side of the

heatsink 1312 is exposed to the room environment. Pan 1320 is sized to fit around the light engine and enable the fixture to be installed in a ceiling as a troffer. Also visible in FIG. 13A is the inner textured surface of material 1309, which is can be textured with a pattern as discussed herein.

5 A multi-chip LED package used with an embodiment of the invention and can include light emitting diode chips that emit hues of light that, when mixed, are perceived in combination as white light. Phosphors can also be used. Blue or violet LEDs can be used in the LED devices and the appropriate phosphor can be deployed elsewhere within the fixture. LED devices can be used with phosphorized coatings packaged locally with
10 the LEDs to create various colors of light. For example, blue-shifted yellow (BSY) LED devices can be used with a red phosphor on or in a carrier or on the reflector to create substantially white light, or combined with red emitting LED devices on the heatsink to create substantially white light. Such embodiments can produce light with a CRI of at least 70, at least 80, at least 90, or at least 95. By use of the term substantially white
15 light, one could be referring to a chromacity diagram including a blackbody locus of points, where the point for the source falls within four, six or ten MacAdam ellipses of any point in the blackbody locus of points.

A lighting system using the combination of BSY and red LED devices referred to above to make substantially white light can be referred to as a BSY plus red or "BSY+R"
20 system. In such a system, the LED devices used include LEDs operable to emit light of two different colors. In one example embodiment, the LED devices include a group of LEDs, wherein each LED, if and when illuminated, emits light having dominant wavelength from 440 to 480 nm. The LED devices include another group of LEDs, wherein each LED, if and when illuminated, emits light having a dominant wavelength

from 605 to 630 nm. Each of the former, blue LEDs are packaged with a phosphor that, when excited, emits light having a dominant wavelength from 560 to 580 nm, so as to form a blue-shifted-yellow LED device. In another example embodiment, one group of LEDs emits light having a dominant wavelength of from 435 to 490 nm and the other
5 group emits light having a dominant wavelength of from 600 to 640 nm. The phosphor, when excited, emits light having a dominant wavelength of from 540 to 585 nm. A further detailed example of using groups of LEDs emitting light of different wavelengths to produce substantially white light can be found in issued U.S. Patent 7,213,940, which is incorporated herein by reference.

10 The various parts of an LED fixture according to example embodiments of the invention can be made of any of various materials. Heatsinks can be made of metal or plastic, as can the various portions of the housings for the components of a fixture. A fixture according to embodiments of the invention or portions of such a fixture can be assembled using varied fastening methods and mechanisms for interconnecting the
15 various parts. For example, in some embodiments locking tabs and holes can be used. In some embodiments, combinations of fasteners such as tabs, latches or other suitable fastening arrangements and combinations of fasteners can be used which would not require adhesives or screws. In other embodiments, adhesives, screws, bolts, or other fasteners may be used to fasten together the various components. The substrate and the
20 white reflective material can also be fastened together with snap fits, features in the metal substrate such as piercings and/or folds that hold the reflector in place, adhesives, or in any other fashion.

Although specific embodiments have been illustrated and described herein, those of ordinary skill in the art appreciate that any arrangement which is calculated to achieve

the same purpose may be substituted for the specific embodiments shown and that the invention has other applications in other environments. This application is intended to cover any adaptations or variations of the present invention. The following claims are in no way intended to limit the scope of the invention to the specific embodiments

5 described herein.

CLAIMS

1. A lighting system comprising:
 - a reflector to reflect light, wherein the reflector comprises a textured
5 surface including a material that is at least semi-specular when no texture is present; and
 - an LED light source to emit light, positioned so that at least 70 % of the
light is incident on the textured surface.
- 10 2. The lighting system of claim 1 wherein the reflector further comprises a metal substrate.
3. The lighting system of claim 2 wherein the textured surface further comprises
an imprinted pattern.
- 15 4. The lighting system of claim 3 wherein the material further comprises polycarbonate.
5. The lighting system of claim 4 wherein the imprinted pattern comprises a
20 prismatic pattern.
6. The lighting system of claim 5 wherein the LED light source further
comprises at least two groups of LEDs, wherein one group, if illuminated, would emit
light having a dominant wavelength from 435 to 490 nm, and another group, if
25 illuminated, would emit light having a dominant wavelength from 600 to 640 nm, one

group being packaged with a phosphor, which, when excited, emits light having a dominant wavelength from 540 to 585 nm.

7. The lighting system of claim 6 further comprising at least one lens plate
5 proximate to the LED light source.

8. A reflector configured to receive at least 70 % of light from an LED light source, the reflector comprising a surface including a material that is at least semi-specular when no texture is present.

10

9. The reflector of claim 8 wherein the surface further comprises an imprinted pattern.

10. The reflector of claim 9 further comprising a metal substrate.

15

11. The reflector of claim 10 wherein the imprinted pattern comprises a prismatic pattern.

12. The reflector of claim 11 wherein the prismatic pattern spatially varies
20 relative to a center of the reflector.

13. The reflector of claim 8 further comprising a roughened surface.

14. The reflector of claim 13 further comprising a metal substrate.

15. The reflector of claim 13 wherein a roughening of the surface spatially varies relative to a center of the reflector.

5 16. A method of retro-reflecting light into an illumination area, the method comprising:

energizing an LED light source;

directing at least 70 % of light from the LED light source to be incident on a textured surface of a reflector, wherein the surface comprises a material that is at least semi-specular when no texture is present and the material with texturing is fixed to a metal substrate; and

10

reflecting at least a portion of the light incident on the textured surface into the illumination area.

15 17. The method of claim 16 wherein the texturing comprises a roughened surface.

18. The method of claim 17 wherein the roughened surface varies relative to at least one of the LED light source and a center of the reflector.

20

19. The method of claim 16 wherein the texturing comprises a prismatic surface.

20. The method of claim 19 wherein the prismatic surface varies relative to at least one of the LED light source and a center of the reflector.

25

1/9

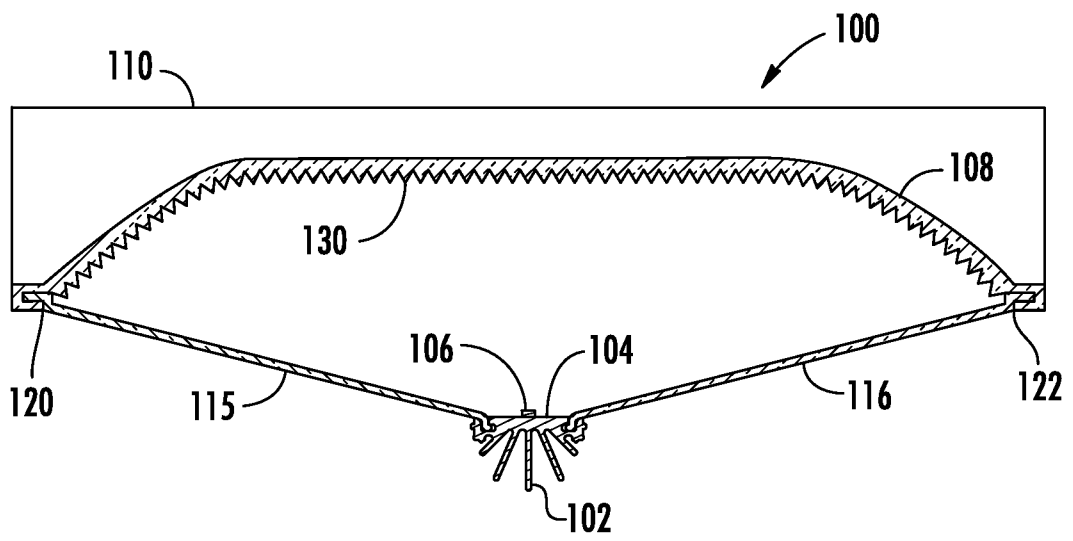
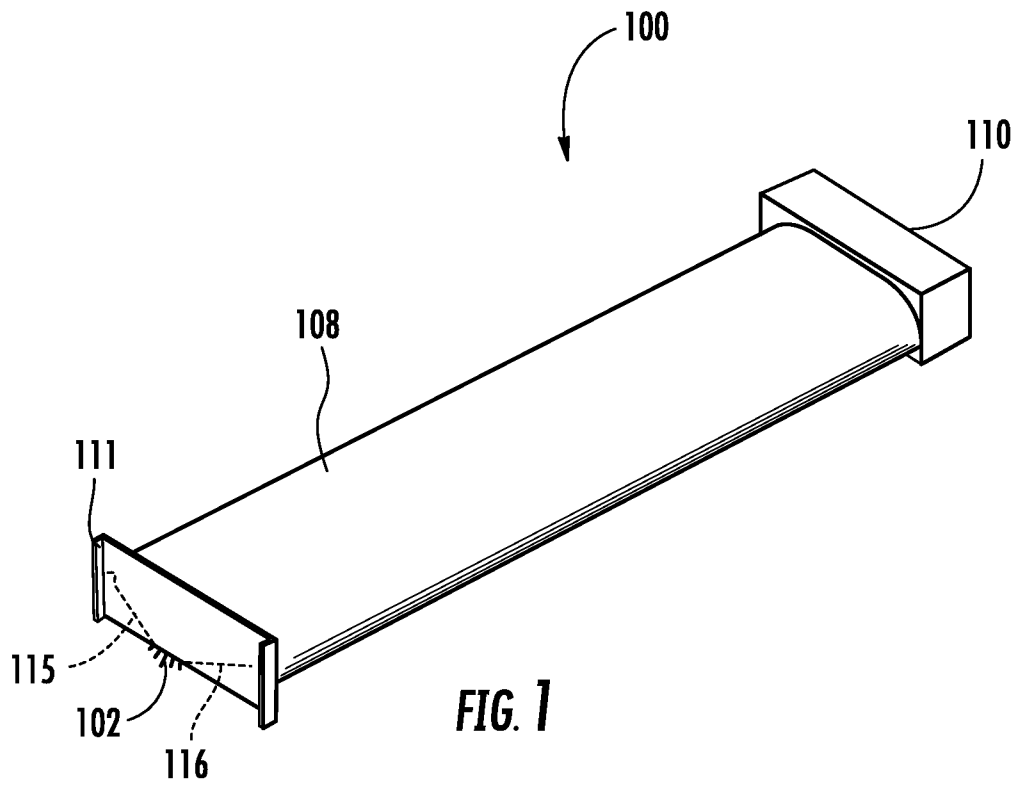

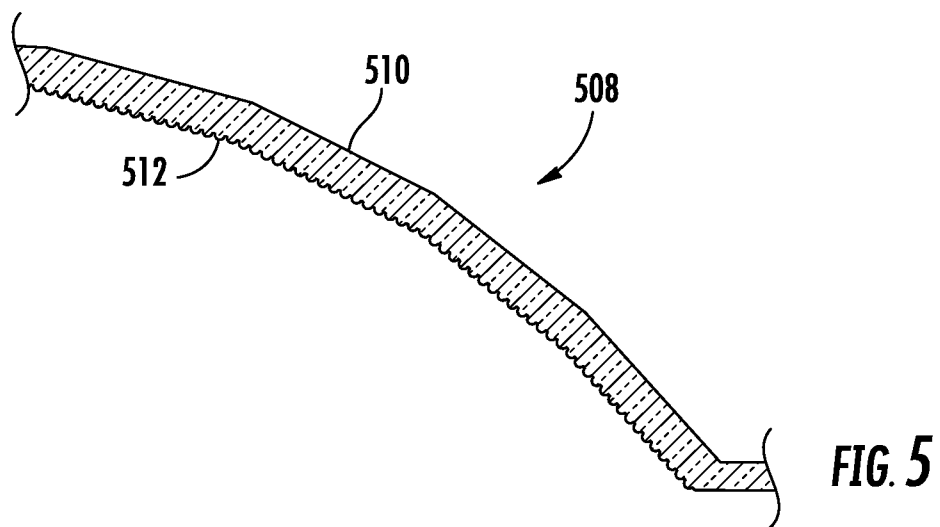
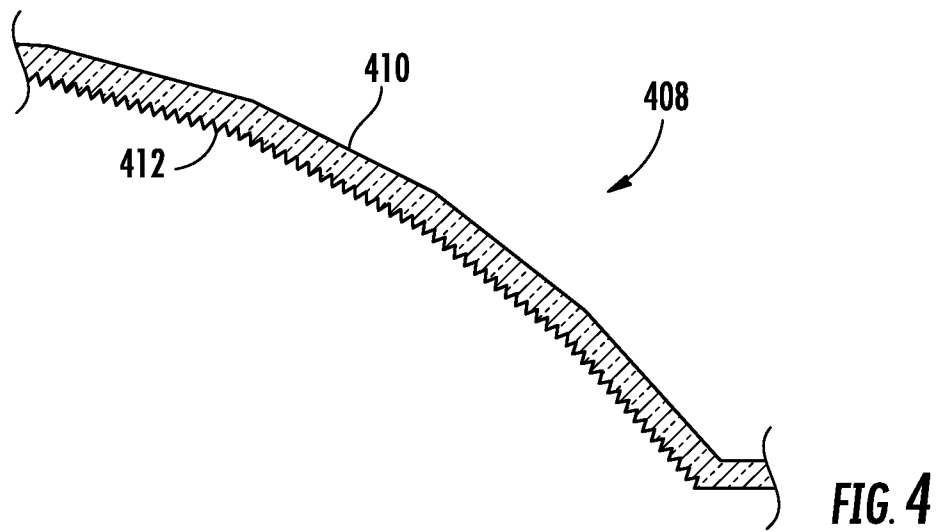
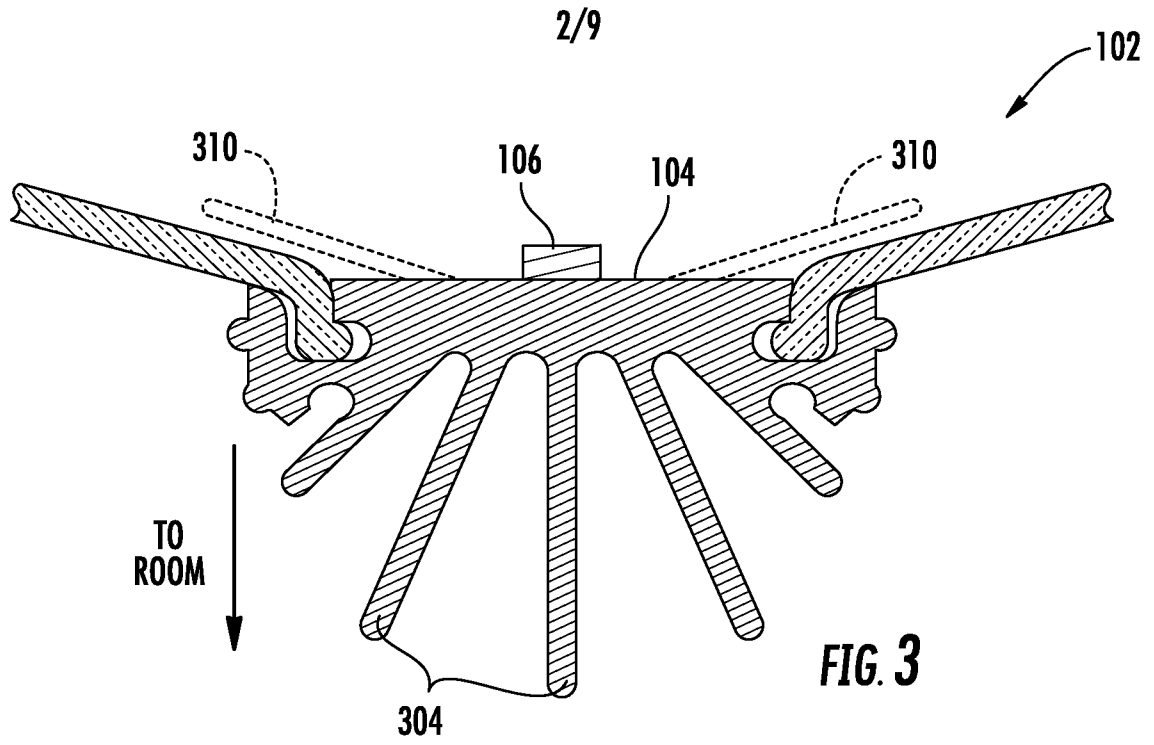

3/9

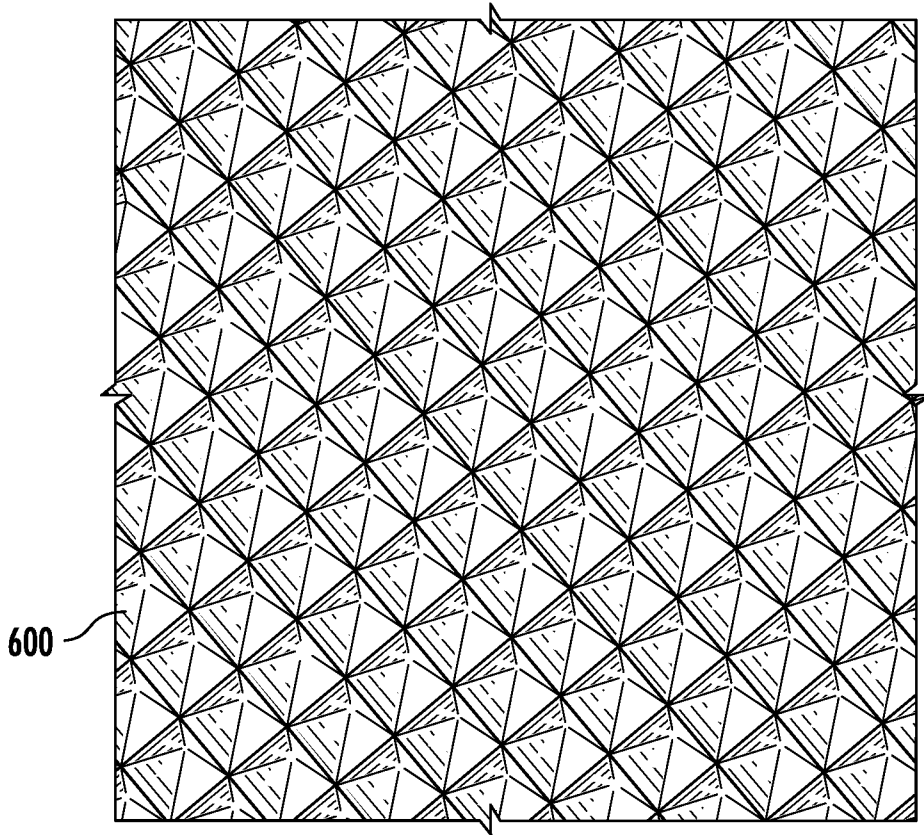

FIG. 6A

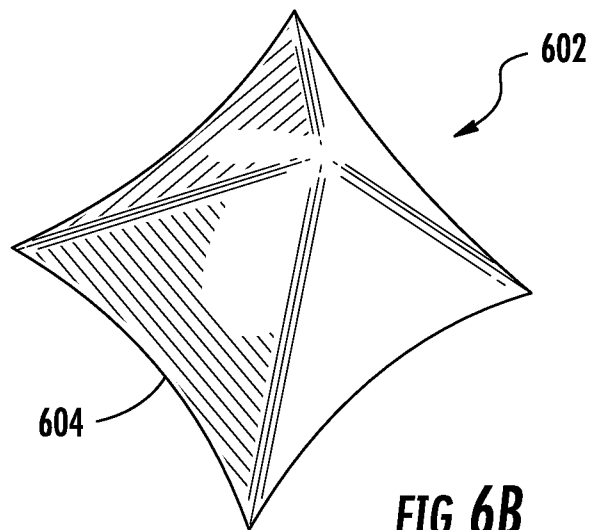

FIG. 6B

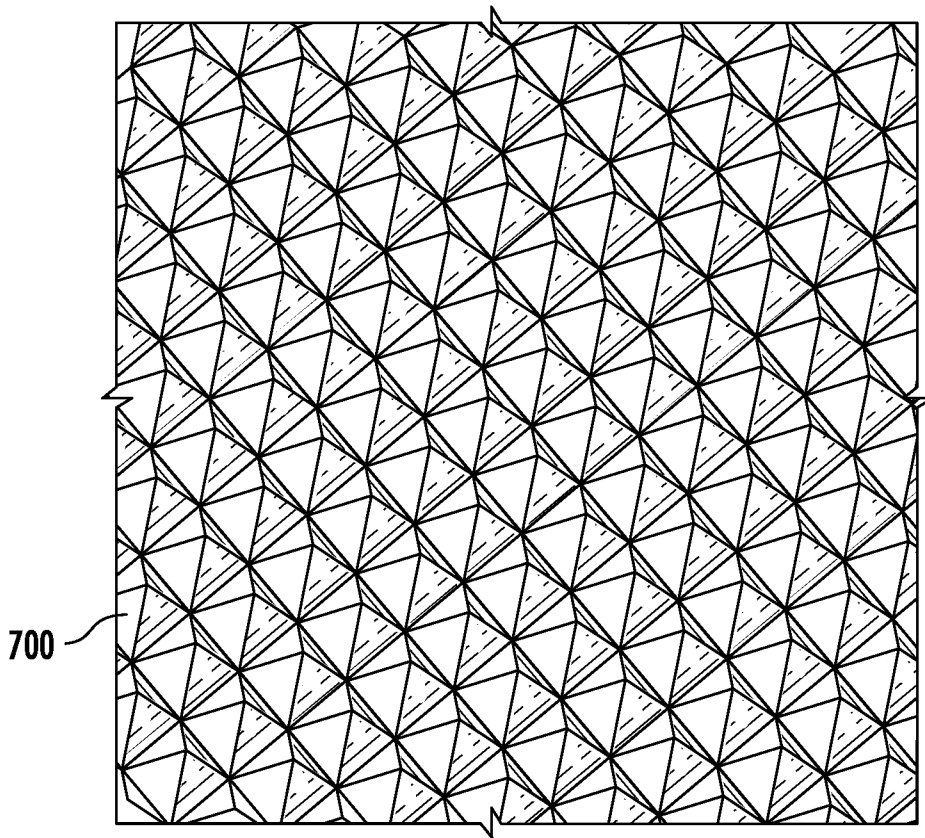

FIG. 7A

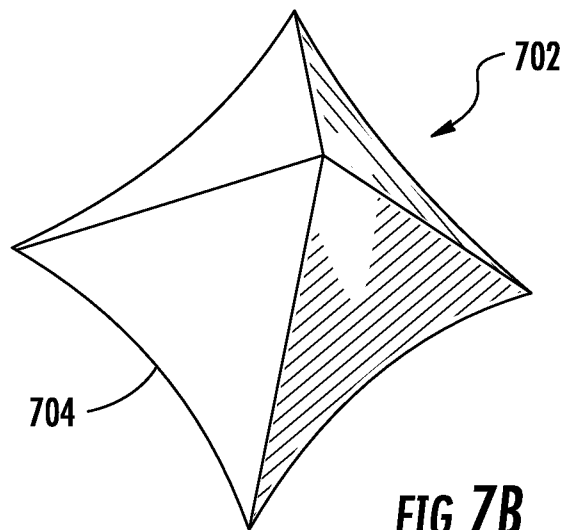

FIG. 7B

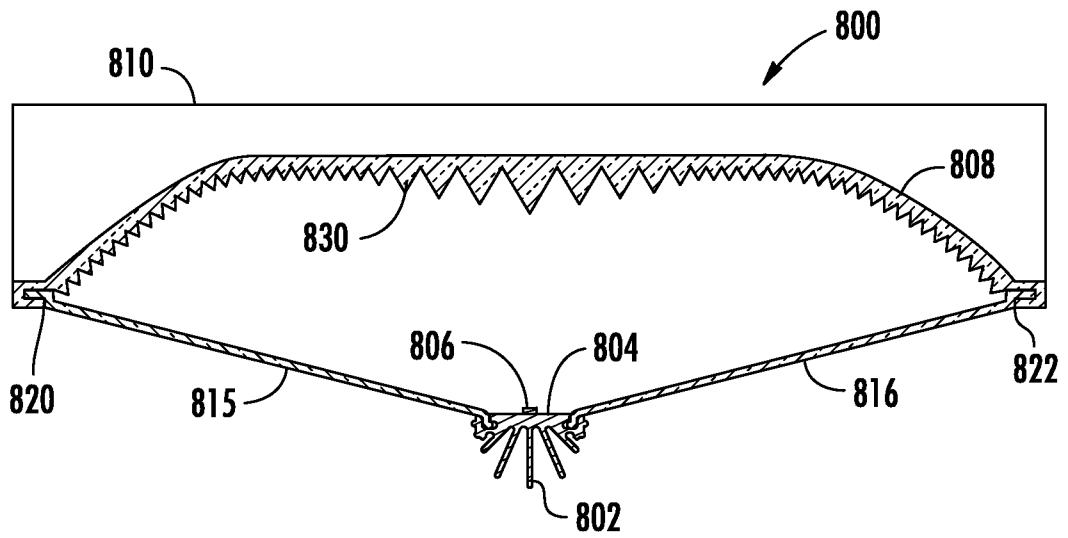
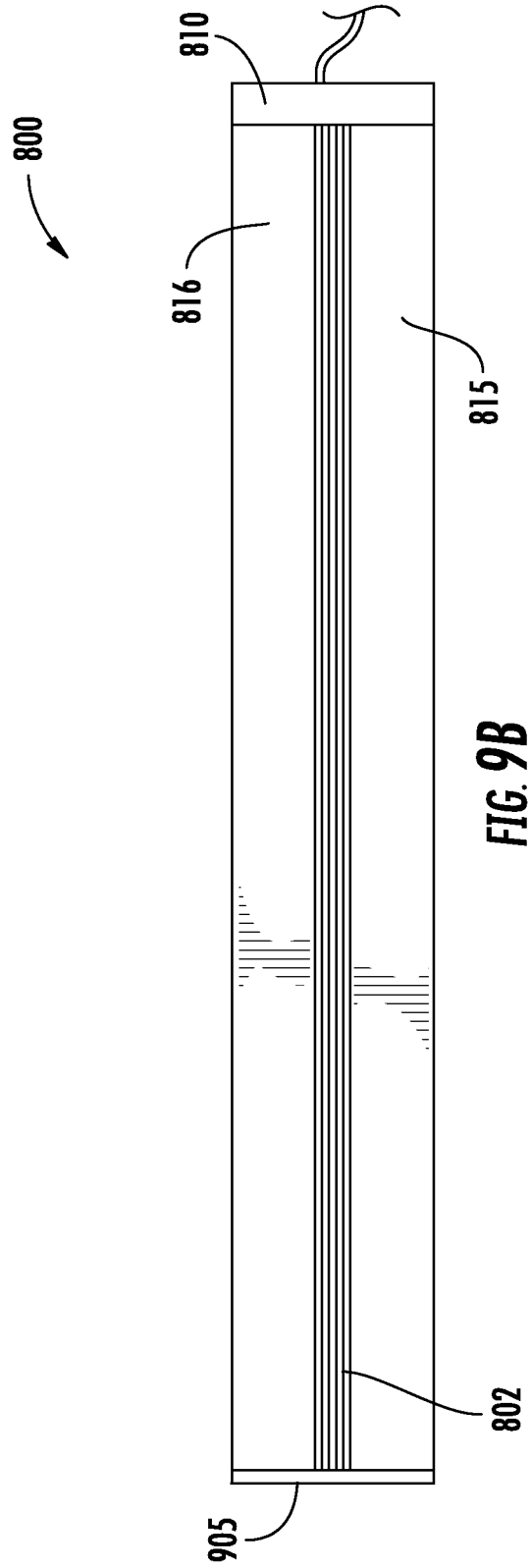
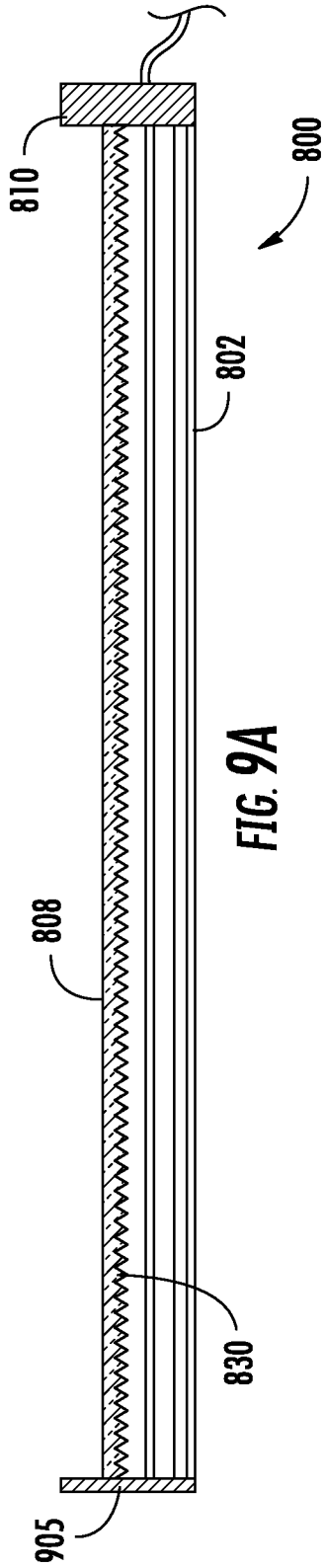

FIG. 8



7/9

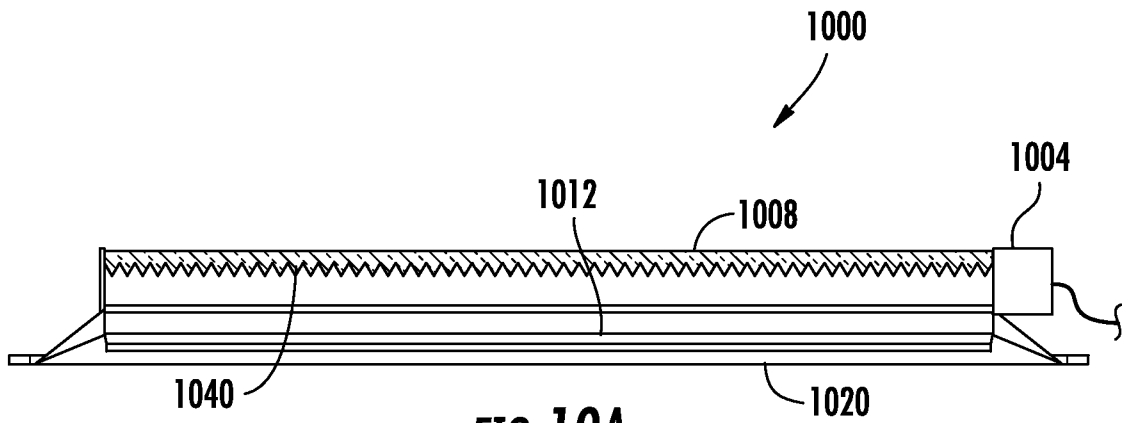

FIG. 10A

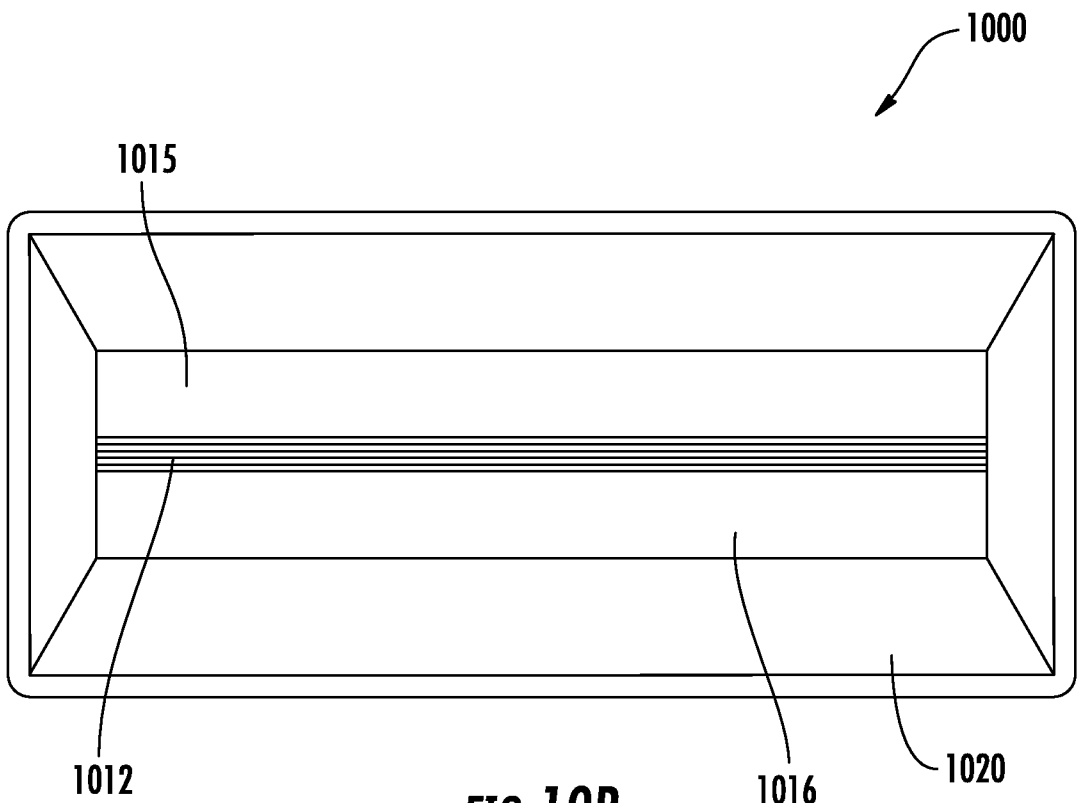

FIG. 10B

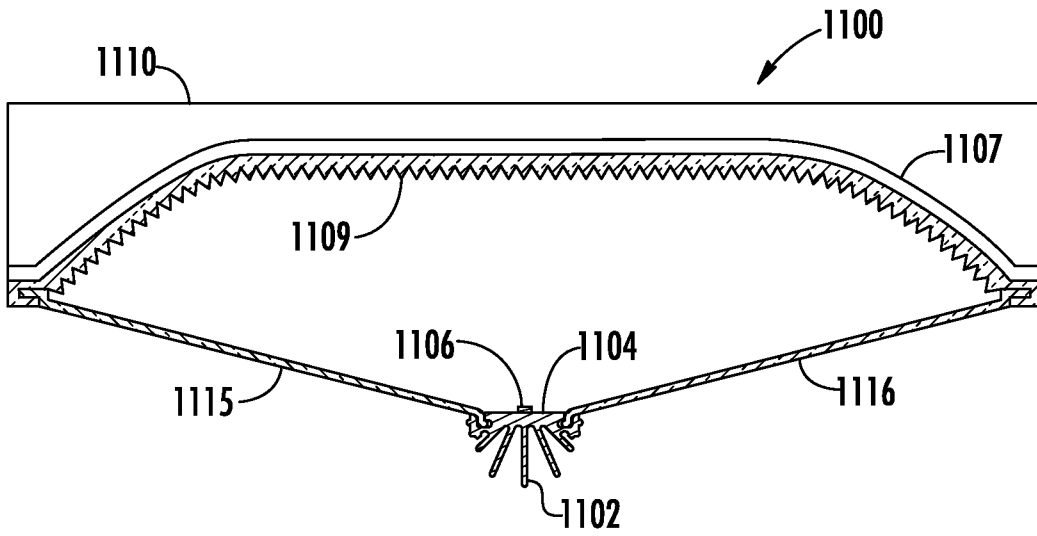

FIG. 11

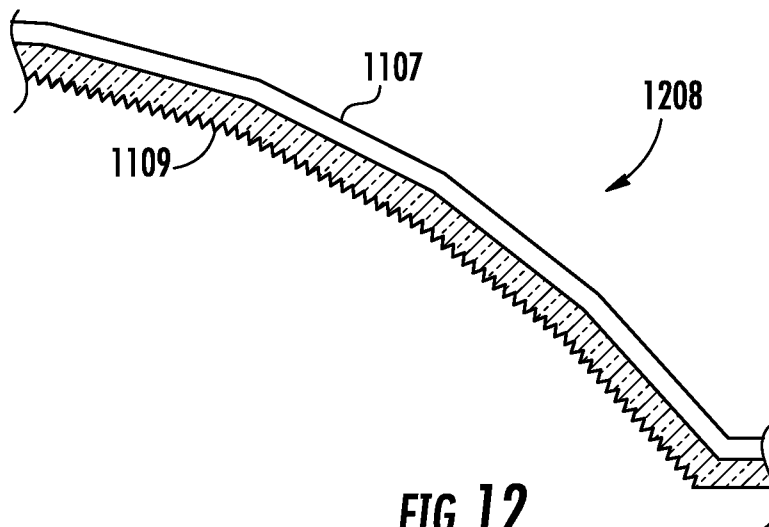

FIG. 12

9/9

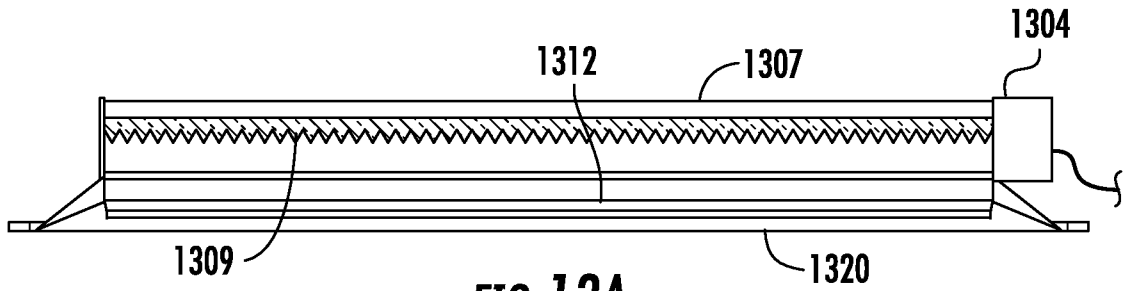

FIG. 13A

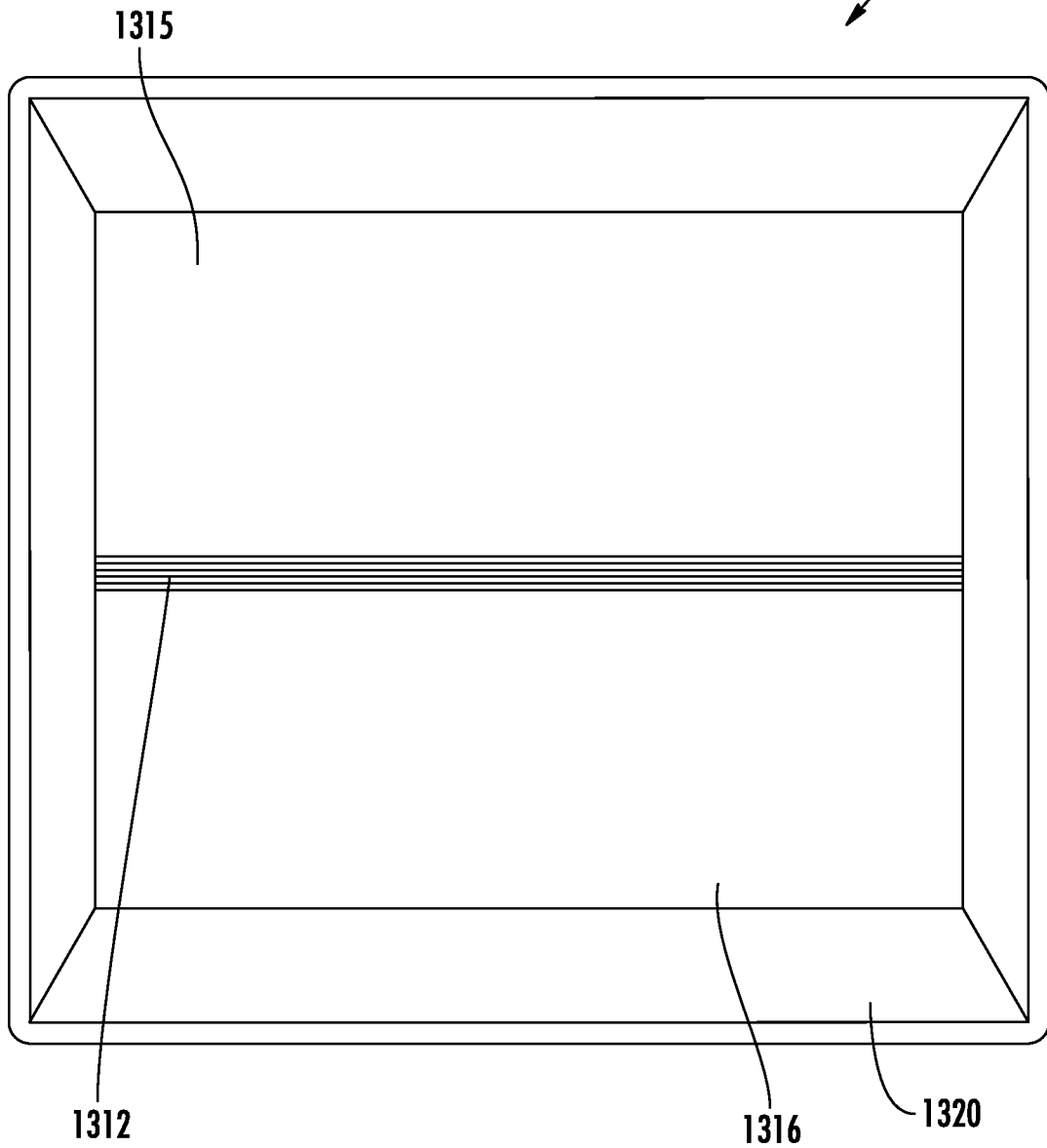
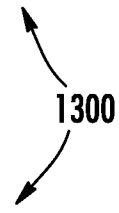

FIG. 13B