

S. N. HOUSE.  
 TENONING MACHINE.  
 APPLICATION FILED MAR. 30, 1910.

1,005,974.

Patented Oct. 17, 1911.

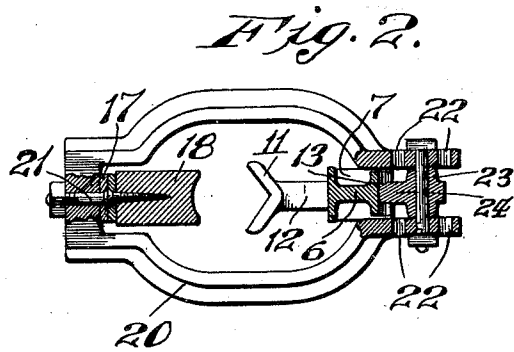
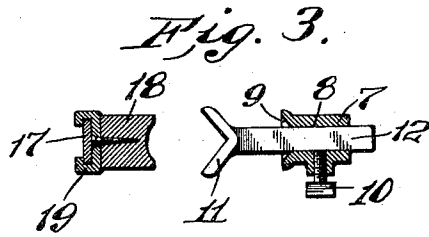
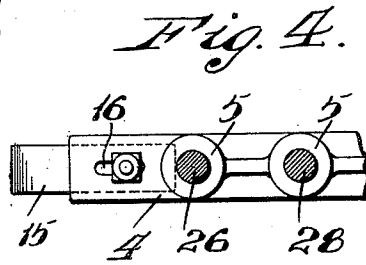
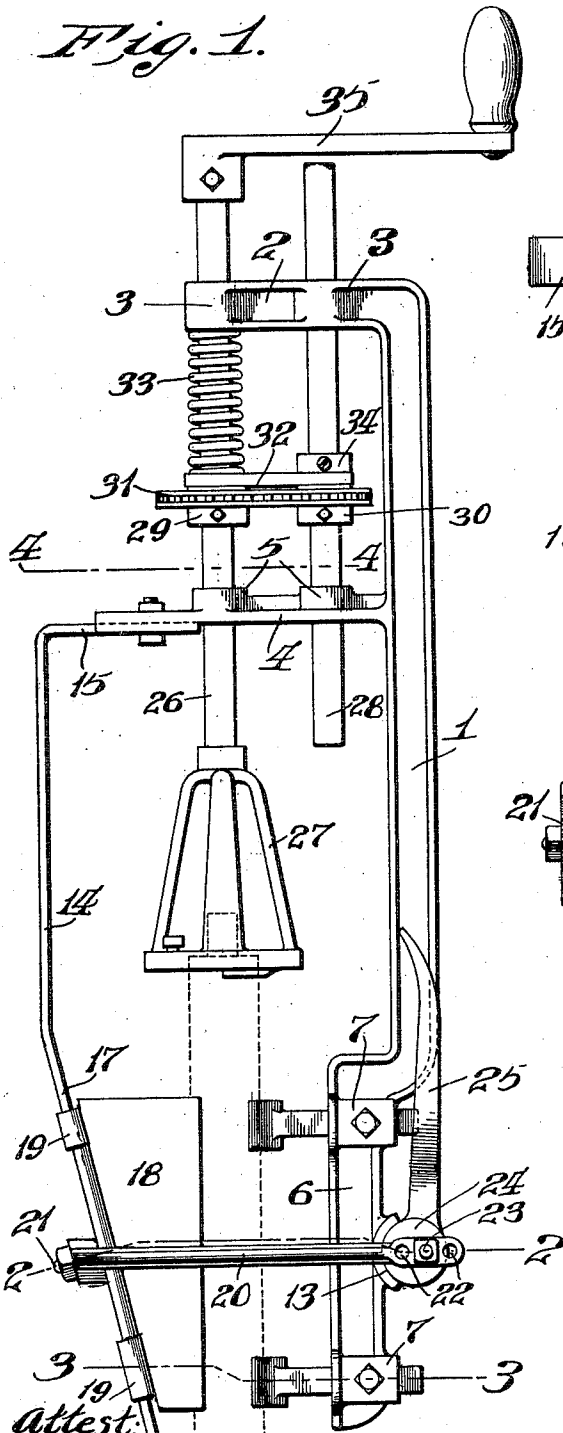

Attest:  
 L. G. W. Litcher.  
 E. L. Mallace.

Inventor:  
 Samuel N. House.  
 By Higdon & Langman  
 attys.

# UNITED STATES PATENT OFFICE.

SAMUEL N. HOUSE, OF ST. LOUIS, MISSOURI.

## TENONING-MACHINE.

1,005,974.

Specification of Letters Patent.

Patented Oct. 17, 1911.

Application filed March 30, 1910. Serial No. 552,458.

To all whom it may concern:

Be it known that I, SAMUEL N. HOUSE, a citizen of the United States, and resident of St. Louis, Missouri, have invented certain new and useful Improvements in Tenoning-Machines, of which the following is a specification containing a full, clear, and exact description, reference being had to the accompanying drawings, forming a part hereof.

My invention relates to improvements in tenoning machines, the object of my invention being to construct a novel frame for a tenoning machine, which frame may be readily attached to a spoke or other timber for forming a tenon on the end of the spoke and which frame may be readily and quickly adjusted to fit various sizes of spokes or timbers.

For the above purposes my invention consists in certain novel features of construction and arrangement of parts as will be hereinafter more fully described, pointed out in the claims and illustrated by the accompanying drawing, in which:

Figure 1 is an elevation of the complete tenoning machine the spoke or timber upon which the machine operates being shown in dotted lines; Fig. 2 is a sectional plan taken on the line 2—2 of Fig. 1 and illustrates the means for clamping the frame to the spoke; Fig. 3 is a detail, sectional plan taken on the line 3—3 of Fig. 1 and illustrates the spoke engaging members; and Fig. 4 is a detail, sectional plan taken on the line 4—4 of Fig. 1 and illustrates the bearings of the machine frame for the variable speed shafts and also illustrates the means whereby the upper ends of the frame members are adjusted laterally relative each other.

Referring by numerals to the accompanying drawing: 1 designates the main body portion of the frame and 2 an integral, right angled extension of the frame at its top, which extension is provided with bearings 3.

4 designates an integral extension of the frame paralleling the extension 2 and which extension is provided with bearings 5.

6 designates an offset portion of the frame and which is provided with integral enlargements 7 through which are formed rectangular openings 8 having flaring mouths 9, and 10 designates set screws which are carried by threaded seats on the enlargements 7.

11 designates the spoke engaging jaws

which are provided with integral angular stems 12 which are inserted through the enlargements 7 and secured against movement by means of the set screws 10.

13 designates a cam face formed integral upon the offset portion 6 of the frame and on the outside face thereof about midway between the enlargements 7.

14 designates a spring steel member of the frame arranged in opposition to the rigid or main body portion 1 of the frame. The member 14 is provided with a right angled extension 15 at its top, which extension is secured to and carried by the extension 4 of the frame.

To provide for the lateral adjustment of the member 14 relative the frame proper the extension 4 is slotted at 16 so that the extension 15 of the member 14 may be adjusted laterally of the frame proper. The member 14 is provided with an integral, inclined portion 17. Arranged for movement longitudinally of the angular portion 17 of the member 14 is a wedge shaped spoke engaging member 18. Secured to the member 18 are the guides 19, portions of which are arranged to embrace the inclined portion 17 of the member 14.

20 designates a substantially U-shaped frame, the body portion of which is secured to the portion 17 of the member 14 by means of the bolt 21. The outer free ends of the arms of the frame 20 are each provided with a series of alining apertures 22. Pivotaly mounted upon the bolt 23 which is inserted through a pair of the apertures 22 is a cam 24 having an integral handle 25, the cam being arranged to engage in the cam face 13. Arranged to operate in the outermost part of the bearings 3 and 5 is a shaft 26 and carried by the shaft 26 is a tool 27 having the usual cutter heads for forming tenons on the ends of spokes or other timbers. Arranged in the innermost pair of bearings 3 and 5 is a shaft 28.

29 and 30 designate sprocket wheels which are secured to the shafts 26 and 28. Embracing the sprocket wheels is a chain 31.

32 designates a link resting upon the hub sections of the sprocket wheels and embracing the shafts 26 and 28.

33 designates an expansive coil spring impinging between the extension 2 of the frame and the link 32 and is coiled about the shaft 26, the spring being provided for the feed of the tool when cutting. Resting

upon the link 32 and embracing the shaft 28 is a collar 34 secured against longitudinal movement relative the shaft.

35 designates a crank arranged for attachment to either one of the shafts 26 or 28. By such an arrangement of shafts and gearing it is obvious that the tool may be rotated in a direct manner by securing the crank upon the shaft 26 or if it be desired to decrease the speed of the tool the crank may be attached to the shaft 28, a rotation of which will impart rotary movement to the shaft 26 bearing the tool through the sprocket wheels and chain. The two shafts are free to move vertically in the frame and by reason of the link 32 and collar 34 the shafts will be moved vertically simultaneously.

It is obvious by reason of the construction of the frame and the spoke engaging members that a great variety of adjustments to fit various sized timbers or spokes is possible and that by reason of the sliding wedge-shaped spoke engaging member 18 the frame is readily and quickly applied to a spoke.

In the practical operation of the machine the spoke or timber upon which a tenon is to be formed is held horizontally in any common manner and the spoke engaging members 11 are adjusted in the proper position and the whole machine is placed over the spoke with both of the members 11 in engagement with the spoke. If the spoke be a tapering spoke then one of the members 11 must be set closer to the machine frame than the other. The member 18 is then moved downwardly over the frame so as to snugly fit the spoke, the lever 25 is then moved and the cam operating against the

face 13 will draw the U-shaped member, thus rigidly clamping the member 18 to the spoke. The tool 27 is then brought over the end of the spoke and is rotated by a manipulation of the crank 35.

I claim:

1. In a tenoning machine, a rigid frame having right angled extensions provided with bearings in which a tenon-forming tool is mounted, spoke engaging members carried by the frame, a yielding frame member, a wedge-shaped member carried by the yielding member and arranged for movement lengthwise thereof, and means for drawing the wedge-shaped member and the yielding member toward and locking it to the machine frame proper, substantially as shown and for the purposes stated.

2. In a tenoning machine, the combination with a suitable tenon forming tool, of a spoke holding device comprising a rigid frame member, spoke engaging devices laterally adjustable relative the rigid member, a yielding member arranged in opposition to the rigid member and having an inclined free end, a wedge-shaped spoke engaging device adjustably carried by the inclined free end of said yielding member, and means for drawing and holding the spoke engaging devices in positions to firmly secure a spoke therebetween.

In testimony whereof, I have signed my name to this specification, in presence of two subscribing witnesses.

SAMUEL N. HOUSE.

Witnesses:

E. E. LONGAN,  
E. L. WALLACE.