



US 20050247460A1

(19) **United States**

(12) **Patent Application Publication**  
**Luebke**

(10) **Pub. No.: US 2005/0247460 A1**

(43) **Pub. Date: Nov. 10, 2005**

(54) **HAND DRILL ATTACHMENT**

**Publication Classification**

(76) Inventor: **Thomas M. Luebke**, Menomonee Falls,  
WI (US)

(51) **Int. Cl.7** ..... **B25D 1/00**

(52) **U.S. Cl.** ..... **173/2; 173/20**

Correspondence Address:

**QUARLES & BRADY LLP**  
**411 E. WISCONSIN AVENUE**  
**SUITE 2040**  
**MILWAUKEE, WI 53202-4497 (US)**

(57) **ABSTRACT**

A power hand drill has a subsurface object locator for detecting the presence of an object beneath a surface being probed with the locator. The drill has a housing with a flat accessory mounting surface having a pair of attachment tabs. The locator has a locator housing with a flat base and a pair of key hole slots engaged with the tabs for detachably mounting the locator housing to the accessory mounting surface of the drill housing. The locator includes sensing circuitry contained within the locator housing for detecting subsurface objects and has an object indicator mounted to the locator housing and connected to the sensing circuitry for indicating the presence of a subsurface object. A contoured surface on the locator housing provides a handrest for gripping when operating the drill.

(21) Appl. No.: **11/179,969**

(22) Filed: **Jul. 12, 2005**

**Related U.S. Application Data**

(63) Continuation of application No. 09/684,518, filed on Oct. 10, 2000, now Pat. No. 6,284,644.

(60) Provisional application No. 60/212,867, filed on Jun. 20, 2000.

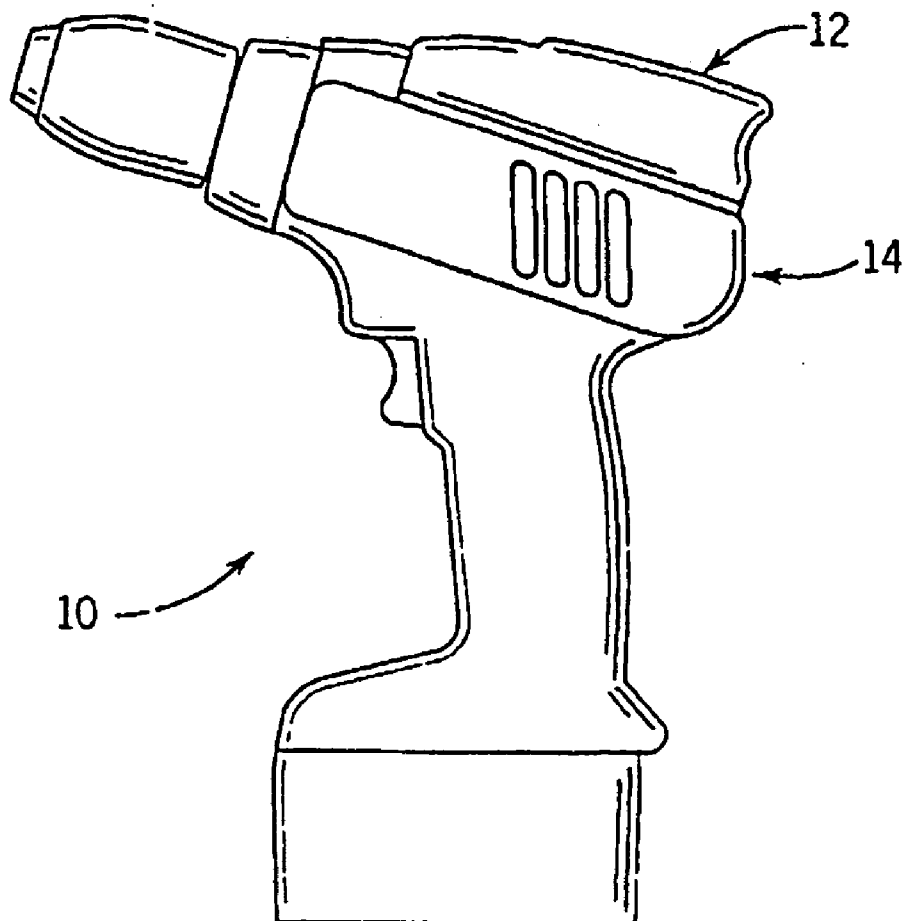

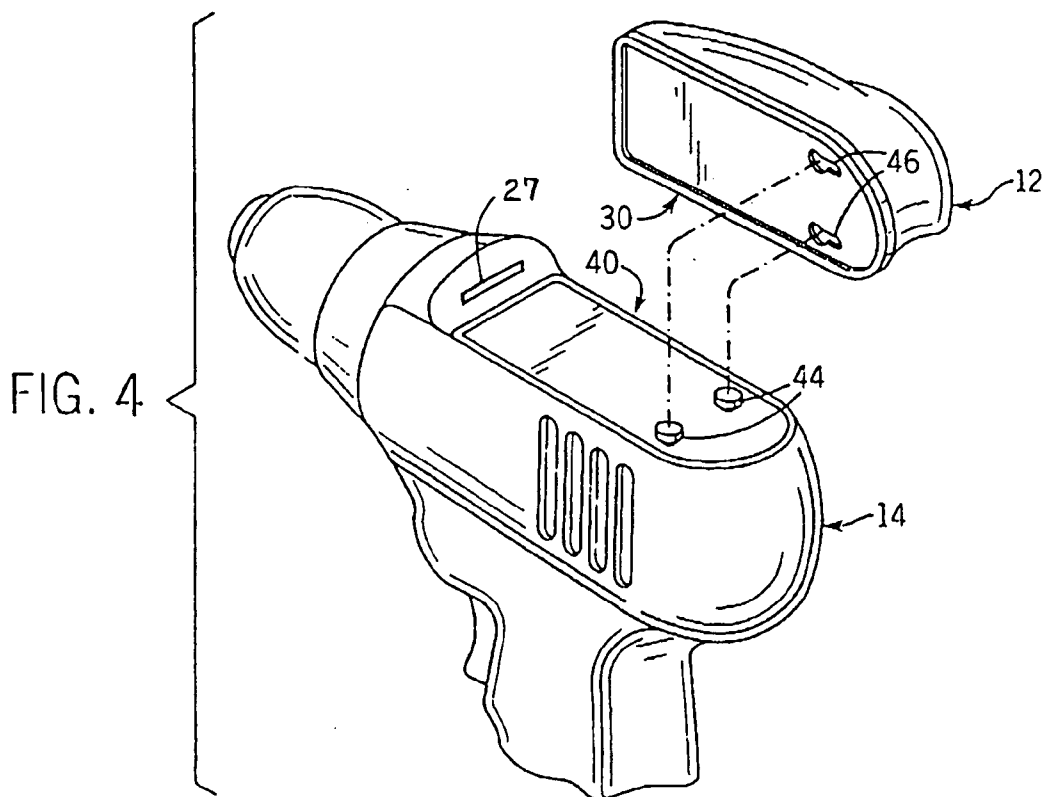
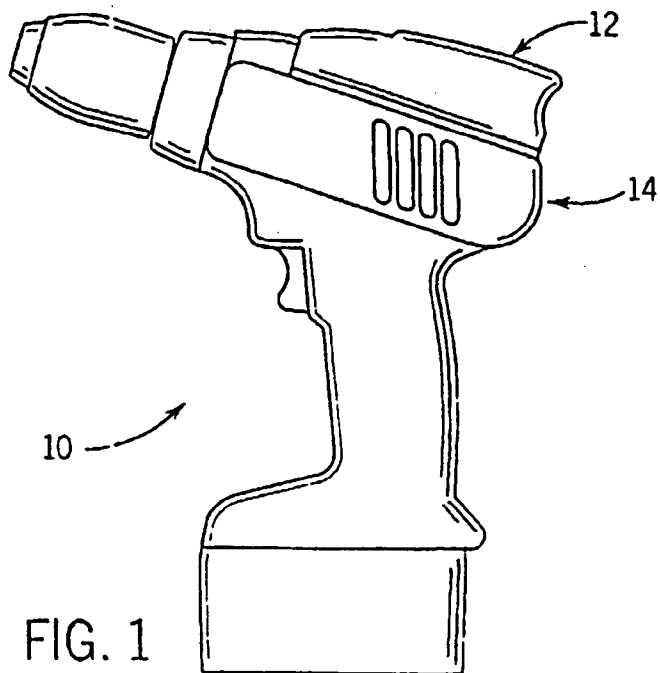

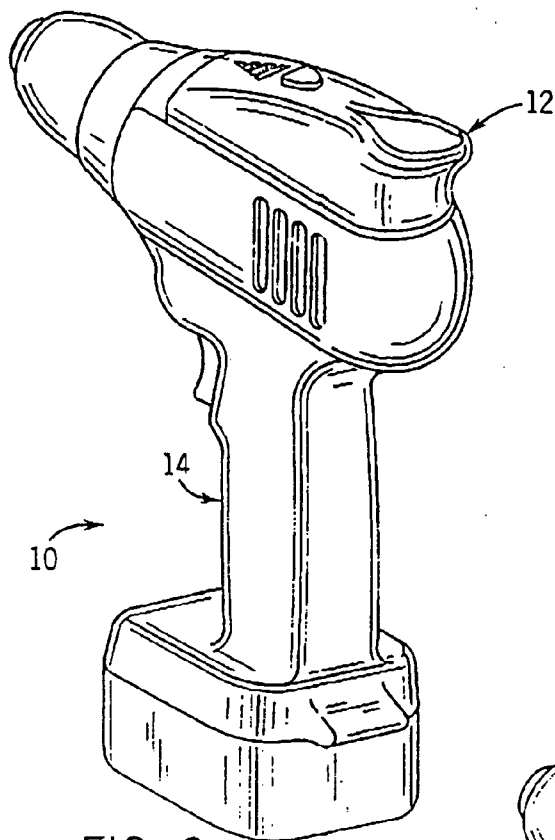

FIG. 2

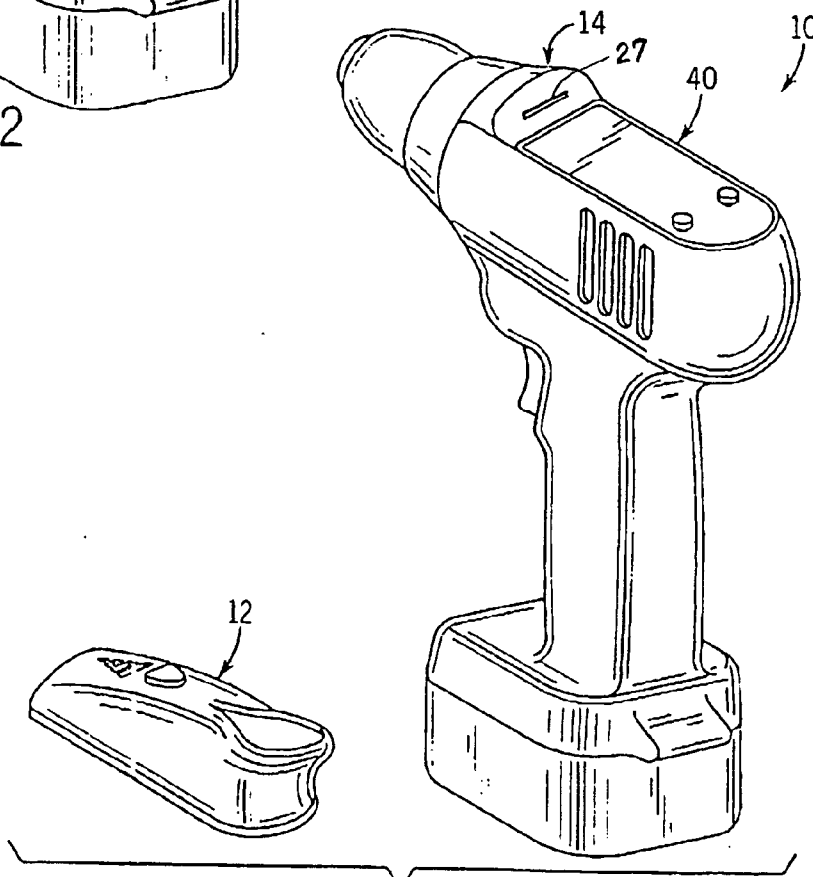
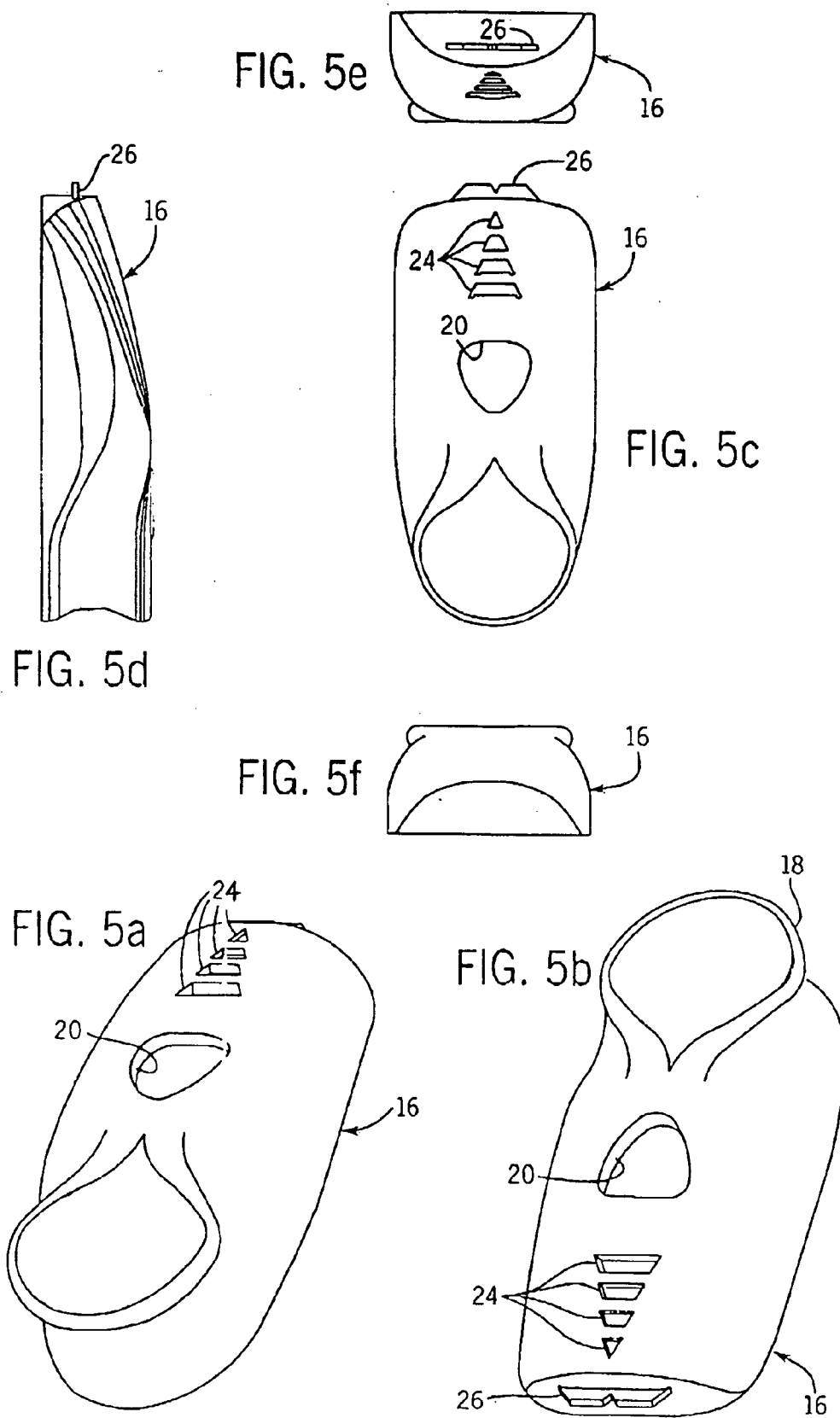

FIG. 3



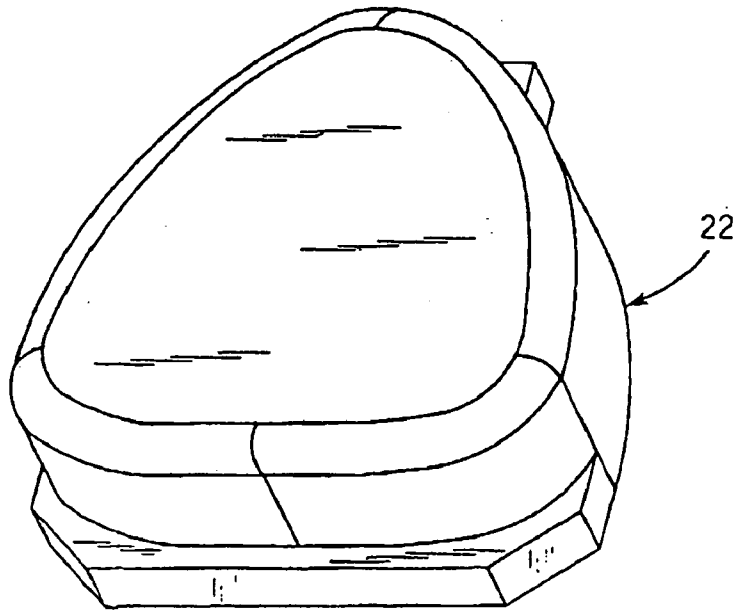

FIG. 6a

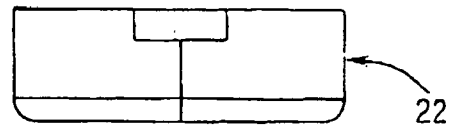

FIG. 6d

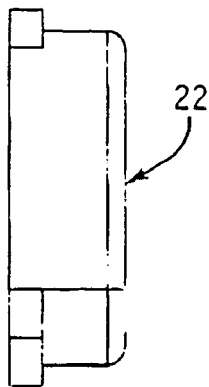

FIG. 6c

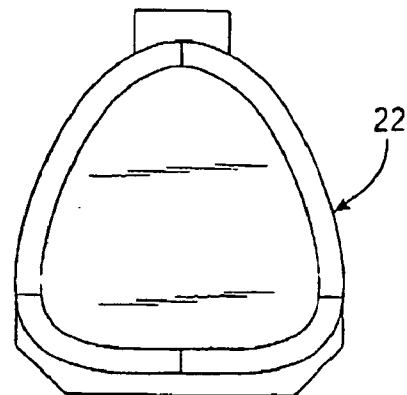
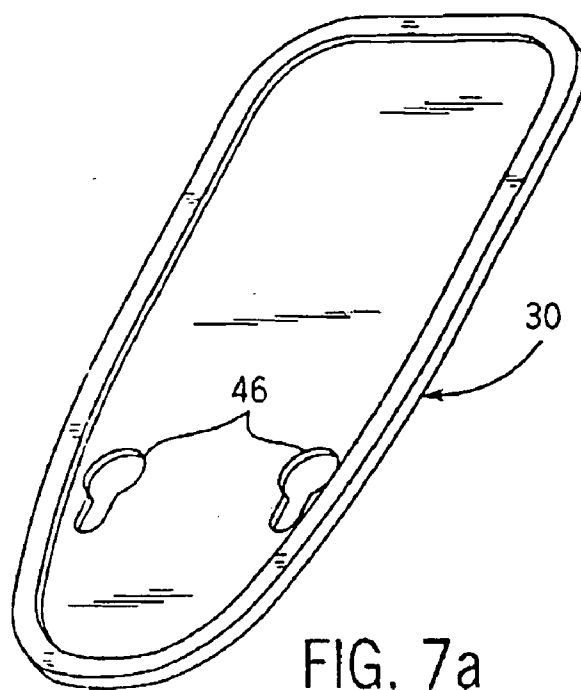
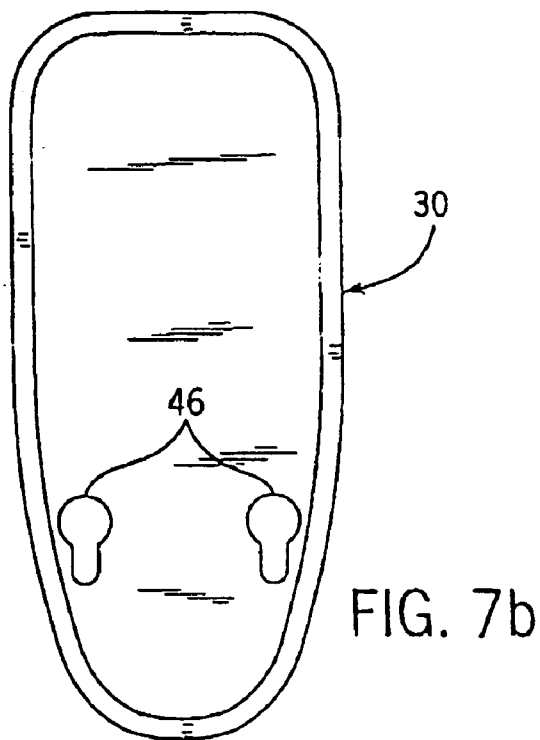
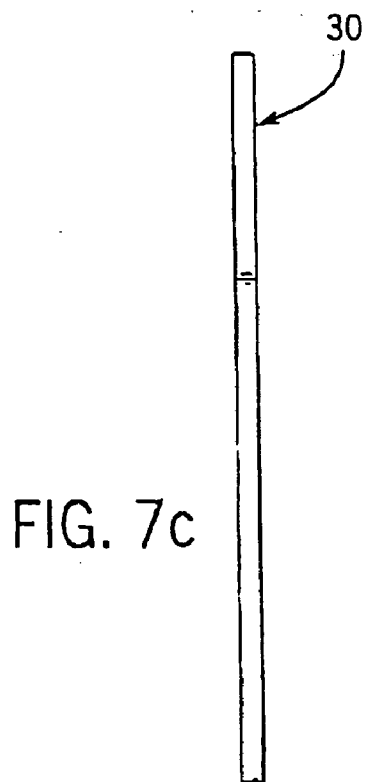
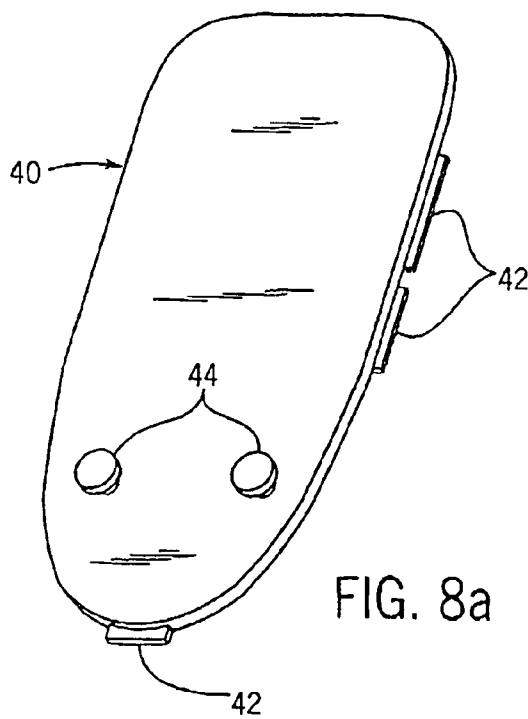
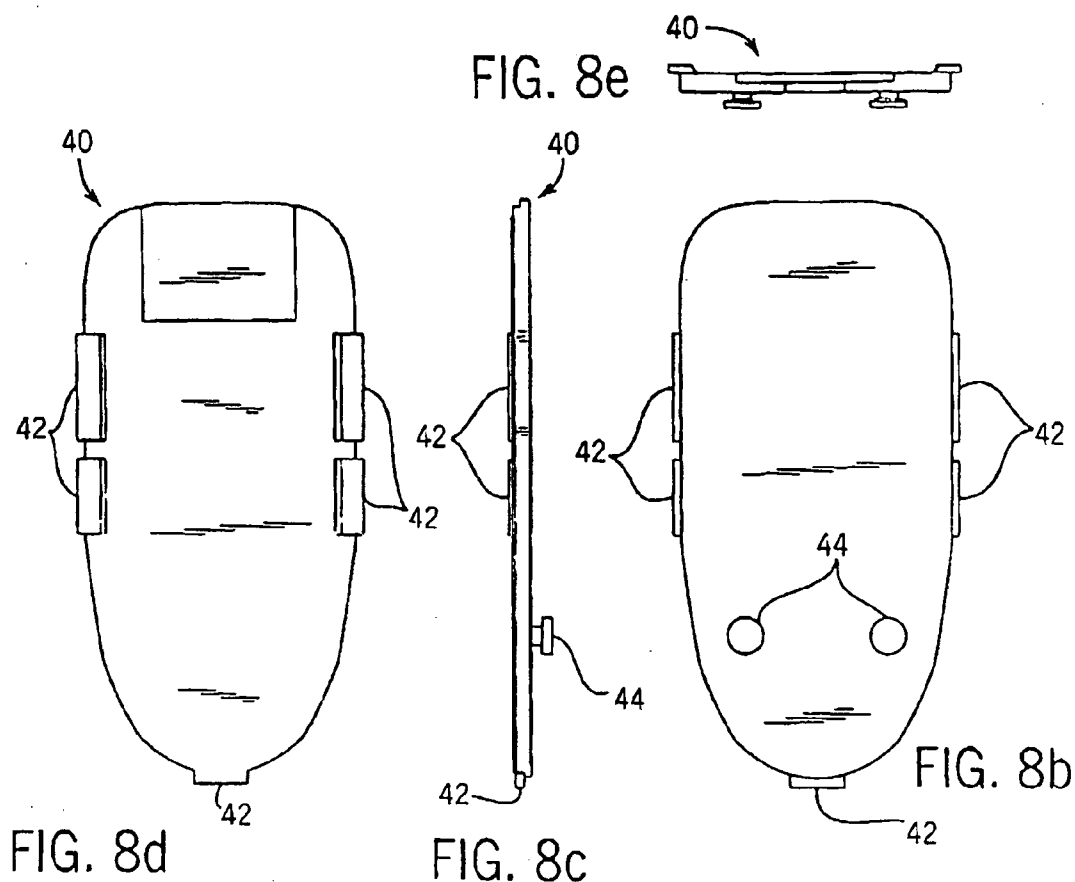

FIG. 6b





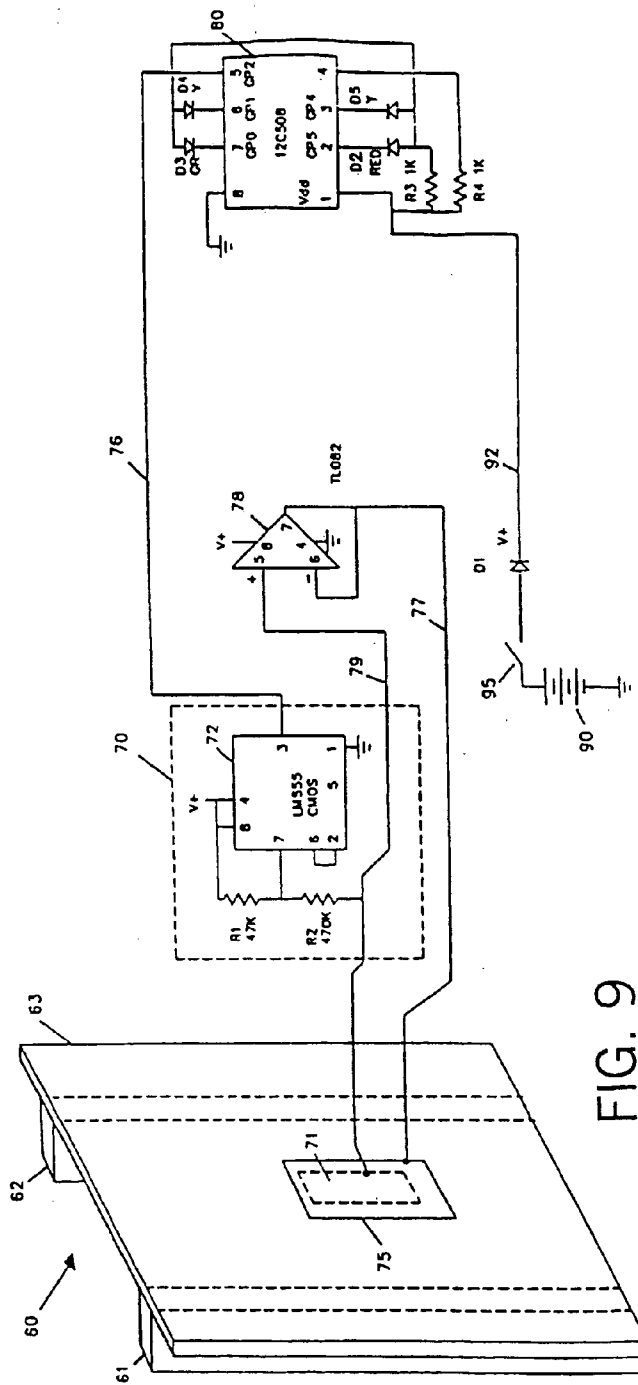
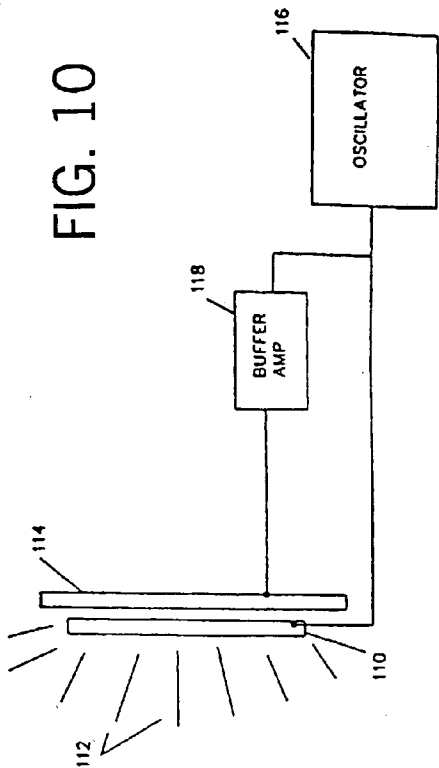

FIG. 10

FIG. 9



## HAND DRILL ATTACHMENT

### CROSS-REFERENCE TO RELATED APPLICATIONS

[0001] This application is a continuation of U.S. patent application Ser. No. 09/684,518, filed Oct. 19, 2001, which claims the benefit of U.S. provisional application Ser. No. 60/212,867 filed Jun. 20, 2000.

### STATEMENT REGARDING FEDERALLY SPONSORED RESEARCH/DEVELOPMENT

[0002] Not applicable.

### FIELD OF THE INVENTION

[0003] This invention relates to attachments for hand drills, and in particular to a subsurface object locator attachment to a hand drill, sometimes known as a stud finder, for detecting a stud or other object behind an opaque surface, such as wall board.

### BACKGROUND OF THE INVENTION

[0004] Carpenters, electricians, do-it-yourselfers and others are often faced with the problem of locating the position of the wall studs behind the wall board material forming the wall surface. They are interested in hanging pictures, drilling holes and so on. However after the walls are finished and painted the location of the hidden substructure (i.e. the studs) is not visually detectable. The same is true of finding the location of hidden wooden frames in furniture and boats from the outside surface of the structure.

[0005] Handheld electronic stud finders are well known. For example, U.S. Pat. No. 4,099,118 issued Jul. 4, 1978 discloses an electronic wall stud sensor which is suitable for detecting a wall stud behind a wall surface. This stud sensor uses electronic sensing circuitry to accurately determine the location of the stud behind the walls by activating the circuitry, holding the device near or against the wall and slowly moving the device until the stud is detected.

[0006] When using a stud finder, it is often necessary to also use a power drill and screw driving device for making holes in the wall and mounting a fastener. Since the two devices are often used together it would be convenient and efficient to have a single device which would perform both functions. Unfortunately, the sensing electronics of the stud finder can be affected by other electronics making it less accurate, and thus, cannot be incorporated into the drill without suitable shielding. Moreover, the sensing circuitry needs to be held near or against the surface being probed, which would be difficult if made a part of the drill.

### SUMMARY OF THE INVENTION

[0007] The invention provides a new device capable of efficiently finding the location of hidden objects or substrata such as studs, joists and other similar objects below the surface of walls, floors and similar type structures. The device may also be used to find the location of braces, wood frames or other substructures in wooden furniture such as tables and cabinets, wooden boats and similar type structures.

[0008] Specifically, the invention provides a subsurface object locating accessory for a hand drill having a drill

housing. The locator includes an accessory housing having a substantially flat surface and an attachment member for detachably mounting the accessory housing to the drill housing. The locator has sensing circuitry contained within the accessory housing for detecting subsurface objects and an object indicator mounted to the accessory housing and connected to the sensing circuitry for indicating the presence of a subsurface object.

[0009] In a preferred form, the locator housing is shaped to provide a handrest for operating the drill. The substantially flat surface interfaces with the drill and an attachment member is located adjacent the substantially flat surface and forms part of a connection joining the accessory housing to the drill housing.

[0010] The invention also provides a hand drill, which may be corded or cordless, that has a subsurface object locator detachably incorporated into its housing. The subsurface object locator is attached to the housing of the drill with a snap or other appropriate detachable fit, so that it may be carried to the work site as part of the drill, detached from the drill at the work site and used to probe a wall surface, and reattached to the drill housing when probing of the wall surface is finished.

[0011] The locator can be moved across the wall to locate subsurface objects like wall studs. It senses any change in the dielectric constant of the wall material caused by the location of a subsurface object. It contains automatic circuitry for sensing the frequency change caused by the object and measuring the frequency shift. An LED (light emitting diode) display indicates the presence of the object.

[0012] The foregoing and other objects and advantages of the invention will appear in the detailed description which follows. In the description, reference is made to the accompanying drawings which illustrate a preferred embodiment of the invention.

### BRIEF DESCRIPTION OF THE DRAWINGS

[0013] FIG. 1 is a perspective view of a cordless hand drill including a subsurface object locator of the invention;

[0014] FIG. 2 is a view similar to FIG. 1 from a different angle;

[0015] FIG. 3 is a view similar to FIG. 2 but with the subsurface object locator removed from the drill housing;

[0016] FIG. 4 is a view similar to the preceding views but showing how the subsurface object locator is reattached to the drill housing;

[0017] FIGS. 5a-5e are perspective (FIGS. 5a and 5b), top (FIG. 5c), side (FIG. 5d), front (FIG. 5e) and rear (FIG. 5f) views of the main housing of the subsurface object locator;

[0018] FIGS. 6a-6d are perspective (FIG. 6a), top (FIG. 6b), side (FIG. 6c), and front (FIG. 6d) views of a button for the subsurface object locator;

[0019] FIGS. 7a-7c are perspective (FIG. 7a), top (FIG. 7b), and side (FIG. 7c) views of a bottom cover for the subsurface object locator;

[0020] FIGS. 8a-8e are perspective (FIG. 8a), top plan (FIG. 8b), side (FIG. 8c), bottom (FIG. 8d), and rear (FIG.

8e), views of a mounting plate which forms a part of the housing of the drill and detachably mounts the subsurface object locator;

[0021] FIG. 9 is a schematic diagram of a circuit for practicing the invention; and

[0022] FIG. 10 is a schematic diagram illustrating the operation of the circuit.

#### DETAILED DESCRIPTION OF THE PREFERRED EMBODIMENT

[0023] Referring to FIGS. 1-4, a drill 10 of the invention includes a subsurface object locator 12 detachably mounted to the drill housing 14. The drill 10 as illustrated is a cordless drill, although it could be provided with a cord for power with the locator 12 in the same position. Referring particularly to FIGS. 5a-5e, the locator 12 has a main housing 16 which is contoured to fit to the shape of the housing 14 and provide a handrest 18 at the rear of the housing 16 which is contoured to fit a user's hand and provide a surface for thrusting against the rear of the drill with the users hand so as to operate the drill. The main housing 16 also has a buttonhole 20 into which the button 22 (FIGS. 6a-6d) fits for turning on the locator. The housing 16 also has indicator light openings 24 which are covered with an appropriate lens so that an indication of when the locator 12 senses a subsurface object can be given to the user by illuminating LEDs through the windows 24 as more fully described below. In addition, the housing 16 has a tongue 26 extending from its front end which fits into a slot 27 of the housing 14 to help secure the locator 12 and align it to the contours of the housing 14.

[0024] As shown in FIGS. 7a-7c, a back plate 30 is attached to the bottom of the housing 16 by any suitable means, such as glue, ultrasonic welding or other means. A sensor plate 71 (see FIG. 9) is made substantially as large as the bottom plate 30, to maximize the sensitivity of the subsurface object locator. The circuitry of the locator is housed between the bottom plate 30 and the housing 16, and is operated by the button 22. Thus, to sense a subsurface object, the locator 12 is removed from the drill housing 14, and its bottom is slid over the surface being sensed while holding down the button 22. The indicator lights visible through openings 24 then indicate the edges of the subsurface object.

[0025] Referring to FIGS. 8a-8e, and also FIG. 3 and FIG. 4, a mounting plate 40 for mounting the locator 12 is fixed to the drill housing 14 by any suitable means. As illustrated, the plate 40 is fixed with a snap fit, having tabs 42 around its periphery which fit with corresponding slots or grooves in housing 14 to secure the plate 40. Any other suitable attachment means such as screws, adhesive or other means may also be used.

[0026] The plate 40 has two projections 44 with enlarged heads which fit into keyhole shaped openings 46 in the plate 30 to secure the locator 12 to the housing 14. As mentioned above, the tongue 26 of the housing 16 fits into a correspondingly shaped opening in the housing 14 when the projections 44 are fit into the large ends of the openings 46 and the locator 12 is slid forward so as to secure it with a friction fit of the projections 44 entering the small ends of the openings 46. Any other detachable connection of the locator 12 to the housing 14 could also be used.

[0027] Shown in FIG. 9 is a portion of a wall structure 60, studs 61, 62 and wall board 63 to be illustrative of one way of operating the invention. In this case, it is desired to locate the positions of the hidden studs 61 and 62. Although any suitable circuitry can be used, one possible circuit (shown in FIG. 9) includes a metallic sensor plate 71 connected to a CMOS oscillator 70 which produces a square (or rectangular) wave output. The circuit consists of a timer IC 22, the sensor plate and resistors. The frequency of the oscillator 70 is determined by IC 72, the values of resistors R1 and R2 and the capacitance presented by the plate 71.

[0028] Referring to FIGS. 9 and 10, when the sensor plate 71 is above a section of the wall with no studs it will cause the oscillator 70 to run at a first frequency (f1). When the sensor is above a section of the wall that has a stud below it the oscillator will have a different frequency (f2). The capacitance of the plate 71 is determined by the surrounding medium including the wall material, the studs, the circuit and the person holding the device. It is desirable to reduce the stray capacitance as much as possible since this will improve the sensitivity of the plate 71. The capacitance of plate 71 is influenced considerably by the operator and the housing of the device.

[0029] Capacitance is related to its potential with respect to other objects. If an additional plate 75 is introduced in the vicinity of plate 71 with the same potential as plate 71, it will reduce the "stray" effects. This improves the sensitivity of the plate 71 and allows it to sense further into the wall.

[0030] The potential of plate 71 changes as the oscillator 70 operates. In a typical situation it may vary from 0 to 5 volts in amplitude. Hence the guard plate 75 must have its potential vary in the same way. This is accomplished by using a buffer amplifier 78, with a gain of one, which has the voltage of the sensor plate 71 at its input and produces a near exact replica of it at its output, which is connected to plate 75 via line 77. Hence plate 75 is driven at the same potential as plate 71.

[0031] As shown in FIG. 10, the sensor plate 71 is connected to the oscillator 70 and the guard plate 75 is driven from amplifier 78 so it has the same potential as the sensor plate 71. The E-field 100 is now prevented from going in the direction of the guard plate 75. This is because both plates are at the same potential and by electrical laws there can be no E-field between conductors of the same potential. With fewer E-field lines, there is less capacitance of sensor plate 71. Hence it will be more responsive to dielectric changes in the direction opposite to the guard plate 75. The guard plate 75 may be somewhat larger than the sensor plate 71 so as to extend beyond the edges of the sensor plate 71, which redirects the E-field lines emanating from the edges of the sensor plate 71 in the direction toward the surface being probed.

[0032] The microprocessor circuit 80 is programmed to measure the frequency difference f1 minus f2, which can be done by any suitable means. For example, the microprocessor circuit 80 will typically include a counter. The counter can be programmed to count the number of times the oscillator output signal to the microprocessor goes high in a certain period, which yields a measure of the frequency of the oscillator output. If the frequency difference between the first measured frequency and the subsequently measured frequencies exceeds an amount deemed sufficient to indicate the presence of a stud, an LED is turned on.

[0033] The circuit **80** actually has four LEDs **D2**, **D3**, **D4** and **D5** that can be activated at different amounts of frequency change. More or fewer LEDs could be used as indicators depending upon resolution and cost considerations. The circuit is powered by batteries **90** (e.g., four 1.5V pancake cells) through protective diode **D1** (e.g., a 1N270 diode) and line **92**. Resistor **R3** is used to limit the current in the LEDs. Resistor **R4** is used for a power on reset for circuit **80**. Button **22** operates switch **95** to enable power to circuit from the battery **90** to circuit **80**.

[0034] Although visual LED indicators **D2-D5** are described here, it should be clear that audible indicators could be used as well. For example, different audible tones could be produced corresponding to various frequency differences encountered in scanning the wall, as the leading edge of a stud was approached, the frequency could go up, and as the trailing edge of the stud was passed the frequency could go down. In fact, there are occasions where audible indications may be better, such as in cases where the visible indicators may be hard to see.

[0035] As the sensor is moved along the wall the frequency changes. As the frequency decreases, the circuit **80** senses this change and turns on one or more of the LEDs **D2-D5**. The LEDs could be turned on so as to overlap in on-times or not. In the preferred embodiment, the on-times do not overlap to preserve battery power.

[0036] To use the device described, the sensor plate **71** is placed on or in close proximity to the wall where there are no studs and the button **22** is pressed which closes the switch **95**. This causes circuit **80** to be activated and it will measure the first frequency **f1** from the oscillator **70** and save it in memory. After this step is performed, which takes less than a second, the lowest LED **D3** (green) comes on and stays on as a power indicator, while the button **22** is pressed. This signals to the operator that the device can now be moved across the wall being probed. As the sensor is moved across the wall the circuit **80** is continuously measuring the second or subsequent frequency **f2** from oscillator **70** and comparing it to the first frequency **f1** by taking the frequency difference. When the difference exceeds a first threshold, the next LED up, LED **D4** (amber) will be lit and LED **D3** will go out. When the difference exceeds a second threshold, greater than the first threshold, the next LED **D5** (amber) will be turned on and LED **D4** will go out. When the difference exceeds a third threshold, greater than the second threshold and which indicates the presence of the leading edge of the stud, the highest LED **D2** (red) goes on and the LED **D5** goes out. LED **D2** stays on as the thickness of the stud is traversed by the device. When the trailing edge of the device is reached, the LEDs go off and on in the reverse sequence. Thus, a user trying to find a stud, will mark the leading edge of the stud when LED **D2** comes on, and will mark the trailing edge of the stud when the LED **D2** goes off.

[0037] When a user first puts the device against a wall or other surface to be probed, there is no way of telling if it is initially placed over a stud or other subsurface object or not. The device assumes that it is not. However, if by chance it is, then the subsequently found frequency difference will be negative and unless special provision is made in the programming of the microprocessor, an error will result. It is an easy matter, however, to program the microprocessor so that if the **f1-f2** frequency difference is found to be negative, it

means that the device was initially placed over a stud or other subsurface object. The device could be programmed to flash the LEDs or beep a buzzer in that event to alert the user to start over, placing the device in a different initial position.

[0038] Referring again to **FIGS. 1-3** and **5d**, the drill housing houses a motor along an axis substantially parallel to the mounting surface **40**, and a handle portion along an axis substantially perpendicular to the mounting surface **40**.

[0039] The housing **16** of the locator **12** slopes upward from the front end adjacent the tongue **26**. The sloped portion provides a grip allowing the operator to grasp the housing **16** of the locator **12** and to slide the housing **16** rearwardly for removal from the drill housing **14**.

[0040] A preferred embodiment of a drill including an attachment of the invention has been described in particular detail. Many modifications and variations of the embodiment described will be apparent to those skilled in the art. Therefore, the invention is not limited to the embodiment described but should be defined by the claims which follow.

We claim:

1. A drill accessory housing for housing an accessory for use with a hand drill having a drill housing, the drill accessory housing comprising:

a substantially flat bottom surface including an attachment member adapted to be slidably and detachably received by the drill housing; and

an upper surface that slopes upward in the direction from a front of the accessory housing to the rear of the housing, wherein when the drill accessory housing is installed on the drill housing, said upper surface provides a grip by which the accessory housing can be grasped to slide the housing rearwardly to release it from the drill housing.

2. The drill accessory of claim 1, further comprising:

sensing circuitry contained within the accessory housing for detecting subsurface objects probed by said accessory; and

an object indicator connected to the sensing circuitry for indicating the presence of a subsurface object.

3. The drill accessory of claim 2, wherein the object indicator comprises a plurality of indicator lights.

4. The drill accessory of claim 2, wherein the sensing circuitry activates a first indicator light as the accessory approaches a subsurface object.

5. The drill accessory of claim 3, wherein the sensing circuitry activates a second indicator light as the accessory senses an edge of a subsurface object.

6. The drill accessory of claim 3, wherein the indicator lights are color-coded to provide a first coded indication when the accessory is approaching a subsurface object, and a second coded indication when the accessory detects an edge of the subsurface object.

7. The drill accessory of claim 1, wherein the mounting surface is sized and dimensioned to be received on a substantially flat surface in the drill housing.

8. A hand drill including a drill accessory, comprising:

a drill housing including an accessory mount defined in an upper surface of the drill housing, the accessory mount including a substantially flat mounting surface and a first attachment member; and

a drill accessory housing having a substantially flat bottom surface including a second attachment member adapted to be slidably engaged with the first attachment member and an upper surface sloping upward from a front portion of the accessory housing;

wherein the drill accessory housing is detachably mounted adjacent to the accessory mounting surface of the drill housing.

9. The hand drill of claim 8, wherein the drill accessory comprises a subsurface object locator.

10. The hand drill of claim 8, wherein the drill accessory includes sensing circuitry contained within the accessory housing for detecting subsurface objects probed by said accessory.

11. The hand drill of claim 10, further comprising an object indicator connected to the sensing circuitry for indicating the presence of a subsurface object.

12. The hand drill of claim 11, wherein the object indicator comprises a plurality of lights.

13. The hand drill of claim 12, wherein the lights are color-coded.

14. A hand drill, comprising:

a housing having an upper portion for receiving a motor extending along a first axis and a lower handle portion extending along a second axis substantially perpendicular to the first axis;

a flat mounting surface formed in the upper portion of the housing and extending along the first axis; and

an attachment member coupled to the flat mounting surface and adapted to slidably receive a drill accessory adjacent to the flat mounting surface and to couple the accessory to the housing.

15. A hand drill including a detachable subsurface object locator accessory for detecting the presence of an object beneath a surface being probed with the locator, comprising:

a drill housing defining an accessory mount along an upper surface of the housing, the accessory mount having a substantially flat mounting surface and including a first attachment member;

a subsurface object locator housing having a substantially flat bottom surface for sliding along a surface to be probed, the substantially flat bottom surface including a second attachment member slidably received by and coupled to the first attachment member; a sensing circuitry contained within the subsurface locator housing for detecting subsurface objects; and

an object indicator connected to the sensing circuitry for indicating the presence of a subsurface object.

16. The hand drill of claim 15, wherein the sensing circuitry further comprises a switch for resetting the subsurface object detector.

17. The hand drill of claim 15, wherein the object indicator comprises a visual indicator.

18. The hand drill of claim 15, wherein the object indicator comprises an audio indicator.

19. The hand drill of claim 15, wherein the visual indicator comprises a plurality of color-coded light emitting diodes.

20. The hand drill of claim 19, wherein the visual indicator comprises at least one of an amber, a red, and a green light emitting diode.

21. The hand drill of claim 18, wherein the subsurface object locator housing includes an upper surface that slopes upward from a front portion of the drill housing.

\* \* \* \* \*