

(19)



(11)

EP 4 335 325 B1

(12)

EUROPEAN PATENT SPECIFICATION

(45) Date of publication and mention of the grant of the patent:
25.12.2024 Bulletin 2024/52

(51) International Patent Classification (IPC):
A47C 1/034^(2006.01) A47C 7/38^(2006.01)

(21) Application number: **23179469.4**

(52) Cooperative Patent Classification (CPC):
A47C 1/0342; A47C 7/38

(22) Date of filing: **15.06.2023**

(54) **SLIDING SEAT FOR SOFA OR ARMCHAIR, INTEGRATED WITH ADJUSTABLE BACKREST**
SCHIEBESITZ FÜR SOFA ODER SESSEL INTEGRIERT MIT VERSTELLBARER RÜCKENLEHNE
SIÈGE COULISSANT POUR CANAPÉ OU FAUTEUIL, INTÉGRÉ À UN DOSSIER RÉGLABLE

(84) Designated Contracting States:
**AL AT BE BG CH CY CZ DE DK EE ES FI FR GB
GR HR HU IE IS IT LI LT LU LV MC ME MK MT NL
NO PL PT RO RS SE SI SK SM TR**

(30) Priority: **06.09.2022 IT 202200018216**

(43) Date of publication of application:
13.03.2024 Bulletin 2024/11

(73) Proprietor: **M.F. International S.r.l.
51039 Quarrata (PT) (IT)**

(72) Inventor: **Mati, Barbara
51030 Serravalle Pistoiese (PT) (IT)**

(74) Representative: **Fanfani, Stefano
Fanfani S.R.L.
Via Giovanni Bovio 19
50136 Firenze (IT)**

(56) References cited:
**WO-A1-2012/053022 WO-A1-2013/061259
WO-A1-2014/162292 DE-A1- 102008 028 623**

EP 4 335 325 B1

Note: Within nine months of the publication of the mention of the grant of the European patent in the European Patent Bulletin, any person may give notice to the European Patent Office of opposition to that patent, in accordance with the Implementing Regulations. Notice of opposition shall not be deemed to have been filed until the opposition fee has been paid. (Art. 99(1) European Patent Convention).

Description

Technical field

[0001] The present invention relates to the technical field of furnishings, in particular to the field of so-called upholstered seating such as sofas or armchairs.

[0002] More specifically, the present invention relates to an assembly consisting of an extractable sliding seat integrated with an adjustable-conformation backrest.

Present status of the art

[0003] It is necessary to first note that in the present patent text the term "seating" is used to identify items specially shaped for sitting, with particular reference to armchairs and sofas.

[0004] Armchairs and sofas are large, comfortable upholstered seating with a backrest and usually also with armrests or lateral sides, also generally covered with upholstery, intended to accommodate one or more persons. Such articles are known to have a dual function: on the one hand, they allow people to sit in a more comfortable and relaxing manner than a chair, and on the other hand, they are furnishing elements, used to embellish and decorate a room.

[0005] It is also to be noted that in the present patent text the term "seat" refers to a seating portion arranged substantially horizontally, above which one sits, and from which the backrest and armrests elevate.

[0006] In the search for greater comfort, special types of reclining seating with a mechanism commonly referred to as "recliner" or "relax" have been developed; we habitually refer to such seating as simply "recliner armchair" (or "relax armchair") or "recliner sofa" ("relax sofa").

[0007] The "recliner" or "relax" mechanism allows the user to change the arrangement of the seating to achieve a more relaxed and more restful position, basically lying down, by reclining the backrest backward while causing the seat to move forward and the footrest to rise. Such a mechanism can be operated manually by means of a leverage, or by using an electric motor built into the structure of the armchair or sofa.

[0008] Seating of the aforementioned type, however, are functional only in case the user wishes to assume a "conventional" posture, that is, positioning himself or herself in the centre of the seating with the body aligned with the longitudinal axis of the seating and with the head resting on the backrest. However, often the user prefers unconventional or somehow slouched postures: in some circumstances the user prefers to have his or her head slightly elevated and bent forward, for example, in order to be able to read a book; in other cases the user prefers to assume an oblique or crooked posture with respect to the seating, for example because he or she finds such a position more restful or in case he or she wishes to look towards a television screen or towards a person who is not directly in front of him or her, etc.

[0009] In order to meet the need for greater adaptability of the shape of the seating, special seating with adjustable backrests have been developed, offering the user the possibility of arranging different portions of the backrest according to a plurality of different configurations, adapting its shape to the activity he or she is performing or to the body position he or she finds most relaxing and comfortable.

[0010] Currently known adjustable backrests have, in their upper portion, at least two independent movable elements, hinged to the top of a fixed frame, the latter being integral with the supporting structure of the seating itself. An example of such a backrest is described in Italian patent no. 1417233 in which two independent movable elements allow the inclination of the upper right and upper left portions of the backrest to be adjusted separately from the fixed lower portion. Other examples of similar assemblies can be found for example in WO 2013/061259 A1 and DE 10 2008 028623 A1.

[0011] There are, however, no known examples of seating that integrate a sliding, extractable seat, of the type commonly referred to as "recliner" or "relax", with a backrest whose conformation can be changed to better suit the posture one wishes to assume.

Objects and summary of the invention

[0012] In the present patent text, the words "sliding seat" or "extractable seat" mean a seat of the type commonly implemented in reclining armchairs and sofas equipped with a "recliner" or "relax" mechanism, i.e., a seat including an upper frame that slides with respect to a fixed lower frame resting on the ground.

[0013] The object of the present invention is to combine the advantages of an extractable sliding seat, typical of sofas and armchairs equipped with a "recliner" or "relax" mechanism, with the advantages of a backrest with an adjustable conformation. Advantageously, the present invention allows both to change the arrangement of the seating, by reclining the backrest and translating the seat forward in order to assume a substantially lying position, and to change the conformation of the backrest, particularly by adjusting the inclination of the upper left portion independently of the upper right portion.

[0014] In other words, the object of the present invention is to provide an assembly of a seat and a backrest for upholstered seating, whose configuration can be modified by the user with the aim of better adapting it to the position he or she wishes to assume or even just for ornamental purposes, by changing the position and inclination of the seat and backrest, as well as the shape of the backrest itself.

[0015] A further object of the present invention is to provide a seat-backrest assembly for upholstered seating that is extremely versatile and adaptable and also simple and inexpensive to produce.

[0016] Not the least of the objects of the present invention is to provide a seat-backrest assembly for uphol-

stered seating that is functional, quick, and extremely easy to adjust for any type of user.

[0017] The achievement of these and other objects is obtained by an assembly consisting of an extractable sliding seat and an adjustable-conformation backrest, intended to form an integrated part of upholstered seating such as sofas or armchairs.

[0018] In a preferred embodiment, the seat object of the present invention includes an upper movable frame slidably connected to a lower fixed frame resting on the ground. The adjustable-conformation backrest includes a lower half-frame and an upper half-frame including at least two upper movable elements, each one rotationally connected to the lower half-frame of the backrest. The lower half-frame of the backrest is rotationally connected to the rear portion of the upper movable frame of the seat. The upper movable elements can be of various shapes and preferably, but not exclusively, have a planar conformation, suitable to be accommodated within the seating backrest. Each of these movable elements, according to the possible embodiments, includes a parallelepiped batten connected to the underlying lower half-frame by means of two articulated arms, or a suitably shaped tubular metal frame. Independently of the embodiment, the movable elements are rotationally connected to the upper portion of the lower half-frame, according to axes of rotation substantially parallel to the transverse axis of the seat. Each movable element is connected to the lower half-frame of the backrest, independently of the other movable elements, by known connecting means such as joints, hinges, pivots and the like. Movable elements can be at least partially made of flexible or deformable materials, in which case the movable elements can be made integral with the upper portion of the lower half-frame, without employing joints or other connecting means.

[0019] The movable seat frame, the lower half-frame of the backrest, and the fixed seat frame are connected to each other by an articulated kinematic mechanism that allows the forward translation of the movable seat frame with respect to the fixed frame and simultaneously causes the backward inclination of the lower half-frame of the backrest with respect to the movable seat frame. This kinematic mechanism allows the seat-backrest assembly to assume two different main configurations: a reclined position, suitable in case the user wants to assume a lying supine posture, and a sitting position, suitable in case the user simply wants to sit on the seat.

[0020] In the reclined position, the movable seat frame is translated forward and protrudes from the front edge of the underlying fixed frame, while the lower half-frame of the backrest is inclined backward, forming an angle greater than 90° with respect to the movable seat frame.

[0021] In the sitting position, on the other hand, the movable frame is retracted and does not protrude from the edge of the fixed lower frame, while the lower half-frame of the backrest is arranged in an essentially vertical plane forming an angle of about 90°, or however slightly more than a right angle, with respect to the movable seat

frame.

[0022] Differently from currently known technical solutions, in the present invention the lower portion of the backrest is rotationally connected to the upper movable frame of the sliding seat and not to the fixed supporting structure of the seat instead. This allows the user both to recline the seating to assume a lying posture and at the same time to shape the upper portion of the backrest to his or her liking by adjusting the movable elements, so the user is offered the possibility of configuring the seating in a much greater number of different conformations and positions than those made available by known state-of-the-art seating, thus increasing the comfort and adaptability of the seating.

[0023] The seat and backrest normally include an outer covering; the backrest is also complemented by a padding of soft material that covers the lower half-frame and the upper movable elements.

[0024] Advantageously, the seat can integrate an extractable footrest, placed on the front side of the seat and connected with the aforementioned movable frame through the same above-mentioned kinematic mechanism. The footrest unfolds, translating forward and raising up, simultaneously with the forward translation of the movable seat frame, when the seat-backrest assembly is arranged from the sitting to the reclined position.

Brief description of the drawings

[0025]

Fig. 1 shows a side view of an embodiment of the assembly of an extractable sliding seat (1) and an adjustable-conformation backrest (2) in the sitting position in which the seat (1) is fully retracted and the backrest (2) is arranged in a substantially vertical plane. The upholstery is shown with dotted line as it can be of various shapes and forms.

Fig. 2 shows a left side view of the assembly in Fig. 1 in the fully extracted position in which the movable seat element (1) is translated forward and the backrest (2) is reclined backward; the footrest (4) is also in the fully extracted position.

Fig. 3 shows a right side view of the assembly shown in Fig. 2.

Fig. 4 shows a detail view of the upper movable elements (22) of the backrest (2); one upper movable element (22) is shown inclined about 90° with respect to the lower half-frame (21) of the backrest (2), while a second upper movable element (22) is arranged aligned with the underlying lower half-frame (21).

Fig. 5 shows two upper movable elements (22) each including an elongated element (222) of parallelepiped shape and a pair of articulated arms (221) each composed of two half-arms connected to each other by a joint (223).

Detailed description of an embodiment of the invention

[0026] The assembly object of the present invention includes an extractable seat (1) for upholstered seating, in particular armchairs and sofas, integrated with an adjustable-conformation backrest (2). The lower portion of said backrest (2) is connected, not integrally, but by means of a kinematic mechanism (3), to the rear portion of the sliding element of said extractable seat (1); the same kinematic mechanism (3) also connects the sliding element of the seat (1) to the fixed element of the seat (1) itself.

[0027] In a preferred embodiment of the invention, the seat (1) comprises a lower fixed frame (11) and an upper movable frame (12) slidable with respect to said fixed frame (11), the latter being provided below with means for resting on the ground. The upper movable frame (12) is capable of translating with respect to the lower fixed frame (11) by passing from a fully retracted position, in which said movable frame (12) does not protrude with respect to the outline of the underlying fixed frame (11), to a fully extracted position, in which said movable frame (12) projects with respect to the front edge of said fixed frame (11). In the embodiment shown in the figures, as the upper movable frame (12) moves forward, it also rotates slightly upward, so that when the upper frame (12) is in the fully extracted position, its front portion is slightly higher than the rear portion.

[0028] The backrest (2) comprises a lower half-frame (21) and two upper movable elements (22), each of which is hinged, independently of the other, to the upper portion of the lower half-frame (21). Each of said upper movable elements (22) rotates according to an axis substantially parallel to the transverse axis of the seat (1). The latter is connected to the rear portion of the movable frame (12) of said seat (1) by means of the aforementioned kinematic mechanism (3), which causes the lower half-frame (21) to rotate backward, that is, progressively increasing the width of the angle between the seat (1) and the lower half-frame (21), as the movable frame (12) of the seat (1) is translated forward with respect to the fixed frame (11).

[0029] In practice, said kinematic mechanism (3) consists of a system of mechanical elements connected by joints and articulated connections that enable motion to be transmitted among the different parts of the mechanism, also converting the rectilinear motion of one element into a circular motion of a second element.

[0030] The kinematic mechanism (3) is integrally connected to the lower fixed frame (11) of the seat (1) and is associated with both the movable frame (12) of the seat (1) itself and the lower half-frame (21) of the backrest (2) by means of connecting means which allow the forward translation of the movable frame (12) with respect to the fixed frame (11) simultaneously causing the backward rotation of the lower half-frame (21) of the backrest (2) with respect to the movable frame (12) of the seat (1);

said rotation is carried out according to an axis substantially parallel to the transverse axis of the seat (1). Thanks to said kinematic mechanism (3), the seat-backrest assembly can be configured according to two different basic positions: a fully reclined position, suitable in case the user wants to assume a lying supine posture, and a sitting position, suitable in case the user wants to simply sit on top of the seat.

[0031] In the reclined position, the movable frame (12) of the seat (1) is translated forward and protrudes from the front edge of the underlying fixed frame (11), while the lower half-frame (21) of the backrest (2) is inclined backward, forming an angle larger than 90° with respect to said movable frame (12) of the seat (1). In the sitting position, the movable frame (12), on the other hand, is retracted and does not protrude from the edge of the underlying fixed frame (11), while the lower half-frame (21) of the backrest (2) is arranged in an essentially vertical plane forming an angle of about 90°, or however slightly more than a right angle, with respect to the movable frame (12) of the seat (1).

[0032] In the embodiment here described, each upper movable element (22) is composed of an elongated element (222) of essentially parallelepiped shape connected to the underlying lower half-frame (21) of the backrest (2) by means of a pair of articulated arms (221). Each articulated arm (221) is composed of an upper half-arm, integrally connected with a respective lateral side of the aforementioned elongated element (222), and a lower half-arm, integral with the lower half-frame (21) of the backrest (2) and connected to the upper half-arm by means of a joint (223) allowing the mutual rotation of the two half-arms around an axis substantially parallel to the transverse axis of the seat. In the embodiment shown in the figures, said elongated element (222) is a parallelepiped-shaped batten; in a possible alternative embodiment said elongated element (222) is a hollow tubular profile with a rectangular cross-section.

[0033] The joint (223) preferably includes an automatic friction mechanism which allows the mutual rotation of the two half-arms composing each articulated arm (221) only when a predetermined value of torque is exceeded; the automatic friction mechanism can then be disengaged simply by applying to the upper movable element (22) a stress sufficient to overcome this limiting torque, while in the case of stresses arising from the body resting on the upper movable element (22) such mechanism remains engaged, preventing any rotation of the upper movable element (22). As an alternative to said automatic friction means, other means of known type can be implemented to control the rotation of the articulated arms (221), either of manual or automatic or motorized type.

[0034] In the example shown in the figures, there are two upper movable elements (22) respectively connected to the side ends of the lower half-frame (21). Each of said upper movable elements (22) can rotate independently of the other movable element (22) by an angle of 180° or more; in Figure 4, a first upper movable element

(22) is arranged in a substantially vertical plane, aligned with the lower half-frame (21) of the backrest, while a second movable element (22) is arranged in a substantially horizontal plane, forming an angle of about 90° with respect to the first upper movable element (22).

[0035] In the attached figures, the two upper movable elements (22) are connected on the upper side by a band (23) of flexible, elastically deformable material that wraps both elongated elements (222) and deforms adapting itself to the different angular configurations of the two upper movable elements (22).

[0036] The backrest (2) is complemented by a padding of soft, yielding material covering the lower half-frame (21), the upper movable elements (22), and the band (23); a covering wraps this padding externally. The seat (1) is also complemented by an outer covering and, preferably but not exclusively, by a padding, the latter covering at least superiorly the movable frame (12). Finally, an armchair or sofa comprising the seat-backrest assembly object of the present invention may further comprise side armrests and one or more cushions.

[0037] In a particularly complete embodiment, the seat-backrest assembly object of the present invention further includes an extractable footrest (4) whose unfolding is controlled by the same kinematic mechanism (3) connecting the lower half-frame (21) of the backrest (2), the movable frame (12) of the seat (1) and the fixed frame (11) of the seat (1) itself. The translation of the movable frame (12) of the seat (1) from the retracted position to the extracted position also causes the footrest (4) to unfold, which translates and rotates from a rest position, in which it is arranged vertically adjacent to the front side of the seat (1), to a fully extracted position, in which it is arranged in front of the seat (1) on a nearly horizontal plane, at approximately the same height from the ground of the front portion of the seat (1) itself.

Claims

1. An assembly of an extractable sliding seat and an adjustable-conformation backrest for upholstered seats such as sofas or armchairs wherein it comprises:
 - a seat (1) comprising a lower fixed frame (11) provided with means for resting on the ground and an upper movable frame (12) slidable with respect to said fixed frame (11), said upper movable frame (12) being capable of translating with respect to said lower fixed frame (11) by passing from a fully retracted position, in which said movable frame (12) does not protrude with respect to the outline of the underlying fixed frame (11), to a fully extracted position, in which said movable frame (12) protrudes with respect to the front edge of said fixed frame (11);
 - a backrest (2) comprising a lower half-frame

(21) and at least two upper movable elements (22), each of which is rotationally connected, according to a respective axis substantially parallel to the transverse axis of the seat (1), independently of the other, to the upper portion of the lower half-frame (21), the latter being connected to the rear portion of the movable frame (12) of said seat (1) by means of a kinematic mechanism (3) which causes the lower half-frame (21) to rotate backward as the movable frame (12) of the seat (1) translates forward with respect to the fixed frame (11);

- a kinematic mechanism (3) integrally connected to the lower fixed frame (11) of said seat (1) and associated with said movable frame (12) and the lower half-frame (21) of said backrest (2) by means of connecting means which allow the forward translation of said movable frame (12) with respect to said fixed frame (11) simultaneously causing the backward rotation of said lower half-frame (21) with respect to said movable frame (12), according to an axis substantially parallel to the transverse axis of the seat (1).

2. Assembly according to the preceding claim **characterized in that** it comprises an extractable footrest (4) associated with said kinematic mechanism (3) by means of connection means which, as a result of the translation of said movable frame (12) from the retracted position to the extracted position, cause the footrest (4) to be displaced, the latter moving from a resting position in which it is placed vertically adjacent to the front side of the seat (1) to a fully extracted position in which it is placed in front of the seat (1) on a nearly horizontal plane.
3. Assembly according to one of the preceding claims **characterized in that** each of said upper movable elements (2) comprises a tubular frame.
4. Assembly according to the preceding claim **characterized in that** each tubular frame is connected to said lower half-frame (21) of the backrest (2) by a joint allowing rotation of said tubular frame about an axis substantially parallel to the transverse axis of the seat (1).
5. Assembly according to the preceding claim **characterized in that** said joint comprises an automatic friction mechanism that allows rotation of said tubular frame with respect to the lower half frame (21) only when a predetermined value of torque is exceeded.
6. Assembly according to one of the preceding claims 1 or 2 **characterized in that** each of said upper movable elements (22) comprises an elongate element (222) having a substantially parallelepiped shape

and a pair of articulated arms (221) connecting said elongate element (222) to the upper portion of said lower half-frame (21) of the backrest (2).

7. Assembly according to the preceding claim **characterized in that** each of said articulated arms (221) comprises an upper half-arm, adapted to be integrally connected with a respective side of said elongated element (222), and a lower half-arm adapted to be integrally connected with the lower half-frame (21) of said backrest (2), said half-arms being reciprocally connected by means of a joint (223) which allows mutual rotation of the two half-arms about an axis substantially parallel to the transverse axis of the seat (1).
8. Assembly according to the preceding claim **characterized in that** said joint (223) comprises an automatic friction mechanism that allows the reciprocal rotation of said half-arms of each articulated arm (221) only when a predetermined value of torque is exceeded.
9. Assembly according to one of the preceding claims **characterized in that** said upper movable elements (22) are connected by a band (23) of elastically deformable material.
10. Assembly according to one of the preceding claims **characterized in that** said lower half-frame (21) and said upper movable elements (22) of said backrest (2) are housed within a padding of soft and yielding material externally lined with a covering of flexible material, and **in that** said movable frame (12) of said seat (1) is covered at least superiorly with a padding of soft and yielding material externally lined with a covering of flexible material.

Patentansprüche

1. Baugruppe eines ausziehbaren Schiebesitzes und einer verstellbaren Rückenlehne für gepolsterte Sitze wie etwa Sofas oder Sessel, **wobei** sie folgende Elemente umfasst:
 - einen Sitz (1), der einen unteren festen Rahmen (11), der mit Mitteln zum Aufliegen auf dem Boden versehen ist, und einen oberen beweglichen Rahmen (12) umfasst, der in Bezug auf den festen Rahmen (11) verschiebbar ist, wobei der obere bewegliche Rahmen (12) in der Lage ist, sich in Bezug auf den unteren festen Rahmen (11) zu verschieben, indem er von einer vollständig eingefahrenen Position in der der bewegliche Rahmen (12) in Bezug auf den Umriss des darunter liegenden festen Rahmens (11) nicht vorsteht, in eine vollständig ausgezogene

Position übergeht, in der der bewegliche Rahmen (12) in Bezug auf die Vorderkante des festen Rahmens (11) vorsteht;

- eine Rückenlehne (2), die einen unteren Halbrahmen (21) und mindestens zwei obere bewegliche Elemente (22) umfasst, von denen jedes entsprechend einer jeweiligen Achse, die im Wesentlichen parallel zur Querachse des Sitzes (1) verläuft, unabhängig vom anderen drehbar mit dem oberen Teil des unteren Halbrahmens (21) verbunden ist, wobei letzterer mit dem hinteren Teil des beweglichen Rahmens (12) des Sitzes (1) über einen kinematischen Mechanismus (3) verbunden ist, der eine Rückwärtsdrehung des unteren Halbrahmens (21) bewirkt, wenn sich der bewegliche Rahmen (12) des Sitzes (1) in Bezug auf den festen Rahmen (11) vorwärts bewegt;

- einen kinematischen Mechanismus (3), der mit dem unteren festen Rahmen (11) des Sitzes (1) verbunden ist und dem beweglichen Rahmen (12) und dem unteren Halbrahmen (21) der Rückenlehne (2) mittels Verbindungsmitteln zugeordnet ist, und die Vorwärtsverschiebung des beweglichen Rahmens (12) in Bezug auf den festen Rahmen (11) ermöglichen und gleichzeitig die Rückwärtsdrehung des unteren Halbrahmens (21) in Bezug auf den beweglichen Rahmen (12) gemäß einer zur Querachse des Sitzes (1) im Wesentlichen parallelen Achse bewirken.

2. Baugruppe nach dem vorhergehenden Anspruch, **dadurch gekennzeichnet, dass** sie eine ausziehbare Fußstütze (4) umfasst, die mit dem kinematischen Mechanismus (3) mittels Verbindungsmitteln verbunden ist, die infolge der Verschiebung des beweglichen Rahmens (12) aus der eingefahrenen Position in die ausgezogene Position eine Verschiebung der Fußstütze (4) bewirken, wobei sich diese aus einer Ruheposition, in der sie vertikal neben der Vorderseite des Sitzes (1) angeordnet ist, in eine vollständig ausgezogene Position bewegt, in der sie vor dem Sitz (1) in einer nahezu horizontalen Ebene angeordnet ist.
3. Baugruppe nach einem der vorhergehenden Ansprüche, **dadurch gekennzeichnet, dass** jedes der oberen beweglichen Elemente (2) einen rohrförmigen Rahmen umfasst.
4. Baugruppe nach dem vorhergehenden Anspruch, **dadurch gekennzeichnet, dass** jeder rohrförmige Rahmen mit dem unteren Halbrahmen (21) der Rückenlehne (2) durch ein Gelenk verbunden ist, das die Drehung des rohrförmigen Rahmens um eine zur Querachse des Sitzes (1) im Wesentlichen parallele Achse ermöglicht.

5. Baugruppe nach dem vorhergehenden Anspruch, **dadurch gekennzeichnet, dass** das Gelenk einen automatischen Reibungsmechanismus umfasst, der eine Drehung des Rohrrahmens in Bezug auf den unteren Halbrahmen (21) nur dann zulässt, wenn ein vorbestimmter Drehmomentwert überschritten wird.
6. Baugruppe nach einem der vorhergehenden Ansprüche 1 oder 2, **dadurch gekennzeichnet, dass** jedes der oberen beweglichen Elemente (22) ein längliches Element (222) mit einer im Wesentlichen parallelepipedischen Form und ein Paar von Gelenkarmen (221) umfasst, die das längliche Element (222) mit dem oberen Teil des unteren Halbrahmens (21) der Rückenlehne (2) verbinden.
7. Baugruppe nach dem vorhergehenden Anspruch, **dadurch gekennzeichnet, dass** jeder der Gelenkarme (221) einen oberen Halbarm umfasst, der so beschaffen ist, dass er mit einer entsprechenden Seite des länglichen Elements (222) integral verbunden werden kann, und einen unteren Halbarm, der so beschaffen ist, dass er mit dem unteren Halbrahmen (21) der Rückenlehne (2) integral verbunden werden kann, wobei die Halbarme mittels eines Gelenks (223), das eine gegenseitige Drehung der beiden Halbarme um eine zur Querachse des Sitzes (1) im Wesentlichen parallele Achse ermöglicht, wechselseitig verbunden sind.
8. Baugruppe nach dem vorhergehenden Anspruch, **dadurch gekennzeichnet, dass** das Gelenk (223) einen automatischen Reibungsmechanismus umfasst, der die gegenseitige Drehung der Halbarme jedes Gelenkarms (221) nur dann zulässt, wenn ein vorbestimmter Drehmomentwert überschritten wird.
9. Baugruppe nach einem der vorhergehenden Ansprüche, **dadurch gekennzeichnet, dass** die oberen beweglichen Elemente (22) durch ein Band (23) aus elastisch verformbarem Material verbunden sind.
10. Baugruppe nach einem der vorhergehenden Ansprüche, **dadurch gekennzeichnet, dass** der untere Halbrahmen (21) und die oberen beweglichen Elemente (22) der Rückenlehne (2) in einer Polsterung aus weichem und nachgiebigem Material untergebracht sind, die außen mit einem Bezug aus flexiblem Material ausgekleidet ist, und dass der bewegliche Rahmen (12) des Sitzes (1) zumindest oben mit einer Polsterung aus weichem und nachgiebigem Material bedeckt ist, die außen mit einem Bezug aus flexiblem Material ausgekleidet ist.

Revendications

1. Un ensemble comprenant un siège coulissant extractible et un dossier à conformation réglable pour sièges rembourrés tels que canapés ou fauteuils, où il comprend :
- un siège (1) comprenant un cadre inférieur fixe (11) pourvu de moyens pour reposer sur le sol et un cadre supérieur mobile (12) coulissant par rapport audit cadre fixe (11), ledit cadre supérieur mobile (12) étant capable de translater par rapport audit cadre inférieur fixe (11) en passant d'une position entièrement rétractée, dans laquelle ledit cadre mobile (12) ne dépasse pas par rapport au contour du cadre fixe (11) sous-jacent, à une position entièrement extraite, dans laquelle ledit cadre mobile (12) dépasse par rapport au bord avant dudit cadre fixe (11) ;
 - un dossier (2) comprenant un demi-cadre inférieur (21) et au moins deux éléments supérieurs mobiles (22), chacun étant relié rotativement, selon un axe respectif sensiblement parallèle à l'axe transversal du siège (1), indépendamment de l'autre, à la partie supérieure du demi-cadre inférieur (21), ce dernier étant relié à la partie arrière du cadre mobile (12) dudit siège (1) au moyen d'un mécanisme cinématique (3) qui provoque la rotation vers l'arrière du demi-cadre inférieur (21) au fur et à mesure que le cadre mobile (12) du siège (1) translate vers l'avant par rapport au cadre fixe (11) ;
 - un mécanisme cinématique (3) relié intégralement au cadre inférieur fixe (11) dudit siège (1) et associé audit cadre mobile (12) et au demi-cadre inférieur (21) dudit dossier (2) par des moyens de connexion qui permettent la translation vers l'avant dudit cadre mobile (12) par rapport audit cadre fixe (11), provoquant simultanément la rotation vers l'arrière dudit demi-cadre inférieur (21) par rapport audit cadre mobile (12), selon un axe sensiblement parallèle à l'axe transversal du siège (1).
2. Ensemble selon la revendication précédente, **caractérisé en ce qu'il** comprend un repose-pieds extractible (4) associé audit mécanisme cinématique (3) par des moyens de connexion qui, en conséquence de la translation dudit cadre mobile (12) de la position rétractée à la position extraite, provoquent le déplacement du repose-pieds (4), ce dernier passant d'une position de repos dans laquelle il est placé verticalement adjacent au côté avant du siège (1) à une position entièrement extraite dans laquelle il est placé devant le siège (1) sur un plan presque horizontal.
3. Ensemble selon l'une des revendications précéden-

- tes, **caractérisé en ce que** chacun desdits éléments supérieurs mobiles (22) comprend un cadre tubulaire.
4. Ensemble selon la revendication précédente, **caractérisé en ce que** chaque cadre tubulaire est relié audit demi-cadre inférieur (21) du dossier (2) par une articulation permettant la rotation dudit cadre tubulaire autour d'un axe sensiblement parallèle à l'axe transversal du siège (1). 5
10
5. Ensemble selon la revendication précédente, **caractérisé en ce que** ladite articulation comprend un mécanisme de friction automatique qui permet la rotation dudit cadre tubulaire par rapport au demi-cadre inférieur (21) uniquement lorsqu'une valeur prédéterminée de couple est dépassée. 15
6. Ensemble selon l'une des revendications précédentes 1 ou 2, **caractérisé en ce que** chacun desdits éléments supérieurs mobiles (22) comprend un élément allongé (222) de forme sensiblement parallélépipédique et une paire de bras articulés (221) reliant ledit élément allongé (222) à la partie supérieure dudit demi-cadre inférieur (21) du dossier (2). 20
25
7. Ensemble selon la revendication précédente, **caractérisé en ce que** chacun desdits bras articulés (221) comprend un demi-bras supérieur, adapté à être relié intégralement avec un côté respectif dudit élément allongé (222), et un demi-bras inférieur adapté à être relié intégralement avec le demi-cadre inférieur (21) dudit dossier (2), lesdits demi-bras étant reliés réciproquement au moyen d'une articulation (223) qui permet la rotation mutuelle des deux demi-bras autour d'un axe sensiblement parallèle à l'axe transversal du siège (1). 30
35
8. Ensemble selon la revendication précédente, **caractérisé en ce que** ladite articulation (223) comprend un mécanisme de friction automatique qui permet la rotation réciproque desdits demi-bras de chaque bras articulé (221) uniquement lorsqu'une valeur prédéterminée de couple est dépassée. 40
45
9. Ensemble selon l'une des revendications précédentes, **caractérisé en ce que** lesdits éléments supérieurs mobiles (22) sont reliés par une bande (23) de matériau élastiquement déformable. 50
10. Ensemble selon l'une des revendications précédentes, **caractérisé en ce que** ledit demi-cadre inférieur (21) et lesdits éléments supérieurs mobiles (22) dudit dossier (2) sont logés à l'intérieur d'un rembourrage de matériau souple et élastique recouvert extérieurement d'un revêtement de matériau flexible, et **en ce que** ledit cadre mobile (12) dudit siège (1) est recouvert au moins sur le dessus d'un rembourrage
- de matériau souple et élastique recouvert extérieurement d'un revêtement de matériau flexible.

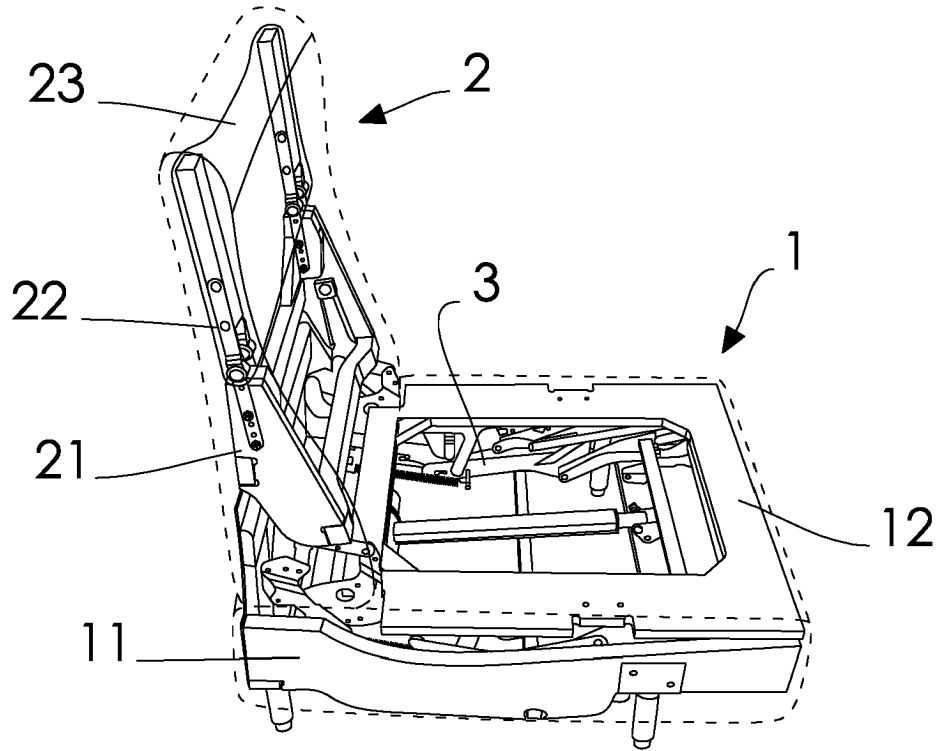

FIG. 1

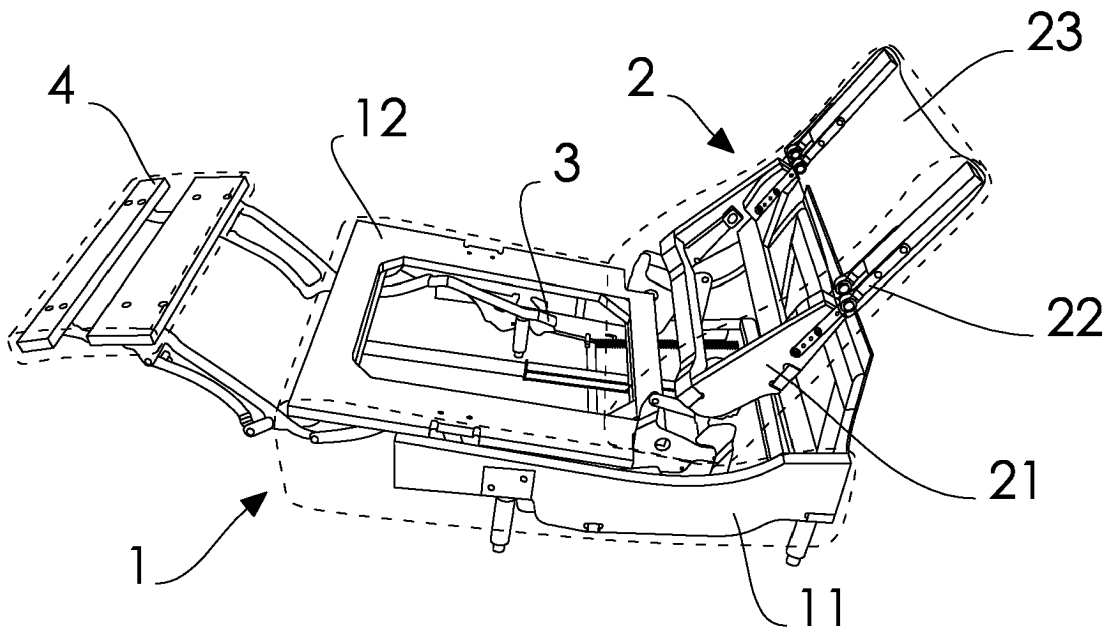
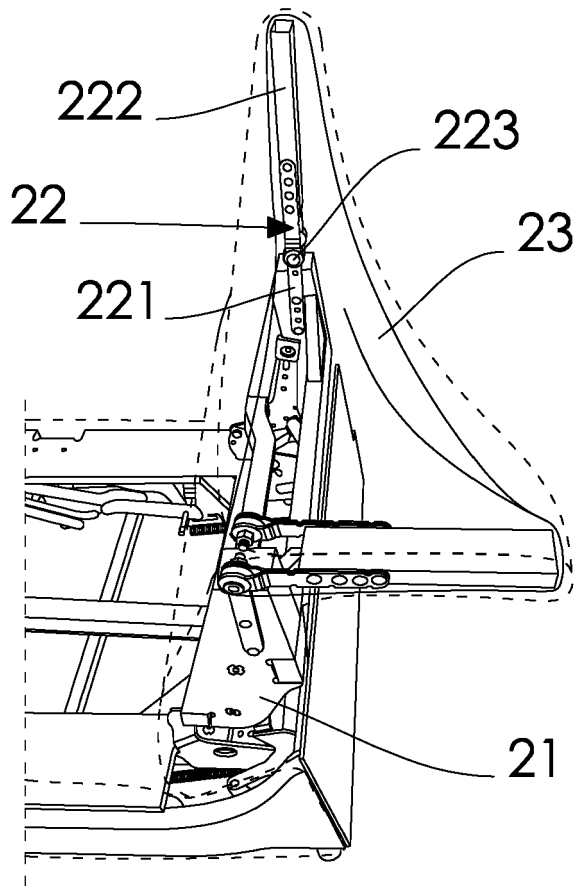
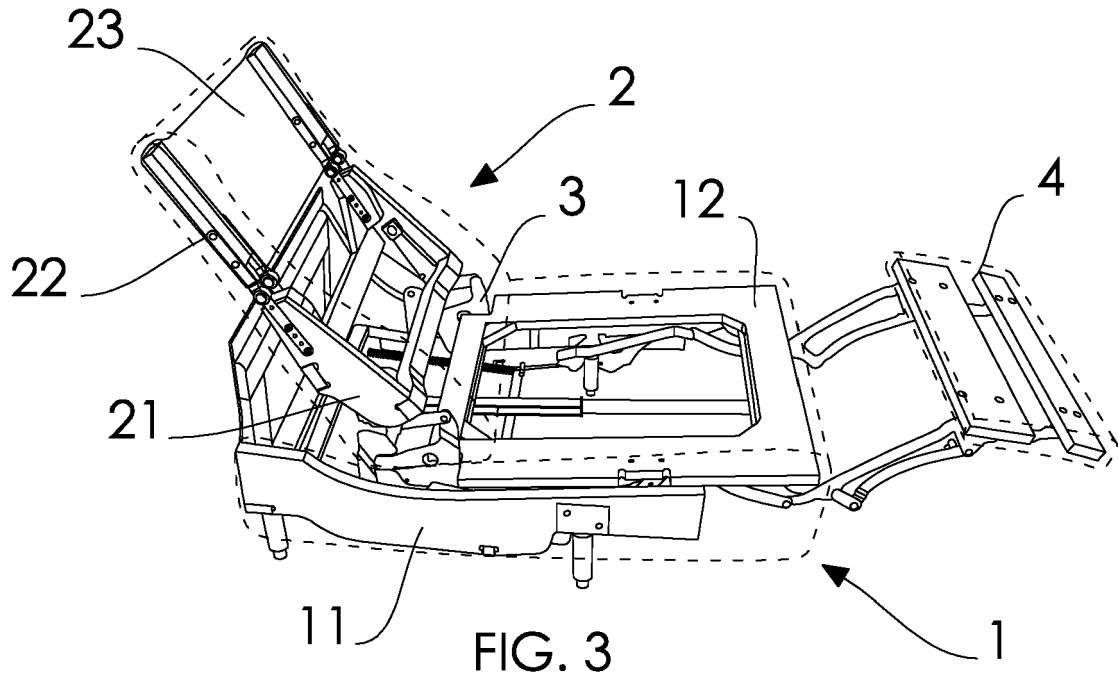

FIG. 2



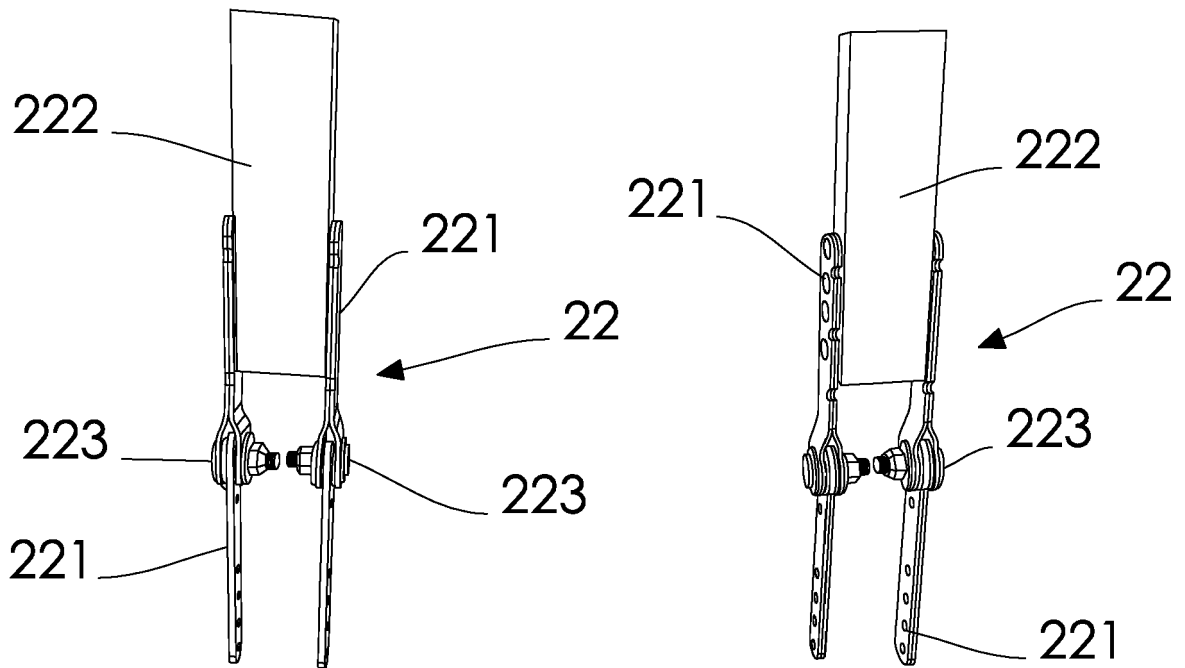

FIG. 5

REFERENCES CITED IN THE DESCRIPTION

This list of references cited by the applicant is for the reader's convenience only. It does not form part of the European patent document. Even though great care has been taken in compiling the references, errors or omissions cannot be excluded and the EPO disclaims all liability in this regard.

Patent documents cited in the description

- IT 1417233 [0010]
- WO 2013061259 A1 [0010]
- DE 102008028623 A1 [0010]