



(12) UK Patent (19) GB (11) 2 160 353 (13) B

(54) Title of Invention

Color picture tube having improved slit column pattern

(51) INT CL⁴; H01J 29/07 ✓

(21) Application No
8512993.0

(22) Date of filing
22 May 1985

(30) Priority data

(31) 614311

(32) 25 May 1984

(33) US

(43) Application published
18 Dec 1985

(45) Patent published
30 Mar 1989

(52) Domestic classification
(Edition J)
H1D DAF4 D4A4 D4A7 D4GY
D4G8 D4K4 D4K7D D4K7Y
D4K8

(56) Documents cited
GB 1310366 A
GB 1316624 A
GB 1348677 A
US 4136300 A
US 4162421 A

(58) Field of search

As for published application
2160353 A viz:
UK CL H1D
updated as appropriate

Additional fields:
INT CL⁴ H01J

(73) Proprietor(s)
RCA Corporation

(Incorporated in USA -
Delaware)

201 Washington Road
Princeton
New Jersey 08540
United States of America

(72) Inventor(s)
Walter David Masterton
Andrew Good

(74) Agent and/or
Address for Service
T I M Smith
London Patent Operation
General Electric Technical
Services Company Inc
Burdett House
15-16 Buckingham Street
London WC2N 6DU

Choyed

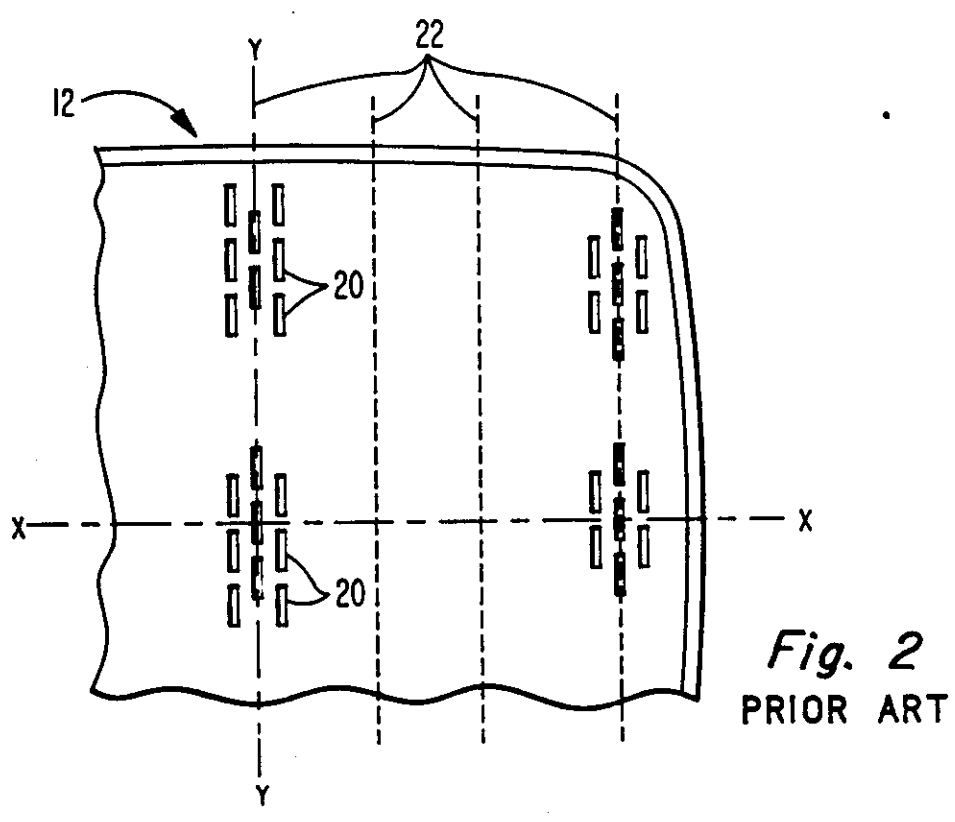
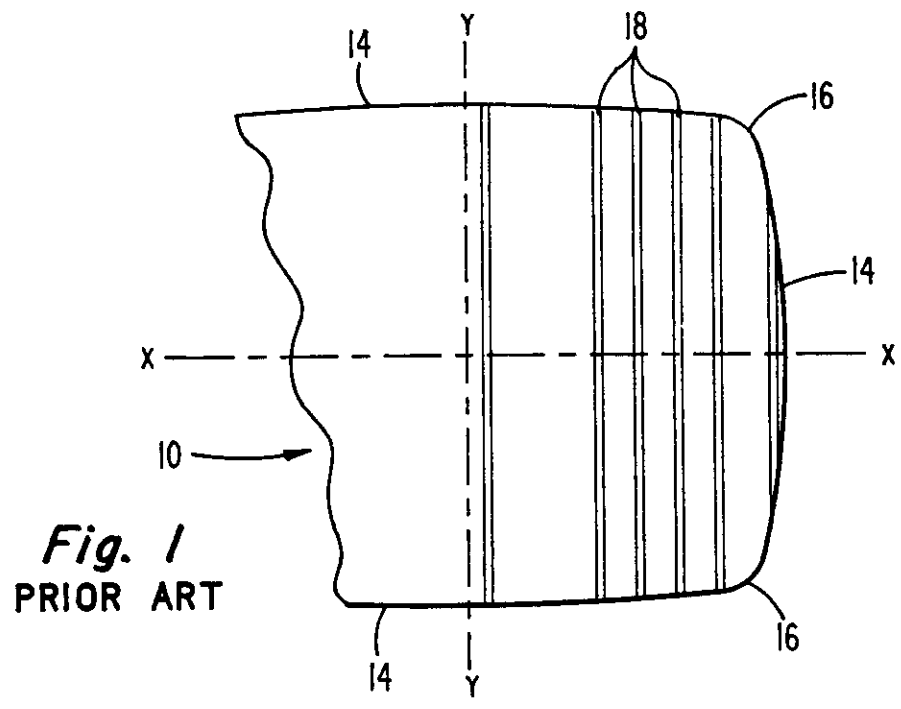

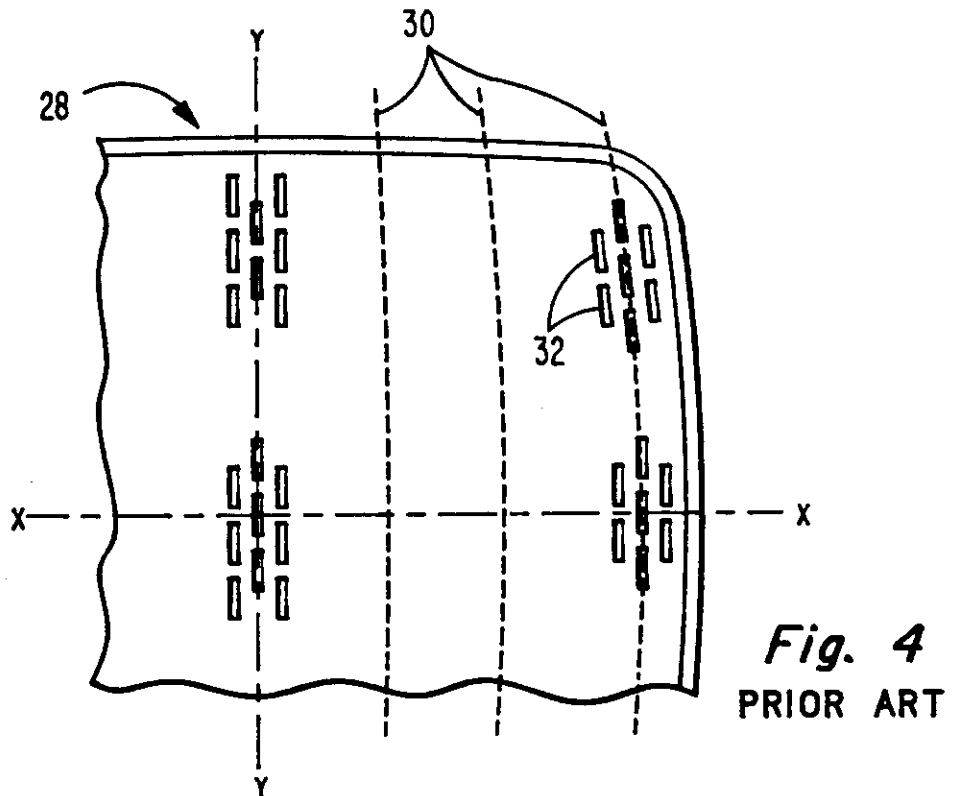
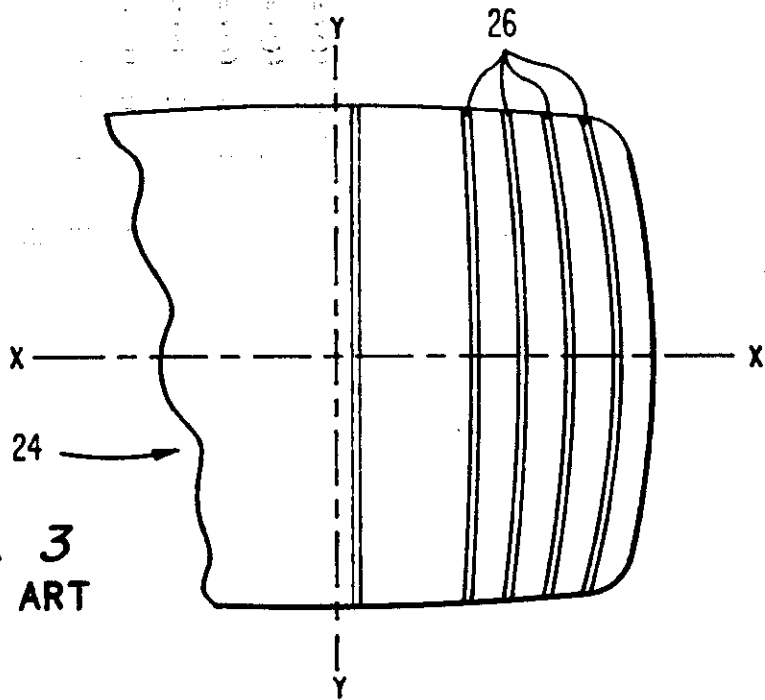

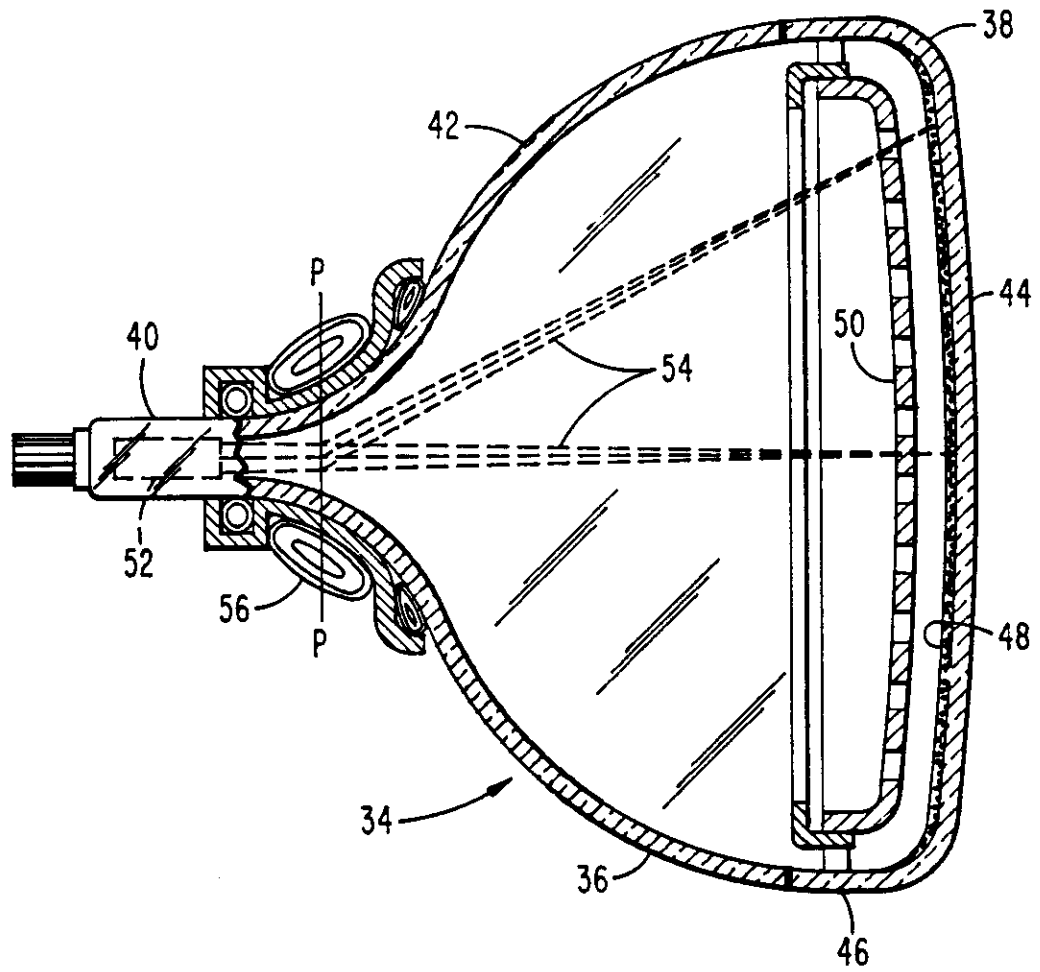

Fig. 5

4 / 4

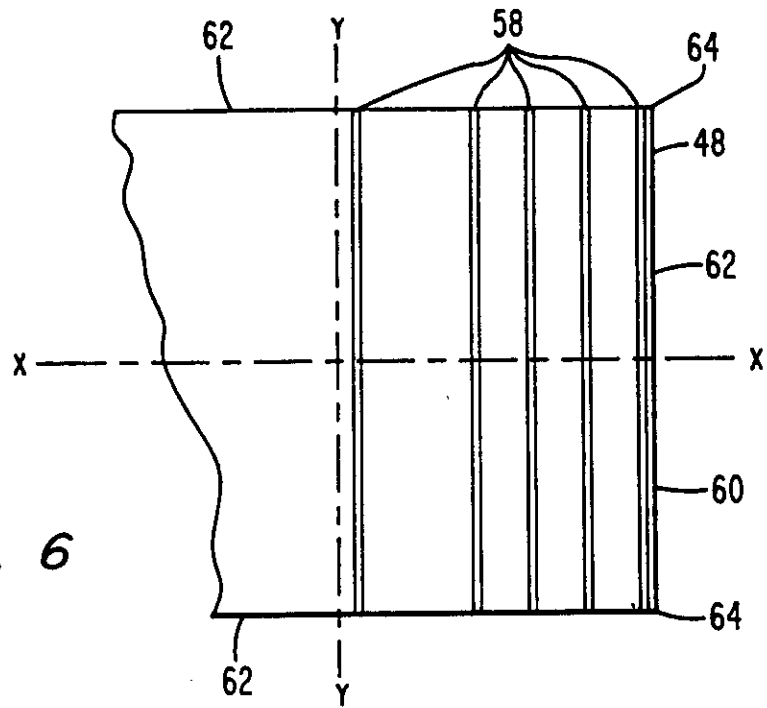

Fig. 6

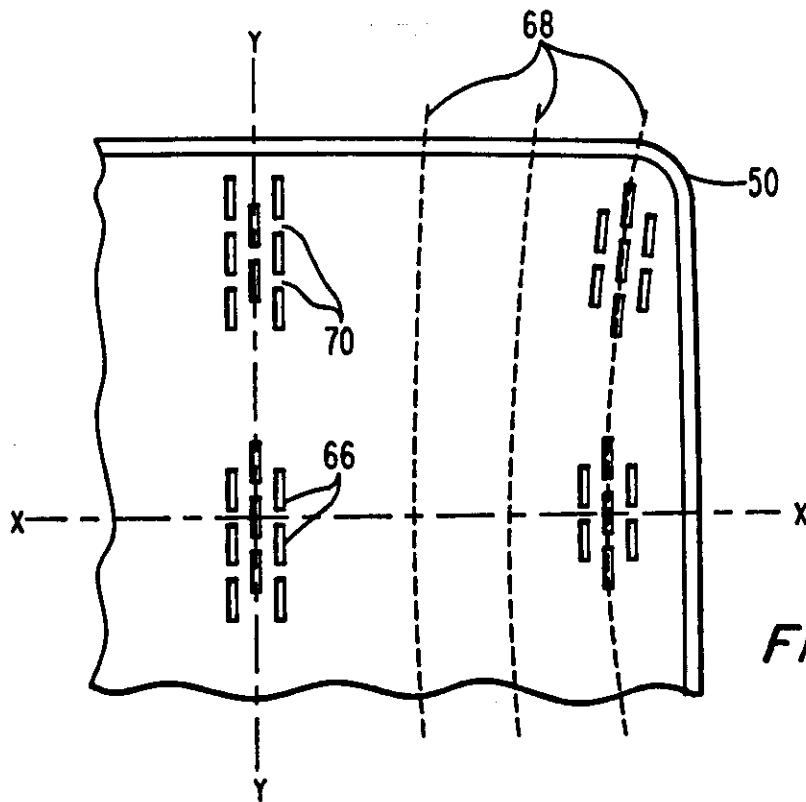

Fig. 7

COLOR PICTURE TUBE HAVING
IMPROVED SLIT COLUMN PATTERN

This invention relates to color picture tubes having cathodoluminescent line screens and slit type shadow masks therein, and particularly to an improved pattern of slit columns in the shadow masks of such tubes.

Most color picture tubes presently being manufactured are of the line screen-slit mask type. These tubes have spherically contoured faceplates with line screens of cathodoluminescent materials thereon and somewhat spherically contoured slit-apertured shadow masks adjacent to the screens. A screen 10 and a shadow mask 12 of an early type of line screen-slit mask tube are shown in FIGURES 1 and 2, respectively. In this type, the screen 10 is formed with curved sides 14, rounded corners 16 and straight vertical lines 18. The shadow mask 12 includes slit apertures 20 arranged in straight vertical columns 22. The screen is formed utilizing a photographic technique that uses a line light source for exposure and the shadow mask as a photographic master. Because of the generally spherical shape of the shadow mask 12, the off-axis slit apertures do not parallel the line light source during screening. This nonparallelism results in the formation of jagged phosphor lines on the screen. Such jagged lines are undesirable.

One technique used to overcome this problem of jagged screen lines is illustrated in FIGURES 3 and 4. A screen 24 is formed with bowed lines 26, as shown in FIGURE 3. Such bowing is concave toward the vertical axis Y-Y, with the curvature of the screen lines increasing with increasing distance from the vertical axis Y-Y. In the corresponding shadow mask 28, the aperture columns 30 are similarly bowed concavely toward the vertical axis Y-Y, as shown in FIGURE 4. Because of this bowing of the aperture columns 30, the longitudinal axes of the slit apertures 32 that are off the major axis X-X and off the minor axis Y-Y are closer to parallelism with the line light source during screening. Thus, the bowed lines 26

are smoother than are the lines of the embodiment of
FIGURE 1. Patents illustrative of this bowed screen line
and bowed aperture column concept are: U.S. Patent
3,889,145, issued to Suzuki et al. on June 10, 1975; U.S.
5 Patent 3,925,700, issued to Saito on December 9, 1975; and
U.S. Patent 3,947,718, issued to van Lent on March 30,
1976.

Recently, several color picture tube
modifications have been suggested. One of these
10 modifications is to decrease the curvatures of the
faceplate and shadow mask and to square-off the viewing
screen, so that the peripheral borders have straight sides
and the corners are substantially square. In another
modification, the curvatures of the faceplate and shadow
15 mask remain unchanged, but the peripheral border of the
screen is changed to square-off the corners of the screen.

In these modified tubes, it is desirable to
obtain substantially straight lines in all portions of the
screen, and it is particularly desirable to form straight
20 lines at the sides of the screen. In some of the above-
mentioned tube modifications, however, it is impossible to
obtain straight lines at the screen sides by utilizing
conventional construction designs and techniques. The
present invention provides a solution to this problem by
25 utilizing an improved novel pattern of slit columns in the
shadow masks of such tubes.

The present invention provides an improved color
picture tube having a line-type phosphor screen and a slit
type apertured shadow mask both having curved contours.
30 The slit apertures are arranged in columns, and the
apertures within each column are separated by webs. The
aperture columns passing through a center portion of the
mask are substantially straight, and the aperture columns
on both sides of the center portion of the mask, or at
35 least the last two columns at each side of the mask, are
convexly curved toward the center portion and increase in
curvature with distance from the center portion. The
screen lines are substantially straight and parallel.

In the accompanying drawings, of which
FIGURES 1-4 have already been described:

FIGURE 1 is a fragmentary elevational view of a prior art viewing screen.

FIGURE 2 is a fragmentary elevational view of a prior art shadow mask associated with the screen of
5 FIGURE 1.

FIGURE 3 is a fragmentary elevational view of another prior art viewing screen.

FIGURE 4 is a fragmentary elevational view of another prior art shadow mask associated with the screen
10 of FIGURE 3.

FIGURE 5 is a plan view, partly in axial section, of a shadow mask color picture tube embodying the present invention.

FIGURE 6 is a fragmentary elevational view of
15 the viewing screen of the tube of FIGURE 5, showing an enlargement of some of the phosphor lines of the screen.

FIGURE 7 is a fragmentary elevational view of the shadow mask of the tube of FIGURE 5, showing an enlargement of some of the apertures in the mask.

20 FIGURE 5 is a plan view of a rectangular color picture tube 34 having a glass envelope 36 comprising a rectangular faceplate panel 38 and a tubular neck 40 connected by a rectangular funnel 42. The panel 38 comprises a viewing faceplate 44 and peripheral sidewall
25 46, the distal edge of which is sealed to the funnel 42. A three-color phosphor screen 48 is located on the inner surface of the faceplate 44. The screen 48 is a line screen with the phosphor lines extending substantially perpendicular to the high frequency raster line scan of
30 the tube (i.e., normal to the plane of FIGURE 5). Within the tube is a multi-apertured color selection electrode or shadow mask 50, both it and the screen having a curved contour. The mask 50 is removably mounted, by conventional means, in predetermined spaced relation
35 to the screen 48. An inline electron gun 52, shown schematically by dotted lines in FIGURE 5, is centrally mounted within the neck 40 to

generate and direct three electron beams 54 along coplanar convergent paths through the mask 50 to the screen 48.

5 The tube of FIGURE 5 is designed to be used with an external magnetic deflection yoke, such as the yoke 56 schematically shown surrounding the neck 40 and funnel 42 in the neighborhood of their junction. When activated, the yoke 56 subjects the three beams 54 to magnetic fields which cause the beams to scan horizontally and vertically in a rectangular raster over the screen 48. The initial
10 plane of deflection (at zero deflection) is shown by the line P-P in FIGURE 5 at about the middle of the yoke 56. Because of fringe fields, the zone of deflection of the tube extends axially, from the yoke 56 into the region of the gun 52. For simplicity, the actual curvature of the
15 deflected beam paths in the deflection zone is not shown in FIGURE 5.

The screen 48 of the tube 34 comprises an array of straight parallel vertical phosphor lines 58, only selected ones of which are shown in FIGURE 6. The
20 phosphor lines 58 are grouped in triads of red-, green-, and blue-emitting phosphors. The phosphor lines of each triad and the triads themselves may be separated from each other by areas of light-absorbing materials. The peripheral border 60 of the screen 48 has straight sides
25 62 and square corners 64, and is substantially rectangular.

The shadow mask 50 of the tube 34 is shown in FIGURE 7. The mask 50 includes an array of elongated slot or slit-shaped apertures 66 which
30 transmit the three electron beams 54 from the gun 52 to the screen 48. The apertures 66 are arranged in columns 68 and are vertically separated from each other by bridges or web portions 70 of the mask 50. The apertures in each column 68 are vertically
35 staggered with respect to the apertures in adjacent columns. The aperture columns 68 in a center portion of the mask 50 are straight. The aperture columns 68 on both sides of the center portion of the mask are convexly curved toward the center portion. The curvature of these off-center columns

increases with increasing distance from the center portion of the mask 50.

Given the screen surface contour and the definition of the last line desired at the screen sides, the position and shape of the last column of apertures on the formed shadow masks will be determined by the contour of the shadow mask itself and its relative position to the screen. These, in turn, are a function of the separation of adjacent aperture columns chosen on the basis of screen resolution requirements, and the relative spacing of the red, green and blue electron beam spots corresponding to a particular mask aperture. The latter is, in turn, a function of the gradient in the particular deflection field used. In addition, the effects of the mask forming operation on the shape and position of the aperture columns must be taken into account when specifying the aperture columns for the unformed aperture mask.

The technique utilized to determine the position and shape of the aperture columns desired in an unformed flat mask is as follows. First, the number of x, y positions on the screen corresponding to points on the desired last line is specified. Next, the appropriate center of deflection for the system is specified. Then, the intercepts with the formed mask surface are calculated for lines from the deflection center to the specified screen points. The x, y positions thus computed for the points on the shadow mask are then modified by the subtraction of the x, y changes expected during the mask forming operation. This results in a set of x, y positions which, when connected smoothly by a spline or other mathematical smoothing means, define a curve for the desired last line of apertures in the unformed mask. Such a curve, for an embodiment of the present invention, is inwardly convex. Because of this convex curvature, the aperture column-to-column spacing, also called the a-spacing, generally increases with increasing distance from the major axis, X-X.

Example

5 Tables I, II and III present construction data
for a novel shadow mask for use in an improved color
picture tube. All of the included data is for a flat mask
before contouring. Therefore, resultant values in a
formed mask will vary to some extent depending on the many
possible variables occurring during forming. Each of the
tables represents information for one quadrant of a mask.
The left columns are distances along the Y-axis from the
10 X-axis. The bottom rows are distances along the X-axis
from the Y-axis. The top rows are Y distances at the ends
of the aperture columns. The right columns represent X
distances for the last aperture column. Table I presents
the aperture slit widths throughout the quadrant. Table
15 II presents the vertical tie bar or web dimensions between
adjacent slit apertures within an aperture column. Table
III presents the horizontal spacing (a-spacing) between
the centerlines of adjacent aperture columns. It can be
seen in Table III that the aperture columns are convexly
20 curved inwardly and that the curvature of the columns
increases with increasing distance from the minor axis.

TABLE I

SLIT WIDTH IN MILS

	7.329	7.327	7.322	7.314	7.302	7.287	7.269	7.247	7.222	7.194	7.174
@ Y=	6.73	6.73	6.76	6.81	6.89	7.00	7.11	7.21	7.38	7.66	7.64 (@X=9.642)
7.0	6.74	6.74	6.77	6.81	6.90	7.02	7.12	7.22	7.44	7.65	7.32 (@X=9.638)
6.0	6.75	6.76	6.79	6.84	6.91	7.00	7.11	7.24	7.43	7.53	7.33 (@X=9.603)
5.0	6.78	6.79	6.81	6.86	6.92	7.01	7.11	7.24	7.40	7.53	7.52 (@X=9.577)
4.0	6.85	6.85	6.86	6.90	6.96	7.04	7.13	7.25	7.40	7.53	7.48 (@X=9.559)
3.0	6.92	6.92	6.93	6.96	7.00	7.06	7.15	7.25	7.40	7.51	7.46 (@X=9.547)
2.0	6.99	6.99	7.00	7.01	7.04	7.09	7.16	7.26	7.39	7.50	7.50 (@X=9.540)
1.0	7.06	7.05	7.04	7.04	7.06	7.10	7.17	7.27	7.40	7.52	7.53 (@X=9.536)
0.0	7.11	7.07	7.05	7.05	7.07	7.11	7.17	7.27	7.40	7.54	7.54 (@X=9.535)
	0.0	1.0	2.0	3.0	4.0	5.0	6.0	7.0	7.0	7.0	9.0

X inches

8
7
6
5
4

TABLE II

TIE BAR IN MILS

@ Y=	7.329	7.327	7.322	7.314	7.302	7.287	7.269	7.247	7.222	7.194	7.174
	5.66	5.67	5.69	5.72	5.75	5.80	5.85	5.91	5.98	6.04	6.09 (@X=9.642)
7.0	5.63	5.64	5.66	5.69	5.73	5.78	5.83	5.90	5.96	6.03	6.08 (@X=9.638)
6.0	5.54	5.55	5.57	5.61	5.65	5.71	5.77	5.83	5.91	5.98	6.03 (@X=9.603)
5.0	5.45	5.46	5.49	5.53	5.58	5.64	5.71	5.78	5.85	5.93	5.98 (@X=9.577)
4.0	5.36	5.37	5.41	5.45	5.51	5.58	5.65	5.73	5.81	5.89	5.94 (@X=9.559)
3.0	5.27	5.29	5.33	5.38	5.45	5.53	5.61	5.69	5.77	5.86	5.91 (@X=9.547)
2.0	5.18	5.20	5.26	5.33	5.41	5.49	5.57	5.66	5.75	5.83	5.88 (@X=9.540)
1.0	5.09	5.13	5.20	5.29	5.37	5.46	5.55	5.64	5.73	5.82	5.87 (@X=9.536)
0.0	5.00	5.09	5.18	5.27	5.36	5.45	5.54	5.63	5.72	5.82	5.86 (@X=9.535)
	0.0	1.0	2.0	3.0	4.0	5.0	6.0	7.0	7.0	7.0	9.0

X inches

50
FO
-T
X

TABLE III

HORIZONTAL "A" IN MILS

	@ Y=	7.329	7.327	7.322	7.314	7.302	7.287	7.269	7.247	7.222	7.194	7.174
		30.00	30.07	30.29	30.66	31.18	31.85	32.68	33.64	34.77	36.06	37.01 (@X=9.642)
	7.0	30.00	30.07	30.29	30.65	31.16	31.81	32.64	33.59	34.71	35.99	36.88 (@X=9.638)
	6.0	29.99	30.07	30.27	30.62	31.10	31.72	32.50	33.39	34.45	35.65	36.44 (@X=9.603)
	5.0	30.00	30.06	30.26	30.59	31.05	31.65	32.40	33.25	34.25	35.40	36.15 (@X=9.577)
	4.0	30.00	30.06	30.25	30.58	31.02	31.60	32.32	33.15	34.12	35.22	35.90 (@X=9.559)
	3.0	30.00	30.06	30.25	30.57	31.00	31.57	32.27	33.08	34.03	35.11	35.77 (@X=9.547)
	2.0	30.00	30.06	30.25	30.56	30.99	31.55	32.25	33.04	33.98	35.04	35.69 (@X=9.540)
	1.0	30.00	30.06	30.24	30.55	30.98	31.53	32.23	33.02	33.95	35.00	35.64 (@X=9.536)
	0.0	30.00	30.06	30.24	30.55	30.98	31.53	32.22	33.01	33.94	34.98	35.63 (@X=9.535)

X inches

X inches

9.0

7.0

7.0

6.0

5.0

4.0

3.0

2.0

1.0

0.0

The flat mask, constructed in accordance with the preceding tables, is contoured to have an approximate major axis radius of 32.5 inches (82.6cm) and an approximate minor axis radius of 42.6 inches (108.2cm).

5 The contoured mask is used with a tube having a 26 inch (66.04 cm) diagonal viewing screen, and which has a faceplate outside radius of approximately 42.4 inches (107.7cm) and a faceplate inside radius of approximately 40.7 inches (103.4cm).

10 Table IV provides a comparison of the last aperture columns of the novel shadow mask as defined in the preceding tables with a conventional slit apertured shadow mask for use in a tube having a 25 inch (62.5 cm) diagonal viewing screen.

15 TABLE IV

	Conventional Mask			Novel Mask	
	Y (Inches)	X (Inches)	a-spacing (Mils)	X (Inches)	a-spacing Mils
20	0	9.645	39.52	9.535	35.63
	1.0	9.650	39.61	9.536	35.64
	2.0	9.652	39.64	9.540	35.69
	3.0	9.645	39.52	9.547	35.77
	4.0	9.628	39.32	9.559	35.90
25	5.0	9.604	39.03	9.577	36.15
	6.0	9.562	38.53	9.603	36.44
	7.0	8.979	36.89	9.638	36.88

As can be seen from the second column in Table IV, the last aperture column of the conventional mask starts at 9.645 inches at the major axis (Y=0) and gradually curves inwardly as distance from the major axis increases to equal 8.979 inches at Y=7 inches. Such curvature appears as an outwardly bowing of the aperture columns at the sides of the mask. In the novel mask, however, the last aperture column begins at 9.535 inches on the major axis and gradually increases in distance from the Y-axis with increasing distance from the major axis to equal 9.638 at Y=7 inches. Such curvature

appears as an inward bowing of the aperture columns at the sides of the novel mask.

5 The a-spacing variation in the conventional mas-
between the last two adjacent aperture columns at the
sides of the mask start at 39.52 mils at the major axis
and gradually converge to a spacing of 36.89 mils at the
Y=7 inches location. The a-spacing of the novel mask
begins at an a-spacing of 35.63 mils on the major axis and
increases with increasing distance from the major axis to
10 36.88 mils at Y=7 inches.

CLAIMS:

1. A color picture tube having a line-type phosphor screen and a slit-type apertured mask both having curved contours, the lines of said screen being substantially straight and substantially parallel to one another, and the apertures in said mask being arranged in columns with webs between the apertures in each column, the columns passing through a center portion of said mask being substantially straight, and the columns on both sides of said center portion being convexly curved toward said center portion and increasing in curvature in respect of successive columns going outwards from said center portion.

2. A tube as defined in Claim 1, wherein the center-to-center spacing between the last two aperture columns at a side of said mask increases with increasing distance from a central axis of said mask.

3. A color picture tube having a line-type phosphor screen and a slit-type apertured mask both having curved contours, the lines of said screen being substantially straight and substantially parallel to one another, said mask having a major axis and a minor axis, the apertures in said mask being arranged in columns, and the apertures within each column being separated by webs, wherein the columns passing through a center portion of said mask are substantially straight and substantially parallel to the minor axis, and the columns in the portions of the mask adjacent its sides are curved, being closer to the minor axis where they cross the major axis than they are at their ends.

4. A color picture tube having a line-type phosphor screen and a slit-type apertured mask both having curved contours, the lines of said screen being substantially straight and substantially parallel to one another, said mask having a major axis and a minor axis, the apertures in said mask being arranged in columns, with the columns passing through a center portion of the mask being substantially straight and with the apertures within each column being separated by webs, wherein the centerline-to-centerline spacing between the last two adjacent columns at a side of the mask is less where the columns cross the major axis than at their ends, these columns being convexly curved towards the center of the mask.

5. A color picture tube having a line screen and apertured mask substantially as hereinbefore described with reference to FIGURES 6 and 7 of the accompanying drawings.

REGISTER ENTRY FOR GB2160353

Form 1 Application No GB8512993.0 filing date 22.05.1985

Priority claimed:

25.05.1984 in United States of America - doc: 614311

Title COLOR PICTURE TUBE HAVING IMPROVED SLIT COLUMN PATTERN

Applicant/Proprietor

RCA CORPORATION, Incorporated in USA - Delaware, 201 Washington Road,
Princeton, New Jersey 08540, United States of America

[ADP No. 00697417003]

Inventors

WALTER DAVID MASTERTON, 834 Blue Grass Road, Lancaster, Pennsylvania,
United States of America

[ADP No. 00260547001]

ANDREW GOOD, 7 Keeler Avenue, Reamstown, Pennsylvania, United States of
America

[ADP No. 04209102001]

Classified to

H1D

H01J

Address for Service

T I M SMITH, GENERAL ELECTRIC TECHNICAL SERVICES COMPANY INC, London
Patent Operation, Burdett House, 15-16 Buckingham Street, LONDON, WC2N
6DU, United Kingdom

[ADP No. 00002279003]

Publication No GB2160353 dated 18.12.1985

Examination requested 22.05.1986

Patent Granted with effect from 30.03.1989 (Section 25(1)) with title COLOR
PICTURE TUBE HAVING IMPROVED SLIT COLUMN PATTERN

31.05.1989 RCA LICENSING CORPORATION, Incorporated in USA - Delaware, Two
Independence Way, Princetown, New Jersey 08540, United States of
America [ADP No. 04179081001]
registered as Applicant/Proprietor in place of
RCA CORPORATION, Incorporated in USA - Delaware, 201 Washington
Road, Princeton, New Jersey 08540, United States of America
[ADP No. 00697417003]
by virtue of deed of assignment dated 08.12.1987. Certified copy
filed on GB2198311

Entry Type 8.4 Staff ID. WE1 Auth ID. F21

28.10.1991 Application under Section 32 filed on 21.10.91.

Entry Type 10.1 Staff ID. MM Auth ID. EO

- 31.10.1991 Notification of change of Applicant/Proprietor name of
 RCA LICENSING CORPORATION, Incorporated in USA - Delaware, Two
 Independence Way, Princetown, New Jersey 08540, United States of
 America [ADP No. 04179081001]
 to
 RCA THOMSON LICENSING CORPORATION, Incorporated in USA - Delaware,
~~2 Independence way, Princeton, New Jersey 08540, United States of~~
 America [ADP No. 05964408001] *prev*
 dated 30.06.1991. Official evidence filed on GB2215154 *proprietor*
 Entry Type 7.2 Staff ID. GO Auth ID. EO
- 01.11.1991 Notification of change of Address For Service name and address of
 T I M SMITH, GENERAL ELECTRIC TECHNICAL SERVICES COMPANY INC,
 London Patent Operation, Burdett House, 15-16 Buckingham Street,
 LONDON, WC2N 6DU, United Kingdom [ADP No. 00002279003]
 to
 GENERAL ELECTRIC TECHNICAL SERVICES COMPANY INC, Burdett House,
 15-16 Buckingham Street, LONDON, WC2N 6DU, United Kingdom
 [ADP No. 00007849001]
 dated 25.10.1991. Official evidence filed on GB2215154
 Entry Type 7.1 Staff ID. MM Auth ID. EO
- 15.06.1992 Notification of change of Address For Service address of
 GENERAL ELECTRIC TECHNICAL SERVICES COMPANY INC, Burdett House,
 15-16 Buckingham Street, LONDON, WC2N 6DU, United Kingdom
 [ADP No. 00007849001]
 to
 GENERAL ELECTRIC TECHNICAL SERVICES COMPANY INC, Essex House, 12-13
 Essex Street, LONDON, WC2R 3AA, United Kingdom
 [ADP No. 00007849002]
 dated 14.04.1992. Official evidence filed on GB2215154
 Entry Type 7.3 Staff ID. GO Auth ID. F20

**** END OF REGISTER ENTRY ****

OA80-01
FG

OPTICS - PATENTS

17/02/94 11:06:17

PAGE: 1

RENEWAL DETAILS

PUBLICATION NUMBER

GB2160353

PROPRIETOR(S)

RCA Thomson Licensing Corporation, Incorporated in USA - Delaware,
2 Independence Way, Princeton, New Jersey 08540, United States of
America

DATE FILED

22.05.1985

DATE GRANTED

30.03.1989

DATE NEXT RENEWAL DUE

22.05.1994

DATE NOT IN FORCE

DATE OF LAST RENEWAL

20.04.1993

YEAR OF LAST RENEWAL

09

STATUS

PATENT IN FORCE