



(51) International Patent Classification:

E21B 19/02 (2006.01) *B66D 1/36* (2006.01)
B66C 1/00 (2006.01) *B66D 1/64* (2006.01)
B66D 1/00 (2006.01)

(21) International Application Number:

PCT/NO2014/050113

(22) International Filing Date:

25 June 2014 (25.06.2014)

(25) Filing Language:

English

(26) Publication Language:

English

(30) Priority Data:

61/839,194 25 June 2013 (25.06.2013) US

(71) Applicant: **NATIONAL OILWELL VARCO NORWAY AS** [NO/NO]; Postboks 401 Lundsiden, N-4604 Kristiansand S (NO).

(72) Inventors: **ERIKSSON, Hans, Anders**; Heldalslia 18, N-4790 Lillesand (NO). **BORØY, Yngvar**; Ausvigheia 27, N-4640 Søgne (NO). **ØYE, Oddbjørn**; Bordalen 17B, N-4639 Kristiansand (NO). **BERGSTØL, Geir, Odd**;

Kongsgård Alle 1, N-4631 Kristiansand (NO). **TRYDAL, Stig, Vidar, Johansen**; Juviga 21, N-4640 Søgne (NO).

(74) Agent: **HÅMSØ PATENTBYRÅ ANS**; P.O. Box 171, N-4302 Sandnes (NO).

(81) Designated States (unless otherwise indicated, for every kind of national protection available): AE, AG, AL, AM, AO, AT, AU, AZ, BA, BB, BG, BH, BN, BR, BW, BY, BZ, CA, CH, CL, CN, CO, CR, CU, CZ, DE, DK, DM, DO, DZ, EC, EE, EG, ES, FI, GB, GD, GE, GH, GM, GT, HN, HR, HU, ID, IL, IN, IR, IS, JP, KE, KG, KN, KP, KR, KZ, LA, LC, LK, LR, LS, LT, LU, LY, MA, MD, ME, MG, MK, MN, MW, MX, MY, MZ, NA, NG, NI, NO, NZ, OM, PA, PE, PG, PH, PL, PT, QA, RO, RS, RU, RW, SA, SC, SD, SE, SG, SK, SL, SM, ST, SV, SY, TH, TJ, TM, TN, TR, TT, TZ, UA, UG, US, UZ, VC, VN, ZA, ZM, ZW.

(84) Designated States (unless otherwise indicated, for every kind of regional protection available): ARIPO (BW, GH, GM, KE, LR, LS, MW, MZ, NA, RW, SD, SL, SZ, TZ, UG, ZM, ZW), Eurasian (AM, AZ, BY, KG, KZ, RU, TJ, TM), European (AL, AT, BE, BG, CH, CY, CZ, DE, DK,

[Continued on next page]

(54) Title: SYSTEM FOR HOISTING A LOAD ON AN OFFSHORE RIG

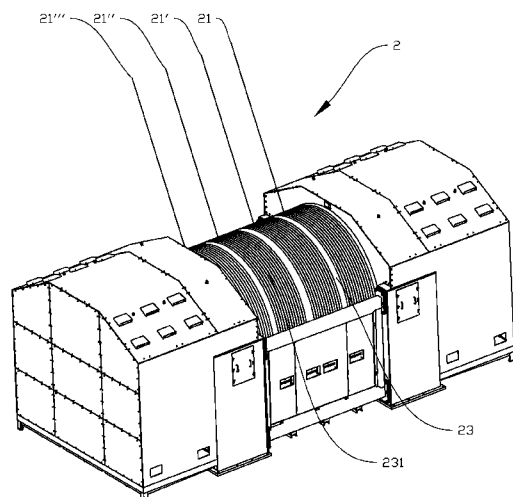

Fig. 1

(57) Abstract: There is described a system (1) for hoisting a load (7) on an offshore rig, the system (1) comprising - a winch (2) having a winch drum (23); - drive means (3) for operating said winch (2); - one or more sheaves (51a, 53a), - an elongated hoisting member (21, 21', 21'', 21'''), such as a wire rope, adapted to run over said one or more sheaves (51a, 53a) and to connect said winch (2) to a load (7), wherein said winch drum (23), in a first position of use (A), is adapted to accommodate a single layer of said elongated hoisting member (21, 21', 21'', 21''').



EE, ES, FI, FR, GB, GR, HR, HU, IE, IS, IT, LT, LU, **Published:**
LV, MC, MK, MT, NL, NO, PL, PT, RO, RS, SE, SI, SK, — *with international search report (Art. 21(3))*
SM, TR), OAPI (BF, BJ, CF, CG, CI, CM, GA, GN, GQ,
GW, KM, ML, MR, NE, SN, TD, TG).

SYSTEM FOR HOISTING A LOAD ON AN OFFSHORE RIG

The present application claims priority from provisional patent application US 61/839,194 which is incorporated by reference to the present application.

- 5 The invention relates to a system for hoisting a load on an offshore rig, the system comprising a winch having a winch drum, drive means for operating said winch, one or more sheaves, an elongated hoisting member, such as a wire rope, adapted to run over said one or more sheaves and to connect said winch to a load.

Hoisting of heavy loads on drilling rigs has traditionally been done by means of a
10 winch accommodating multiple layers of wire rope. The wire rope is connected to a load through a draw-works including many small sheaves over which the wire runs and is repeatedly bent. During lifting and lowering, and particularly in heave compensation, the wire rope undergoes numerous bending cycles under load, and is therefore subject to considerable wear. Depending on the number of sheaves in the draw-works,
15 i.e. the mechanical advantage, the wire rope on the winch side, the so-called fast line, travels a longer distance than the load, thus requiring multiple layers of wire rope on the winch. Overlying layers of wire rope act with great forces on underlying layers on the winch drum, thus further increasing the wear of the wire rope. Inertia loss in the great number of sheaves in the draw-works also leads to a rather slow acceleration of
20 the load, thus slowing down the operation time. The typical lifetime of a wire rope used together with a multi-layer winch in heave compensation mode on a drilling rig is in the order of two weeks, leading to frequent stops of operation to perform a traditional cut-and-slip to replenish the wire rope.

Prior art hoisting systems on offshore rigs typically use only one wire connected to a
25 winch in one end, running to the top of a derrick through a crown block and down to a travelling block, to which the load is connected, and further to a deadline anchor, typically anchored to the rig floor or to the derrick. When using only one wire, it is of the utmost importance that the wire does not break, as this could cause severe damage to

rig and personnel. The fear of wire fatigue also contributes to the frequent replenishment of wire rope. Wires used for heavy lifting operations are very expensive.

It is thus an object of the invention to increase the lifetime of wire ropes used in offshore hoisting operations, and in particular for lifting drill pipes and stands in active heave compensation and for lifting complete drill strings. Other objects of the invention are to improve safety in offshore lifting operations as well as reducing operation times.

The invention has for its general object to remedy or to reduce at least one of the drawbacks of the prior art, or at least to provide a useful alternative to prior art.

The object is achieved through features which are specified in the description below and in the claims that follow.

The invention is defined by the independent patent claims. The dependent claims define advantageous embodiments of the invention.

More specifically the invention relates to a system for hoisting a load on an offshore rig, the system comprising

- a winch having a winch drum;
- drive means for operating said winch;
- one or more sheaves,
- an elongated hoisting member, such as a wire, adapted to run over said one or more sheaves and to connect said winch to a load, wherein said winch drum, in a first position of use, is adapted to accommodate a single layer of said elongated hoisting member.

In the following the elongated hoisting member will be exemplified by a wire rope.

The use of a single-layer winch offers several advantages over conventional multi-layer winches that have traditionally been used on offshore rigs. In a multi-layer winch, underlying layers of wire rope will typically be exposed to great wear and tear from overlying layers, hence reducing the lifetime of the wire. Multi-layer winches have been required when using traditional draw-works on drilling rigs, with relatively small winches and a great number of sheaves to achieve the necessary mechanical advantage. The wire rope undergoes numerous bending cycles around the sheaves. The fast line from the winch travels many times the distance of the load, connected to the travelling block. Hence, multiple layers of wire are required to accommodate a wire of sufficient length. A system hoisting a load on a drilling rig including a single

layer winch preferably should include a limited number of sheaves between the load and the winch. In preferred embodiments the sheaves in the crown block and travelling block may be arranged so as to give a transmission in the range of 2:1 to 4:1. In one embodiment the winch may even be a so-called direct line winch with no transmission/gearing in the sheaves.

In one embodiment the system may comprise two or more parallel wires connecting said winch to said load. The use of multiple parallel wires may significantly improve safety, as the system may operate in redundancy with respect to the number of required wires. In case of wire failure, and even if a wire breaks, the system may still be operating within its capacity. The parallel wires may be connected to the same winch drum. The number of parallel wires is not limited, but in exemplary embodiments the system may comprise two to six parallel wires.

In one embodiment said winch drum may be provided with a helical groove for accommodating said single layer of wire rope. The helical groove will prevent the wire on the winch from wear, as it prevents cross-contact between neighbouring wire layers, thus further increasing the lifetime of the wire rope. The winch drum may be provided with one groove for each wire rope, where several parallel wire ropes are used.

In one embodiment the system may further comprise motion compensation means, such as heave compensation means. This may be preferable if the system is provided on an offshore drilling rig where there is a need to compensate for undesired movement of the load due to wind and waves. In one embodiment, the winch itself may be provided with heave compensation means. Traditionally, repeated lifting and lowering of a load, such as a drill string section during tripping, has entailed numerous wire rope bending cycles around the multiple sheaves in draw-works, leading to an extensive wear and reduced lifetime of the wire rope. Heave compensation by means of a system according to the present invention will not wear the wire rope to the same extent due to the fact that the wire rope only undergoes a few, if any, bending cycles during lifting and lowering. It is also preferable to use relatively large sheaves, implying that a large part of the wire stays on the sheave upon lifting and lowering, hence not leaving the sheave, and thus not undergoing a bending cycle.

In one embodiment a ratio between the diameter of said winch drum in the first position of use and the diameter of said elongated hoisting member may be larger than 30, preferably larger than 40 and even more preferably in the range of 60 or larger. Said ratio is oftentimes called the D/d ratio, where D is the diameter of the winch drum and d the diameter of the wire rope. A high D/d ratio has been shown to be par-

ticularly important for offshore winch applications. Traditionally winches and wire ropes used for offshore drilling applications have had a D/d ratio of around 30. In a system according to the present invention an increased D/d ratio from 30 to 60 increases the lifetime of the wire rope approximately fivefold, thus contributing to increased wire rope lifetime. The use of a single-layer winch with a large winch drum significantly contributes to the increased D/d ratio. Preferably also the sheaves in the system should have a large D/d ratio, with D now being the diameter of a sheave instead of the diameter of the winch drum. The sheave D/d ratio could also be in the range of 60 or larger. A person skilled in the art will understand that the diameter d of the wire rope will depend on the capacity of the system in which it is to be used, the number of parallel wire ropes and the required safety factor. The safety factor of the wire rope should preferably be 3 or even larger. As an example, in a system with a safe working load of 1250 short tons, six parallel wire ropes with a diameter of 66 millimetres may run over two-parts blocks in the derrick. Sheaves and winch drum may have a D/d ratio of 60 or even larger, thus requiring diameters in the range of four meters. Various embodiments of the hoisting system according to the invention may be adapted to lift from 200 to 750 short tons in well intervention applications, and even up to 2000 short tons in drilling operations.

In one embodiment the winch drive means may be a plurality of electric drive means. By using a plurality of smaller drive means, instead of one large drive means, system safety and flexibility may be further improved. In case of failure in one of several electric drive means, the system may still be run within its safety limits, thus also reducing downtime.

Said electric drive means may be permanent magnet motors, such as permanent magnet AC synchronous motors. Such permanent magnet motors are known to be compact, reliable and cost-efficient while at the same time requiring little maintenance.

Each of said plurality of permanent magnet motors may be connected to said winch via a separate gear. Each of said gears may further be connected to a separate gear shifting means adapted to shift gears and to disconnect said permanent magnet motor from the winch. A mal-functioning non-disconnected permanent magnet motor will rotate with the winch drum, produce energy and therefore constitute a potential safety hazard. It is therefore advantageous to be able to disconnect each of the permanent magnet motors, should it be required. In contrast to traditional draw-works, at least some gearing according to this embodiment is done directly at the winch. Load accel-

eration will also be significantly better compared to traditional draw-works, thus leading to a quicker response and less energy-consumption. The permanent magnet motors may therefore be run at a fixed, optimized speed, while wire speed is regulated through the winch gears. Said separate gear may be a two-step gear wherein in a first gear the winch is adapted to lift and/or lower a first load, and wherein in a second gear the winch is adapted to perform multiple lifting and lowering operations of a second load. The first gear and the first load may correspond to a mode where the system is used for lifting and/or lowering a drill string, where much power but not so much speed is required. The second gear and the second load may correspond to tripping with a drill stand, where less power but more speed is required. The gear shifting means may be adapted to switch between the two gears and to disconnect the permanent magnet motor, to which the gear is connected, from said winch.

In one exemplary embodiment the gear shifting means may be adapted to shift gear under load. This may be done by running each motor, one or a few at the time, consecutively in a slight overspeed, and change gear while in overspeed, while the rest of the motors are under load. This may speed up processing time and the transmission between slow and fast speed. A person skilled in the art will understand that the motors and motor speed may be controlled by a winch control unit, which may be a PLC or the like.

In one embodiment the elongated hoisting member may be a galvanized steel wire. Galvanized steel wires have not conventionally been used in heave compensation on offshore rigs. The fact that wires typically have been worn out in about two weeks did not justify, from a cost perspective, the use of galvanized wires. However, together with an offshore hoisting system according to the invention, where the lifetime of wires is significantly increased, the use of galvanized wires may further increase the lifetime of the wire, and thus further reduce costs over time.

In one embodiment said elongated hoisting member may be a wire rope including more than six strands. This will result in a smoother surface of the wire rope and thus reduced risk of the wire rope getting tangled compared to wire ropes with fewer strands which have traditionally been used in these kinds of operations. Together with the fact that the wire is provided in a single-layer, and preferably in a helical groove, on the winch drum, this will further lead to reduced wear and thus increased lifetime of the wire rope.

In one embodiment said winch may comprise a removable shell defining an outer layer of said winch drum, and wherein the winch with said shell defines said first position of

use, and wherein said winch without said shell defines a second position of use wherein the winch is adapted to accommodate multiple layers of said elongated hoisting member. In this alternative embodiment the winch may also for instance serve as a subsea hoisting winch, i.e. for lowering or lifting loads to or from a seabed. Such operations will require a much longer wire rope than for instance heave-compensated derrick operations. Still, subsea hoisting operations are not frequently performed, hence wear of the wire rope is not a big issue. This embodiment may save cost and space as one winch may be used for several purposes for which, traditionally, two or more winches have been required.

In one embodiment said removable shell may include a plurality of shell segments adapted to be assembled to define said removable shell. This may make it easier to assemble and dis-assemble the shell. In one embodiment the shell may include three segments of substantially equal size, i.e. each covering a sector of substantially 120° around the winch drum core.

It has been found that by implying one or more of the various embodiments described above, the average lifetime of a wire used on an offshore drilling rig may be increased from two weeks, which is the current situation, up to as much as five years and even more.

There is also described an offshore drilling rig comprising a system according to any of the preceding claims.

In the following is described an example of a preferred embodiment illustrated in the accompanying drawings, wherein:

Fig. 1 shows, in a perspective view, a winch as used in a system according to the present invention;

Fig. 2 shows, in a side view, a system according to the present invention;

Fig. 3 shows, in a schematic view, a hoisting system according to prior art;

Fig. 4 shows, in a schematic view, a hoisting system according to the present invention;

Fig. 5 shows, in a perspective view, a winch in a first position of use;

Fig. 6 shows the winch from Fig. 5 in a second position of use;

Fig. 7a shows a winch drum segment in two different views; and

Fig. 7b shows a winch drum support means in two different views.

In the following identical reference numerals indicate identical or similar features on the figures, which are shown simplified and/or schematic.

5 Figure 1 shows a winch 2 suitable for use in a system according to the present invention as shown in Figure 2 and discussed below. The winch 2 comprises a winch drum 23 formed with helical grooves 231, into which four parallel elongated hoisting members 21, 21', 21'', 21''' in the form of galvanized steel wire ropes with high quality polymer plastic inserts are wound around the winch drum 23 in a single layer. The wires
10 21, 21', 21'', 21''' are connected to the winch drum 23 by means of not shown wire clamps. The helical grooves 231 prevent cross-over damage in each wire rope 21, 21', 21'', 21''' and between adjacent wire ropes 21, 21', 21'', 21'''. The winch 2 will be described more in detail with reference to figures 5 and 6 below.

In Figure 2 a system 1 according to the present invention is shown. A derrick 5 is
15 placed on a rig floor 10 of a not shown offshore drilling rig. The winch 2 is provided on the rig floor 10 and is provided with active heave compensation means 8, as shown schematically in Figure 4. The heave compensation means 8 is adapted to control the winch 2 so as to keep the height of a load 7, here shown as a drill string, constant relative to the seafloor. It will be understood that the four wire ropes 21, 21', 21'',
20 21''' run in parallel from the winch 2, but that only one wire rope 21 is visible in the shown side view. The wire rope 21 run over a crown block 51, with a sheave 51a, down around a travelling block 53, with sheave 53a, over the crown block 51 again at a second, not shown, sheave, down around a compensating sheave 57 and up to a
25 deadline anchor 58. In the shown embodiment, the compensating sheave 57 is connected to a deadline compensator 59. The functionality of the deadline compensator 59 will be well known to a person skilled in the art and is not discussed in any detail herein. The transmission in the shown system 1 is 2:1, in contrast to in the range of
16:1 in a conventional draw-works. In an alternative embodiment the winch 2 could even be a direct line winch, i.e. without any transmission.

30 In Figure 3 a prior art draw-works 6 with a 16:1 transmission is shown schematically and simplified. Upper sheaves 61a define a crown block 61, while lower sheaves 63a define a travelling block 63 connected to a load 7. This implies that for lowering or lifting a load 1 meter, the winch 2' has to pay out or reel in 16 metres of wire rope 22, respectively. The wire rope 22 thus undergoes numerous bending cycles over relative-

ly small sheaves 61a, 63a. The excessive ton/bending cycles imply a lifetime in the order of two weeks for such a system 6 used in active heave compensation on an off-shore drilling rig. A traditional cut-and-slip operation thus has to be performed to replenish the wire 22 before the operation can continue. The distal end of the wire 22 is connected to a deadline anchor 68 as will be known to a person skilled in the art.

For comparison, Figure 4 shows a simplified and schematic representation of a system 1 according to the present invention. The wire 21 only passes over one single sheave 51a in the crown block 51 and one single sheave 53a in the travelling block 53. The non-travelling end of the wire is connected to a deadline anchor 58, the system thus constituting a 2:1 transmission. Alternatively the distal end of the wire 21 may also be connected to a deadline compensator 59 via a compensator sheave 57, the latter embodiment corresponding to the system 1 shown on Figure 2. The features of the latter, alternative embodiment are shown in dashed lines in the figure. In the system 1 shown in Figure 4, the wire rope 21 undergoes significantly fewer bending cycles than the wire rope 22 shown in Figure 3 for several reasons:

- The sheaves 51a, 53a in the crown block 51 and travelling block 53 in the present system are larger than the sheaves 61a, 63a in the conventional draw-works 6, implying that the wire 21 will travel a longer distance on each sheave/ in contact with each sheave 51a, 53a before leaving the sheave 51a, 53a;
- There are fewer sheaves 51a, 53a in the system 1 according to the present invention where the transmission may be in the range of 1:1 (direct line) to 4:1, in contrast to conventional draw-works 6. The wire 21 thus "meets" fewer sheaves 51a, 53a;
- The overall distance travelled by the wire 21 on the so-called fast line side of the system 1 is shorter due to the reduced transmission; and
- The sheaves 51a, 53a may also be provided with a larger distance therebetween compared to the sheaves 61a, 63a of the prior art system 6.

In traditional draw-works 6, acceleration is hampered by a significant inertia loss in the plurality of fast-running small sheaves 61a, 63a. In a system 1 according to the present invention, however, acceleration will be more direct, hence increasing average hosting speed and thus reducing operation time. The winch 2 of the system as shown in Figure 4 is, as mentioned above, connected to a heave compensation means 8. The heave compensation means will typically include a not shown Motion Reference Unit, or the like, connected to a winch control unit as will be understood by a person skilled in the art. The heave compensation means 8 is therefore not discussed in further detail herein.

In Figure 5 a second embodiment of a winch 2 for use in a system 1 according to the present invention is shown. The winch 2 is shown with most of its drive means 3, in the form of twenty four permanent magnet motors (PMMs) 3, twelve on each side of the winch 2, exposed for the overview. The winch 2 is shown without wire ropes 21, 21', 21'', 21'''. The permanent magnet motors 3 are, in the shown embodiment, so-called PMSMs (permanent magnet ac synchronous motors) of 350kW each. Each PMM 3 is connected to the winch drum 23 via a separate gear 31. The gear 31 is, in the shown embodiment, a two-step planetary gear with functionality as described in the general part of the description. Each gear 31 is connected to a gear shifting means 32 and to the winch drum 23 through a not shown gear ring-pinion connection. The gear 31 and gear shifting means 32 ensure that the PMMs 3 may be operated at an optimized, constant speed while the hoisting speed of the winch 2 itself may be varied between a fast mode and a slower/power mode, wherein in the slower mode the winch is adapted to handle heavy loads 7, such as a whole drill string 7. Said driving means 3 would be the same on the winch 2 in Figure 1. The winch 2 in Figure 5 is shown in a first position of use A wherein the outer surface of the winch drum 23 is constituted by a removable shell 24, as will be discussed with reference to the following figures. Bolts 243 for connecting the removable shell 24 to support means 241 are also visible in the figure. The person skilled in the art will also notice that various electric and hydraulic supply lines are not shown in the figures. The gear shifting means 32 may be hydraulically or electrically operated.

Figure 6 shows the winch 2 from Figure 5 in a second position of use B wherein the removable outer shell 24 has been removed. In this second position of use, the winch 2 is adapted to accommodate multiple layers of wire rope 21 not shown in the figure. The same winch 2 may thus be utilized both in derrick operations in active heave compensation and as a subsea winch.

In Figure 7a one of three shell segments 241 constituting the removable shell 24 in Figure 5 is shown, both in a side view (right) and in a front view (left) The shell segments 241 may be connected to the winch 2 via support means 242, shown in Figure 7b as one of six crossbars connectable to a winch flange 244 (shown in Figure 6), both in a side view (right) and in a front view (left). The crossbars 242 may be fitted into openings/recesses 245 (shown in Figure 6) in the winch flange 244 and further bolted to the winch flange 244, and the shell segments 241 may be connected/bolted to the crossbars 242 to form a closed, removable shell 24.

C l a i m s

1. System (1) for hoisting a load (7) on an offshore rig, the system (1) comprising
5 - a winch (2) having a winch drum (23);
- drive means (3) for operating said winch (2);
- one or more sheaves (51a, 53a),
- an elongated hoisting member (21, 21', 21'', 21'''), such as a wire rope, adapted to run over said one or more sheaves (51a, 53a) and to connect said
10 winch (2) to the load (7), c h a r a c t e r i z e d i n that said winch drum (23), in a first position of use (A), is adapted to accommodate a single layer of said elongated hoisting member (21, 21', 21'', 21''').
2. System (1) according to claim 1, wherein the system (1) further comprises
15 two or more parallel elongated hoisting members (21, 21', 21'', 21''') connecting said winch (2) to said load (7).
3. System (1) according to claim 1 or 2, wherein said winch drum (23) is provided with a helical groove (231) for accommodating said single layer of elongated hoisting member (21, 21', 21'', 21''').
4. System (1) according to any of the preceding claims, wherein the system (1)
20 further comprises motion compensation means (8), such as a heave compensation means.
5. System (1) according to any of the preceding claims, wherein a ratio between the diameter of said winch drum (23) in the first position of use (A) and the diameter of said elongated hoisting member (21, 21', 21'', 21''') is larger than
25 30, preferably larger than 40 and even more preferably, 60 or larger.
6. System (1) according to any of the preceding claims, wherein said drive means (3) is a plurality of electric drive means.
7. System (1) according to claim 6, wherein said electric drive means (3) are permanent magnet motors.
- 30 8. System (1) according to claim 7, wherein each of said permanent magnet motor (3) is connected to said winch (2) via a separate gear (31).

9. System (1) according to claim 8, wherein said separate gear (31) is a two-step gear and wherein in a first gear the winch (2) is adapted to lift and/or lower a first load (7), and wherein in a second gear the winch is adapted to perform multiple lifting and lowering operations of a second load (7).
- 5 10. System (1) according to claim 8 or 9, wherein each of said separate gears (31) is connected to a separate gear shifting means (32) adapted to switch gears and to disconnect the permanent magnet motor (3), to which the gear (31) is connected, from said winch (2).
- 10 11. System (1) according to any of the preceding claims, wherein said elongated hoisting member (21, 21', 21'', 21''') is a galvanized steel wire.
12. System (1) according to any of the preceding claims, wherein said elongated hoisting member (21, 21', 21'', 21''') is a wire rope including more than six strands.
- 15 13. System (1) according to any of the preceding claims, wherein said winch (2) comprises a removable shell (24) defining an outer layer of said winch drum (23), and wherein the winch (2) with said removable shell (24) defines said first position of use (A), and wherein said winch (2) without said removable shell (24) defines a second position of use (B) wherein the winch (2) is adapted to accommodate multiple layers of elongated hoisting member (21, 21', 21'', 21''').
- 20 14. System according to claim 13, wherein said removable shell (24) includes a plurality of shell segments (241) adapted to be assembled so as to define said removable shell (24).
- 25 15. Offshore drilling rig comprising a system (1) according to any of the preceding claims.

1/7

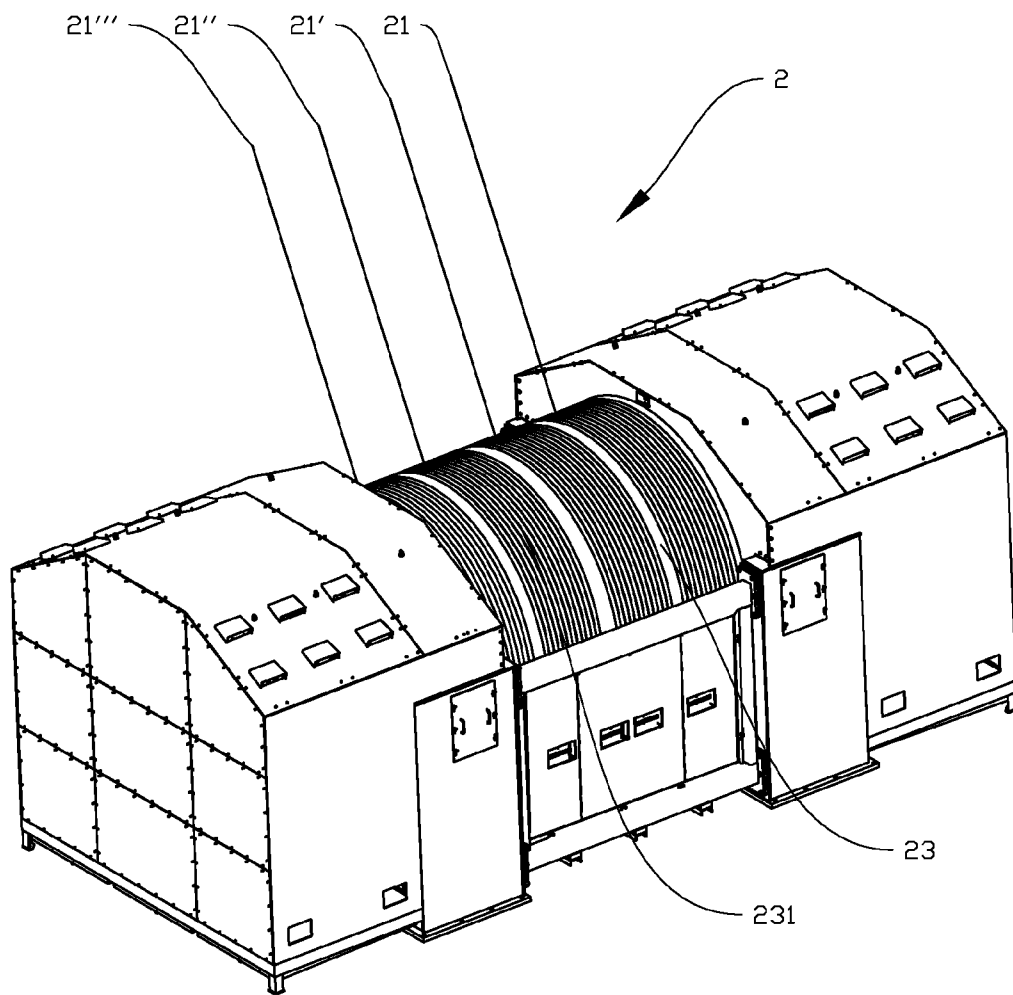

Fig. 1

2/7

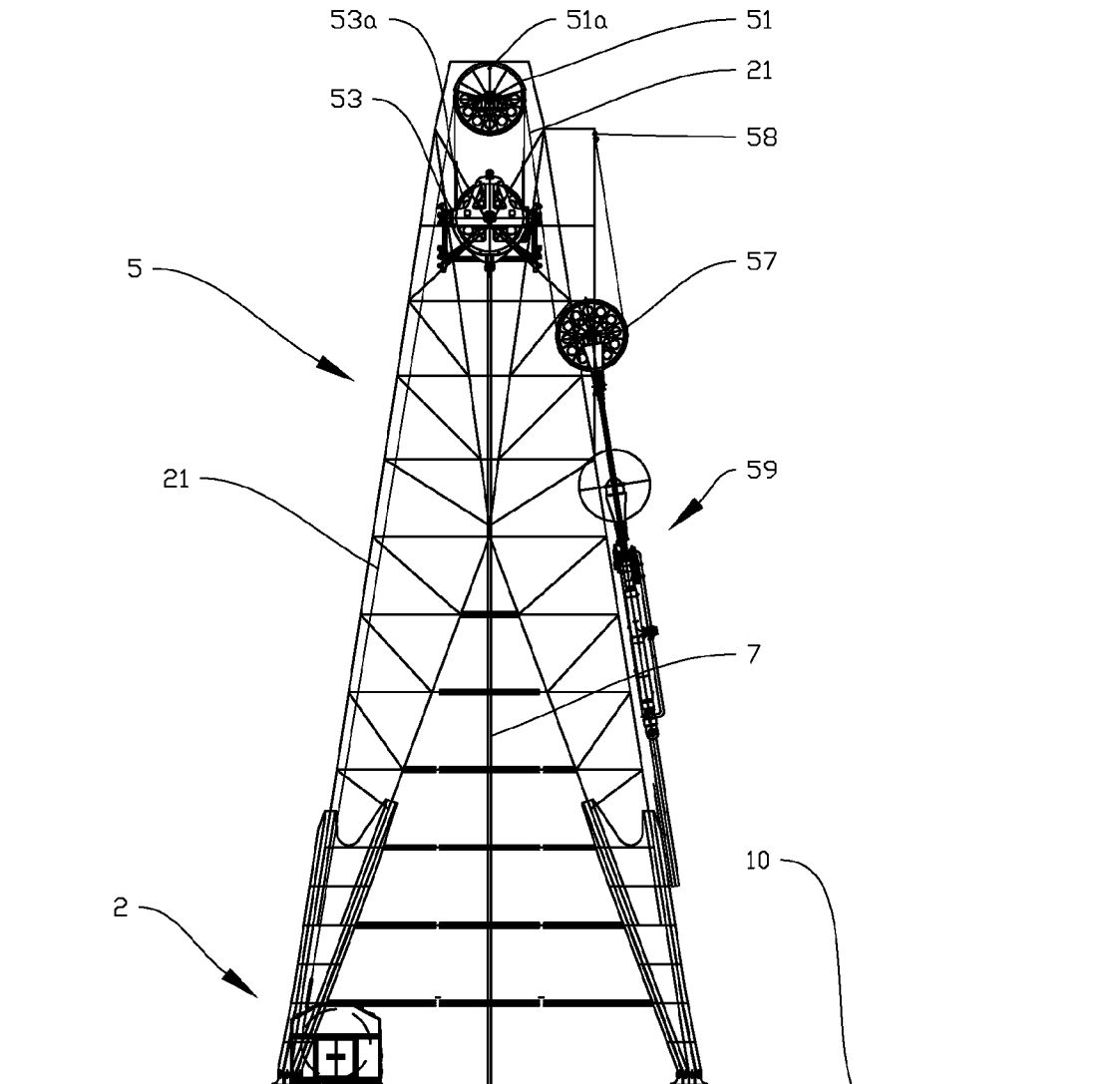

Fig. 2

3/7

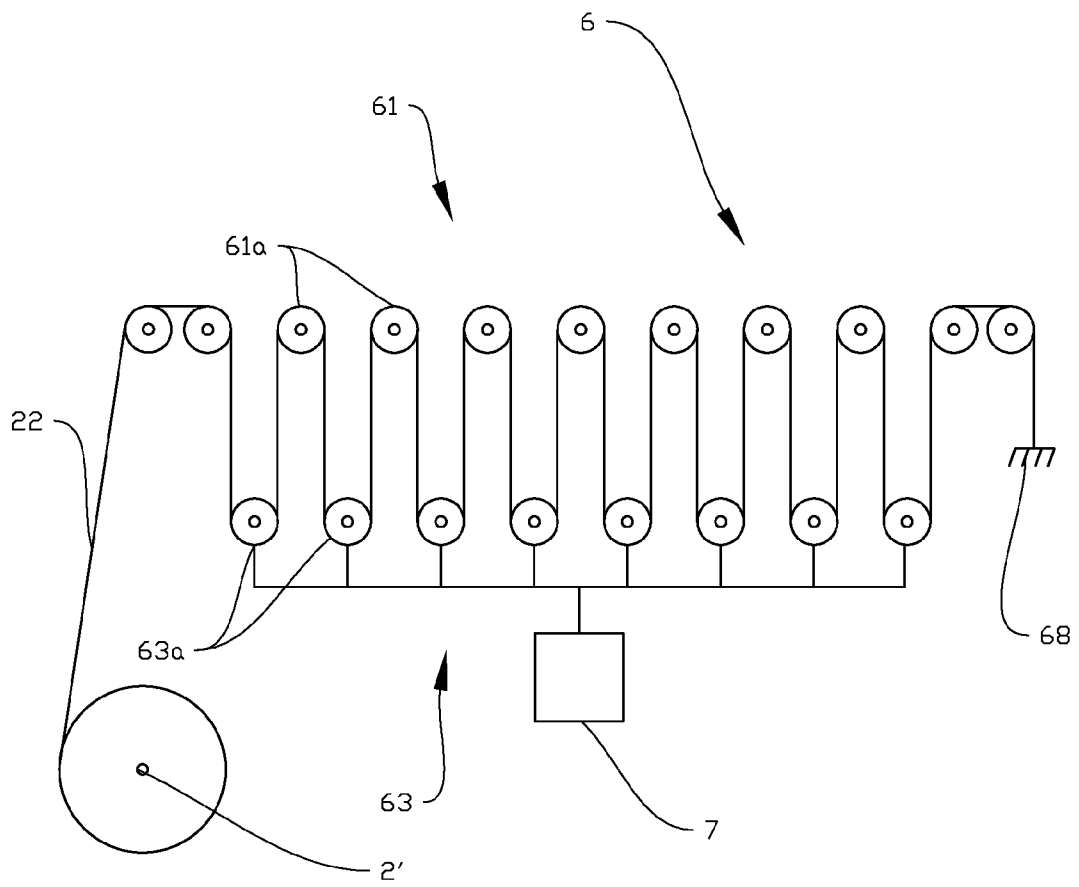

Fig. 3

4/7

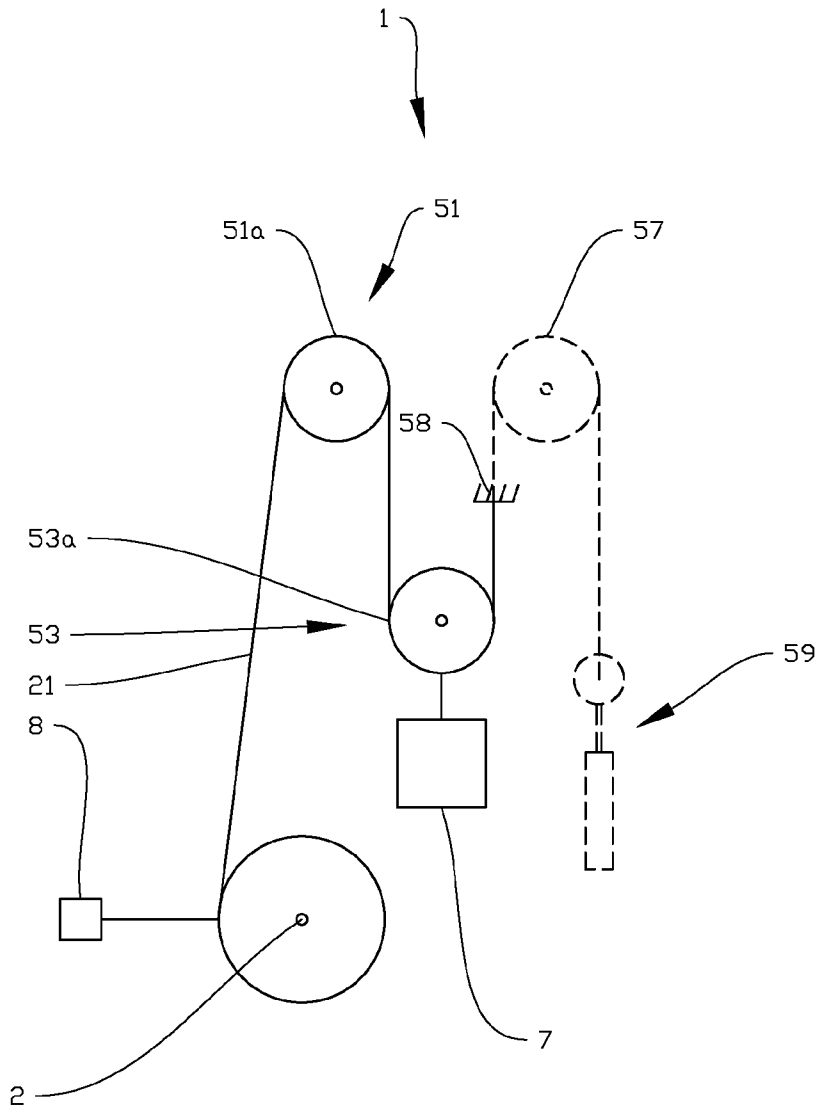

Fig. 4

5/7

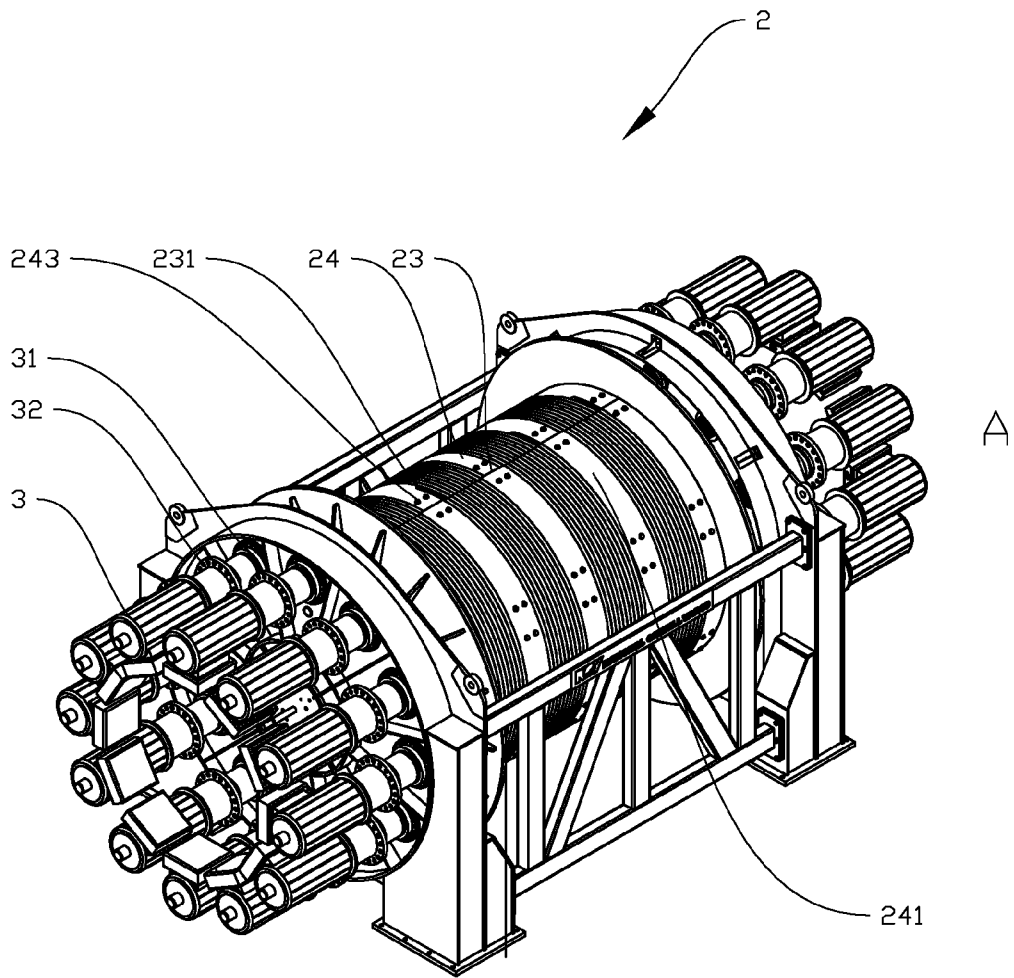

Fig. 5

6/7

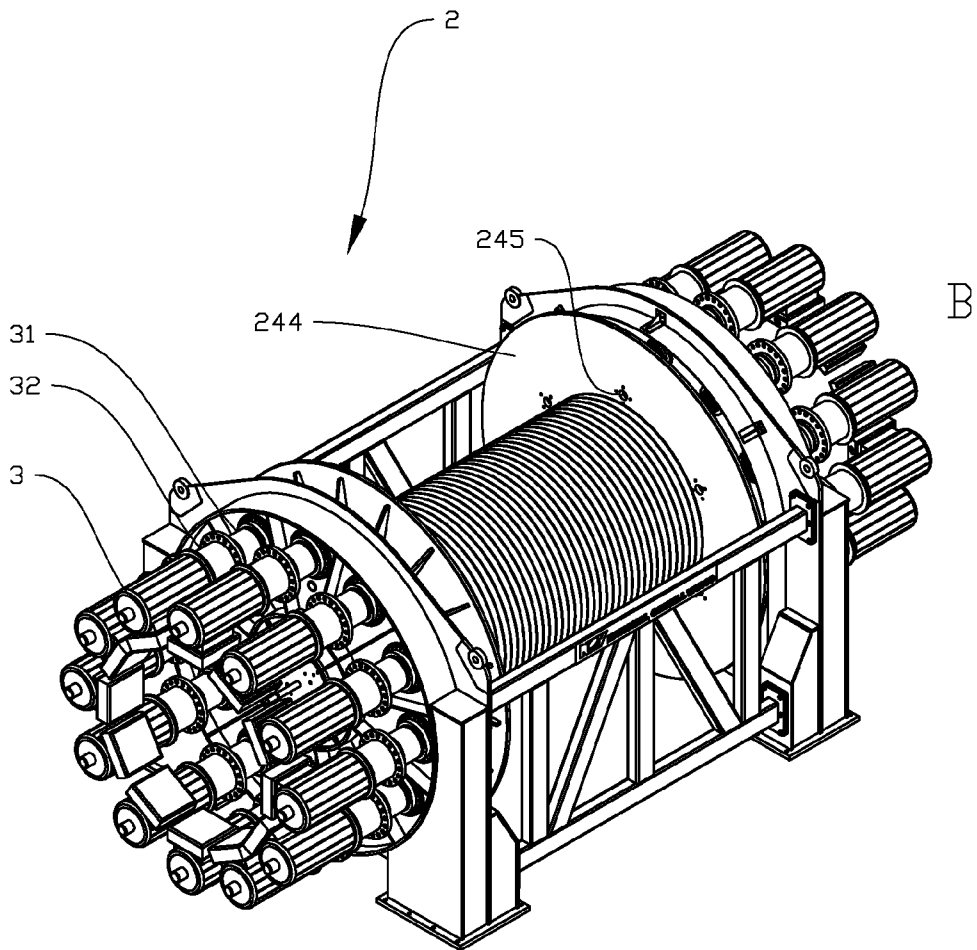

Fig. 6

7/7

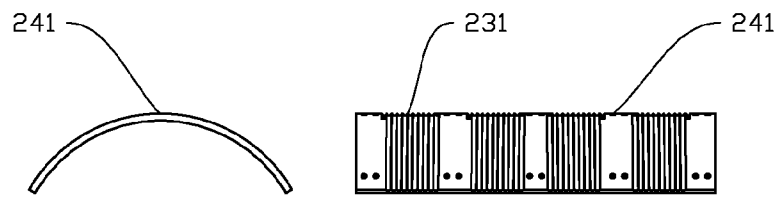

Fig. 7a

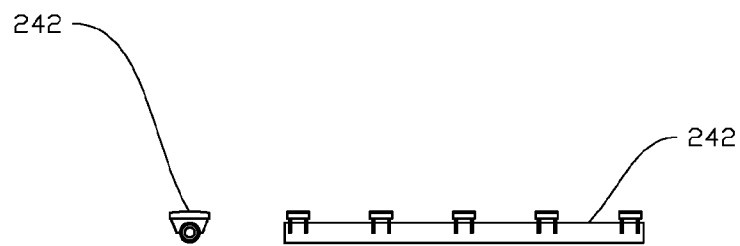

Fig. 7b

INTERNATIONAL SEARCH REPORT

International application No.

PCT/NO2014/050113

<p>A. CLASSIFICATION OF SUBJECT MATTER E21B 19/02 (2006.01), B66C 1/00 (2006.01), B66D 1/00 (2006.01), B66D 1/36 (2006.01), B66D 1/64 (2006.01) According to International Patent Classification (IPC) or to both national classification and IPC</p>														
<p>B. FIELDS SEARCHED</p> <p>Minimum documentation searched (classification system followed by classification symbols) E21B, B66D, B66C</p> <p>Documentation searched other than minimum documentation to the extent that such documents are included in the fields searched DK, NO, SE, FI: Classes as above.</p> <p>Electronic data base consulted during the international search (name of data base and, where practicable, search terms used) EPODOC, WPI, FULL TEXT: ENGLISH, GERMAN, FRENCH</p>														
<p>C. DOCUMENTS CONSIDERED TO BE RELEVANT</p> <table border="1"> <thead> <tr> <th>Category*</th> <th>Citation of document, with indication, where appropriate, of the relevant passages</th> <th>Relevant to claim No.</th> </tr> </thead> <tbody> <tr> <td>X Y A</td> <td>US 3717205 A (WILDERMAN, G.) 1973.02.20 Column 1 lines 59-64, column 2 lines 1-24, column 3 line 56—column 4 line 9 and figs. 2-4.</td> <td>1-2, 15 3-12 13-14</td> </tr> <tr> <td>Y</td> <td>Otto, S. et al., "INFLUENCE OF THE HOISTING DRUM WINDING SYSTEM ON THE END PLATE LOADS", INTERNATIONAL DESIGN CONFERENCE-DESIGN 2002, Dubrovnik, May 14 - 17, 2002, pages 1091-1096. Paragraph 2. Hoisting drum winding system according to LeBus, and figs. 1-2.</td> <td>3-12</td> </tr> <tr> <td>X Y</td> <td>US 4150727 A (HEPHERD, W. L.) 1979.04.24 Figs. 1-2, column 3 lines 29-32 & 43-46.</td> <td>1 3</td> </tr> </tbody> </table>			Category*	Citation of document, with indication, where appropriate, of the relevant passages	Relevant to claim No.	X Y A	US 3717205 A (WILDERMAN, G.) 1973.02.20 Column 1 lines 59-64, column 2 lines 1-24, column 3 line 56—column 4 line 9 and figs. 2-4.	1-2, 15 3-12 13-14	Y	Otto, S. et al., "INFLUENCE OF THE HOISTING DRUM WINDING SYSTEM ON THE END PLATE LOADS", INTERNATIONAL DESIGN CONFERENCE-DESIGN 2002, Dubrovnik, May 14 - 17, 2002, pages 1091-1096. Paragraph 2. Hoisting drum winding system according to LeBus, and figs. 1-2.	3-12	X Y	US 4150727 A (HEPHERD, W. L.) 1979.04.24 Figs. 1-2, column 3 lines 29-32 & 43-46.	1 3
Category*	Citation of document, with indication, where appropriate, of the relevant passages	Relevant to claim No.												
X Y A	US 3717205 A (WILDERMAN, G.) 1973.02.20 Column 1 lines 59-64, column 2 lines 1-24, column 3 line 56—column 4 line 9 and figs. 2-4.	1-2, 15 3-12 13-14												
Y	Otto, S. et al., "INFLUENCE OF THE HOISTING DRUM WINDING SYSTEM ON THE END PLATE LOADS", INTERNATIONAL DESIGN CONFERENCE-DESIGN 2002, Dubrovnik, May 14 - 17, 2002, pages 1091-1096. Paragraph 2. Hoisting drum winding system according to LeBus, and figs. 1-2.	3-12												
X Y	US 4150727 A (HEPHERD, W. L.) 1979.04.24 Figs. 1-2, column 3 lines 29-32 & 43-46.	1 3												
<p><input type="checkbox"/> Further documents are listed in the continuation of Box C. <input checked="" type="checkbox"/> See patent family annex.</p>														
<p>* Special categories of cited documents:</p> <table border="0"> <tr> <td style="vertical-align: top;"> <p>"A" document defining the general state of the art which is not considered to be of particular relevance</p> <p>"E" earlier application or patent but published on or after the international filing date</p> <p>"L" document which may throw doubts on priority claim(s) or which is cited to establish the publication date of another citation or other special reason (as specified)</p> <p>"O" document referring to an oral disclosure, use, exhibition or other means</p> <p>"P" document published prior to the international filing date but later than the priority date claimed</p> </td> <td style="vertical-align: top;"> <p>"T" later document published after the international filing date or priority date and not in conflict with the application but cited to understand the principle or theory underlying the invention</p> <p>"X" document of particular relevance; the claimed invention cannot be considered novel or cannot be considered to involve an inventive step when the document is taken alone</p> <p>"Y" document of particular relevance; the claimed invention cannot be considered to involve an inventive step when the document is combined with one or more other such documents, such combination being obvious to a person skilled in the art</p> <p>"&" document member of the same patent family</p> </td> </tr> </table>			<p>"A" document defining the general state of the art which is not considered to be of particular relevance</p> <p>"E" earlier application or patent but published on or after the international filing date</p> <p>"L" document which may throw doubts on priority claim(s) or which is cited to establish the publication date of another citation or other special reason (as specified)</p> <p>"O" document referring to an oral disclosure, use, exhibition or other means</p> <p>"P" document published prior to the international filing date but later than the priority date claimed</p>	<p>"T" later document published after the international filing date or priority date and not in conflict with the application but cited to understand the principle or theory underlying the invention</p> <p>"X" document of particular relevance; the claimed invention cannot be considered novel or cannot be considered to involve an inventive step when the document is taken alone</p> <p>"Y" document of particular relevance; the claimed invention cannot be considered to involve an inventive step when the document is combined with one or more other such documents, such combination being obvious to a person skilled in the art</p> <p>"&" document member of the same patent family</p>										
<p>"A" document defining the general state of the art which is not considered to be of particular relevance</p> <p>"E" earlier application or patent but published on or after the international filing date</p> <p>"L" document which may throw doubts on priority claim(s) or which is cited to establish the publication date of another citation or other special reason (as specified)</p> <p>"O" document referring to an oral disclosure, use, exhibition or other means</p> <p>"P" document published prior to the international filing date but later than the priority date claimed</p>	<p>"T" later document published after the international filing date or priority date and not in conflict with the application but cited to understand the principle or theory underlying the invention</p> <p>"X" document of particular relevance; the claimed invention cannot be considered novel or cannot be considered to involve an inventive step when the document is taken alone</p> <p>"Y" document of particular relevance; the claimed invention cannot be considered to involve an inventive step when the document is combined with one or more other such documents, such combination being obvious to a person skilled in the art</p> <p>"&" document member of the same patent family</p>													
<p>Date of the actual completion of the international search</p> <p>06/08/2014</p>		<p>Date of mailing of the international search report</p> <p>08/08/2014</p>												
<p>Name and mailing address of the ISA</p> <p>Nordic Patent Institute Helgeshøj Allé 81 DK - 2630 Taastrup, Denmark. Facsimile No. + 45 43 50 80 08</p>		<p>Authorized officer</p> <p>Al-Amiri, Thamir Jassim Telephone No. +47 22 38 75 37</p>												

INTERNATIONAL SEARCH REPORT
Information on patent family members

International application No.

PCT/NO2014/050113

Patent document cited in search report / Publication date	Patent family member(s) / Publication date
US 3717205 A 1973.02.20	NONE
US 4150727 A 1979.04.24	NONE