

April 26, 1927.

U. G. LEE

1,625,902

MARINE WATER CLOSET

Filed Nov. 20, 1926

2 Sheets-Sheet 1

Fig. 1.

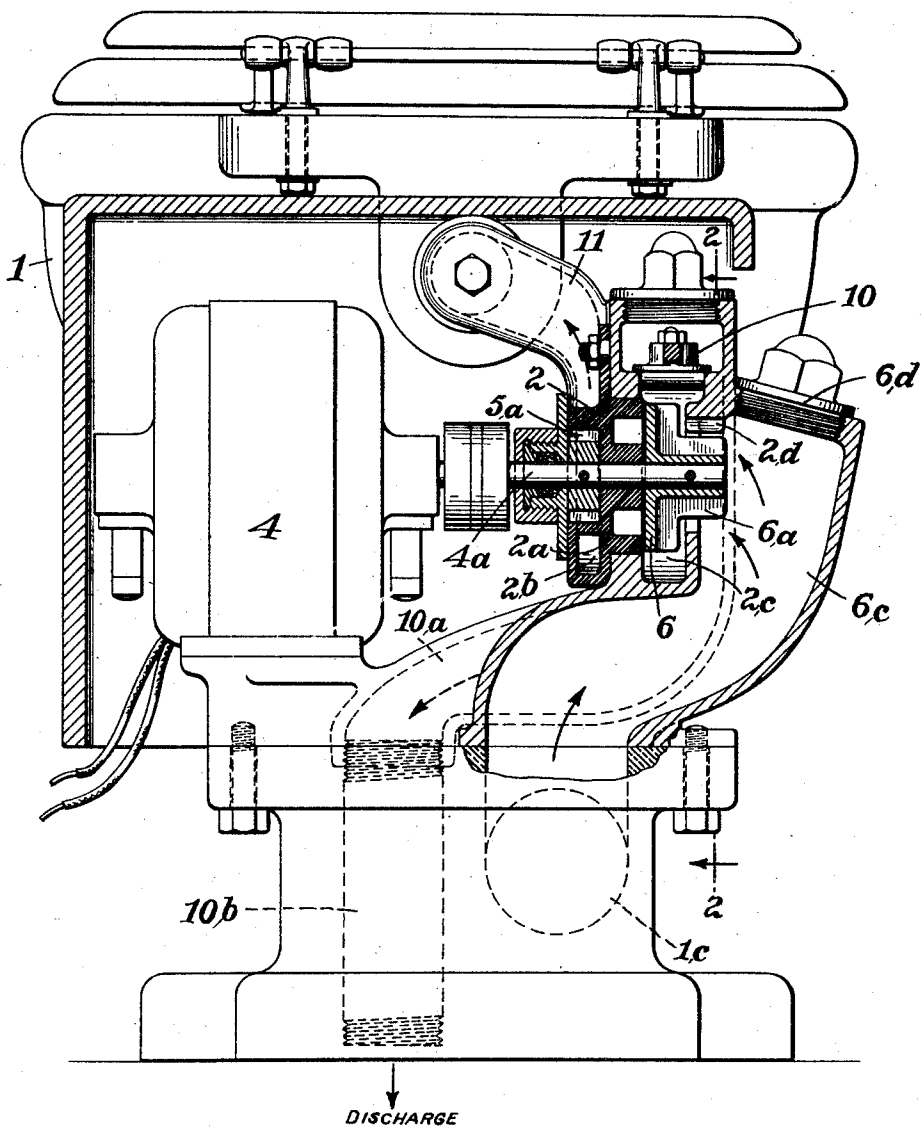

Inventor:

Ulysses G. Lee,
by Spear, Middleton, Dmaeson, Haer
Attys.

April 26, 1927.

1,625,902

U. G. LEE

MARINE WATER CLOSET

Filed Nov. 20, 1926

2 Sheets-Sheet 2

Fig. 3.

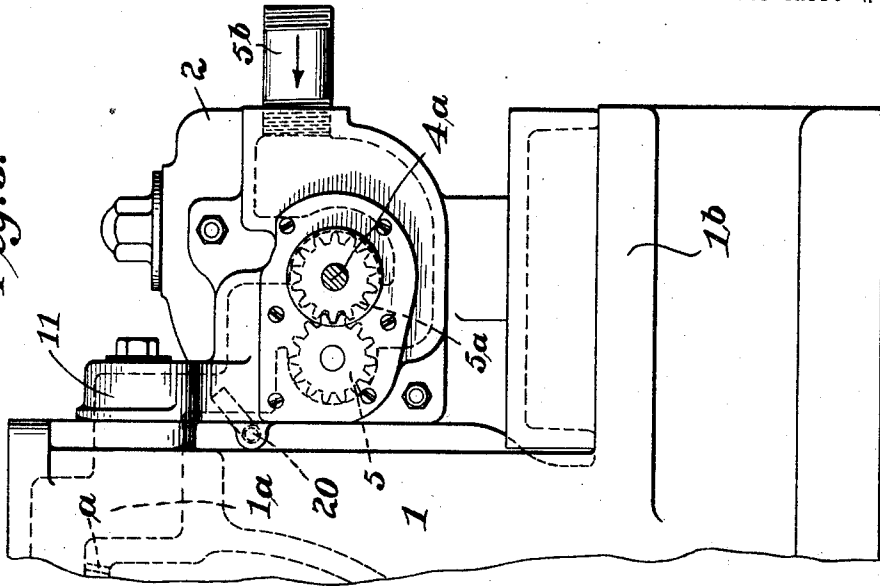
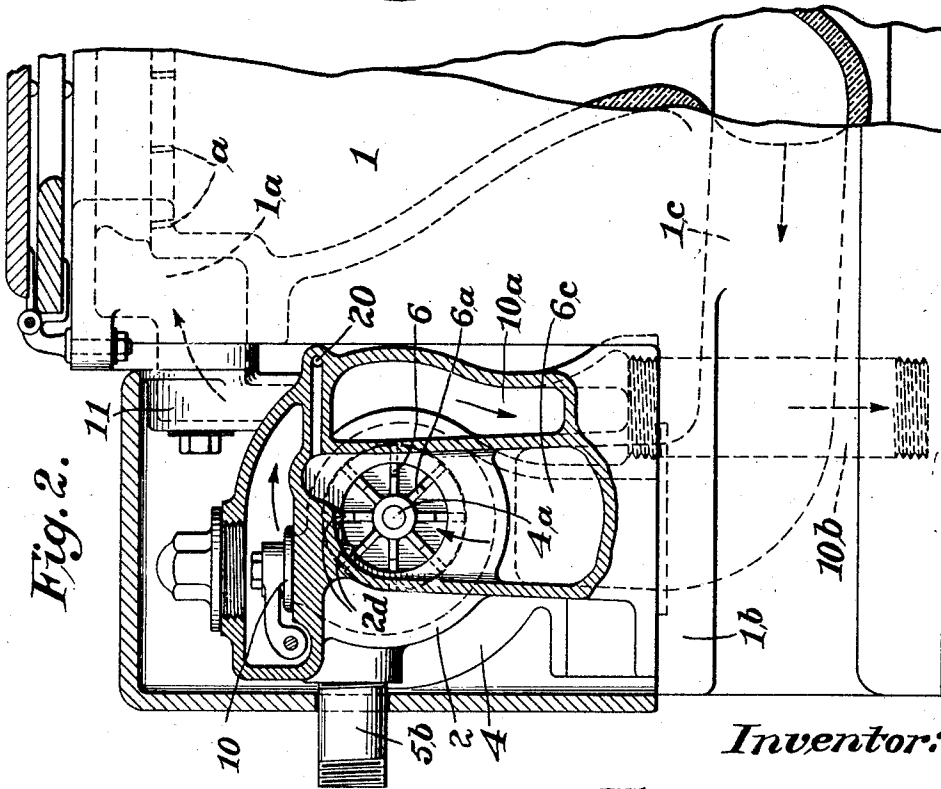

Fig. 2.



Inventor:

Ulysses G. Lee,
by *Spec. Middlem. Maedson. Haer*
Attys.

UNITED STATES PATENT OFFICE.

ULYSSES G. LEE, OF CHICAGO, ILLINOIS, ASSIGNOR TO U. G. LEE & CO. (INC.), OF CHICAGO, ILLINOIS, A CORPORATION OF ILLINOIS.

MARINE WATER-CLOSET.

Application filed November 20, 1926. Serial No. 149,687.

My present invention relates to improvements in water closets designed more especially for marine use and of the type using bowl supply and eduction pumps, such as disclosed in my United States application Serial No. 80,030, filed January 8th, 1926.

tion pump 6 which is of the rotary bladed impeller type such as disclosed in my aforesaid application. 55

Flushing water is led to the supply pump 5 by a supply pipe 5^b having its end tapped into an opening in the pump casing, and the supply pump chamber is also in communication with the flushing channel or rim of the bowl by the short pipe member 11. Due to the fact that the inlet pipe 5^b and outlet 11 are both located above the axis of the gear pump, the latter is thus always primed. 60 65

The invention aims to provide an exceedingly simple and economical construction and one which will not be liable to become clogged, and which, in the event of stoppage, can be easily cleaned out; and the invention includes the novel construction hereinafter described and defined by the appended claims.

The outlet pipe 1^c from the bowl communicates with a corresponding passage 6^c which extends up to a point opposite the end of the pump shaft and communicates with the chamber of the eduction pump 6. 70

An embodiment of the invention is shown in the accompanying drawings, in which—
Figure 1 is a rear elevation partly in section.

This eduction pump, being of the bladed or impeller type, tends to break up sewage, but to further and initially assist in this breaking up action I provide the hub of the impeller with projections 6^a and the wall of the pump chamber with coacting projections 2^d. With this construction it is impossible for the discharge pipe from the eduction pump casing to become clogged as the sewage is thoroughly broken up before passing the pump, and if there is any clogging it can only occur in the intake to the eduction pump due to the presence of cloth or other articles accidentally or carelessly dropped into the bowl. 75 80 85

In my present closet I provide for the ready removal of such objects by extending the bowl eduction passage up opposite the intake eye of the pump as shown in Fig. 1, and providing it at the upper end with a removable closure plug 6^d of large diameter, on the removal of which the eduction passage may be readily cleared.

Fig. 2 is a section on line 2—2 of Fig. 1, and

Fig. 3 is a view looking from the left of Fig. 1 with the motor and covering case removed.

The outlet side of the eduction pump communicates by way of check valve 10 with discharge passage 10^a and discharge pipe 10^b.

This closet is designed to have the same intermittent action as that described in my aforesaid application and to that end the eduction pump is made of greater capacity than the supply pump and a restricted port 20 is provided extending from the discharge pump intake to the discharge passage of the supply pump to allow for the removal of air from the discharge pump intake periodically. 100 105

Referring by reference characters to these figures, the numeral 1 designates the closet bowl having the customary annular flushing rim or conduit 1^a communicating with the bowl by the openings or water passages *a*.

The base is formed with a rearwardly (right Fig. 3) integral shelf portion 1^b which serves as a support for the flushing mechanism hereinafter described. This comprises a pump casing including the passages leading to and from the same and a bed plate (all formed integral), the latter being adapted to be bolted or otherwise suitably secured to the shelf 1^b, and to, in turn, support the motor 4, shown conventionally as an electric motor.

The pump casing 2 is divided by a partition 2^a into two compartments 2^b and 2^c which contain respectively the supply and eduction pumps 5 and 6. The motor is connected by a suitable flexible coupling to a pump shaft 4^a passing through a suitably packed opening in the wall of the pump casing, which pump shaft carries one of the rotary elements 5^a of the supply pump which is of the gear type as clearly shown in Fig. 3. The shaft also passes through an opening in the dividing wall or partition between the two pump chambers and terminates in this latter chamber and its end carries the educ-

Having thus described my invention, what I claim is:

- 1. In a marine water closet, a bowl having inlet and outlet passages, supply and eduction pumps in said passages, the eduction passage having a clean out plug adjacent the intake of the eduction pump.
- 2. In a marine water closet, a bowl, a water supply thereto, an eduction pump of the rotary impeller type having its intake connected with said bowl, said connection overlying the intake of the pump and having a clean out plug at its upper end.
- 3. In a marine water closet, a bowl having inlet and outlet passages, supply and eduction pumps in said passages, and comprising rotary elements located on a single shaft, the eduction pump being located on the end of the said shaft.
- 4. In a marine water closet, a bowl having inlet and outlet passages, supply and eduction pumps in said passages, and comprising rotary elements located on a single shaft, the eduction pump being located on the end of the said shaft, and the eduction passage having a clean out plug adjacent the intake of the pump.
- 5. In a marine water closet, the combination with the bowl having a shelf-like projection, of a one piece casting supported by said shelf and comprising a motor base and supply and eduction pump chambers and passages thereto, supply and eduction pumps in said chambers, and a motor supported by said base and operatively connected to both said pumps.
- 6. In a marine water closet, the combination with the bowl having a shelf-like projection, of a one piece casting supported by said shelf and comprising a motor base and supply and eduction pump chambers, and passages thereto, supply and eduction pumps in said chambers, a pump shaft driven by said motor and carrying supply and eduction pump elements, the eduction pump element being located on the end of said shaft and the adjacent intake passage having a clean out plug.

In testimony whereof, I affix my signature.
ULYSSES G. LEE.