



US 20080245605A1

(19) **United States**

(12) **Patent Application Publication**  
**Maeda et al.**

(10) **Pub. No.: US 2008/0245605 A1**

(43) **Pub. Date: Oct. 9, 2008**

(54) **METHOD AND APPARATUS FOR CONTROLLING ENGINE EXHAUST SOUND FOR VEHICLES**

**Publication Classification**

(51) **Int. Cl.**  
**F01N 1/00** (2006.01)

(52) **U.S. Cl.** ..... **181/254; 181/264**

(75) **Inventors:** **Kazushige Maeda**, Yokohama-shi (JP); **Akira Sasaki**, Zushi-shi (JP)

(57) **ABSTRACT**

Correspondence Address:  
**FOLEY AND LARDNER LLP**  
**SUITE 500**  
**3000 K STREET NW**  
**WASHINGTON, DC 20007 (US)**

An exhaust sound controlling method including reducing a flow rate of exhaust gas that passes through an exhaust path, to a first flow rate in accordance with increase in engine speed in a first engine speed region, and increasing the flow rate of exhaust gas to a second flow rate in accordance with increase in engine speed in a second engine speed region higher in engine speed than the first engine speed region. An exhaust sound controlling apparatus including a baffle plate and a valve that is operated to open a communication passage that communicates upstream and downstream sides of the baffle plate in an engine starting region, close the communication passage in an idling region and a low engine speed region, and open the communication passage and increase an opening of the valve as the engine speed rises in a high engine speed region.

(73) **Assignee:** **NISSAN MOTOR CO., LTD.**

(21) **Appl. No.:** **12/059,226**

(22) **Filed:** **Mar. 31, 2008**

(30) **Foreign Application Priority Data**

Apr. 4, 2007 (JP) ..... 2007-098526

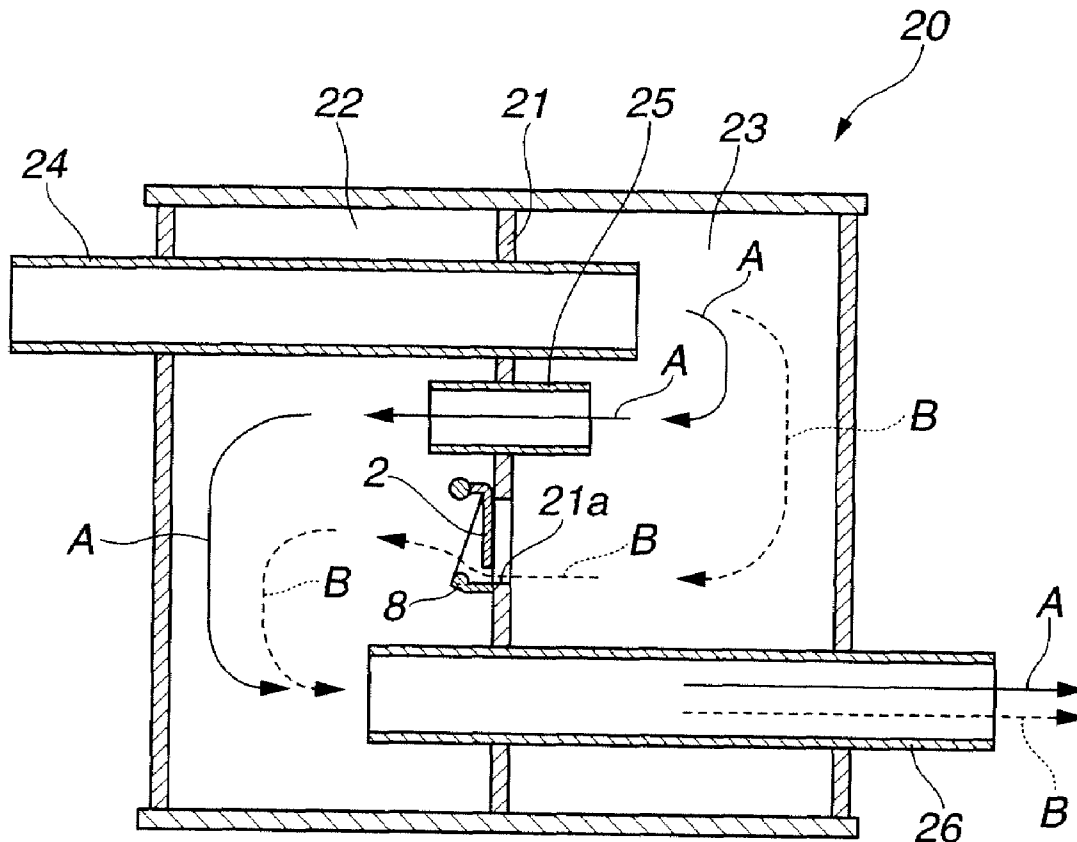

FIG.1

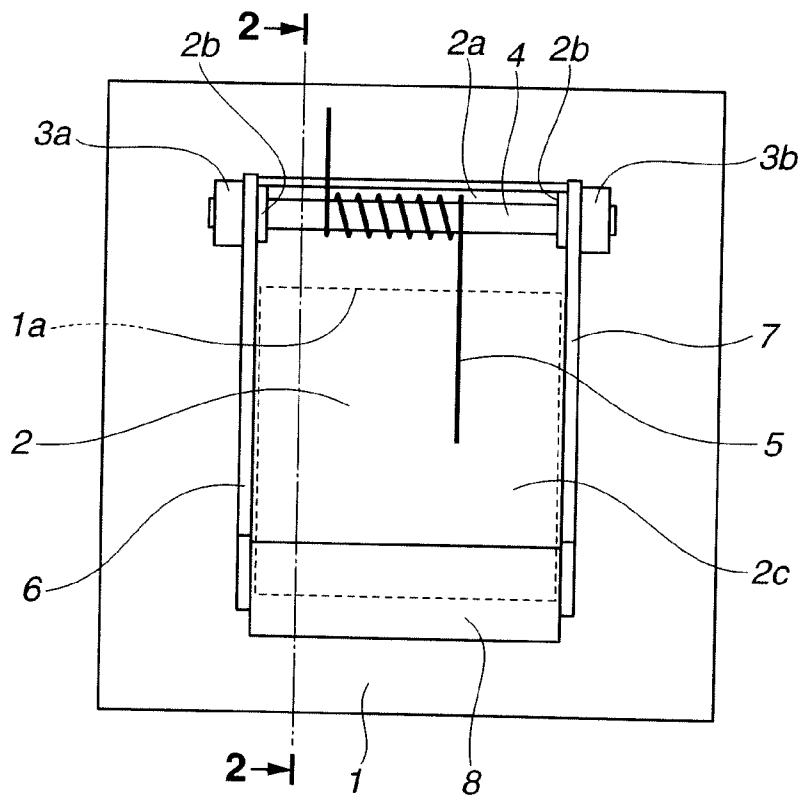
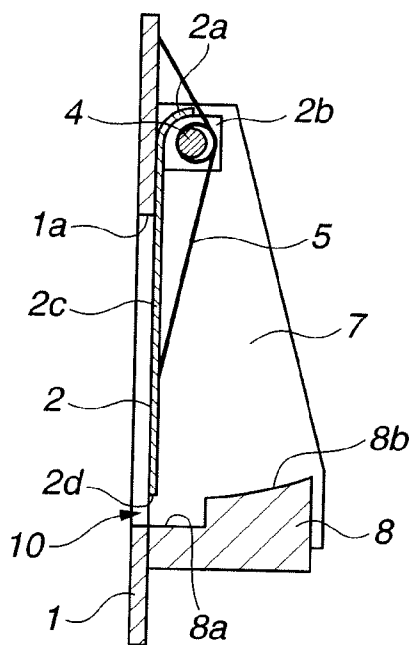
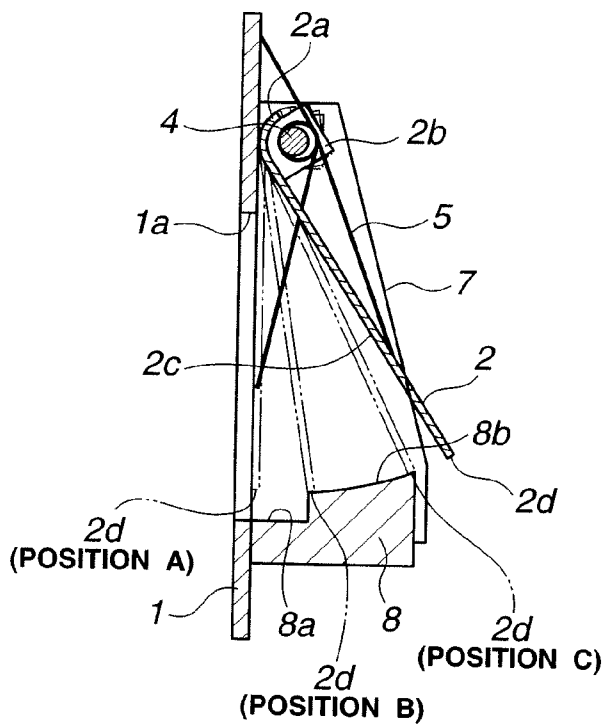

FIG.2



**FIG.3**



**FIG.4**

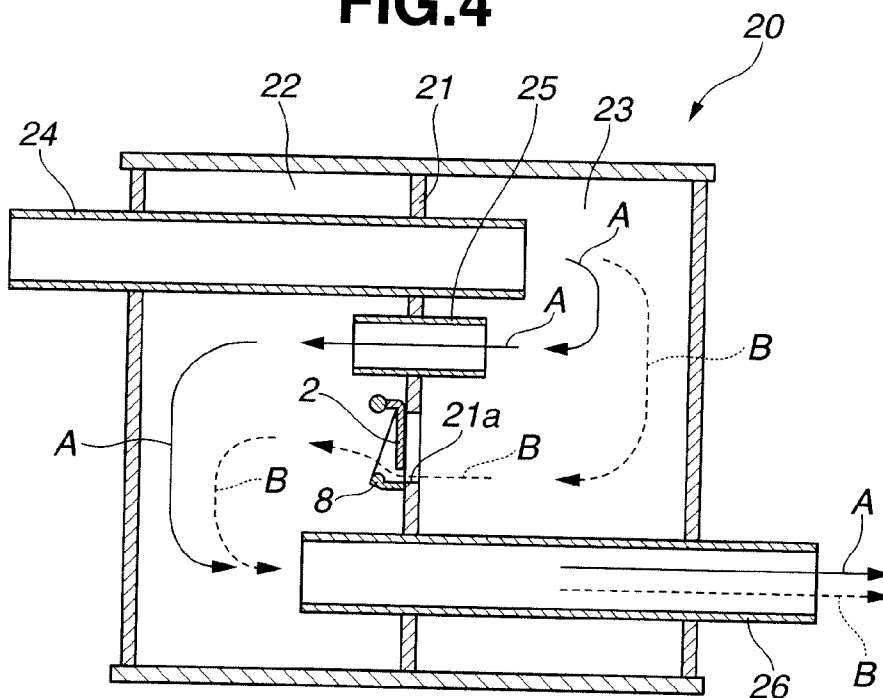

### FIG.5

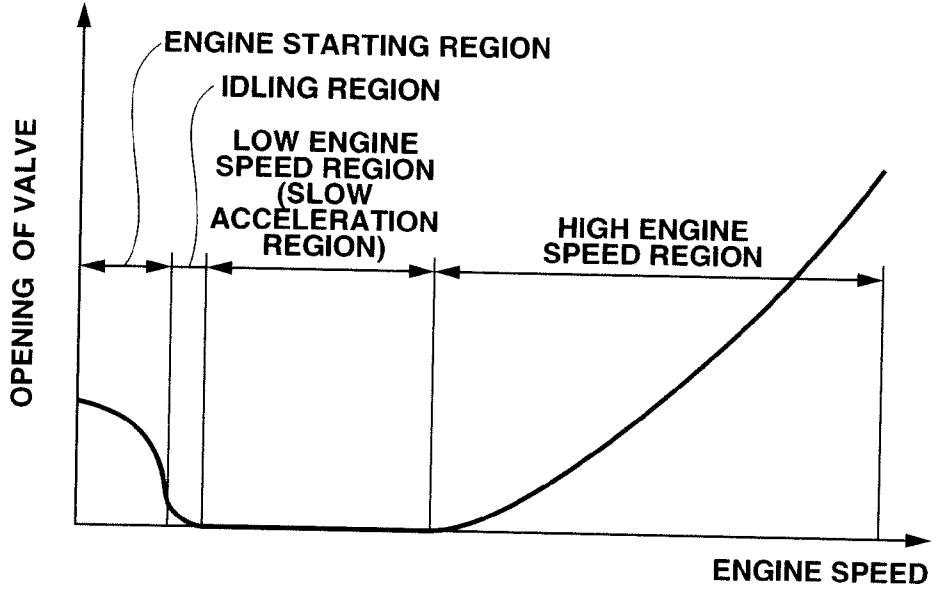

### FIG.6

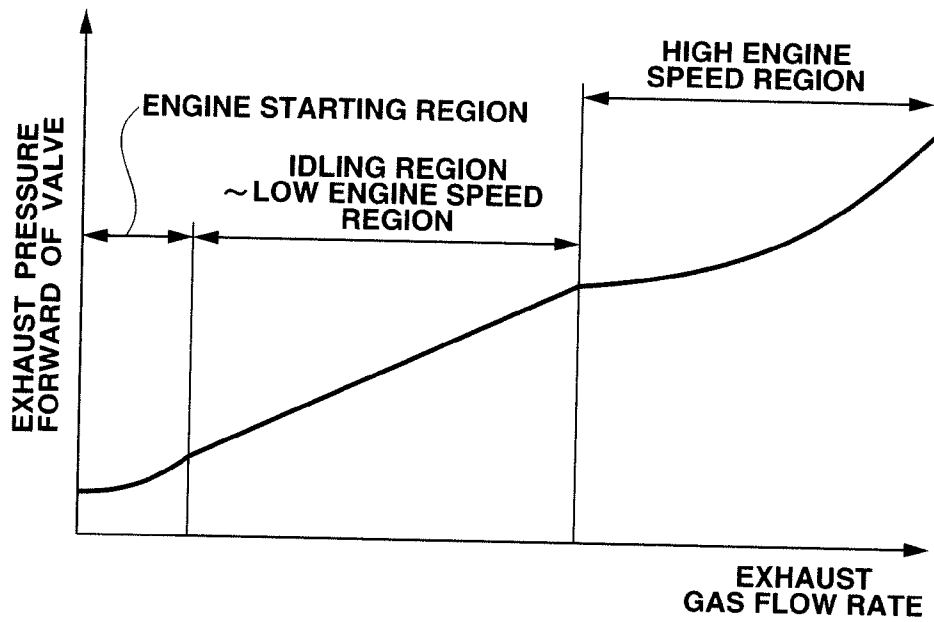

**FIG.7**

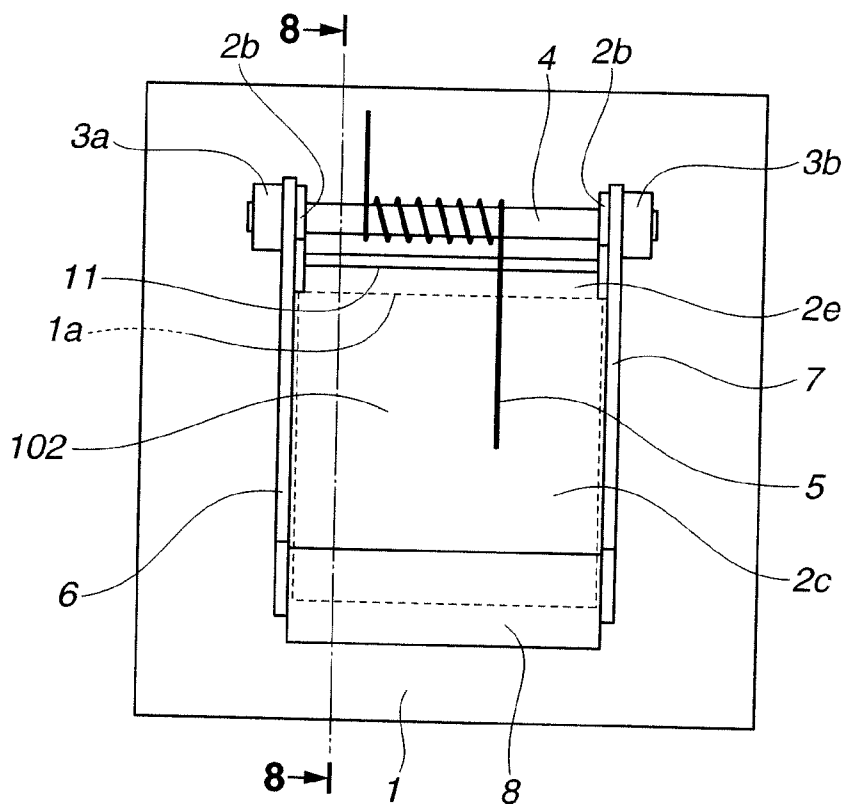

**FIG.8**

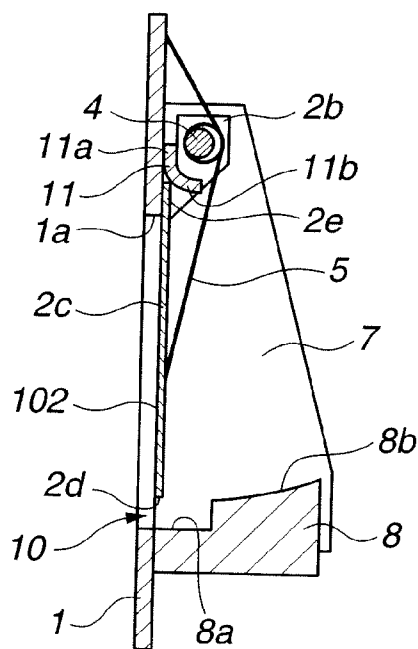

**FIG.9**

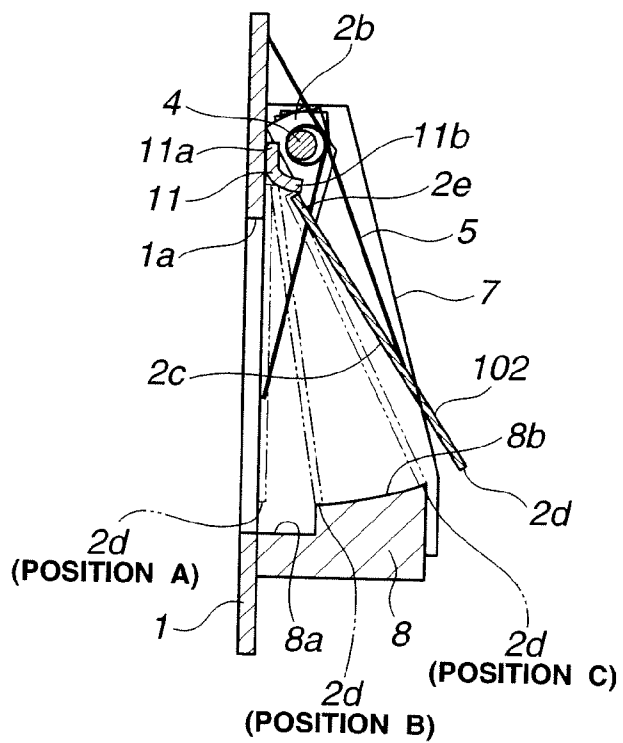

**FIG.10**

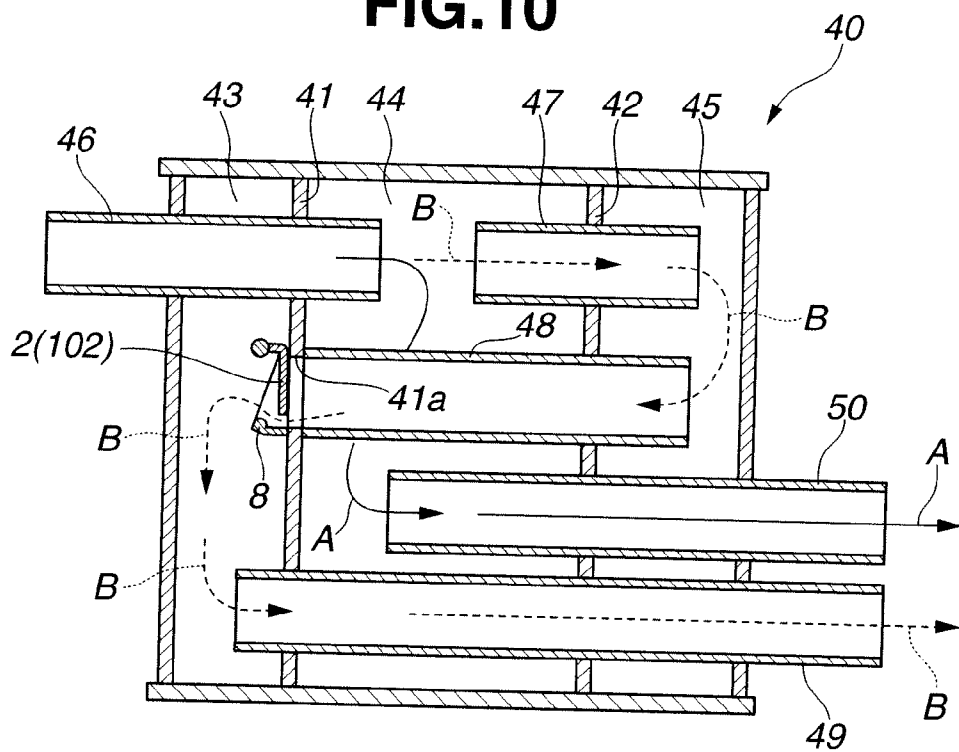

**METHOD AND APPARATUS FOR CONTROLLING ENGINE EXHAUST SOUND FOR VEHICLES**

**BACKGROUND OF THE INVENTION**

[0001] The present invention relates to method and apparatus for controlling engine exhaust sound that is emitted from an exhaust system of vehicles such as an automobile.

[0002] There have been conventionally proposed engine exhaust sound controlling apparatuses for vehicles which reduce exhaust sound in high engine speed region as well as in low engine speed region while reducing exhaust loss in high engine speed region.

[0003] Japanese Patent Application First Publication No. 8-109815 (corresponding to U.S. Pat. Nos. 5,614,699 and 5,739,483) indicates engine exhaust sound controlling apparatus for vehicles which includes a valve for conducting changeover of exhaust paths in response to exhaust pressure, a biasing member such as a spring which biases the valve in a closing direction of the valve against the exhaust pressure, and a spring constant changing member that reduces an increment of a reaction force of the biasing member when a rotational angle of the valve exceeds a predetermined value.

**SUMMARY OF THE INVENTION**

[0004] Recently, it has been required to reduce back pressure and vary a level of exhaust sound in an exhaust system in response to a vehicle running state. Specifically, when a vehicle engine is started, the exhaust sound would be increased to create a powerful sound to be heard by a passenger of the vehicle. When the engine is operated in an idling region and a low engine speed region, i.e., a slow acceleration state, the exhaust sound would be reduced to ensure a silence within the interior of the vehicle. Further, when the engine is operated in a high engine speed region, i.e., a rapid acceleration state, the exhaust sound would be increased again to create a good acceleration sound to be heard by the passenger.

[0005] However, in the apparatus of the conventional art as described above, when the engine is operated in the low engine speed region, the valve is kept in the closed state by the biasing member until a pressure in a muffler reaches a certain pressure value in order to ensure the silence within the interior of the vehicle. Further, in the conventional apparatus, the valve is kept closed even in the engine starting region. Thus, the conventional art shows the exhaust system that is constructed from a viewpoint of reducing the exhaust sound. Therefore, the apparatus of the conventional art fails to produce a powerful exhaust sound in the engine starting region.

[0006] It is an object of the present invention to provide a method and apparatus for controlling exhaust sound which is capable of producing a powerful exhaust sound in an engine starting region and ensuring silence in the interior of the vehicle in a low engine speed region.

[0007] In one aspect of the present invention, there is provided a method for controlling exhaust sound from an engine which is emitted through an exhaust path, the method comprising:

[0008] a first control step of reducing a flow rate of exhaust gas that passes through the exhaust path, to a first flow rate in accordance with increase in engine speed in a first engine speed region; and

[0009] a second control step of increasing the flow rate of exhaust gas to a second flow rate in accordance with increase

in engine speed in a second engine speed region in which the engine speed is higher than that in the first engine speed region.

[0010] In a further aspect of the present invention, there is provided an apparatus for controlling exhaust sound from an engine which is emitted through an exhaust path, the apparatus comprising:

[0011] a baffle plate that is disposed within the exhaust path so as to block a flow of exhaust gas in the exhaust path, the baffle plate being formed with an aperture;

[0012] a communication passage that communicates an upstream side of the baffle plate and a downstream side of the baffle plate with each other;

[0013] a valve that is so disposed as to cover a part of the aperture of the baffle plate and operated to open and close the communication passage; and

[0014] wherein the valve is operated to open the communication passage in an engine starting region, the valve is operated to close the communication passage in an idling region and a low engine speed region, and the valve is operated to open the communication passage and increase an opening of the valve as the engine speed rises in a high engine speed region.

[0015] In a still further aspect of the present invention, there is provided an apparatus for controlling exhaust sound from an engine which is emitted through an exhaust path, the apparatus comprising:

[0016] a baffle plate that is disposed within the exhaust path so as to block a flow of exhaust gas in the exhaust path, the baffle plate being formed with an aperture;

[0017] a valve that is so disposed as to cover a part of the aperture of the baffle plate, the valve being rotationally moveable relative to the baffle plate so as to be apart from the baffle plate in a direction of the flow of exhaust gas,

[0018] a biasing means for biasing the valve toward the baffle plate; and

[0019] an enclosure member that extends from the baffle plate so as to be opposed to the outer periphery of the valve when the valve is moved relative to the baffle plate,

[0020] wherein the valve has a contact position in which the valve is contacted with the baffle plate and covers the part of the aperture of the baffle plate, a small distance position in which the valve is apart from the baffle plate in the direction of the flow of exhaust gas with a first distance therebetween, an intermediate distance position in which the valve is apart from the baffle plate in the direction of the flow of exhaust gas with a second distance therebetween which is larger than the first distance, and a large distance position in which the valve is apart from the baffle plate in the direction of the flow of exhaust gas with a third distance therebetween which is larger than the first distance and the second distance, and

[0021] wherein when the valve is placed in the contact position, the valve cooperates with the baffle plate to define an opening between the outer periphery of the valve and a periphery of the aperture of the baffle plate,

[0022] when the valve is placed in the small distance position, the valve cooperates with the enclosure member to define a first clearance between the outer periphery of the valve and an opposing surface of the enclosure member that is opposed to the outer periphery of the valve,

[0023] when the valve is placed in the intermediate distance position, at least a part of the outer periphery of the valve is substantially contacted with the opposing surface of the enclosure member, and

[0024] when the valve is placed in the large distance position, the valve cooperates with the enclosure member to define a second clearance between the outer periphery of the valve and the opposing surface of the enclosure member, and the second clearance is increased as the third distance between the valve and the baffle plate becomes larger.

#### BRIEF DESCRIPTION OF THE DRAWINGS

[0025] FIG. 1 is a front view of a valve structure for use in an exhaust sound control apparatus of an embodiment of the present invention.

[0026] FIG. 2 is a sectional view of the valve structure, taken along line 2-2 of FIG. 1.

[0027] FIG. 3 is an explanatory diagram illustrating an operation of a valve of the valve structure of FIG. 1.

[0028] FIG. 4 is a sectional view of a muffler to which the exhaust sound control apparatus of the embodiment is applied.

[0029] FIG. 5 is a diagram showing a relationship between engine speed and opening of the valve.

[0030] FIG. 6 is a diagram showing a relationship between a flow rate of exhaust gas and a pressure forward of the valve.

[0031] FIG. 7 is a front view of a modification of the valve structure shown in FIG. 1.

[0032] FIG. 8 is a sectional view of the modified valve structure, taken along line 8-8 of FIG. 7.

[0033] FIG. 9 is an explanatory diagram illustrating an operation of the modified valve structure of FIG. 7.

[0034] FIG. 10 is a sectional view of a modification of the muffler shown in FIG. 4.

#### DETAILED DESCRIPTION OF THE INVENTION

[0035] Referring to FIG. 1 to FIG. 3, an exhaust sound controlling apparatus for vehicles, according to an embodiment of the present invention, now is explained. The exhaust sound controlling apparatus includes a valve structure shown in FIG. 1 and FIG. 2. As shown in FIG. 1 and FIG. 2, the valve structure includes valve 2 that is disposed on baffle plate 1. Baffle plate 1 is disposed within a muffler as explained later which is connected to a vehicle engine. Baffle plate 1 divides an interior of the muffler into a plurality of expansion chambers which constitute an exhaust path through which a flow of exhaust gas from the engine passes. Baffle plate 1 is so arranged as to block the flow of exhaust gas in the exhaust path.

[0036] Baffle plate 1 includes a generally rectangular-shaped aperture 1a as shown in FIG. 1. Aperture 1a extends through baffle plate 1. Valve 2 is disposed on a downstream side surface of baffle plate 1 with respect to the flow of exhaust gas and so arranged as to cover a part of aperture 1a. Specifically, a pair of supports 3a, 3b are arranged in a spaced and opposed relation to each other. Supports 3a, 3b are fixed to baffle plate 1 by a suitable fastening manner such as welding. Valve shaft 4 is supported at opposite end portions thereof by supports 3a, 3b. Valve 2 is rotatably mounted onto valve shaft 4.

[0037] Valve 2 is rotationally moveable relative to baffle plate 1 so as to be apart from baffle plate 1 in a direction of the flow of exhaust gas. Valve 2 is operated to open and close a communication passage which allows fluid communication between an upstream side expansion chamber and a downstream side expansion chamber which are disposed on an

upstream side and a downstream side of baffle plate 1 with respect to the flow of exhaust gas in the exhaust path.

[0038] Specifically, valve 2 is a generally rectangular-shaped plate member. Valve 2 includes curved end portion 2a at one end thereof, a pair of support portions 2b disposed on opposite sides of curved end portion 2a and planar valve body 2c connected with curved end portion 2a. Valve 2 has end peripheral surface 2d and two side peripheral surfaces which are disposed on an outer periphery of valve body 2c. End peripheral surface 2d is located at an opposite end of valve 2, namely, at a lower end of valve 2 when viewed in FIG. 2. The side peripheral surfaces are opposed to each other in the axial direction of valve shaft 4 and joined with end peripheral surface 2d. Curved end portion 2a is raised up from valve body 2c and formed into a curved shape. Support portions 2b are spaced from each other in an axial direction of valve shaft 4 and located between supports 3a, 3b. Valve shaft 4 extends through shaft insertion holes of support portions 2b and is supported by support portions 2b. Valve body 2c serves as a closing member that comes into contact and non-contact with baffle plate 1 so as to close the part of aperture 1a.

[0039] Curved end portion 2a is so curved as to have a predetermined radius that extends from a central axis of valve shaft 4. An outer circumferential surface of curved end portion 2a is opposed to baffle plate 1 and substantially in slide contact with baffle plate 1 during the rotational movement of valve 2 about valve shaft 4.

[0040] Torsion spring 5 is mounted to valve shaft 4 and biases valve body 2c of valve 2 toward baffle plate 1. When valve 2 is biased by torsion spring 5 so as to be placed in a position shown in FIG. 2, valve body 2c is contacted near curved end portion 2a with a part of baffle plate 1 which is located along an upper periphery of aperture 1a. Thus, a planar upstream side surface of valve body 2c is contacted with the downstream side surface of baffle plate 1 exclusive of aperture 1a. In other words, when valve 2 is urged to be in the position shown in FIG. 2, the upstream side surface of valve body 2c is aligned with the downstream side surface of baffle plate 1.

[0041] Aperture 1a is so configured as to be partially covered by valve body 2c of valve 2. Specifically, aperture 1a extends in the axial direction of valve shaft 4 so as to have an opening width equal to or slightly smaller than a width of valve 2 as shown in FIG. 1. As shown in FIG. 2, aperture 1a also extends in a direction perpendicular to the axial direction of valve shaft 4 beyond end peripheral surface 2d of valve 2. A part of aperture 1a which is located on an outside of end peripheral surface 2d of valve 2, namely, on a lower side of end peripheral surface 2d in FIG. 2, serves as opening 10 through which an upstream side expansion chamber and a downstream side expansion chamber disposed on an upstream side and a downstream side of baffle plate 1 with respect to the flow of exhaust gas in the exhaust path are communicated with each other when valve 2 is urged to be in the position shown in FIG. 2. Specifically, when valve 2 is biased by torsion spring 5 and placed in the position shown in FIG. 2, valve body 2c is in contact with baffle plate 1 and aperture 1a is covered by valve body 2c except for opening 10. Opening 10 is disposed between end peripheral surface 2d and an aperture forming rim of baffle plate 1 which defines a periphery of the rectangular-shaped aperture 1a. Opening 10 is always prevented from being covered by valve body 2c.

[0042] Valve guides 6, 7 and 8 serve as an enclosure member that extends from baffle plate 1 so as to surround the outer



periphery of valve 2. Valve guides 6, 7 and 8 cooperate with baffle plate 1 and valve 2 to define the communication passage that allows the fluid communication between the upstream side expansion chamber disposed on the upstream side of baffle plate 1 and the downstream side expansion chamber disposed on the downstream side of baffle plate 1.

[0043] Specifically, side valve guides 6 and 7 are disposed on both sides of valve 2 in an opposed and spaced relation thereto in the axial direction of valve shaft 4. Side valve guides 6 and 7 are formed into a plate shape and extend from the downstream side surface of baffle plate 1 in the direction of the flow of exhaust gas, namely, in a rotational direction of valve 2, so as to be opposed to the side peripheral surfaces of valve 2 during the rotational movement of valve 2 about valve shaft 4. End valve guide 8 is interposed between side valve guides 6 and 7 on the side of the other end of valve 2.

[0044] End valve guide 8 is opposed to and spaced from end peripheral surface 2d of valve 2 in the direction perpendicular to the axial direction of valve shaft 4. End valve guide 8 uprightly extends from the downstream side surface of baffle plate 1 and has a predetermined height. End valve guide 8 extends along the bottom-linear part of the generally rectangular-shaped periphery of aperture 1a in the axial direction of valve shaft 4. End valve guide 8 has clearance forming surface 8a and contact surface 8b on a side of valve 2 and valve shaft 4, namely, on an upper side of end valve guide 8 in FIG. 1 and FIG. 2. Specifically, clearance forming surface 8a extends uprightly from the downstream side surface of baffle plate 1. Clearance forming surface 8a cooperates with end peripheral surface 2d of valve 2 to form the clearance therebetween when valve 2 is rotated about valve shaft 4 and moved from the position shown in FIG. 2 in an opening direction thereof in which valve body 2c moves apart from baffle plate 1 to uncover aperture 1a. Contact surface 8b is connected with upright surface 8a through a step portion between clearance forming surface 8a and contact surface 8b. Contact surface 8b is so curved as to be approximately close to or contacted with end peripheral surface 2d of valve 2 during a further rotational movement of valve 2 about valve shaft 4 subsequent to passing through above clearance forming surface 8a. Thus, end peripheral surface 2d of valve 2 is approximately close to or in contact with contact surface 8b of end valve guide 8 when valve 2 is further rotated about valve shaft 4 subsequent to passing through above clearance forming surface 8a of end valve guide 8.

[0045] Valve 2 serves as a control valve that controls the flow of exhaust gas passing through the exhaust path. An operation of valve 2 is explained hereinafter with reference to FIG. 3. As shown in FIG. 3, valve 2 is urged to be placed in position A by the biasing force of torsion spring 5. In position A, valve body 2c is in contact with baffle plate 1, and aperture 1a of baffle plate 1 is covered with valve body 2c except for opening 10 that is disposed on the outside of end peripheral surface 2d of valve 2. In position A, opening 10 is prevented from being covered with valve body 2c and there is a clearance between end peripheral surface 2d of valve 2 and clearance forming surface 8a of end valve guide 8. That is, in position A, valve 2 is in a first open state in which there is no distance between valve body 2c and baffle plate 1 in the direction of the flow of exhaust gas, namely, in the rotational direction of valve 2, and the expansion chambers on the upstream and downstream sides of baffle plate 1 are commu-

nicated with each other through opening 10 and the clearance between end peripheral surface 2d and clearance forming surface 8a.

[0046] Next, as shown in FIG. 3, when an external force, i.e., an exhaust pressure, is applied to valve 2 in the direction of the flow of exhaust gas in which valve 2 moves apart from baffle plate 1, valve 2 is rotated about valve shaft 4 against the biasing force of torsion spring 5 and moved from position A to a position immediately before position B. At this time, a distance between baffle plate 1 and valve body 2c of valve 2 in the direction of the flow of exhaust gas is relatively small and an amount of the rotational movement of valve 2, namely, an opening of valve 2, is relatively small. During the rotational movement of valve 2, there exists the clearance between end peripheral surface 2d of valve 2 and clearance forming surface 8a of end valve guide 8. The fluid communication between the upstream side expansion chamber and the downstream side expansion chamber which are disposed on the upstream side and the downstream side of baffle plate 1 can be maintained through opening 10 and the clearance. Thus, valve 2 can be kept in the first open state while valve 2 is moved from position A to the position immediately before position B.

[0047] When the external force that is applied to valve 2 in the opening direction is increased, valve 2 is further rotated about valve shaft 4 against the biasing force of torsion spring 5. Valve 2 is placed in position B and then moved from position B to position C. At this time, the rotation amount of valve 2 becomes intermediate and the distance between baffle plate 1 and valve body 2c in the direction of the flow of exhaust gas becomes intermediate. During the rotational movement of valve 2 from position B to position C, at least a part of the outer periphery of valve 2, namely, end peripheral surface 2d of valve 2, is in substantially contact, namely, slide contact, with contact surface 8b of end valve guide 8. Therefore, the upstream side expansion chamber on the upstream side of baffle plate 1 can be prevented from being communicated with the downstream side expansion chamber on the downstream side of baffle plate 1. Thus, during the rotational movement of valve 2 from position B to position C, valve 2 is restrained from the first open state and kept in a closing state in which there is the intermediate distance between valve body 2c and baffle plate 1 in the direction of the flow of exhaust gas and the fluid communication between the upstream side expansion chamber and the downstream side expansion chamber which are disposed on the upstream and downstream sides of baffle plate 1 can be substantially prevented.

[0048] When the external force is further increased, valve 2 is further rotated about valve shaft 4 against the biasing force of torsion spring 5 and moved from position C in the opening direction to thereby be apart from end valve guide 8. At this time, the rotation amount of valve 2 becomes large and the distance between baffle plate 1 and valve body 2c in the direction of the flow of exhaust gas becomes large. End peripheral surface 2d of valve 2 is apart from contact surface 8b of end valve guide 8, and there is generated a clearance between end peripheral surface 2d and contact surface 8b. Therefore, the upstream side expansion chamber on the upstream side of baffle plate 1 can be communicated again with the downstream side expansion chamber on the downstream side of baffle plate 1 through the clearance between end peripheral surface 2d and contact surface 8b. Thus, when valve 2 is further rotationally moved from position C in the

opening direction, valve 2 is in a second open state in which the fluid communication between the upstream side expansion chamber and the downstream side expansion chamber which are disposed on the upstream and downstream sides of baffle plate 1 can be re-established through the clearance between end peripheral surface 2*d* and contact surface 8*b*. The clearance is increased as the distance between baffle plate 1 and valve body 2*c* in the direction of the flow of exhaust gas becomes larger. Further, in the second open state of valve 2, the opening of valve 2 and the angular position of valve 2 with respect to baffle plate 1, varies in accordance with the rotation amount of valve 2 and the distance between baffle plate 1 and valve body 2*c* in the direction of the flow of exhaust gas. That is, as the rotation amount of valve 2 and the distance between baffle plate 1 and valve body 2*c* in the direction of the flow of exhaust gas increases, the opening of valve 2 becomes larger.

[0049] Opening 10 and the clearance between baffle plate 1, valve body 2*c* and valve guides 6, 7 and 8 constitute the communication passage between the upstream side expansion chamber disposed on the upstream side of baffle plate 1 and the downstream side expansion chamber disposed on the downstream side of baffle plate 1. That is, the communication passage is formed by the aperture-forming rim of baffle plate 1, end peripheral surface 2*d* of valve body 2*c*, opposed surfaces of side valve guides 6 and 7 opposed in the axial direction of valve shaft 4, and clearance forming surface 8*a* and contact surface 8*b* of end valve guide 8.

[0050] Referring to FIG. 4, there is shown muffler 20 to which the exhaust sound controlling apparatus of the embodiment is applied. FIG. 4 shows a sectional view of muffler 20, taken in a direction of the flow of exhaust gas that passes through muffler 20. Muffler 20 may have a generally elliptic-shape in cross-section taken in a direction perpendicular to the direction of the flow of exhaust gas. As shown in FIG. 4, baffle plate 21 is disposed within muffler 20 so as to divide an interior of muffler 20 into two expansion chambers adjacent to each other, namely, first expansion chamber 22 and second expansion chamber 23 which are located on the left side and the right side of FIG. 4, respectively. First expansion chamber 22 and second expansion chamber 23 are thus separated from each other by baffle plate 21.

[0051] Inlet tube 24 extends into second expansion chamber 23 through an upstream end wall of muffler 20, first expansion chamber 22 and baffle plate 21. Inlet tube 24 has one end that outwardly projects from the upstream end wall of muffler 20 and is connected to the engine through an exhaust pipe, not shown. Inlet tube 24 has the other end that is opened within second expansion chamber 23. Inlet tube 24 serves as a first communication tube that communicates second expansion chamber 23 with the engine. Inlet tube 24 introduces the exhaust gas from the engine into second expansion chamber 23. Pass-through tube 25 extends through baffle plate 21 and communicates first expansion chamber 22 and second expansion chamber 23 with each other. Pass-through tube 25 has one end that is opened within second expansion chamber 23 and the other end that is opened within first expansion chamber 22. Tail tube 26 extends from first expansion chamber 22 to an outside of muffler 20 through baffle plate 21, second expansion chamber 23 and a downstream end wall of muffler 20. Tail tube 26 has one end that is opened within first expansion chamber 22 and the other end that outwardly projects from the downstream end wall of muffler 20 and is exposed to atmospheric air. Tail tube 26 serves as a second communication tube that communicates first expansion chamber 22 with

atmospheric air. First expansion chamber 22 and second expansion chamber 23 are larger in cross-sectional area than inlet tube 24, pass-through tube 25 and tail tube 26.

[0052] Baffle plate 21 has generally rectangular-shaped aperture 21*a* that is disposed parallel with pass-through tube 25. The valve structure described above with reference to FIG. 1 to FIG. 3 is provided on baffle plate 21 on a side of first expansion chamber 22. That is, valve 2 is arranged on a downstream side surface of baffle plate 21 which is exposed to first expansion chamber 22, such that valve body 2*c* covers aperture 21*a* except for opening 10. Valve 2, valve guides 6, 7 and 8 and baffle plate 21 cooperate with each other to define a communication passage that allows fluid communication between first expansion chamber 22 and second expansion chamber 23 in parallel with pass-through tube 25. The communication passage includes opening 10 that is disposed between end peripheral surface 2*d* of valve 2 and the aperture-forming rim of baffle plate 21 which defines the periphery of aperture 21*a*. The communication passage further includes the clearance that is formed between valve 2 and valve guides 6, 7 and 8 upon rotation of valve 2 about valve shaft 4. In the construction of muffler 20, the exhaust path extends through inlet tube 24, pass-through tube 25, tail tube 26, first expansion chamber 22, second expansion chamber 23 and the communication passage between first expansion chamber 22 and second expansion chamber 23.

[0053] In thus constructed muffler 20, exhaust sound generated from the engine is controlled in accordance with an operating condition of the engine. The exhaust sound is emitted to atmospheric air via a first route, a second route or both of the first and second routes in accordance with the engine operating condition. The first route is indicated by arrow A in FIG. 4 and the second route is indicated by arrow B in FIG. 4. The first route extends sequentially through inlet tube 24, second expansion chamber 23, pass-through tube 25, first expansion chamber 22 and tail tube 26. The second route extends sequentially through inlet tube 24, the communication passage between valve 2 and valve guides 6, 7 and 8, first expansion chamber 22 and tail tube 26. The second route thus bypasses pass-through tube 25.

[0054] Specifically, in an engine starting region in which a flow of exhaust gas from the engine starts at zero and increases, the exhaust sound from the engine is emitted from tail tube 26 to atmospheric air via the first route indicated by arrow A in FIG. 4. Further, in the engine starting region, valve 2 is rotationally moved from position A to the position immediately before position B as shown in FIG. 3. At this time, valve 2 is placed in the first open state in which second expansion chamber 23 is communicated with first expansion chamber 22 through the communication passage therebetween, namely, through opening 10 and the clearance between end peripheral surface 2*d* of valve 2 and clearance forming surface 8*a* of end valve guide 8. In this condition, the exhaust sound from the engine is emitted from tail tube 26 to atmospheric air via the second route in addition to the first route. Since the emission of the exhaust sound is performed via both the first route and the second route, the exhaust sound that is generated in the engine starting region can be enhanced as compared to the conventional exhaust sound controlling apparatus.

[0055] Further, when the engine speed is raised up to a predetermined engine speed which is in the idling region, valve 2 is rotationally moved to position B shown in FIG. 3 due to an increase in an exhaust pressure immediately for-

ward of valve 2, namely, an exhaust pressure within second expansion chamber 23, which is hereinafter referred to as a valve-forward pressure. Valve 2 is placed in the closing state in which end peripheral surface 2d is substantially contacted with contact surface 8b of end valve guide 8. In the closing state of valve 2, the opening of valve 2 and the sectional area of the communication passage are approximately zero. The exhaust sound from the engine is emitted to atmospheric air substantially only via the first route. As a result, the exhaust sound can be reduced.

[0056] When the engine speed is raised up to the low engine speed region in which the engine speed is higher than in the idling region, namely, when the engine is operated in a slow acceleration state, and the engine is maintained in the low engine speed region, the valve-forward pressure is further increased with the engine speed raise. Due to the increase in the valve-forward pressure, valve 2 is rotationally moved from position B to position C shown in FIG. 3. During the rotational movement from position B to position C, valve 2 is kept in the closing state. Therefore, the emission of the exhaust sound substantially only via the first route is maintained so that the exhaust sound can be reduced.

[0057] When the engine speed is further raised up to a high engine speed region in which the engine speed is higher than in the low engine speed region, namely, when the engine is operated in a rapid acceleration state, the valve-forward pressure is further increased due to an increase in the flow of exhaust gas from the engine. Valve 2 is further rotationally moved away from position C and placed in the second open state. In the second open state, end peripheral surface 2d of valve 2 becomes out of contact with contact surface 8b of end valve guide 8 so that there is generated a clearance therebetween. Therefore, the exhaust sound from the engine is emitted from tail tube 26 to atmospheric air via both the first route and the second route. Thus, even when the flow of exhaust gas is increased, increase in pressure loss can be suppressed to thereby enhance the engine output in the high engine speed region.

[0058] Referring FIG. 5, there is shown a relationship between the engine speed and the opening of valve 2. As shown in FIG. 5, when the engine speed is in the engine starting region, valve 2 is placed in the first open state described above. Further, when the engine speed is increased to be in the idling region or the low engine speed region, valve 2 is brought into the closing state. When the engine speed reaches the high engine speed region, valve 2 is brought into the second open state as described above.

[0059] That is, in the exhaust sound controlling apparatus of the present invention, valve 2 is constructed to be operated corresponding to the engine speed. The spring force (spring constant) of torsion spring 5, the opening of valve 2 and the opening area of aperture 1a, 21a may be suitably set to operate valve 2 corresponding to the engine speed as described above. Alternatively, the valve-forward pressure (the exhaust pressure in second expansion chamber 23) may be suitably set to operate valve 2 corresponding to the engine speed.

[0060] FIG. 6 shows a relationship between the valve-forward pressure and the flow rate of exhaust gas. As shown in FIG. 6, the valve-forward pressure varies depending upon the flow rate of exhaust gas. Further, as shown in FIG. 6, as the engine speed becomes higher, the flow rate of exhaust gas is increased in the order of the idling region, the low engine speed region and the high engine speed region.

[0061] On the basis of the relationships as explained above, the construction of the exhaust sound controlling apparatus of the present invention is appropriately designed. For instance, the spring constant (the biasing force) of torsion spring 5 can be set such that valve 2 is rotationally moveable from position A to the position immediately before position B against the valve-forward pressure in the engine starting region, valve 2 is rotationally moveable from position B to position C against the valve-forward pressure in the idling region and the low engine speed region, and valve 2 is rotationally moveable beyond and away from position C in the high engine speed region, as shown in FIG. 3.

[0062] Owing to suitably setting the spring constant of torsion spring 5 as described above, the rotational movement of valve 2 from position B and position C can be ensured even when the flow of exhaust gas pulses in the idling region and the low engine speed region and the rotational movement of valve 2 pulses along with the pulse of the flow of exhaust gas. Valve 2, therefore, can be prevented from coming into contact with baffle plate 1, 21. As a result, when the engine is operated in the idling region and the low engine speed region, it is possible to suppress occurrence of striking noise which would be caused due to the contact of valve 2 with baffle plate 1, 21, and maintain a silence within the interior of the vehicle.

[0063] The exhaust sound controlling apparatus of the embodiment can perform the following function and effect. In the engine starting region, valve 2 is placed in the first open state in which exhaust gas emitted from the engine is permitted to pass through the communication passage in the second route B and thereby flow in the exhaust path via both the first route A and the second route B as shown in FIG. 4. As a result, powerful exhaust sound can be created. In the idling region and the low engine speed region, valve 2 is placed in the closing state in which the flow of exhaust gas is prevented from passing through the communication passage in the second route B and thereby allowed to flow in the exhaust path substantially only via the first route A. As a result, a silence within the interior of the vehicle can be ensured. In the high engine speed region, valve 2 is placed in the second open state in which the flow of exhaust gas is permitted to pass through the communication passage in the second route B and thereby flow in the exhaust path via both the first route A and the second route B, and the opening of valve 2 is increased as the engine speed becomes higher. Therefore, in the high engine speed region, even when an amount of the flow of exhaust gas is increased, increase in pressure loss can be suppressed.

[0064] Further, with the provision of the simple valve structure as described above, the exhaust sound control can be suitably performed depending on the engine speed as explained above. Further, the exhaust sound can be controlled by setting the spring constant (the biasing force) of torsion spring 5 as explained above.

[0065] Furthermore, curved end portion 2a of valve 2 serves as a gas leakage inhibiting portion that prevents the exhaust gas and the exhaust sound from leaking from curved end portion 2a toward the downstream side of baffle plate 1 during the rotational movement of valve 2. Valve 2 is supported at curved end portion 2a relative to baffle plate 1, and the outer circumferential surface of curved end portion 2a is substantially in contact (slide contact) with baffle plate 1 during the rotational movement of valve 2. Therefore, while valve 2 is rotationally moved, the exhaust gas and the exhaust sound can be prevented from leaking from curved end portion 2a toward the downstream side of baffle plate 1.

[0066] Referring to FIG. 7 to FIG. 9, a modification of the valve structure used in the exhaust sound controlling apparatus of the embodiment is explained. Similar to the valve structure as described above, the modified valve structure is constructed to prevent the exhaust gas from leaking from the support portion of valve 102 with respect to baffle plate 1. As shown in FIG. 7 and FIG. 8, valve 102 is a generally rectangular-shaped plate member and differs from valve 2 used in the embodiment in that a curved end portion is not formed. Valve 102 includes planar valve body 2c with one end portion 2e, and a pair of support portions 2b disposed on opposite sides of one end portion 2e. Valve shaft 4 extends through shaft insertion holes of support portions 2b and is supported by support portions 2b. Each of support portions 2b has an extension that extends around the shaft insertion hole, and is connected at the extension with one end portion 2e.

[0067] Gas leakage inhibiting member 11 is disposed on the downstream side surface of baffle plate 1 and located on a side of one end portion 2e of valve body 2c. Gas leakage inhibiting member 11 extends parallel to valve shaft 4 or one end portion 2e of valve body 2c, namely, an upper end periphery of valve 102 when viewed in FIG. 7 and FIG. 8. Gas leakage inhibiting member 11 is a bar member that has a generally L-shape in cross-section as shown in FIG. 8. Gas leakage inhibiting member 11 has one strip portion 11a that is mounted to baffle plate 1 and the other strip portion 11b that is disposed uprightly with respect to baffle plate 1. Specifically, the other strip portion 11b is inclined toward aperture 1a of baffle plate 1.

[0068] As shown in FIG. 9, when valve 102 is rotationally moved about valve shaft 4, a tip end of one end portion 2e of valve 102 is moved so as to draw a part of a circle that has a center on the axis of valve shaft 4. At this time, the tip end of one end portion 2e is moved on an outer surface of the other strip portion 11b of gas leakage inhibiting member 11 in contact with the outer surface of the other strip portion 11b.

[0069] During the rotational movement of valve 102, the exhaust gas and the exhaust sound can be prevented from leaking from one end portion 2e of valve 102 at which valve 102 is supported relative to baffle plate 1 through gas leakage inhibiting member 11, toward the downstream side of baffle plate 1. In view of this effect of gas leakage prevention, it is preferred that the other strip portion 11b of gas leakage inhibiting member 11 is curved in conformity with a locus of the tip end of one end portion 2e of valve 102 which is drawn during the rotational movement of valve 102.

[0070] Valve 102 has the same operating positions and operating states as those of valve 2 as shown in FIG. 3. That is, in the engine starting region, valve 102 is moveable from position A to a position immediately before position B as shown in FIG. 9. At this time, valve 102 is in the first open state in which the fluid communication between the upstream side expansion chamber on the upstream side of baffle plate 1 and the downstream side expansion chamber on the downstream side of baffle plate 1 through the communication passage therebetween is established. In the idling region and the low engine speed region, valve 102 is moved from position B to position C as shown in FIG. 9. At this time, valve 102 is in the closing state in which the fluid communication between the upstream side expansion chamber on the upstream side of baffle plate 1 and the downstream side expansion chamber on the downstream side of baffle plate 1 through the communication passage therebetween is blocked. In the high engine speed region, valve 102 is moved away from position C in the

opening direction. At this time, valve 102 is in the second open state in which the fluid communication between the upstream side expansion chamber on the upstream side of baffle plate 1 and the downstream side expansion chamber on the downstream side of baffle plate 1 through the communication passage therebetween is re-established.

[0071] Referring to FIG. 10, a modification of muffler 20 shown in FIG. 4 is explained. As shown in FIG. 10, modified muffler 40 includes first baffle plate 41 and second baffle plate 42 that extend within muffler 40 in a cross-sectional direction of muffler 40, namely, in a direction perpendicular to the flow of exhaust gas that passes through muffler 40. Baffle plates 41 and 42 are disposed within muffler 40 so as to divide the interior of muffler 40 into three expansion chambers adjacent to each other, namely, first expansion chamber 43, second expansion chamber 44 and third expansion chamber 45, which are located from the left side to the right side of muffler 40 in this order. First expansion chamber 43 and second expansion chamber 44 are separated from each other by baffle plate 41. Second expansion chamber 44 and third expansion chamber 45 are separated from each other by baffle plate 42. Second expansion chamber 44 is disposed between first expansion chamber 43 and third expansion chamber 45.

[0072] Inlet tube 46 extends into second expansion chamber 44 through an upstream end wall of muffler 40, first expansion chamber 43 and first baffle plate 41. Inlet tube 46 has one end that outwardly projects from the upstream end wall of muffler 40 and is connected to the engine through an exhaust pipe, not shown. Inlet tube 46 has the other end that is opened within second expansion chamber 44. Inlet tube 46 introduces the exhaust gas from the engine into second expansion chamber 44.

[0073] First pass-through tube 47 is disposed within muffler 40 coaxially with inlet tube 46. First pass-through tube 47 extends from second expansion chamber 44 into third expansion chamber 45 through second baffle plate 42 and communicates second expansion chamber 44 and third expansion chamber 45 with each other. First pass-through tube 47 has one end that is opened within second expansion chamber 44 and the other end that is opened within third expansion chamber 45 with each other. Second pass-through tube 48 extends through second baffle plate 42 in parallel with first pass-through tube 47. Second pass-through tube 48 has one end that is opened within third expansion chamber 45 and the other end that is connected with one side surface of first baffle plate 41 which is exposed to second expansion chamber 44.

[0074] First baffle plate 41 has generally rectangular-shaped aperture 41a. Second pass-through tube 48 is disposed coaxially with aperture 41a so as to communicate third expansion chamber 45 with aperture 41a. Third expansion chamber 45 and first expansion chamber 43 are communicated with each other through aperture 41a and second pass-through tube 48. The valve structure shown in FIG. 1 to FIG. 3 or the modified valve structure shown in FIG. 7 to FIG. 9 is provided on an opposite side surface of first baffle plate 41 which is exposed to first expansion chamber 43. That is, valve 2 or 102 is arranged on the opposite side surface of first baffle plate 41, namely, on a downstream side surface of first baffle plate 41 with respect to the flow of exhaust gas passing through second pass-through tube 48, such that valve body 2c covers aperture 41a except for opening 10. Valve 2 or 102, valve guides 6, 7 and 8 and first baffle plate 41 cooperate with each other to define a communication passage that allows fluid communication between first expansion chamber 43 and

third expansion chamber 45 through second pass-through tube 48. The communication passage includes opening 10 that is disposed between end peripheral surface 2d of valve 2 or 102 and an aperture-forming rim of first baffle plate 41 which defines the periphery of aperture 41a. The communication passage further includes the clearance that is formed between valve 2 or 102 and valve guides 6, 7 and 8 upon rotation of valve 2 or 102 about valve shaft 4.

[0075] First tail tube 49 extends from first expansion chamber 43 to an outside of muffler 40 through first baffle plate 41, second baffle plate 42, second expansion chamber 44, third expansion chamber 45 and a downstream end wall of muffler 40. First tail tube 49 has one end that is opened within first expansion chamber 43 and the other end that outwardly projects from the downstream end wall of muffler 40 and is exposed to atmospheric air. Second tail tube 50 extends from second expansion chamber 44 to the outside of muffler 40 through second baffle plate 42, third expansion chamber 45 and the downstream end wall of muffler 40. Second tail tube 50 has one end that is opened within second expansion chamber 44 and the other end that outwardly projects from the downstream end wall of muffler 40 and is exposed to atmospheric air. Each of expansion chambers 43, 44, 45 is larger in cross-sectional area than inlet tube 46, pass-through tubes 47, 48 and tail tubes 49, 50. In the construction of muffler 40, the exhaust path extends through first inlet tube 46, second expansion chamber 44, second tail tube 50, first pass-through tube 47, third expansion chamber 45, second pass-through tube 48, first expansion chamber 43, first tail tube 49 and the communication passage between first expansion chamber 43 and third expansion chamber 45.

[0076] In thus constructed muffler 40, exhaust sound generated from the engine is controlled depending on an operating condition of the engine. The exhaust sound is emitted to atmospheric air via a first route indicated by arrow A in FIG. 10, a second route indicated by arrow B in FIG. 10 or both the first route and the second route in accordance with the engine operating condition. The first route extends sequentially through inlet tube 46, second expansion chamber 44 and second tail tube 50. The second route extends sequentially through inlet tube 46, second expansion chamber 44, first pass-through tube 47, third expansion chamber 45, second pass-through tube 48, the communication passage between valve 2 or 102 and valve guides 6, 7 and 8, first expansion chamber 43 and first tail tube 49. The second route bypasses second tail tube 50.

[0077] Specifically, in the engine starting region, the exhaust sound from the engine is emitted from second tail tube 50 to atmospheric air via the first route indicated by arrow A in FIG. 10. Further, in the engine starting region, valve 2 or 102 is moveable from position A to a position immediately before position B as shown in FIG. 9. At this time, valve 2 or 102 is placed in the first open state in which the communication passage including opening 10 and the clearance between end peripheral surface 2d of valve 2 or 102 and clearance forming surface 8a of end valve guide 8 is opened so that the second route indicated by arrow B in FIG. 10 is permitted. Therefore, exhaust sound from the engine is also emitted from first tail tube 49 to atmospheric air via the second route. Since the emission of the exhaust sound is thus performed via both the first route and the second route, the exhaust sound in the engine starting region can be enhanced as compared to the conventional exhaust sound controlling apparatus.

[0078] Further, when the engine speed is raised up to the idling region, valve 2 or 102 is rotationally moved to position B shown in FIG. 9 due to an increase in the valve-forward pressure. Valve 2 or 102 is placed in the closing state in which end peripheral surface 2d is substantially contacted with contact surface 8b of end valve guide 8. Therefore, the exhaust sound from the engine is prevented from being emitted from tail tube 49 to atmospheric air via the second route indicated by arrow B in FIG. 10 and can be emitted from tail tube 50 to atmospheric air substantially only via the first route indicated by arrow A in FIG. 10. As a result, the exhaust sound that is emitted from muffler 40 to atmospheric air can be reduced.

[0079] When the engine speed is further raised up to the low engine speed region and maintained in the low engine speed region, the valve-forward pressure is further increased with raising of the engine speed. Due to the increase in the valve-forward pressure, valve 2 or 102 is rotationally moved from position B to position C shown in FIG. 9. During the rotational movement from position B to position C, valve 2 or 102 is kept in the closing state. Therefore, the emission of the exhaust sound substantially only via the first route indicated by arrow A in FIG. 10 is maintained so that the exhaust sound from the engine can be kept reduced.

[0080] Further, when the engine speed is raised up to the high engine speed region, the valve-forward pressure is further increased due to an increase in the flow of exhaust gas from the engine. Valve 2 or 102 is further rotationally moved away from position C shown in FIG. 9 and placed in the second open state. In the second open state, end peripheral surface 2d of valve 2 or 102 becomes out of contact with contact surface 8b of end valve guide 8 and there is generated a clearance therebetween. Therefore, the exhaust sound from the engine is emitted from both tail tubes 49 and 50 to atmospheric air via both the first route indicated by arrow A in FIG. 10 and the second route indicated by arrow B in FIG. 10. Thus, in the high engine speed region, even when the flow of exhaust gas is increased, increase in pressure loss can be suppressed to thereby enhance the engine output.

[0081] Next, a method for controlling exhaust sound from the engine which is emitted through the exhaust path, of the embodiment is explained. The method includes a first control step of reducing a flow rate of exhaust gas that passes through the exhaust path, to a first flow rate in accordance with increase in engine speed in a first engine speed region, and a second control step of increasing the flow rate of exhaust gas to a second flow rate in accordance with increase in engine speed in a second engine speed region in which the engine speed is higher than the engine speed in the first engine speed region. The method further includes a third control step of reducing the flow rate of exhaust gas to a third flow rate that is lower than the first flow rate and the second flow rate in a third engine speed region between the first engine speed region and the second engine speed region. The engine speed in the first engine speed region includes an engine speed in an engine starting region. The engine speed in the second engine speed region includes an engine speed in a high engine speed region. The engine speed in the third engine speed region includes an engine speed in an idling region and an engine speed in a low engine speed region.

[0082] The method for controlling exhaust sound can perform the following effects. In the engine starting region, exhaust gas emitted from the engine is permitted to pass through the exhaust path so that powerful exhaust sound can be created. In the idling region and the low engine speed

region, the flow of exhaust gas is reduced so that a silence within the interior of the vehicle can be ensured. In the high engine speed region, the flow of exhaust gas is permitted to pass through the exhaust path and the flow rate of exhaust gas is increased as the engine speed becomes higher. As a result, increase in pressure loss can be suppressed.

**[0083]** This application is based on prior Japanese Patent Application No. 2007-098526 filed on Apr. 4, 2007. The entire contents of the Japanese Patent Application No. 2007-098526 are hereby incorporated by reference.

**[0084]** Although the invention has been described above by reference to a certain embodiment of the invention and modifications of the embodiment, the invention is not limited to the embodiment and the modifications described above. Variations of the embodiment and the modifications described above will occur to those skilled in the art in light of the above teachings. The scope of the invention is defined with reference to the following claims.

What is claimed is:

1. A method for controlling exhaust sound from an engine which is emitted through an exhaust path, the method comprising:

a first control step of reducing a flow rate of exhaust gas that passes through the exhaust path, to a first flow rate in accordance with increase in engine speed in a first engine speed region; and

a second control step of increasing the flow rate of exhaust gas to a second flow rate in accordance with increase in engine speed in a second engine speed region in which the engine speed is higher than that in the first engine speed region.

2. The method as claimed in claim 1, further comprising a third control step of reducing the flow rate of exhaust gas to a third flow rate that is lower than the first flow rate and the second flow rate in a third engine speed region between the first engine speed region and the second engine speed region.

3. The method as claimed in claim 1, wherein the engine speed in the first engine speed region comprises an engine speed in an engine starting region.

4. The method as claimed in claim 1, wherein the engine speed in the second engine speed region comprises an engine speed in a high engine speed region.

5. The method as claimed in claim 2, wherein the engine speed in the third engine speed region comprises an engine speed in an idling region.

6. The method as claimed in claim 2, wherein the engine speed in the third engine speed region comprises an engine speed in a low engine speed region.

7. An apparatus for controlling exhaust sound from an engine which is emitted through an exhaust path, the apparatus comprising:

a baffle plate that is disposed within the exhaust path so as to block a flow of exhaust gas in the exhaust path, the baffle plate being formed with an aperture;

a communication passage that communicates an upstream side of the baffle plate and a downstream side of the baffle plate with each other;

a valve that is so disposed as to cover a part of the aperture of the baffle plate and operated to open and close the communication passage; and

wherein the valve is operated to open the communication passage in an engine starting region, the valve is operated to close the communication passage in an idling region and a low engine speed region, and the valve is

operated to open the communication passage and increase an opening of the valve as the engine speed rises in a high engine speed region.

8. The apparatus as claimed in claim 7, further comprising a means for cooperating with the valve to define the communication passage during the rotational movement of the valve.

9. The apparatus as claimed in claim 7, further comprising a biasing means for biasing the valve toward the baffle plate.

10. An apparatus for controlling exhaust sound from an engine which is emitted through an exhaust path, the apparatus comprising:

a baffle plate that is disposed within the exhaust path so as to block a flow of exhaust gas in the exhaust path, the baffle plate being formed with an aperture;

a valve that is so disposed as to cover a part of the aperture of the baffle plate, the valve being rotationally moveable relative to the baffle plate so as to be apart from the baffle plate in a direction of the flow of exhaust gas,

a biasing means for biasing the valve toward the baffle plate; and

an enclosure member that extends from the baffle plate so as to be opposed to the outer periphery of the valve when the valve is moved relative to the baffle plate,

wherein the valve has a contact position in which the valve is contacted with the baffle plate and covers the part of the aperture of the baffle plate, a small distance position in which the valve is apart from the baffle plate in the direction of the flow of exhaust gas with a first distance therebetween, an intermediate distance position in which the valve is apart from the baffle plate in the direction of the flow of exhaust gas with a second distance therebetween which is larger than the first distance, and a large distance position in which the valve is apart from the baffle plate in the direction of the flow of exhaust gas with a third distance therebetween which is larger than the first distance and the second distance, and

wherein when the valve is placed in the contact position, the valve cooperates with the baffle plate to define an opening between the outer periphery of the valve and a periphery of the aperture of the baffle plate,

when the valve is placed in the small distance position, the valve cooperates with the enclosure member to define a first clearance between the outer periphery of the valve and an opposing surface of the enclosure member that is opposed to the outer periphery of the valve,

when the valve is placed in the intermediate distance position, at least a part of the outer periphery of the valve is substantially contacted with the opposing surface of the enclosure member, and

when the valve is placed in the large distance position, the valve cooperates with the enclosure member to define a second clearance between the outer periphery of the valve and the opposing surface of the enclosure member, and the second clearance is increased as the third distance between the valve and the baffle plate becomes larger.

11. The apparatus as claimed in claim 10, wherein the biasing means has a biasing force that acts on the valve against a pressure of the exhaust gas that flows in the exhaust path, the biasing force urges the valve to move to the small distance position in an engine starting region, the biasing force urges the valve to move to the intermediate distance position in an idling region and a low engine speed region,

and the biasing force urges the valve to move to the large distance position in a high engine speed region.

**12.** The apparatus as claimed in claim **10**, wherein the valve comprises a gas leakage inhibiting portion that prevents the exhaust gas and the exhaust sound from leaking from a support portion of the valve at which the valve is supported relative to the baffle plate, toward a downstream side of the baffle plate during the rotational movement of the valve.

**13.** The apparatus as claimed in claim **10**, further comprising a gas leakage inhibiting member that prevents the exhaust gas and the exhaust sound from leaking from a support portion of the valve at which the valve is supported relative to the baffle plate, toward a downstream side of the baffle plate during the rotational movement of the valve.

**14.** The apparatus as claimed in claim **10**, further comprising a first expansion chamber, a second expansion chamber that are separated from the first expansion chamber by the baffle plate, a first communication tube having one end that is connected to the engine and the other end that is opened within the second expansion chamber, a second communication tube having one end that is exposed to atmospheric air and the other end that is opened within the first expansion chamber, and a third communication tube that extends through the baffle plate and communicates the first expansion chamber and the second expansion chamber with each other,

wherein the first and second expansion chambers are larger in sectional area than the first, second and third communication tubes.

**15.** The apparatus as claimed in claim **10**, further comprising a first expansion chamber, a second expansion chamber that is separated from the first expansion chamber by the baffle plate, a third expansion chamber, a second baffle plate that separates the third expansion chamber and the second expansion chamber from each other, an inlet tube having one end that is connected to the engine and the other end that is opened within the second expansion chamber, a first tail tube having one end that is exposed to atmospheric air and the other end that is opened within the first expansion chamber, a second tail tube having one end that is exposed to atmospheric air and the other end that is opened within the second expansion chamber, a first pass-through tube that extends through the second baffle plate and communicates the second expansion chamber with the third expansion chamber, and a second pass-through tube that extends through the second baffle plate and communicates the third expansion chamber with the aperture of the baffle plate, wherein the first, second and third expansion chambers being larger in sectional area than the inlet tube, the first and second tail tubes and the first and second pass-through tubes.

\* \* \* \* \*