



US006871138B1

(12) **United States Patent**
Minelli

(10) **Patent No.:** **US 6,871,138 B1**
(45) **Date of Patent:** **Mar. 22, 2005**

(54) **RUGGED, WATERPROOF, NAVIGATION DEVICE WITH TOUCH PANEL**

(75) Inventor: **Jeffrey D. Minelli**, Olathe, KS (US)

(73) Assignee: **Garmin Ltd.** (KY)

(*) Notice: Subject to any disclaimer, the term of this patent is extended or adjusted under 35 U.S.C. 154(b) by 0 days.

(21) Appl. No.: **10/792,104**

(22) Filed: **Mar. 3, 2004**

Related U.S. Application Data

(63) Continuation of application No. 10/185,604, filed on Jun. 28, 2002, now Pat. No. 6,721,651.

(51) **Int. Cl.**⁷ **G01C 21/26**

(52) **U.S. Cl.** **701/200**; 345/173; 345/104; 345/3.1; 156/66; 156/99; 361/681; 361/683; 349/60; 174/50.51; 174/50.54; 174/35 GC

(58) **Field of Search** 701/200; 345/173, 345/104, 3.1; 156/66, 99; 361/681, 683; 349/60; 174/50.51, 50.54, 35 GC

(56) **References Cited**

U.S. PATENT DOCUMENTS

4,811,613 A	3/1989	Phillips et al.	74/5.6 D
4,831,563 A	5/1989	Ando et al.	364/571.05
4,924,402 A	5/1990	Ando et al.	364/449
5,149,919 A *	9/1992	Greanias et al.	178/18.02
5,220,509 A	6/1993	Takemura et al.	364/449
5,331,563 A	7/1994	Masumoto et al.	342/457
5,349,530 A	9/1994	Odagawa	364/449
5,363,306 A	11/1994	Kuwahara et al.	364/449

5,396,430 A	3/1995	Arakawa et al.	364/449
5,424,953 A	6/1995	Masumoto et al.	364/449
5,506,774 A	4/1996	Nobe et al.	364/424.05
5,657,231 A	8/1997	Nobe et al.	364/449.3
5,742,925 A	4/1998	Baba	701/221
5,852,791 A	12/1998	Sato et al.	701/217
5,862,511 A	1/1999	Croyle et al.	701/213
5,890,092 A	3/1999	Kato et al.	701/216
6,067,133 A *	5/2000	Niibori et al.	349/60
6,353,798 B1	3/2002	Green et al.	701/213
6,356,259 B1 *	3/2002	Maeda et al.	345/173
6,374,177 B1	4/2002	Lee et al.	701/200
6,374,179 B1	4/2002	Smith et al.	701/207
6,507,337 B1 *	1/2003	Sato et al.	345/173
6,532,152 B1 *	3/2003	White et al.	361/692
6,538,880 B1 *	3/2003	Kamijo et al.	361/686
6,542,824 B1 *	4/2003	Berstis	701/220
2002/0011951 A1 *	1/2002	Pepin et al.	342/357.13
2002/0151994 A1 *	10/2002	Sisco	700/91
2002/0152025 A1 *	10/2002	Shimada	701/209

* cited by examiner

Primary Examiner—Thomas G. Black

Assistant Examiner—Ronnie Mancho

(74) *Attorney, Agent, or Firm*—Devon A. Rolf

(57) **ABSTRACT**

An electronic device includes a housing, a processor located within the housing and a memory in communication with the processor. The electronic device includes a display in communication with the processor and a touch panel positioned on a surface of the housing. The display is viewable through a touch panel mounted to an opening in the housing. The housing includes a flange around the opening which has a fluid seal to prevent fluid flow past the touch panel and into the housing. A shock mount may also be included within the housing to make the touch panel drop-resistant.

28 Claims, 14 Drawing Sheets

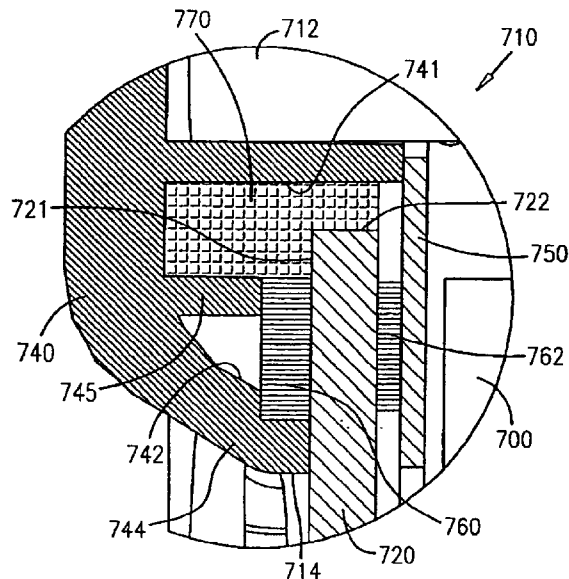

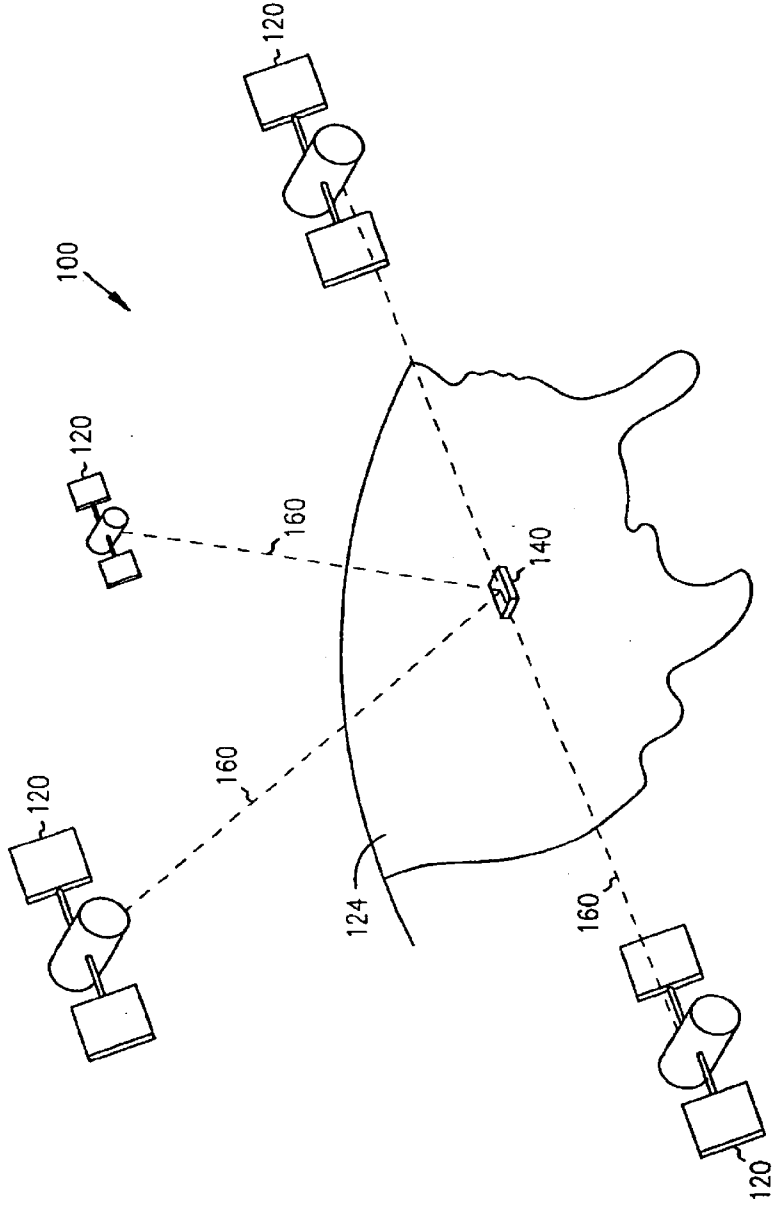

FIG. 1

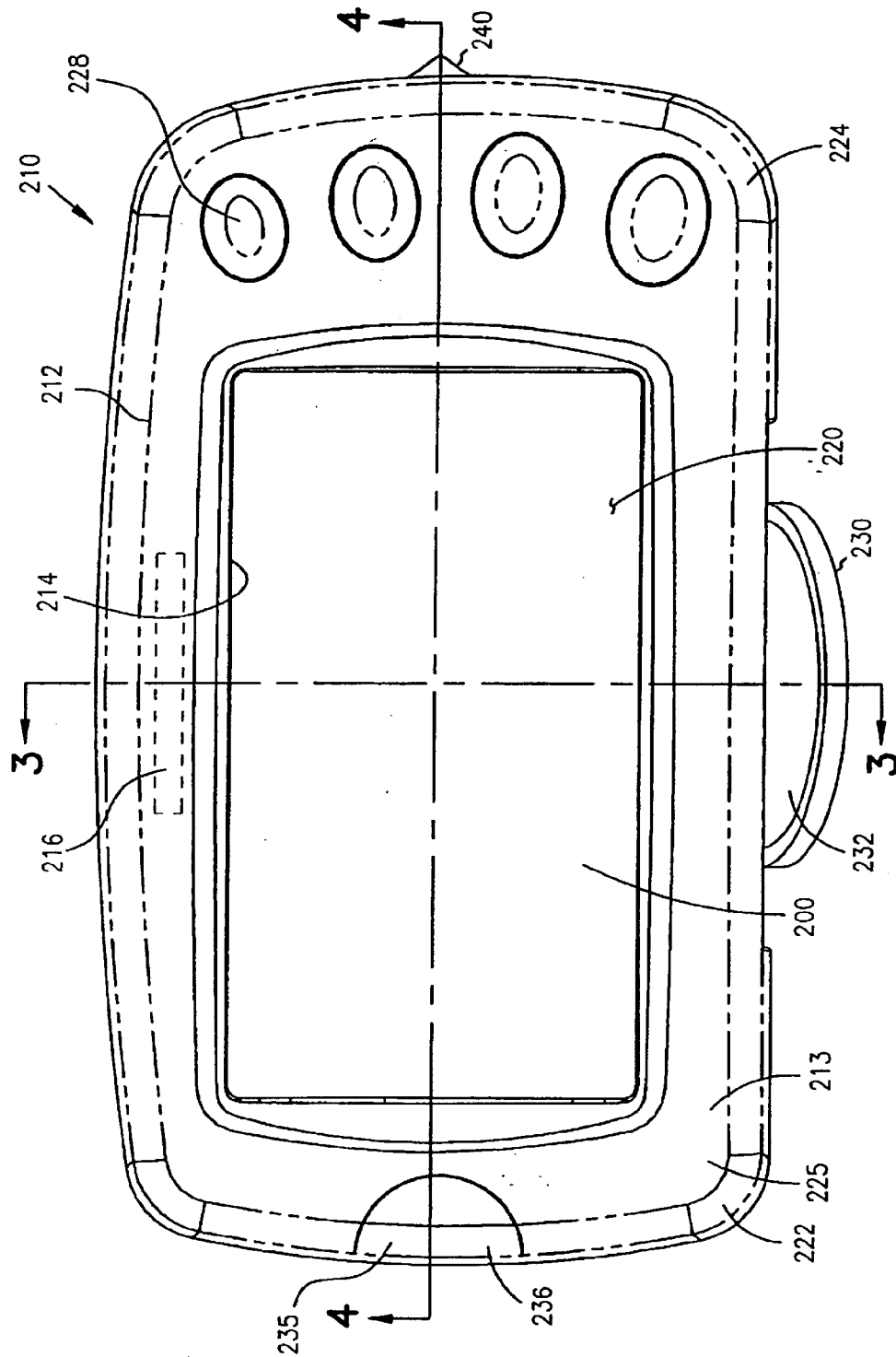

FIG. 2A

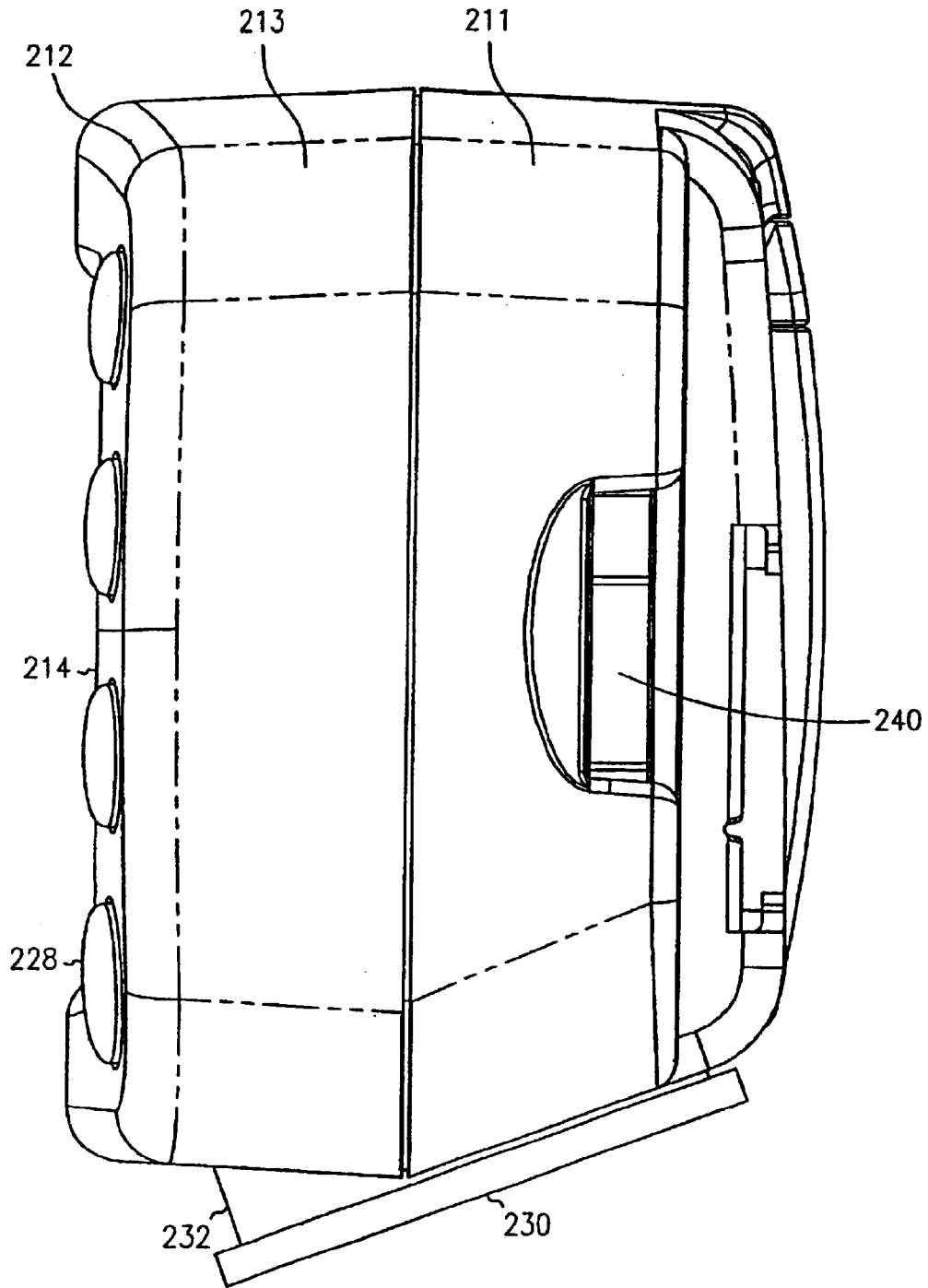

FIG. 2B

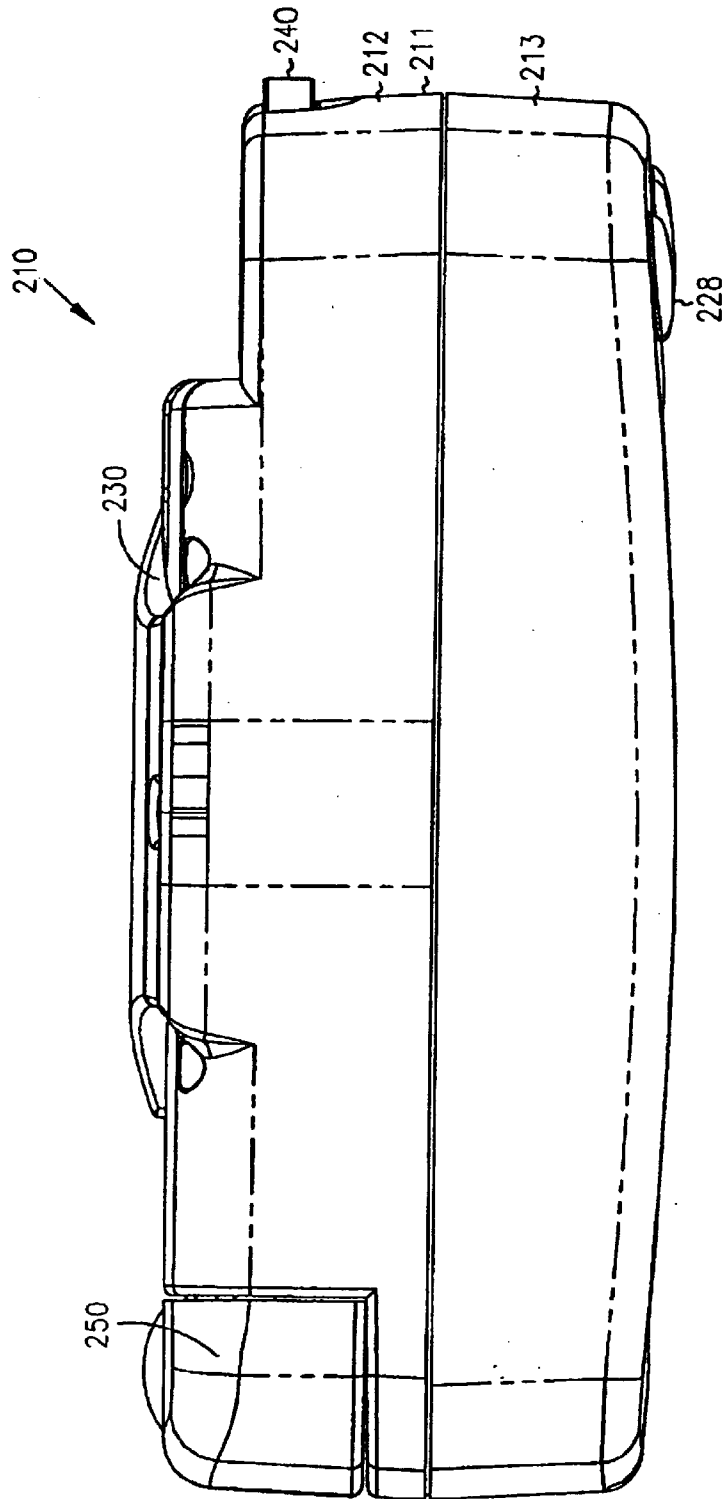

FIG. 2C

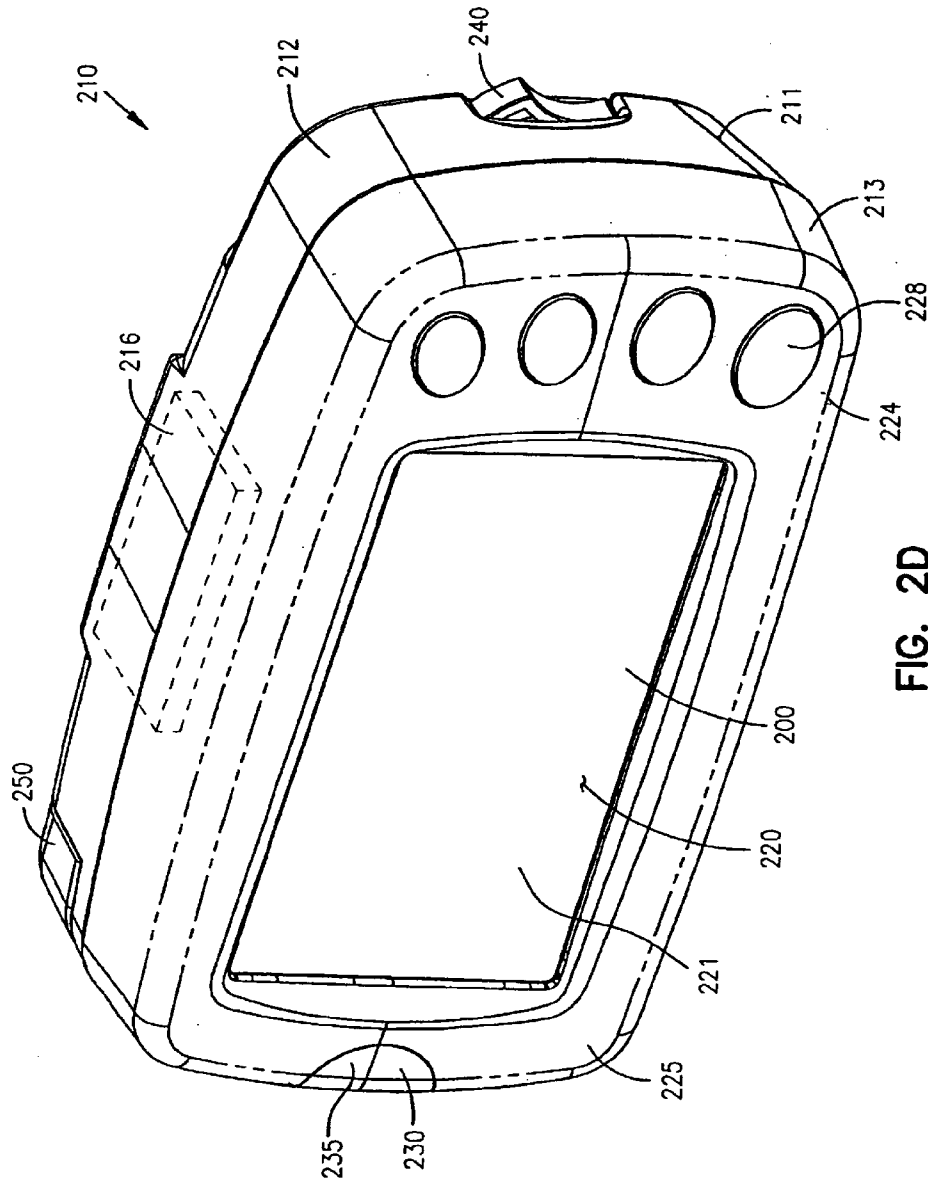

FIG. 2D

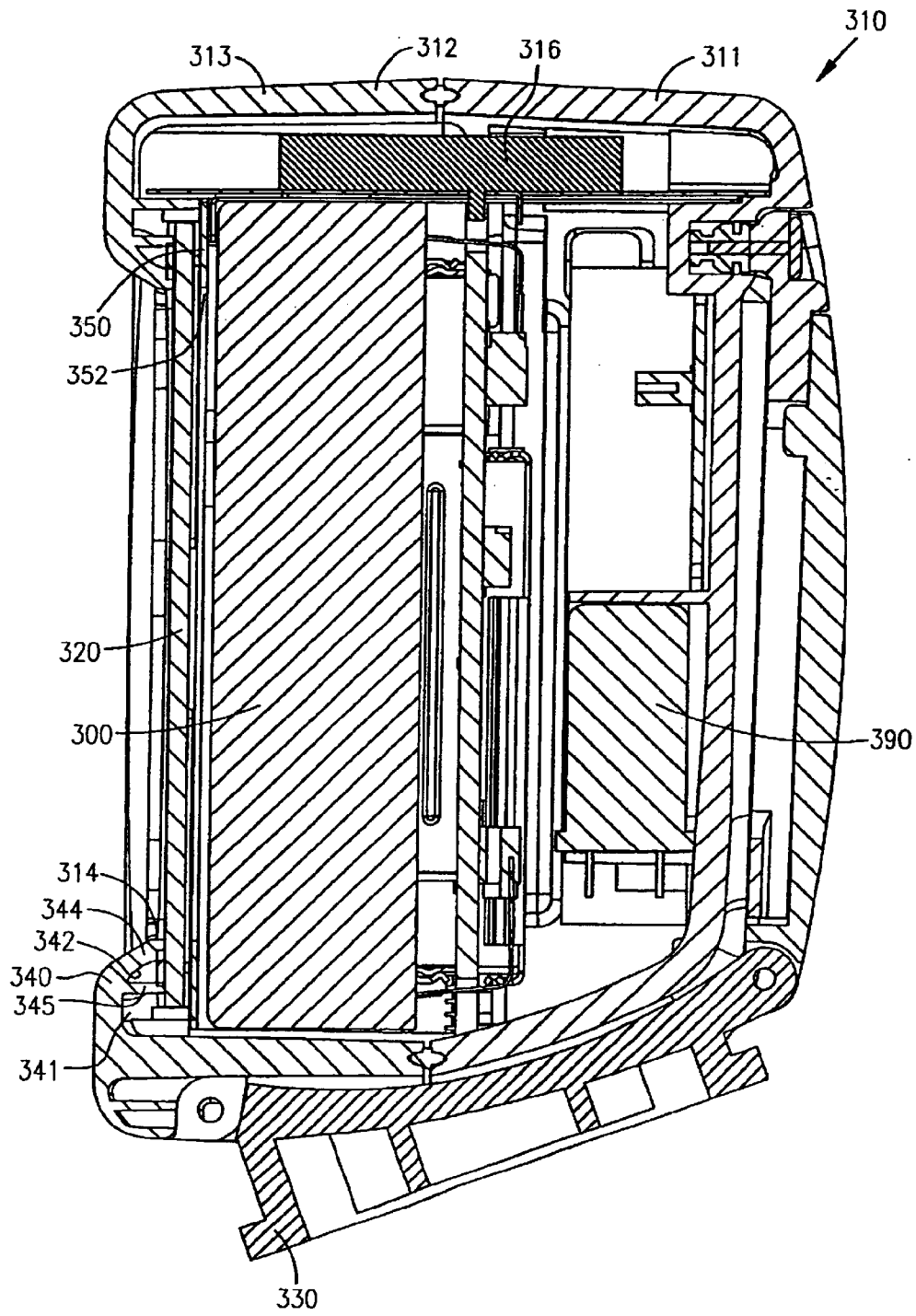

FIG. 3

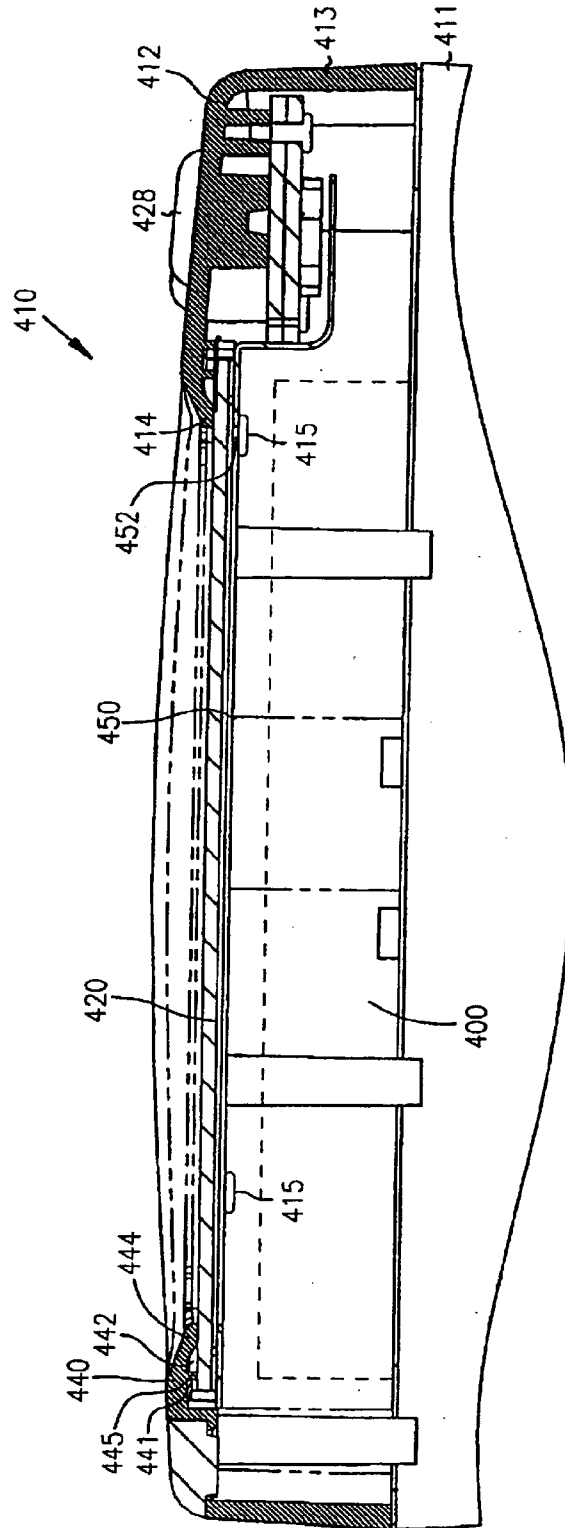

FIG. 4

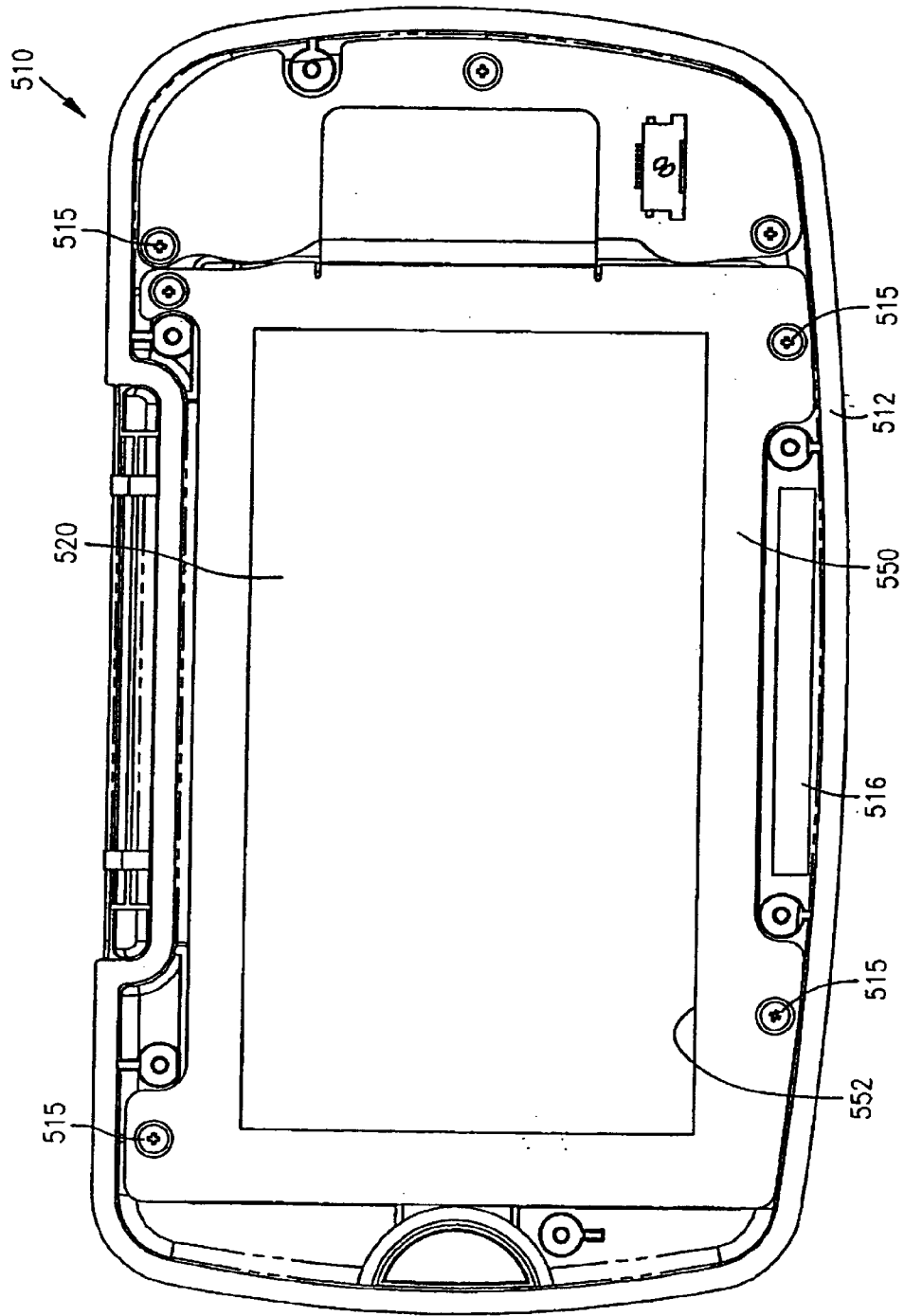

FIG. 5

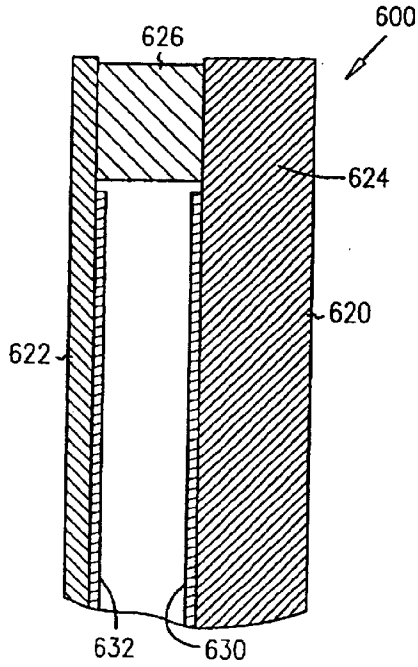

FIG. 6

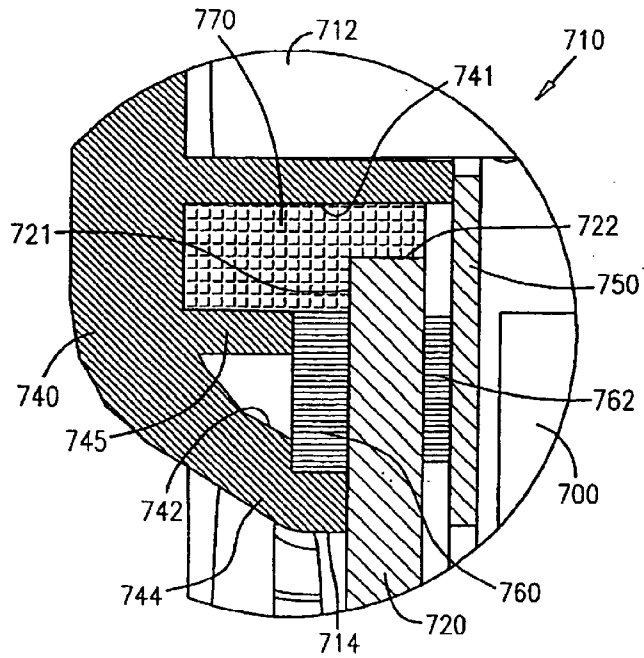

FIG. 7

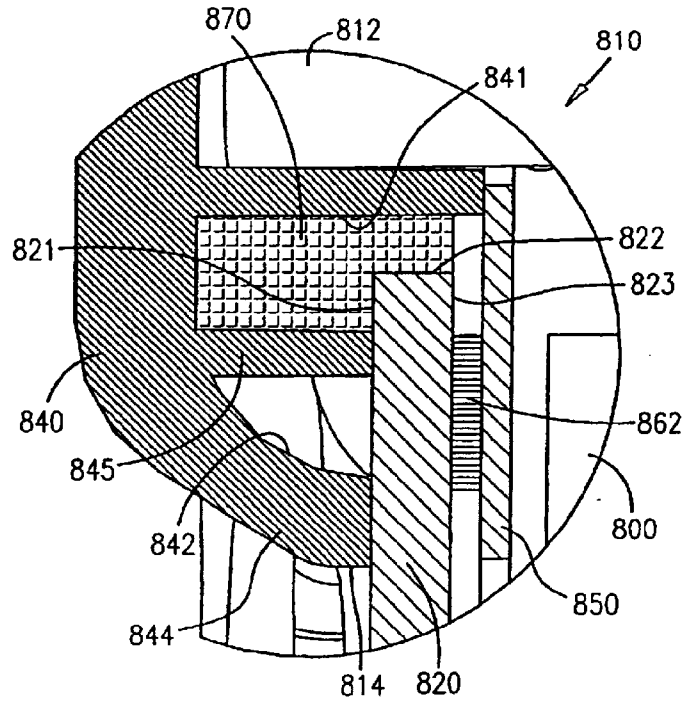

FIG. 8

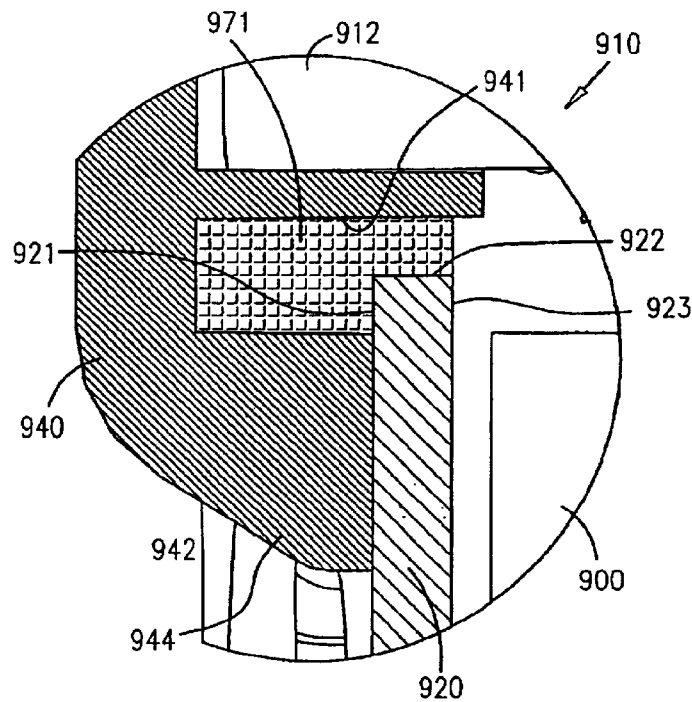

FIG. 9

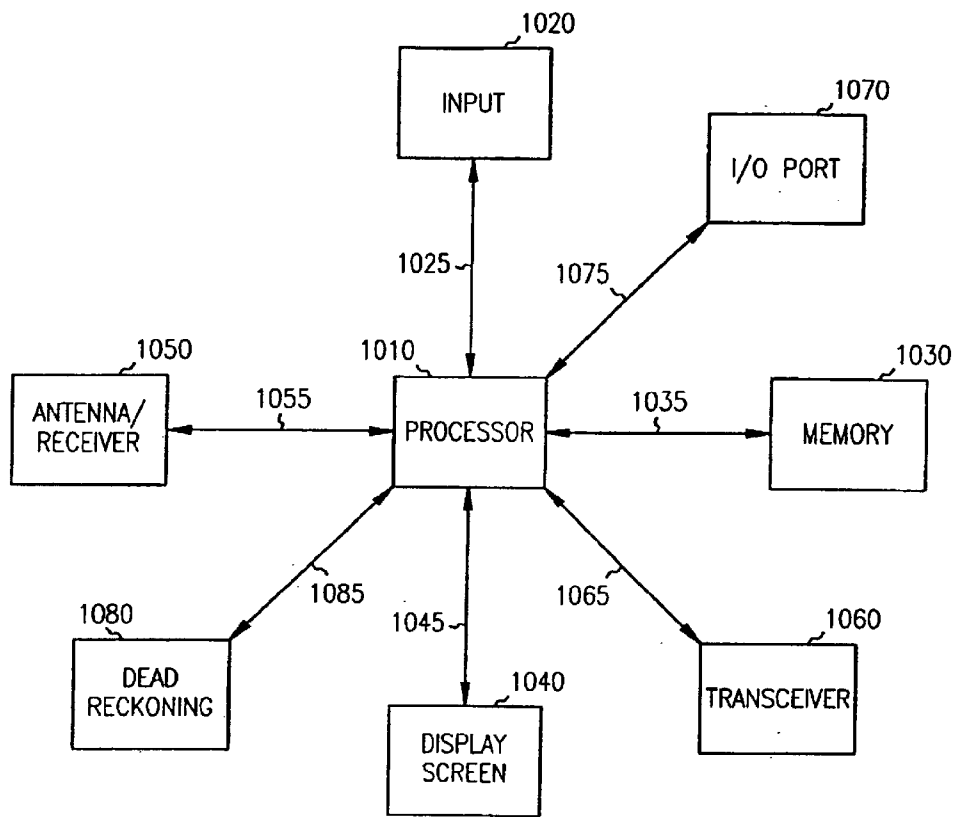

FIG. 10

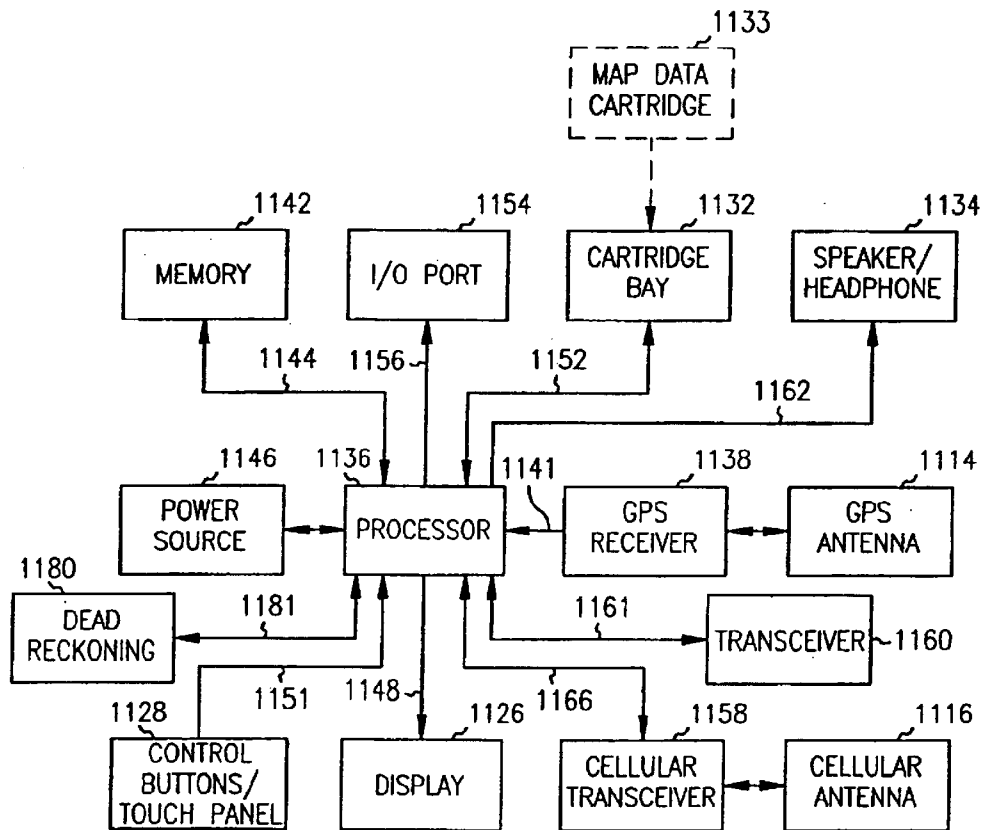

FIG. 11

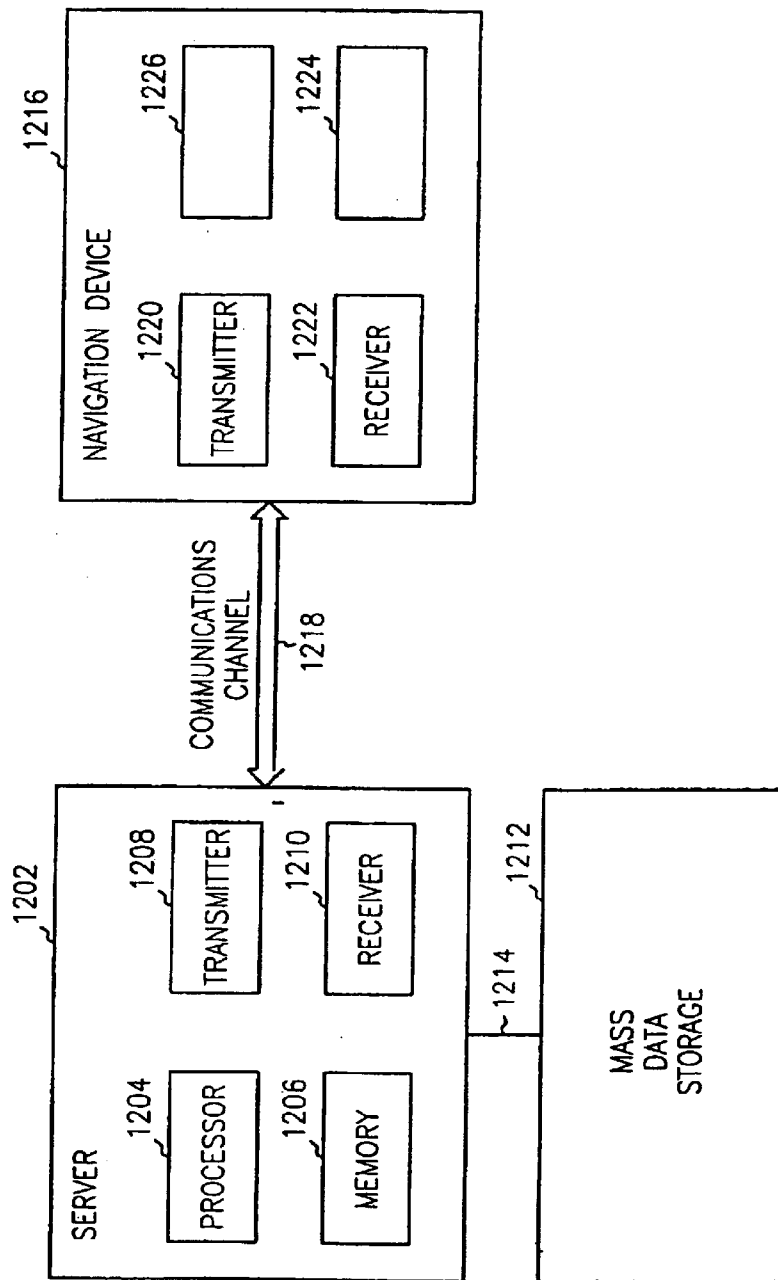

FIG. 12

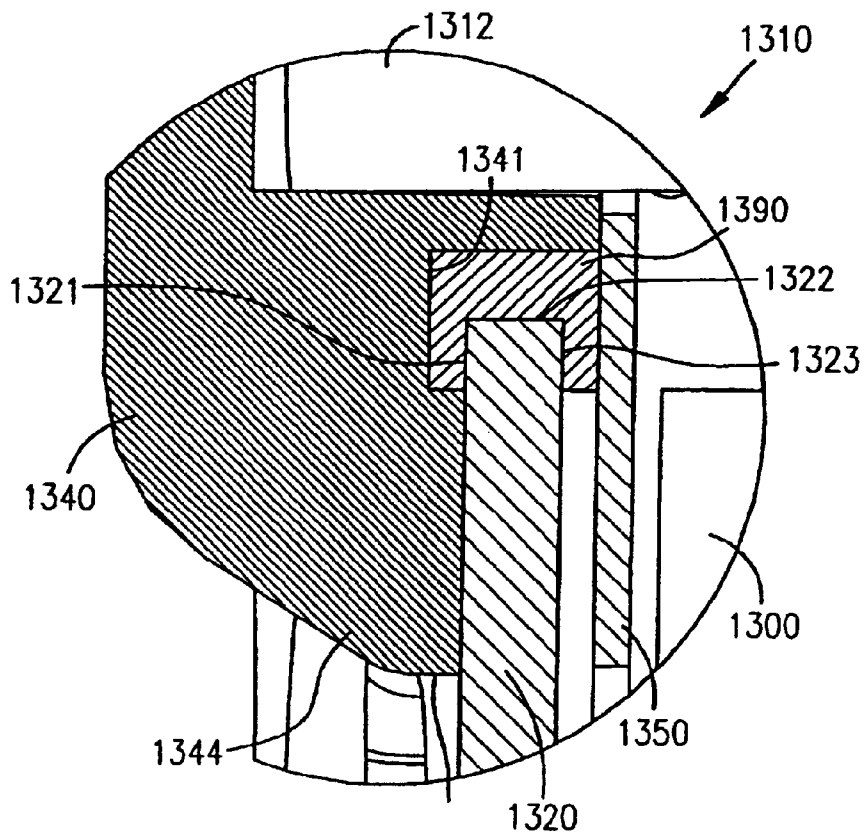

FIG. 13

1

RUGGED, WATERPROOF, NAVIGATION DEVICE WITH TOUCH PANEL

RELATED APPLICATIONS

The present application is a Continuation of and claims
priority benefit of U.S. patent Application Ser. No. 10/185,
604, filed Jun. 28, 2002, titled "RUGGED, WATERPROOF,
NAVIGATION DEVICE WITH TOUCH PANEL", now
U.S. Pat. No. 6,721,651, which is incorporated herein by
reference.

FIELD OF THE INVENTION

The present invention relates generally to navigational
devices, and in particular to navigational devices which are
both waterproofed and ruggedized.

BACKGROUND OF THE INVENTION

A natural progression in devices is to build more function
or even to combine more functions into one device. In the
past ten years, for example, mobile communications, personal
data assistants, and portable navigational devices have
become very popular. These devices have moved from
desktop computers to hand-held devices. Personal data
assistants ("PDA") are also exceedingly popular. The first
PDA-type devices merely held a listing of contacts and may
have had a calendar function. Now PDAs, in addition to
holding contact data and a calendar, hold e-mail. PDAs have
now been provided with the capability to respond to e-mail
and are linked or synchronized with a computer periodically
so any e-mail answers can be ported over to a computer for
sending. Calendar changes are also synchronized.

Navigational devices represent yet another technology
that has boomed as of late and which is now becoming
popular and affordable. Previously, navigational devices
were expensive and far from portable or hand-held. Most
navigational devices could only be found on ships and
airplanes. Now, navigational devices are popular options in
luxury cars and navigational devices have become popular
with outdoorsman of all types. Fisherman have them to mark
out their favorite fishing holes, for example. These devices
have also been combined with other devices, such as depth
finders or fish finders which are popular with anglers.

Recently, PDAs and navigational devices, such as global
positioning systems ("GPS"), have been combined. There
are problems with such combined devices. For example,
current combination devices which include a PDA and a
GPS are confusing to use. One of the more confusing aspects
is switching between the software applications needed for
the GPS and the software applications needed for the PDA.

When navigational devices or PDAs were first introduced,
problems associated with using these device outdoors were
generally not contemplated. The cost and size of the navigational
device all but prohibited one from using the navigational
device outdoors. PDAs were generally used in
office environments. Escaping to the outdoors generally
meant leaving your PDA inside. Such devices were not
waterproofed and not ruggedized.

The size reduction and lesser cost of the navigational
devices and the combination navigational devices and PDAs
now make outdoor use more common. As a result, the device
must be ruggedized to accommodate outdoor use. The
navigational device must be made waterproof as well as
drop-resistant so that the device can withstand the rigors
associated with such use. A device that combines uses, such
as a combination PDA and navigational device, must also be

2

made waterproof and drop-resistant. Making these devices
waterproof and drop-resistant also is necessary as many
users do not exercise care when handling such devices. It
seems that as the cost goes down, so does the amount of care
one uses in handling a device. Making such a device
waterproof and drop-resistant will lessen the number of
returns from users in the field. In addition, more rugged
devices generally will have a market advantage. A consumer
is more likely to pay a premium for a rugged, more depend-
able device.

SUMMARY OF THE INVENTION

An electronic device includes a housing, a processor
located within the housing and a memory in communication
with the processor. The electronic device includes a display
in communication with the processor and positioned on a
surface of the housing. The display is viewable through a
touch panel mounted to an opening in the housing. The
housing includes a flange around the opening which has a
fluid seal to prevent fluid flow past the touch panel and into
the housing. A shock mount may also be included within the
housing to make the touch panel drop-resistant. The elec-
tronic device includes a navigational component having an
instruction set for controlling the processor and memory to
perform a route calculation. The electronic device may also
communicate with a mass storage device adapted to store
navigation data and a server adapted to communicate with
the mass storage. The electronic device may also be multi-
functional and, in some embodiments, includes cell phone or
PDA capabilities.

A typical touch panel, in a hand-held electronic device,
has a rigid material layer and a flexible layer. The rigid
material layer and flexible material layer are held together in
spaced relation by a gasket of double adhesive tape. A major
surface of the rigid material and a major surface of the
flexible material are provided with an electrically conductive
film so that when the flexible material is deflected to touch
the rigid material a closed circuit indicating the location of
the contact is formed. A mounting member circumscribes
the opening in the housing. The mounting member has a
pocket for holding an adhesive. The adhesive is applied
about the periphery of the touch panel. In one embodiment
the adhesive is a flexible adhesive. In other embodiments the
adhesive is rigid. Either adhesive may be curable using an
ultraviolet light. In some embodiments, the hand-held elec-
tronic device is provided with a shock absorbing member,
such as a layer foam or other viscoelastic material. In still
other embodiments, the device includes a backing member
that fits within the housing. The backing member has a
portion positioned near the layer of rigid material of the
touch panel. The shock absorbing member includes a portion
which is sandwiched between the backing member and the
layer of rigid material of the touch panel. In some
embodiments, the shock absorbing member also includes a
portion which is sandwiched between the flexible member of
the touch panel and the mounting member. The mounting
member is molded with or integral with the housing. In still
other embodiments, a fluid seal is also provided. The fluid
seal can include a gasket.

The hand-held electronic device includes a navigational
component. The hand-held electronic device includes a
processor located within the housing, and a memory in
communication with the processor. The touch panel is in
communication with the processor and the memory. The
processor and memory is capable of performing a route
calculation viewable on the display. The shock mount
includes viscoelastic material which serves as a shock
absorbing member.

3

The portable, hand-held device may also be part of a navigation system which includes a mass storage device adapted to store navigation data, a server adapted to communicate with the mass storage, and the electronic device. The device includes an antenna within the housing for communicating with the server. The antenna is situated on the top portion of the housing. The electronic device includes a navigation device adapted to perform a route calculation based on instructions from an instruction set for controlling the processor and memory to perform the route calculation. At least a portion of the instruction set resides within the processor and memory. In some embodiments, a portion of the instruction set is transmitted to the portable, multi-function electronic device from the server. In some embodiments, the link is an optoelectrical communication link.

Advantageously, the invention provides for a device which can now be used outdoors. Even though all uses will not be outdoors, all users will benefit by having a more dependable, rugged device. The navigational device is waterproof. The touch panel and more specifically, the rigid portion of the touch panel, typically made of glass or plastic is more drop-resistant so that the device can withstand the rigors associated with outdoor use. Since the devices are waterproof and drop-resistant, the consumer market will perceive the device as more rugged and reliable and consumers will be more likely to pay a premium for the device. The number of returns from users in the field will also be less since the device is waterproof and drop-resistant.

These and other embodiments, aspects, advantages, and features of the present invention will be set forth in part in the description which follows, and in part will become apparent to those skilled in the art by reference to the following description of the invention and referenced drawings or by practice of the invention. The aspects, advantages, and features of the invention are realized and attained by means of the instrumentalities, procedures, and combinations particularly pointed out in the appended claims.

BRIEF DESCRIPTION OF THE DRAWINGS

FIG. 1 is a representative view of a Global Positioning System (GPS);

FIG. 2A illustrates a front view of an embodiment of a hand-held, electronic device that includes a navigation component;

FIG. 2B illustrates a end of the embodiment of a hand-held, electronic device shown in FIG. 2A;

FIG. 2C illustrates a top view of an embodiment of a hand-held, electronic device shown in FIG. 2A;

FIG. 2D illustrates a isometric view of an embodiment of a hand-held, electronic device shown in FIGS. 2A-2C;

FIG. 3 illustrates a cross-section view along line 3-3 in FIG. 2 of the hand-held, electronic device;

FIG. 4 illustrates a cross-section view along line 4-4 in FIG. 2 of the hand-held, electronic device;

FIG. 5 is a front cut away view of the hand-held, electronic device shown in FIGS. 2-4;

FIG. 6 is a cross-sectional view of a portion of the touch panel of the handheld, electronic device;

FIG. 7 is a cross-sectional view of the portion of the housing near the opening which details an embodiment for mounting the touch panel with respect to the housing of the hand-held, electronic device;

FIG. 8 is a cross-sectional view of the portion of the housing near the opening which details another embodiment

4

for mounting the touch panel with respect to the housing of the hand-held, electronic device;

FIG. 9 is a cross-sectional view of the portion of the housing near the opening which details yet another embodiment for mounting the touch panel with respect to the housing of the hand-held, electronic device;

FIG. 10 is a block diagram of one embodiment for the electronic components within the hardware of FIGS. 2A-2D according to the teachings of the present invention;

FIG. 11 is a block diagram of another embodiment for the electronic components within the hardware of FIGS. 2A-2D according to the teachings of the present invention;

FIG. 12 is a block diagram of a navigation system according to the teachings of the present invention;

FIG. 13 is a cross-sectional view of the portion of the housing near the opening which details yet another embodiment for mounting the touch panel with respect to the housing of the hand-held, electronic device;

DETAILED DESCRIPTION OF THE INVENTION

In the following detailed description of the invention, reference is made to the accompanying drawings which form a part hereof, and in which is shown, by way of illustration, specific embodiments in which the invention can be practiced. The embodiments are intended to describe aspects of the invention in sufficient detail to enable those skilled in the art to practice the invention. Other embodiments can be utilized and changes can be made without departing from the scope of the present invention. The following detailed description is, therefore, not to be taken in a limiting sense, and the scope of the present invention is defined only by the appended claims, along with the full scope of equivalents to which such claims are entitled.

The following description and figures use a reference numeral convention where the first digit of the reference numeral corresponds to the figure and the following two digits correspond to like elements throughout the specification. For example, the housing of a portable, hand-held, electronic device of the present invention has a reference number of 212, 312, 412, 512 etc., corresponding to the housing X12 in FIGS. 2, 3, 4, 5, etc. where X is the number of the figure in which the reference numeral appears.

One type of navigational system includes Global Positioning Systems (GPS). Such systems are known and have a variety of uses. In general, GPS is a satellite-based radio navigation system capable of determining continuous position, velocity, time, and in some embodiments, direction information for an unlimited number of users. Formally known as NAVSTAR, the GPS incorporates a plurality of satellites which orbit the earth in extremely precise orbits. Based on these precise orbits, GPS satellites can relay their location to any number of receiving units.

The GPS system is implemented when a device specially equipped to receive GPS data begins scanning radio frequencies for GPS satellite signals. Upon receiving a radio signal from a GPS satellite, the device can determine the precise location of that satellite via one of different conventional methods. The device will continue scanning for signals until it has acquired at least three different satellite signals. Implementing geometrical triangulation, the receiver utilizes the three known positions to determine its own two-dimensional position relative to the satellites. Additionally, acquiring a fourth satellite signal will allow the receiving device to calculate its three-dimensional position

by the same geometrical calculation. The positioning and velocity data can be updated in real time on a continuous basis by an unlimited number of users.

In fact, although GPS enabled devices are often used to describe navigational devices, it will be readily appreciated that satellites need not be used at all to determine a geographic position of a receiving unit, since cellular towers or any customized transmitting radio frequency towers can be deployed and combined in groups of three or more. With such a configuration, any standard geometric triangulation algorithm can be used to determine the exact location of the receiving unit. In this way, personal hand-held devices, cell phones, intelligent appliances, intelligent apparel, and others can be readily located geographically, if appropriately equipped to be a receiving unit.

FIG. 1 shows one representative view of a GPS denoted generally by reference numeral 100. A plurality of satellites 120 are in orbit about the Earth 124. The orbit of each satellite 120 is not necessarily synchronous with the orbits of other satellites 120 and, in fact, is likely asynchronous. A device that includes a GPS receiver 140 of the present invention is shown receiving spread spectrum GPS satellite signals 160 from the various satellites 120.

The spread spectrum signals 160 continuously transmitted from each satellite 120 utilize a highly accurate frequency standard accomplished with an extremely accurate atomic clock. Each satellite 120, as part of its data signal transmission 160, transmits a data stream indicative of that particular satellite 120. It will be appreciated by those skilled in the relevant art that the Device that includes a GPS receiver 140 must acquire spread spectrum GPS satellite signals 160 from at least three satellites 120 for the Device that includes a GPS receiver 140 to calculate its two-dimensional position by triangulation. Acquisition of an additional signal 160, resulting in signals 160 from a total of four satellites 120, permits Device that includes a GPS receiver 140 to calculate its three-dimensional position.

Of course as previously presented and as is readily appreciated by those skilled in the art, GPS satellites and GPS receiving devices are not required by the tenets of the present invention, since any receiving device capable or receiving the location from at least three transmitting locations can perform basic triangulation calculations to determine the relative position of the receiving device with respect to the transmitting locations.

For example, at least three cellular towers can each transmit their location information to a receiving cellular phone, or any other receiving device, and if the phones or devices are equipped to perform the triangulation algorithm, then the location of the cellular phone or device can be readily resolved. By further way of example, an amusement park or entertainment facility can deploy three or more transmitting radio frequency devices and provide users with receiving units capable of performing a triangulation algorithm to determine the receiving units location within the amusement park or entertainment facility. In this way, it is readily apparent that a receiving unit need not be exclusively GPS enabled to benefit from the teachings of the present invention.

FIG. 2A illustrates a front view of an electronic navigational device 210 according to the teachings of the present invention. FIG. 2A illustrates the top surface of the navigational device 210. In some embodiments, the navigational device 210 shown in FIG. 2A can include other functions, such as a personal digital assistant ("PDA") computing capability or cellular transceiver. The GPS navigational

device 210 operates with an operating system ("OS") such as, for example, the well-known Palm or Pocket PC operating systems, the lesser-used Linux OS or a proprietary OS. The hand-held, electronic, navigational device 210 includes a housing 212 having an opening 214 therein. Within the housing 212 is a GPS patch antenna 216 (which is shown in phantom in FIG. 2A). In the embodiment shown in FIG. 2A, the antenna includes a patch antenna located on a top portion of the display. The housing 212 is generally rectangular with a low profile and has a display 200 viewable through the opening 214. A touch panel 220 is positioned within the opening 214. The touch panel 220 is transparent, the touch panel 220 is mounted within the opening and the display 200 is viewable through the touch panel 220 and the opening 214. The touch panel 220 is touch sensitive and can be responsive to a user's digit or a stylus. It should be noted that the display 200 is not limited to any particular type of display. The housing 212 has a first end 222 and a second end 224. The navigational device 210 includes a number of control buttons, or input keys 228 positioned toward one edge or end 224. The invention, however, is not so limited by the position of the control buttons 228. It should be noted that the input keys 228 can be positioned toward another edge or at any other suitable location on the housing 212. The housing may have various slots, jack openings, and could be provided with cards for various purposes. The openings or slots provided are assembled within the housing so as to eliminate potential leakage paths. On another edge or end 225 of the housing 212 there is an infrared data port 235 ("IRDA"). In the embodiment shown in FIG. 2A, the IRDA is positioned within a molded opening in the housing 212 and covered with a data port cover 236.

Also attached to the exterior of the housing 212 is a molded plate 230. The plate 230 includes an inclined surface 232 which engages a corresponding slot of a receptacle (not shown). The receptacle may be attached to the dashboard of a vehicle. The plate 230 slips within a corresponding slot of the receptacle to temporarily mount the housing 212 to the dashboard. The circular shape of the plate 230 allows the user to turn the device 210 to any desired position so that the user can more easily view the display 200, reach the control buttons 228, or actuate the touch panel 220. The receptacle engages the plate 230 with sufficient force to retain the hand-held, electronic device 210 in position during operation of the vehicle. In other words, the receptacle will hold the hand-held, electronic device 210 as the vehicle vibrates during normal operation or encounters bumps. The user can remove the hand-held, electronic device 210 when the vehicle is not in use. This lessens the potential that thieves may break into the vehicle to steal the hand-held, electronic device 210. Furthermore, in some embodiments, the hand-held, electronic device 210 is operable when hand-held so that the user may use the hand-held, electronic device 210 in another vehicle or while outdoors in a rural or in an urban area. Some embodiments of the device 210 include batteries.

It should be understood that the structure shown is of a navigational unit having a GPS. Other physical features and functionality, such as a cellular telephone, or a PDA, could be included with the GPS navigational device and are contemplated as within the scope of this invention.

FIG. 2B illustrates an end of the embodiment of a hand-held, electronic device 210 shown in FIG. 2A. The housing 212 includes a first half 211 and a second half 213. The opening 214 for the display 200 is in the second half 213 of the housing 212. The touch panel 220 is mounted within the opening 214. The first half 211 and the second half 213 are sealed with respect to one another. Also shown in FIG.

2B is a sealed two position power switch **240** in the first half **211** of the housing **212**. The power switch **240** is sealed so that moisture on the exterior surface of the housing **212** does not leak into the interior of the housing. The opening associated with the power switch is molded within the housing **212** and specifically within the first half **211** of the housing **212** to prevent a leakage path from the exterior to the interior of the housing.

FIG. 2C illustrates a top view of an embodiment of a hand-held, electronic device **210** shown in FIG. 2A. Again, FIG. 2C illustrates that the housing **212** includes a first half **211** and a second half **213**. The openings **214** for the touch panel **220** and the display **200** are in the second half **213** of the housing **212**. The control buttons **228** are also in the second half **213** of the housing **212**. The first half **211** of the housing **212** includes a splash proof data card door **250**. The splash proof data card door **250** seals with respect to the housing **212**. The splash proof data card door **250** covers a slot for receiving a data card, such as compact flash, smart media, secure digital, or any other data source. The data card is used to store instruction sets for the electronics within the interior of the housing **212**. The data card slot (not shown) is covered by the data card door **250** to prevent a leakage path to the interior of the housing **212**. That is, the splash proof data card door **250** is sealed with respect to the first half **211** of the housing **212** to keep the hand-held, electronic device **210** waterproof.

FIG. 2D illustrates an isometric perspective view of an embodiment of a hand-held, electronic device **210** shown in FIGS. 2A–2C. The isometric view of the hand-held, electronic device **210** shows the positioning of the power switch **240**, the splash proof data card door **250**, the control buttons **228**, the touch panel **220**, the IRDA port **235** and the plate **230**. It should be noted that the position of these various components can shift and still be within the scope of this invention.

FIGS. 3–9 are provided as illustrative examples of hardware embodiments for a portable, hand-held, electronic device that includes a navigational device according to the teachings of the present invention. It should be appreciated that other suitable designs for a hardware device would also be within the scope of the present invention.

FIG. 3 illustrates a cross-sectional view along line 3–3 in FIG. 2 of the hand-held electronic device **310**. The portable hand-held electronic device **310** includes a housing **312** having an opening **314** in a second half **313** of the housing **312**. The hand-held device has a touch panel **320** which is mounted and viewable through the opening **314**. The touch panel **320** is transparent. The device **310** includes a display **300** mounted within the housing **312** and viewable through the touch panel **320**. The housing also includes a patch antenna **316** which is positioned therein. In the embodiment shown in FIG. 3, the patch antenna is positioned along a top surface of the display **300**. That is, the patch antenna **316** is positioned so that it is substantially horizontal with the plane of the earth when mounted within a vehicle using a plate **330**. Also included within the housing **312** is an internal rate gyro **390** or other suitable dead-reckoning component. The internal rate gyro **390** is used for calculating routings when a navigational signal is lost.

Along the edge of the opening **314** is a mounting apparatus **340**. The mounting apparatus **340** circumscribes the edge of the opening **314**. The mounting apparatus **340** includes a first pocket **341** and a second pocket **342**. The two pockets **341** and **342** form a first leg **344** and a second leg **345** which extend away from the front face or top of the

housing **312** and specifically made integral with the second half **313** of the housing **312**. The mounting apparatus **340** is molded with the rest of the housing **312** or made integral with the rest of the housing **312**. The mounting apparatus is used to make a watertight seal around the touch panel **320**. The mounting apparatus can also be used to provide a shock mount for the touch panel **320**. The shock mount will be further detailed in FIGS. 7 and 8. The waterproof aspects of the mounting apparatus **340** will be further detailed in FIGS. 7–9.

Also included within the housing **312** is a backing bracket or backing plate **350**. The backing bracket or backing plate **350** is mounted to the second half **313** of the housing **312** and is positioned near the edge of the touch panel **320**. The backing plate has an opening **352** therein so that the backing plate **350** essentially forms a frame around the edge of the touch panel **320** to support the edge of the touch panel **320**. The backing plate **350** is typically made of sheet metal, although it should be noted that other materials can be used in order to form the backing plate **350**. In the embodiment shown in FIG. 3, the backing bracket or backing plate **350** fastens the touch panel **320** to a second half **313** of the housing **312**.

FIG. 4 illustrates a cross-sectional view along line 4–4 in FIG. 2 of the hand-held electronic device **410**. More specifically, FIG. 4 shows a cross sectional view of a second half **413** of the housing **412**. FIG. 4 illustrates more clearly the mounting of the touch panel **420**. A complete first half **411** of the housing **412** is not shown in FIG. 4 for the sake of clarity. The hand-held electronic device **410** includes the second half **413** of the housing **412** that has an opening **414** therein. The portable electronic hand-held device **410** also includes a touch panel **420**. A mounting device or mounting apparatus **440** circumscribes the opening **414** and is used to mount the touch panel **420** within the opening **414** of the housing **412** so that it is viewable through the opening **414** while being waterproof. In some embodiments, the backing bracket or backing plate **450** fastens to the second half **413** of the housing **412**. In some embodiments, the mounting apparatus **440** can include a shock mount portion. Situated near an interior major surface of the touch panel **420** is a backing plate **450**. The backing bracket or backing plate **450** is typically made of sheet metal and includes an opening **452** therein. The backing bracket or backing plate frames the touch panel **420** on the interior side of one of the major surfaces of the touch panel **420**. The backing bracket or backing plate **450** frames the touch panel **420** along the periphery of the touch panel **420** and provides support around the edges of the touch panel. The backing bracket or backing plate **450** is mounted to the second half **413** of the housing **412** via fasteners **415**. In one embodiment, the fasteners include screws, or other suitable fasteners or the like. Also included within the housing **412** is a patch antenna. Although the patch antenna is not visible in FIG. 4, the patch antenna is operatively coupled to a printed circuit board which includes a microprocessor and a memory. Computer-executable instruction sets may be stored within the memory. The instruction set is used by the microprocessor to perform various calculations including route calculations. The patch antenna is operatively coupled to the microprocessor and the memory so that the patch antenna can acquire signals from GPS satellites or other positioning signals, such as RF signals and the like, to determine the location of the hand-held, portable electronic device **410**. The processor and antenna are further discussed in FIGS. 10 and 11.

The patch antenna can also be used to receive all or a portion of the instruction set from a remote server or other

communication device. In other words, in some embodiments the instruction set can be housed within the onboard microprocessor and onboard memory, and in other applications, some or all of the instruction set may be forwarded to the onboard microprocessor and onboard memory. Further details are discussed with respect to FIG. 12.

FIG. 5 is a front cutaway view of the hand-held, electronic device 510 as shown in FIGS. 2-4. The portable, hand-held electronic device includes a housing 512. Attached to the housing 512 is the backing bracket or backing plate 550. The backing bracket has an opening therein 552. The backing bracket 550 is attached to the housing using fasteners 515. Also located within the housing is a patch antenna 516.

FIG. 6 is a cross-sectional view of a typical touch panel 620 of the handheld, electronic device. The touch panel 620 includes a thin, flexible film 622 which is positioned near a layer of rigid material 624. The thin film 622 and the rigid material 624 each have a layer of conductive material 630, 632, respectively, such as indium, tin, oxide printed on a major surface. When thin film 622 is deflected, the conductive material 632 touches the conductive material 630 to create a closed circuit. It should be noted that the touch panel 620 is not limited to the type of conductive film placed on the thin, flexible film 622 or the rigid material 624. A touch panel with any type of conductive film is contemplated by the invention. The layer of rigid material 624 is typically more rigid than the housing 212, 312, 412, 512 of the portable electronic device 210, 310, 410, 510. The thin, flexible film 622 is attached to the rigid backing layer 624 by an adhesive gasket 626. The adhesive gasket 626 keeps the thin, flexible film 622 separated from the rigid backing 624 of the touch panel 620. The rigid backing can be made of plastic or glass. Other materials can also be used. Glass seems to be the most commonly used rigid material 624. Therefore, the rigid material 624 needs to be shock-mounted with respect to the housing 212, 312, 412, 512, so that the portable, electronic, hand-held device 210, 310, 410, 510 is more rugged. The touch panel 220, 320, 420, 520, 720, 820, 920 shown in FIGS. 2-5, as well as in FIGS. 7-9, each have a similar structure as shown in FIG. 6. However for the sake of simplicity the touch panel 220, 320, 420, 520, 720, 820, 920, is merely shown as one solid block of material in FIGS. 2, 3, 4, 5, 7, 8 and 9. It should be noted, however, that even though the touch panel is shown as a solid block of material, it is actually a rigid backing 624 with a thin, flexible film 622 held away from the rigid backing by the adhesive gasket 626. By applying pressure to the touch panel with either a fingertip or a stylus, inputs and commands can be made to the portable electronic device. As mentioned previously, a major surface of the rigid material and a major surface of the flexible material are provided with an electrically conductive film so that when the flexible material is deflected to touch the rigid material a closed circuit indicating the location of the contact is formed.

FIG. 7 is a cross-sectional view of a portion of the housing near the opening which details one embodiment for mounting the touch panel 720 with respect to the housing 712. The housing 712 includes the mounting apparatus 740. The mounting apparatus 740 includes a first pocket 741 and a second pocket 742. The mounting apparatus 740 includes a first leg 744 and a second leg 745. As shown in FIG. 7, the touch panel 720 is shock-mounted using a first viscoelastic shock mount member 760 and a second viscoelastic shock member 762. The first viscoelastic shock member 760 is sandwiched between an edge of the touch panel 720 and a portion of the first leg 744 and a portion of the second leg

745. As shown in FIG. 7, the bottom portion of the second leg 745 of the mounting apparatus is entirely covered to sandwich the first viscoelastic member 760 between the two legs 744, 745 of the mounting apparatus and the edge of the display 720. The second viscoelastic member 762 is sandwiched between the backing member 750 and the edge of the touch panel 720. The viscoelastic members 760, 762 can be made from a variety of materials, including foam tape which may have an adhesive backing. The viscoelastic elements or members 760, 762 can extend all the way around the periphery of the touch panel 720. It is not necessary, however, to have the viscoelastic members 760, 762 extend all the way around the periphery of the touch panel 720 in order to obtain an adequate shock mount to increase the drop resistance of the portable, hand-held, electronic device 210, 310, 410, 510.

Within the pocket 741 is a flexible adhesive 770. The flexible adhesive 770 fills the pocket 741 and can cover a portion of a major surface 721 of the touch panel and covers an edge 722 of the touch panel 720. The flexible adhesive 770 provides a moisture barrier which prevents moisture from passing from the exterior portion of the touch panel 720 to the interior of the housing 712. The flexible adhesive also serves as a shock mount. During a drop or other shock event, the flexible adhesive 770 flexes and cradles the edge of the touch panel 720. The flexible adhesive 770 is typically silicon and preferably is a room-temperature vulcanization ("RTV") silicon. It is important that the adhesive fill the entire pocket 741 around the whole periphery of the touch panel 720 and about the periphery of the mounting apparatus 740 near the opening 714 in the housing 712. In other words, the flexible adhesive 770 provides a moisture barrier around the entire edge of the touch panel 720 to prevent a leakage path from forming between the exterior surface of the touch panel 720 and the interior of the housing 712. Thus, the mounting apparatus 740 shown in FIG. 7 includes a flexible adhesive 770 which wraps around a portion of the major surface 721 of the display as well as the edge 722 of the touch panel 720. This flexible adhesive 770 goes around the entire periphery of the display and provides a moisture barrier to prevent leakage paths between the exterior surface of the touch panel 720 and the exterior of the housing 712 and the interior of the housing 712. The flexible adhesive 770 also acts as a shock mount, since the flexible adhesive flexes during a shock event or a drop. In addition, the mounting apparatus 740 includes a first viscoelastic pad 760 and a second viscoelastic pad 762. These can also ring the entire circumference or outer perimeter of the touch panel 720. It should be noted that the viscoelastic elements 760, 762 do not necessarily have to go all the way around the periphery of the display in order to be effective as shock mounts.

The touch panel 720 is mounted between the mounting apparatus 740 and the backing bracket 750. The touch panel 720 is transparent. Mounted within the housing 712 is display 700. The display 700 is viewable from the exterior of the housing 712 through the transparent touch panel 720.

FIG. 8 is a cross-sectional view of a portion of the housing 812 near the opening 814 in the housing, which details another embodiment for mounting the touch panel 820 with respect to the housing 812 in the hand-held, electronic device 810. Near the opening 814 is a mounting apparatus 840 which includes a first pocket 841 and a second pocket 842. The pockets 841 and 842 result in a first leg 844 and a second leg 845. The legs 844 and 845 contact a major surface 821 of the touch panel 820. The major surface 821 corresponds to the portion of the touch panel 820 which is

also exterior to the internal portion of the housing **812**. Another major surface **823** faces the interior of the housing **812**. A viscoelastic member **862** is sandwiched between a major surface **823** of the touch panel **820** and the backing bracket **850** which is mounted to the interior of the touch panel **820**. The viscoelastic member **862** serves as a shock mount since the touch panel **820** typically includes a fragile or rigid element, such as a glass layer. The pocket **841** is filled with a flexible adhesive **870**. The adhesive **870** also serves a shock absorbing function. The adhesive **870** can cover a portion of the major surface **821** of the touch panel **820** as well as the edge **822** of the touch panel **820**. The flexible adhesive **870** is a silicon adhesive and produces a water barrier or moisture barrier between the interior of the housing **812** and the exterior of the housing **812** and touch panel **820**. Therefore, the pocket **841** of the mounting apparatus **840** extends all the way around the edge of the touch panel **820** to prevent any leakage path from the exterior of the housing **812** to the interior of the housing. The viscoelastic member **862** may also extend completely around the circumference of the touch panel **820**, or it may pass around certain portions at the circumference of the touch panel **820**. The viscoelastic member **862**, as well as the flexible adhesive **870**, dampen any shock that may result from a drop or other shock event that may occur with respect to the housing **812** of the portable, hand-held, electronic device **810**. The viscoelastic layer **862** can be any sort of material including a flexible tape or a foam tape that has an adhesive backing. The flexible adhesive **870** typically is a silicone and preferably, but not limited to, a RTV silicone, which vulcanizes at room temperature.

The touch panel **820** is mounted between the mounting apparatus **840** and the backing bracket **850**. The touch panel **820** is transparent. Mounted within the housing **812** is display **800**. The display **800** is viewable from the exterior of the housing **812** through the transparent touch panel **820**.

FIG. **9** shows yet another embodiment of the mounting apparatus for mounting the touch panel **920** with respect to the housing **912** of the hand-held, electronic device **910**. In this particular hand-held, electronic device **910** there is no backing member such as that shown in FIGS. **2, 3, 4, 5, 7,** and **8**. In this particular instance, the mounting apparatus **940** includes a first pocket **941**. There is no second pocket. Rather, the volume the mounting apparatus between a first leg **944** and a second leg **945** is solid plastic. A rigid adhesive **971** is placed in the pocket **941**. The area between and including first leg **944** and the second leg **945** contact the major surface **921** of the touch panel **920** which includes an exterior portion. In this embodiment, this contact surface is maximized to evenly distribute any shock or force the touch panel **920** may experience. The rigid adhesive **971** is placed in the pocket. The rigid adhesive contacts the outside edge **922** of the touch panel **920**. The rigid adhesive is preferably UV-cured so that it can be cured during manufacture. The rigid adhesive **971** then grips or holds the touch panel **920** by the portion contacting the major surface **921** and by the outside edge **922** of the touch panel **920**. In this particular embodiment, the idea is to rigidly hold the touch panel **920** in place so that if a shock event should occur, there is relatively little if any motion between the touch panel **920** and the mounting apparatus **940** and the housing **912** of the hand-held, electronic, portable device **910**. The rigid adhesive **971** which is in the pocket **941** is continuous around the lip or outer edge of the touch panel and provides a moisture barrier to prevent leakage from the exterior to the interior of the housing **910**.

The touch panel **920** is mounted to the mounting apparatus **940**. The touch panel **920** is transparent. Mounted

within the housing **912** is display **900**. The display **900** is viewable from the exterior of the housing **912** through the transparent touch panel **920**.

It should be noted that there may be additional moisture barriers put in place in addition to any of the adhesive barriers that are shown in FIGS. **7, 8,** and **9**. For example, a gasket could be placed on either of the first legs **844, 944** so that the gasket is sandwiched between the first leg **844, 944** and the touch panel **820, 920**. Similarly, a gasket could be placed on the second leg **745, 845, 945** so that it is sandwiched between the bottom of the leg and the touch panel **720, 820, 920**.

FIG. **13** is another embodiment of the mounting apparatus **1340** for mounting the touch panel **1320** with respect to the housing **1312** of a hand-held electronic device **1310**. In this particular hand-held, electronic device **1310**, a C-shaped gasket **1390** wraps around three surfaces of the edge of the touch panel **1320**. The C-shaped gasket **1390** wraps around the edge **1322** of the touch panel **1320** and also contacts a portion of the first major surface **1321** and a portion of the second major surface **1323** of the touch panel **1320**. The mounting apparatus **1340** is essentially a solid piece of plastic having a pocket **1341** therein. A portion of the C-shaped gasket **1390** fits within the pocket **1341** in the mounting member **1340**. A backing bracket **1350** is also provided. The backing bracket **1350** compresses the gasket **1390** in a first direction. The touch panel **1320** is sized so that the gasket **1390** is also compressed in a second direction towards the housing **1312**. In operation, no glue or adhesive is required to shock mount the touch panel **1320** and form a waterproof seal. The gasket **1390**, when compressed by the outer edge **1322** of the touch panel **1320** and by the backing bracket **1350**, provides both a shock mount and a water proof seal. The touch panel **1320** is mounted between the mounting apparatus **1340** and the backing bracket **1350**. The touch panel **1320** is transparent. Mounted within the housing **1312** is a display **1300**. The display **1300** is viewable from the exterior of the housing **1312** through the transparent touch panel **1320**.

FIG. **10** is a block diagram of one embodiment for the electronic components within the hardware of FIGS. **2A-2D**, such as within housing **212** and utilized by the electronic navigational device. In the embodiment shown in FIG. **10**, the electronic components include a processor **1010** which is connected to an input **1020**, such as keypad, touch panel or infrared data acquisition port via line **1025**. It will be understood that input **1020** can alternatively be a microphone for receiving voice commands. Processor **1010** communicates with memory **1030** via line **1035**. Processor **1010** also communicates with display screen **1040** via line **1045**. An antenna/receiver **1050**, such as a GPS antenna/receiver is connected to processor **1010** via line **1055**. It will be understood that the antenna and receiver, designated by reference numeral **1050**, are combined schematically for illustration, but that the antenna and receiver may be separately located components, and that the antenna may be a GPS patch antenna or a helical antenna. The electronic components of shown in FIG. **10** include a transceiver **1060** which is coupled to the processor **1010** via line **1065**. The electronic components include I/O ports **1070** connected to processor **1010** via line **1075**. The I/O ports **1070** can include but are not limited to serial, digital, discrete, optoelectrical, or other I/O ports. The electronic components further include at least one dead reckoning component **1080** connected to the processor **1010** via line **1085**. According to the teachings of the present invention, that at least one dead reckoning component **1080** includes, by way of example and

not by way of limitation, a rate gyro as the same are known and understood by one of ordinary skill in the art. Examples of such a dead reckoning positioning functionality include, but are not limited to, the dead reckoning positioning hardware and algorithms as described in commonly assigned applications entitled; “Portable Navigation Device with Integrated GPS and Dead Reckoning Capabilities,” application Ser. No. 10/184,844, and “Systems and Methods with Integrated GPS and Dead Reckoning Capabilities,” application Ser. No. 10/184,373. The invention, however, is not so limited. One of ordinary skill in the art will appreciate, upon reading this disclosure, that other dead reckoning components suited to provide the advantages of the present invention are considered equally within the scope of the present invention.

FIG. 11 is a block diagram of another embodiment for the electronic components within the hardware of FIGS. 2A–2D according to the teachings of the present invention. In this particular embodiment, the electronics can include more than one function. One example of such a multifunctional device includes a device capable of a first function with global positioning and routing, and a second function, such as keeping addresses, calendars and files used for linking with another computer. The second function or set of functions are commonly associated with a personal data assistant (“PDA”). It should be noted that the second function could be a multitude of other functions and is not limited to the functions commonly associated with a PDA. For example, the other function could be a cellular phone, or any other portable electronic computing device. It should be noted that the electronic device could also include more than two different functions. The electronic components shown in FIG. 11 include a processor 1136 which is connected to the GPS antenna 1114 through GPS receiver 1138 via line 1141. The processor 1136 interacts with an operating system (such as PalmOS; Pocket PC) that runs selected software depending on the intended use of the electronics, such as software for driving a PDA, cellular phone, or other hand held device. Processor 1136 is coupled with memory 1142 such as RAM via line 1144, and power source 1146 for powering the electronic components. The processor 1136 communicates with a display, 1126 via data line 1148.

The electronic components further include two other input sources that are connected to the processor 1136. Control buttons and the touch panel 1128 are connected to processor 1136 via line 1151 and a map data cartridge 1133 inserted into cartridge bay 1132 is connected via line 1152. An I/O port 1154 is connected to the processor 1136 via line 1156. Cellular antenna 1116 is connected to cellular transceiver 1158, which is connected to the processor 1136 via line 1166. Processor 1136 is connected to the speaker/headphone jack 1134 via line 1162. The multifunction electronic device may also include an infrared port (not shown) coupled to the processor 1136 that may be used to beam information from one electronic device to another electronic device. The same will be explained in more detail below.

According to the teachings of the present invention, and as shown in the embodiments of FIGS. 10 and 11, the electronic components of the present invention include a memory, shown as 1142 in FIG. 11, which is adapted to store and/or house a set of executable instructions, programs, and/or program modules. For ease of illustration, the memory will be discussed in reference to FIG. 11 where the memory 1142 is coupled to the processor 1136 via line 1144. The description, however, applies analogously to the memory 1030 in FIG. 10. As one of ordinary skill in the art will appreciate, the memory 1142 is adapted to communicate

with the processor 1136. In the invention, the memory 1142 is further adapted to store or house navigation related data and is adapted to house or store software operable to perform routing algorithms. Examples of such routing algorithms include, but are not limited to, routing algorithms as described in commonly assigned applications entitled; “Systems and Methods for a Navigational Device with Improved Route Calculation Capabilities,” application Ser. No. 10/028,057, now U.S. Pat. No. 6,545,637, “Systems and Methods for a Navigational Device with Forced Layer Switching Based on Memory Constraints,” application Ser. No. 10/027,159, now U.S. Pat. No. 6,581,003, “Systems and Methods for a Navigational Device with Automated Next Turn Page,” application Ser. No. 10/029,917, “Navigation System, Method and Device with Voice Guidance”, application Ser. No. 10/029,732, and “Navigation System, Method and Device with Detour Algorithm”, application Ser. No. 10/028,343, now U.S. Pat. No. 6,687,615, each of which is incorporated herein in full by reference.

According to the teachings of the present invention, the navigation related data includes cartographic data. The cartographic data includes a number of locations and data indicative of thoroughfares of a plurality of types connecting certain ones of the locations. In one embodiment, the navigation related data includes a calculated route between at least two of the number of locations. Further, according to the teachings of the present invention, the software stored or housed within memory 1142 includes software operable to perform one or more applications for navigation. As used herein, software operable to perform one or more applications for navigation includes, but is not limited to, software operable to find points of interest. In one embodiment, the navigation related data includes navigation data selected from the group of a number of waypoints, a planned route, and points of interest. In one embodiment, the points of interest include points of interest selected from the group of geographical points of interest, entertainment venues, dining venues, historical points of interest, and lodging venues. In one embodiment, the navigation related data includes navigation data selected from the group of automobile navigation data, marine craft navigation data, pedestrian navigation data, and hiking navigation data.

In one embodiment, the device is GPS enabled. In this embodiment, the software is operable to calculate an estimated time of arrival of the device to the a desired destination using an integrated GPS capability of the device.

According to the teachings of the present invention, and as shown in the embodiments of FIGS. 10 and 11, the electronic components of the present invention include a transceiver shown as 11160, which is coupled to the processor. For ease of illustration, the transceiver 1160 will be discussed in reference to FIG. 11 where the transceiver 1160 is coupled to the processor 1136 via line 1161. The description, however, applies analogously to the electronic components shown in FIG. 10. As stated above, the memory is adapted to store or house software. According to the teachings of the present invention, software is provided which includes a set of executable instructions, programs, and or program modules adapted to control transceiver 1160 such that the transceiver 1160 can transmit and receive navigation data between a handheld electronic device and an other portable and/or handheld device. For example, in one embodiment, the software includes a set of executable instructions adapted to transmit and receive the navigation related data via a commercial communications network.

One example of a commercial communications network includes an analog cellular network using plain old tele-

15

phone service (POTS). Another example of a commercial communications network to which the present invention is adapted includes a digital packet switched cellular network such as a personal communications service (PCS) network. As one of ordinary skill in the art will understand upon reading this disclosure, the transceiver **1060**, **1160** of the present invention is adapted to transmit and receive navigation related data via the Internet using Internet Protocol (IP). Thus, the present invention includes a handheld electronic device which is adapted to transmit and receive navigation related data over a wide area network (WAN) using any number or combination of hardwired and/or wireless communication channels. For instance, the transceiver of the present invention is adapted to transmit and receive navigation related data using a wireless application protocol (WAP). However, as one of ordinary skill in the art will understand upon reading and comprehending this disclosure, the invention is not limited to single one or particular combination of WAN communication channels or protocols. That is the transceiver can be instructed to transmit and receive navigation related data in a 3G GSM/CDMA network, and other networks of the like.

Similarly, according to the teachings of the present invention, the transceiver **1060**, **1160** is adapted to transmit and receive navigation related data over a local area network (LAN). In this embodiment, the transceiver **1060**, **1160** is adapted to operate in a short range network and wirelessly transmit and receive the navigation related data between a handheld electronic device and an other portable and/or handheld electronic device using either infra-red signaling and/or a Bluetooth signaling technology as the same are known and understood by one of ordinary skill in the art. The invention is not so limited. As one of ordinary skill in the art will understand upon reading this disclosure, the electronic devices described herein include multipurpose devices, such as PDAs, cell phones and other intelligent appliances/apparel of the like, which can wirelessly transmit navigation related data from one such device to another. That is, in one embodiment, according to the teachings of the present invention, the handheld electronic device includes devices selected from the group of cell phones, intelligent apparel, and PDAs. In one embodiment, the other portable and/or handheld electronic device similarly includes devices selected from the group of cell phones, intelligent apparel, and PDAs.

According to the teachings of the present invention, and as shown in the embodiments of FIGS. **10** and **11**, the electronic components of the present invention include a dead reckoning component shown as **1180** which is coupled to the processor **1010**, **1130**. For ease of illustration, the dead reckoning component **1080**, **1180** will be discussed in reference to FIG. **11** where the dead reckoning component **1180** is coupled to the processor **1136** via line **1181**. The description, however, applies analogously to the electronic components shown in FIG. **10**. As stated above, the memory is adapted to store or house software. According to the teachings of the present invention, software is provided which includes a set of executable instructions, programs, and or program modules adapted to control the dead reckoning component **1180** such that the dead reckoning component **1180** can be activated and provide navigation services to the device.

As identified herein, the present invention provides a portable electronic device which includes both a triangulation positioning and a dead reckoning positioning functionality. In one embodiment, the triangulation positioning functionality includes a GPS functionality and the dead

16

reckoning functionality includes a rate gyro. Examples of such a triangulation positioning and a dead reckoning positioning functionality include, but are not limited to, the triangulation positioning and a dead reckoning positioning hardware and algorithms as described in commonly assigned applications entitled; "Portable Navigation Device with Integrated GPS and Dead Reckoning Capabilities," application Ser. No. 10/184,844, and "Systems and Methods with Integrated GPS and Dead Reckoning Capabilities," application Ser. No. 10/184,373. The invention, however, is not so limited. In the invention, the processor of the device is adapted to operate on a set of computer executable instructions to determine, or resolve, a position of the device when the triangulation positioning service and/or signals are available. The processor of the device further adapted to operate on the set of computer executable instructions to determine, or resolve, a position of the device using the dead reckoning functionality to supplement the triangulation positioning functionality when the triangulation positioning functionality is interrupted, degraded, or otherwise unavailable. In this manner the present invention allows for the device to continue processing and/or tracking a location or position of the device when such triangulation positioning services are interfered with such as in "urban canyons" or when the device is indoors. Similarly, device can thus continue navigating a route for the device as the same is described herein.

As shown in FIGS. **10** and **11**, the device further includes a touch panel in communication with the processor and the memory, e.g. touch panel portion of **1128** in FIG. **11**. The display is adapted to display all or part of a "convergence" and/or a "solution." As used herein, the terms convergence and/or solution are intended to mean a complete path provided by the thoroughfares of a plurality of types connecting certain ones of the number of locations in the cartographic data.

FIG. **12** is a block diagram of an embodiment of a navigation system according to the teachings of the present invention. The navigation system includes a server **1202**. According to one embodiment, the server **1202** includes a processor **1204** operably coupled to memory **1206**, and further includes a transmitter **1208** and a receiver **1210** to send and receive communication signals. The transmitter **1208** and receiver **1210** are selected or designed according to the communication requirements and the communication technology used in the communication design for the navigation system. The functions of the transmitter **1208** and the receiver **1210** can be combined into a single transceiver.

The navigation system further includes a mass data storage **1212** coupled to the server **1202** via communication link **1214**. The mass data storage **1212** contains a store of navigation data. One of ordinary skill in the art will understand, upon reading and comprehending this disclosure, that the mass data storage **1212** can be separate device from the server **1202** or can be incorporated into the server **1202**.

The navigation system further includes a navigation device **1216** adapted to communicate with the server **1202** through the communication channel **1218**. According to one embodiment, the navigation device **1216** includes a processor and memory, as previously shown and described with respect to the block diagrams of FIGS. **10** and **11**. Furthermore, the navigation device **1216** includes a transmitter **1220** and receiver **1222** to send and receive communication signals through the communication channel **1218**. The transmitter **1220** and receiver **1222** are selected or designed according to the communication requirements and the communication technology used in the communication

design for the navigation system. The functions of the transmitter **1220** and receiver **1222** can be combined into a single transceiver.

Software stored in the server memory **1206** provides instructions for the processor **1204** and allows the server **1202** to provide services to the navigation device **1216**. One service provided by the server **1202** involves processing requests from the navigation device **1216** and transmitting navigation data from the mass data storage **1212** to the navigation device **1216**. According to one embodiment, another service provided by the server **1202** includes processing the navigation data using various algorithms for a desired application, and sending the results of these calculations to the navigation device **1216**.

The communication channel **1218** is the propagating medium or path that connects the navigation device **1216** and the server **1202**. According to one embodiment, both the server **1202** and the navigation device **1216** include a transmitter for transmitting data through the communication channel and a receiver for receiving data that has been transmitted through the communication channel.

The communication channel **1218** is not limited to a particular communication technology. Additionally, the communication channel **1218** is not limited to a single communication technology; that is, the channel **1218** can include several communication links that use a variety of technology. For example, according to various embodiments, the communication channel is adapted to provide a path for electrical, optical, and/or electromagnetic communications. As such, the communication channel includes, but is not limited to, one or a combination of the following: electrical circuits, electrical conductors such as wires and coaxial cables, fiber optic cables, converters, radio-frequency (RF) waveguides, the atmosphere, and empty space. Furthermore, according to various embodiments, the communication channel includes intermediate devices such as routers, repeaters, buffers, transmitters, and receivers, for example.

In one embodiment, for example, the communication channel **1218** includes telephone and computer networks. Furthermore, in various embodiments, the communication channel **1216** is capable of accommodating wireless communication such as radio frequency, microwave frequency and infrared communication, and the like. Additionally, according to various embodiments, the communication channel **1216** accommodates satellite communication.

The communication signals transmitted through the communication channel **1218** include such signals as may be required or desired for a given communication technology. For example, the signals can be adapted to be used in cellular communication technology, such as time division multiple access (TDMA), frequency division multiple access (FDMA), code division multiple access (CDMA), global system for mobile communications (GSM), and the like. Both digital and analog signals can be transmitted through the communication channel **1218**. According to various embodiments, these signals are modulated, encrypted and/or compressed signals as can be desirable for the communication technology.

The mass data storage includes sufficient memory for the desired navigation application. Examples of mass data storage include magnetic data storage media such as hard drives, optical data storage media such as CD ROMs, charge storing data storage media such as Flash memory, and molecular memory. Moreover, as one skilled in the art will readily appreciate the mass storage need not be a single device as a

plurality of storage devices can be logically associated to form a distributed mass storage device of the present invention.

According to one embodiment of the navigation system, the **1202** server includes a remote server accessed by the navigation device **1216** through a wireless channel. According to other embodiments of the navigation system, the server **1202** includes a network server located on a local area network (LAN), wide area network (WAN), a virtual private network (VPN) and server farms.

According to another embodiment of the navigation system, the server **1202** includes a personal computer such as a desktop or laptop computer. In one embodiment, the communication channel **1218** is a cable connected between the personal computer and the navigation device. According to one embodiment, the communication channel **1218** is a wireless connection between the personal computer and the navigation device **1216**.

FIG. **12** presents yet another embodiment for a collective set of electronic components adapted to the present invention. As one of ordinary skill in the art will understand upon reading this disclosure, the navigation system of FIG. **12** is adapted to the present invention in a manner distinguishable from that described and explained in detail in connection with FIGS. **10** and **11**.

The mass storage device **1212** connected to the server can include volumes more cartographic and route data than that which is able to be maintained on the navigational device **1216** itself. In this embodiment, the server **1202** processes the majority of a user's travel along the route using a set of processing algorithms and the cartographic and route data stored in memory **1212** and can operate on signals, e.g. GPS signals, originally received by the navigational device **1216**. Similar to the navigational device of FIGS. **2-11**, the navigation device **1216** in system **1200** is outfitted with a display **1224** and GPS capabilities **1226**.

It should be noted that the electronic components of device shown in FIGS. **2-11** and components of the system **1200** shown in FIG. **12** can be embodied as computer hardware circuitry or as a computer-readable program, or a combination of both. In another embodiment, system **1200** is implemented in an application service provider (ASP) system.

More specifically, in the computer-readable program embodiment, the programs can be structured in an object-orientation using an object-oriented language such as Java, Smalltalk, C++, and others, and the programs can be structured in a procedural-orientation using a procedural language such as C, PASCAL, and others. The software components communicate in any of a number of means that are well-known to those skilled in the art, such as application program interfaces (A.P.I.) or interprocess communication techniques such as remote procedure call (R.P.C.), common object request broker architecture (CORBA), Component Object Model (COM), Distributed Component Object Model (DCOM), Distributed System Object Model (DSOM) and Remote Method Invocation (RMI).

Of course it is readily appreciated by those skilled in the art that any programming methodology, programming language, programming interface, operating system, or computing environment, now known or hereafter developed can be readily deployed, without departing from the tenets of the present invention and all such implementation specific embodiments are intended to fall within the broad scope of the present invention.

CONCLUSION

In summary, disclosed is a hand-held portable electronic device including a housing, a processor located within the

housing, a memory in communication with the processor, and a display in communication with the processor. The display is positioned near the surface of the housing. A touch panel is placed over the display and is mounted to an opening within the housing. The touch panel is in communication with the processor and positioned on a surface of the housing. The electronic device can include an apparatus for performing a first function, and an apparatus for performing a second function. One of the functions includes a navigational component. The housing includes a flange around the opening which has a fluid seal to prevent fluid flow past the touch panel and into the housing. A shock mount may also be included within the housing to make the touch panel drop-resistant. The electronic device includes a navigational component having an instruction set for controlling the processor and memory to perform a route calculation. The electronic device may also communicate with a mass storage device adapted to store navigation data and a server adapted to communicate with the mass storage. The electronic device may also be multi-functional. The handheld device is ruggedized and waterproofed and can be used in many environments.

The hand-held, portable, electronic device is also provided with hardware and software for performing dead reckoning in the event one or more signals necessary to determine a position is lost. The portable, hand-held, electronic device is also capable of auto-routing and performing other navigational functions.

The above systems, devices and methods have been described, by way of example and not by way of limitation, with respect to reducing memory capacity requirements, increasing processor throughput, and improving overall ease of user interaction with a navigation device. That is, the systems, devices, functional data, and methods provide for generating a projected route in connection with a navigational device which is more efficient and accurate than current systems, devices, and methods, without requiring more expensive system resources. The systems, devices, functional data, and methods of the present invention offer an improved generated projected route which provide more understandable, accurate and timely capabilities in a navigation device while utilizing less resources.

Although specific embodiments have been illustrated and described herein, it will be appreciated by those of ordinary skill in the art that any arrangement which is calculated to achieve the same purpose may be substituted for the specific embodiment shown. This application is intended to cover any adaptations or variations of the present invention. It is to be understood that the above description is intended to be illustrative, and not restrictive. Combinations of the above embodiments, and other embodiments will be apparent to those of skill in the art upon reviewing the above description. The scope of the invention includes any other applications in which the above systems, devices, functional data, and methods are used. The scope of the invention should be determined with reference to the appended claims, along with the full scope of equivalents to which such claims are entitled.

What is claims is:

1. A hand-held electronic device including a navigational component, comprising:

- a housing, the housing having an opening therein;
- a display viewable through a touch panel mounted in the opening of the housing, the touch panel including:
 - a layer of rigid material; and
 - a flexible substrate layer positioned near the layer of rigid material;
- a mounting member circumscribing the opening for use in providing a watertight seal, the mounting member including:

a first leg positioned away from a top of the housing and attached to a first shock absorbing member; and a second leg positioned away from the top of the housing and attached to the first shock absorbing member and an adhesive.

2. The hand-held electronic device including a navigational component of claim 1 wherein the adhesive is a flexible adhesive.

3. The hand-held electronic device including a navigational component of claim 1 wherein the adhesive is a flexible, waterproof adhesive.

4. The hand-held electronic device including a navigational component of claim 1, wherein the adhesive is curable using an ultraviolet light.

5. The hand-held electronic device including a navigational component of claim 1, wherein the adhesive is rigid.

6. The hand-held electronic device including a navigational component of claim 1, wherein the first shock absorbing member includes a viscoelastic material.

7. The hand-held electronic device including a navigational component of claim 6, wherein the first shock absorbing member includes a layer of foam material.

8. The hand-held electronic device including a navigational component of claim 1, further comprising:

- a backing member that fits within the housing, the backing member having a portion positioned near the touch panel; and

- a second shock absorbing member opposite the first shock absorbing member and including a portion which is sandwiched between the backing member and the layer of rigid material of the touch panel.

9. The hand-held electronic device including a navigational component of claim 1, wherein the mounting member is molded with the housing.

10. The hand-held electronic device including a navigational component of claim 1, wherein the mounting member is integral with the housing.

11. A hand-held electronic device including a navigational component comprising:

- a housing, the housing having an opening therein;
- a display viewable through a touch panel positioned in the opening of the housing, the touch panel including:

- a layer of rigid material; and

- a flexible substrata layer positioned near the layer of rigid material;

- a mounting member circumscribing the opening, the mounting member including a pocket for holding an adhesive and applying the adhesive about the periphery of the touch panel;

- a processor located within the housing;

- a memory in communication with the processor, the touch panel in communication with the processor and the memory, the processor and memory capable of performing a route calculation viewable on the display; and

- a fluid seal securing the touch panel to the housing, the fluid seal being disposed in front of the periphery of and around an outer edge of the touch panel and compressed toward the mounting member by a backing bracket to provide a water proof seal and a shock mount.

12. The hand-held electronic device including a navigational component of claim 11, further comprising a device capable of performing a dead reckoning calculation.

13. The hand-held electronic device including a navigational component of claim 12, wherein the device capable of performing a dead reckoning calculation includes a rate gyro.

21

14. A hand-held electronic device comprising:
 a housing, the housing having an opening therein;
 a processor located within the housing;
 a memory located within the housing, the memory in communication with the processor;
 a display in communication with the processor and the memory, the display viewable through a touch panel mounted in the opening in the housing;
 a first component adapted to perform a first function; and
 a second component adapted to perform a second function, one of the first component and the second component including a navigational component, the navigational component including a dead reckoning component located within the housing, the dead reckoning component in communication with the processor and operable to detect a position of the hand-held electronic device when GPS signals are unavailable and an internal patch antenna adapted to acquire position signals, the housing including a flange around the opening in the housing, the flange further comprising: a fluid seal to prevent fluid flow past the touch panel and into the housing; and
 a shock mount.

15. The hand-held electronic device of claim 14, wherein the touch panel further comprises:
 a layer of rigid material; and
 a flexible substrate layer positioned near the layer of rigid material.

16. The hand-held electronic device of claim 14, further comprising an instruction set for controlling the processor and memory to perform a route calculation.

17. The hand-held electronic device of claim 14, further comprising an instruction set for controlling the processor and memory to perform a route calculation, the instruction set including user interface instructions to display the results of the route calculation on the display.

18. The hand-held electronic device of claim 14, wherein the mounting member includes a flexible adhesive.

19. The hand-held electronic device of claim 18, wherein the mounting member includes a groove for holding the flexible adhesive.

20. The hand-held electronic device of claim 14, wherein the fluid seal includes a gasket.

21. The hand-held device of claim 14, wherein the shock mount includes a viscoelastic material.

22. A navigation system comprising:
 a mass storage device adapted to store navigation data;
 a server adapted to communicate with the mass storage device; and
 a portable, multi-function electronic device further comprising:
 a housing having an opening therein;
 a processor located within the housing;
 a memory located within the housing, the memory in communication with the processor;
 a display in communication with the processor and the memory, the display viewable through a touch panel mounted to the opening in the housing, the housing including a flange around the opening in the housing, the flange further comprising:
 a fluid seal securing the touch panel to the housing, the fluid seal being compressed in a first direction by the touch panel and in a second direction by a backing bracket such that fluid flow past the touch panel and into the housing is prevented; and
 a shock mount; and
 an antenna within the housing for communicating with the server, the multi-function electronic device

22

including a navigation device adapted to perform a route calculation.

23. The navigation system of claim 22, wherein the navigation device further comprises an instruction set for controlling the processor and memory to perform a route calculation.

24. The navigation system of claim 23, wherein the instruction set includes user interface instructions for displaying the results of the route calculation on the display.

25. The navigation system of claim 23, wherein at least a portion of the instruction set resides within the processor and memory.

26. The navigation system of claim 23, wherein at least a portion of the instruction set is transmitted to the portable, multi-function electronic device from the server.

27. A hand-held electronic device including a navigational component, comprising:
 a housing, the housing having an opening therein;
 a display viewable through a touch panel mounted in the opening of the housing, the touch panel including:
 a layer of rigid material, and
 a flexible substrate layer positioned near the layer of rigid material;
 a mounting member circumscribing the opening for use in providing a watertight seal, the mounting member including:
 a first leg positioned away from a top of the housing and attached to a first shock absorbing member, and
 a second leg positioned away from the top of the housing and attached to the first shock absorbing member and an adhesive;
 a backing member that fits within the housing, the backing member having a portion positioned near the layer of rigid material of the touch panel;
 the first shock absorbing member including a portion which is sandwiched between the flexible member of the touch panel and the mounting member; and
 a second shock absorbing member including a portion which is sandwiched between the backing member and the layer of rigid material of the touch panel.

28. A hand-held electronic device including a navigational component, comprising:
 a housing, the housing having an opening therein;
 a display viewable through a touch panel mounted in the opening of the housing, the touch panel including:
 a layer of rigid material, and
 a flexible substrate layer positioned near the layer of rigid material;
 a mounting member circumscribing the opening for use in providing a watertight seal, the mounting member including:
 a leg positioned away from the top of the housing and attached to a first shock absorbing member and an adhesive, and
 wherein the first shock absorbing member is pressed against the flexible layer of the touch panel;
 a backing member that fits within the housing, the backing member having a portion positioned near the layer of rigid material of the touch panel;
 a second shock absorbing member including a portion which is sandwiched between the backing member and the layer of rigid material of the touch panel; and
 wherein the adhesive is disposed along a periphery of the flexible layer and around an outer edge of the layer of rigid material the touch panel to provide a water proof seal and a shock mount.