

(No Model.)

G. RUSSELL.
APPARATUS FOR COATING METAL SHEETS.

No. 524,736.

Patented Aug. 21, 1894.

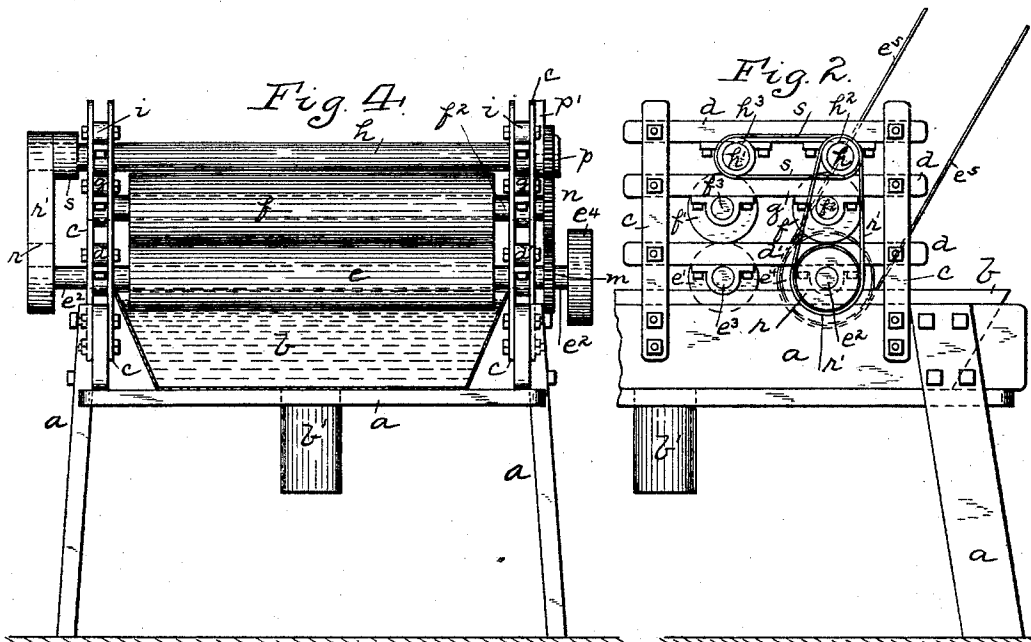
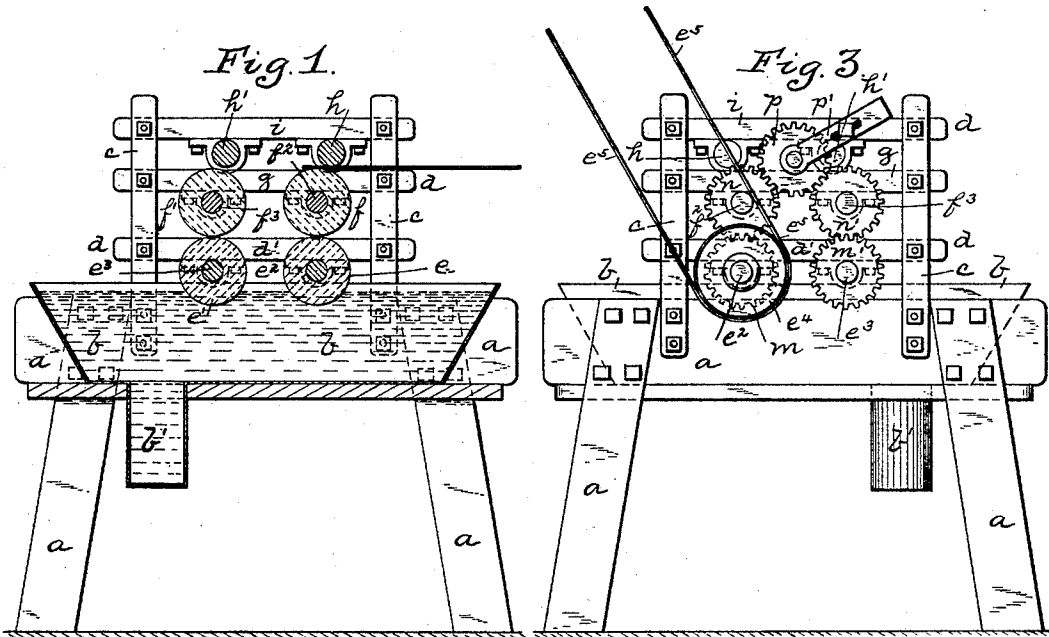

Witnesses:
Joseph Barrett,
Edw. J. Hartman.

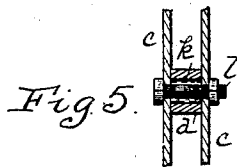

Inventor
George Russell.
By Kay, Tatten & Cook,
Attorneys.

UNITED STATES PATENT OFFICE.

GEORGE RUSSELL, OF MCKEESPORT, PENNSYLVANIA.

APPARATUS FOR COATING METAL SHEETS.

SPECIFICATION forming part of Letters Patent No. 524,736, dated August 21, 1894.

Application filed March 6, 1893. Serial No. 464,837. (No model.)

To all whom it may concern:

Be it known that I, GEORGE RUSSELL, a resident of McKeesport, in the county of Allegheny and State of Pennsylvania, have invented a new and useful Improvement in Apparatus for Coating or Enameling Metal Sheets; and I do hereby declare the following to be a full, clear, and exact description thereof.

My invention relates to the coating of sheet metal with enamel, such, for example, as the coating of what are known as ferrotype plates, the plates on which ferrotypes, or, as they are sometimes termed, tin types, are made, enameled signs and enameled sheet iron generally, such as for panel and other work. The usual process of preparing such enamel has been to dip the entire sheet into the enamel, the result of which was the coating of the sheets on both sides, and the consequent large waste of enamel, while an even distribution of the same over the sheet was exceedingly hard to obtain, or the application of the enamel to the sheet by means of a brush, which again left the sheet streaky, because an even distribution in that way was also exceedingly difficult to obtain, and had the further disadvantage of requiring the sheet to be kept with its face upward, in which position dust or dirt was more liable to adhere to the sticky surface after the enameling operation and mar the same. The object of the present invention is to improve the apparatus for coating these sheets in such way as to obtain an even distribution of the coating material, the economic use of the same, and the coating of the sheets in such way that they are not so liable to receive dust or dirt, while the coating operation can be performed much more rapidly.

To these ends my invention consists, generally stated, in a machine for practicing the invention having, generally stated, a pan containing the enamel, rolls therein to receive the enamel and carry it up into the course of the sheet, distributing rolls and metallic supporting rolls to hold the sheets in contact with the distributing rolls as will be hereinafter more fully set forth and claimed.

To enable others skilled in the art to practice my invention, I will describe the same more fully, referring to the accompanying drawings, in which—

Figure 1 is a sectional view of the machine embodying my invention. Fig. 2 is a side view on one side of the machine. Fig. 3 is a like view on the other side thereof. Fig. 4 is an end view. Fig. 5 is a detail view showing the means for regulating the positions of the housings of the rolls.

Like letters of reference indicate like parts in each.

In practicing my invention I employ apparatus which is preferably constructed as follows:—Supported in a suitable frame *a* is the pan *b* which is preferably made shallow, and in such case has at one end thereof the well *b'* to receive the gravimeter in testing the specific gravity of the enameling compound contained within the pan. The rolls employed are supported in the housings or horizontal bars *d* extending between the standards *c* which are connected to the machine frame *a* and extend up a suitable height above the same for the support of all the housings required in the machine. The housings *d'* support the rolls *e e'*, the bearings of the rolls being secured to and depending from housings, and supporting the rolls in such position that they will enter within the pan *b* so as to receive and carry up the enamel therefrom. Above these rolls are the distributing rolls *f f'* supported in the housings *g* by like bearings, and above the distributing rolls *f f'* are the metallic rolls *h h'* supported in the housings *i* by suitable bearings.

The rolls *e e' f f'* are formed of a composition of glue and other materials, the same as employed for printing rolls, the result being that the rolls themselves are soft and yielding and that by adjusting the contact between the rolls *e* and *f* or *e'* and *f'*, the amount of enamel to be carried up by the distributing rolls and delivered to the sheets may be regulated according to the pressure of the rolls upon each other. For this purpose any suitable regulating means may be employed, a simple means being illustrated, the holes in the housings through which the bolts connecting them to the standards *c* extend being made of sufficient size to permit any desired adjustment within a limited space so as to bring the rolls into contact or cause them to press against each other, or relieve them from

contact when not in use, as may be desired. Fig. 5 of the drawings illustrates this means of regulating the pressure of the rolls, the housing having the hole k therein of greater size than the bolt l , and the standards c being made of two metallic bars or strips, one extending on each side of the housing, so that the bolt passes through the enlarged hole k and by the loosening of the bolt the operator may by hand raise or lower the housing or adjust it longitudinally, as may be found desirable. Any other suitable means for regulating the pressure of the rolls, may, of course, be employed.

It will be noticed in Fig. 1 that the metallic rolls $h h'$ do not contact with the rolls $f f'$. This is considered desirable, as it is only required that the sheet shall be enameled upon one side, and the function of these rolls is to hold the sheet in contact with the enameling or distributing rolls $f f'$. For this purpose, the rolls $h h'$ are placed slightly in advance of the rolls $f f'$ and with their lower faces about on a line, or almost on a line with the top faces of the rolls $f f'$, the rolls thus serving to hold the sheet in contact without receiving any of the enamel upon the surfaces of the metallic or hard rolls. Other functions are performed by these rolls as will be hereinafter more fully described.

For the purpose of driving the rolls at the proper speed, any suitable gearing may, of course, be employed, the gearing devices shown in the drawings being arranged as follows: The shaft e^2 of the roll e extends out at one side so as to receive the pulley e^4 which is driven by a suitable belt e^5 , and upon the said shaft outside of the housing is the pinion or gear wheel m which meshes with the gear wheel n on the shaft f^2 of the roll f , power being thus transmitted through the pinions $m n$ to the upper roll f . On the shaft e^3 of the roll e' is the pinion m' which meshes with the pinion n' on the shaft f^3 carrying the roll f' . To transmit the power to the pinions $m' n'$, I employ the loose running pinion p which is carried by the yoke p' , the yoke p' being made adjustable upon one of the upper housings i , the yoke p' having a slot therein so that the pinion p may be adjusted upon the housings to gear properly both with the pinion n and the pinion n' . As the machine is in operation, the power transmitted to the shaft e^2 is thus transmitted by the pinion n to the roll f and from the pinion n through the loose pinion p and pinions $n' m'$ to the rolls $f' e'$ respectively, all these rolls being driven practically at the same speed. In order to drive the upper rolls $h h'$, I provide pulleys or collars on the shafts, the shaft e^2 having at the end opposite to that carrying the pinion m the collar r and a belt r' extending from said collar to the collar or pulley h^2 in the roll h . This pulley or collar is made of sufficient width to receive another belt s which extends over a like collar h^3 on

the roll h' , so transmitting the power to that roll.

As so constructed, when the enamel, which is a suitable surfacing for metallic surfaces, is taken up by the two lower rolls $e e'$ and carried to the upper rolls $f f'$, and the contact between these rolls is carefully adjusted so that the amount of enamel distributed over the surfaces of the upper or enameling rolls $f f'$ shall be even and regular and of a suitable thickness or quantity, according to the amount transmitted to the metallic sheet, the operator then takes the sheet, which is usually a thin sheet of iron, steel, or other metal, and passes it forward and causes it to strike against the metallic roll h . This roll forces the sheet downwardly and carries it against the roll f , so insuring the enameling or coating of the sheet at the extreme forward end thereof, so that no part of the surface of the sheet is left uncoated. The rolls draw the sheet in and the enamel upon the roll f is transmitted to the lower surface of the sheet, and as the sheet passes forward it comes in contact with the enamel roll h' which again forces it downwardly against the roll f' , and a second coating of the enamel is thus transmitted to the sheet, the double coating of the sheet insuring the covering of the entire surface thereof with the enameling compound in one pass through the machine, and soft or yielding composition rolls act to cause a very even distribution of the coating material over the sheets. The second roll f' acts both to spread the enamel fed to the sheet by the roll f and to further coat the sheet, it being preferred that the amount of enamel carried by the second roll shall be less than that carried by the first roll, this being regulated by the pressure of the rolls $e' f'$. After the sheet leaves the first set of rolls $f h$, the weight of the part which has passed beyond the second set of rolls holds it in proper contact with the coating roll f' , so that it is coated out to the extreme edge thereof and the sheet is then received by the operator who holds it by pressure upon the edge, the sheet having been coated on the lower surface so that the liability of dust or dirt adhering to the sheet during the coating operation is avoided, and being received by the operator with its coated surface down, in which position he can carry the sheet until he reaches the rack on which it is to be placed for drying or baking, when he will invert it and slip it upon the rack. The metallic rolls employed in conjunction with the yielding composition rolls thus act to hold the sheet in contact with the enameling rolls without themselves receiving any enamel, so that one surface of the sheet is coated while the other remains clean and free from enamel. At the same time, by placing these rolls slightly in advance of the enameling rolls, the metallic rolls not only hold the sheet in contact but regulate the pressure of the sheet upon the coating rolls, and while forcing the sheet

through insuring the coating of the entering edge of the sheet and the coating of the opposite end of the sheet as it leaves the machine, without the formation of any film or thickened body of enamel along the edge of the sheet. The sheets can thus be rapidly coated, as rapidly as they can be fed through the machine, while at the same time the amount of enamel transmitted to the sheets can be accurately regulated by the pressure of the composition rolls upon each other and by the passage of the sheet first between the rolls *f h* and then between the rolls *f' h'*, the double enameling of the sheet insuring the formation of a perfect enameled surface thereon. The sheets can therefore be produced much more rapidly, more perfect enameling surfaces formed, the liability of the thickened edges from the gathering of the enamel at the edges prevented, and the amount of enamel necessary for coating materially reduced.

What I claim as my invention, and desire to secure by Letters Patent, is—

1. In apparatus for coating sheet metal the combination of a soft or composition roll rotating in the direction the sheet is to be fed, and means for coating the same with enamel, and a metallic roll above the same, rotating in the direction the sheet is to be fed, the

metallic roll being set in front of, and out of contact with the soft roll, substantially as and for the purposes set forth.

2. In apparatus for coating sheet metal, the combination of a pan for holding enamel, two sets of soft or composition rolls, each having one roll within the pan and the other roll above and in contact therewith, and metallic rolls above the upper rolls of the sets, the metallic rolls being set in front of but out of contact with the upper rolls, and devices for driving said rolls, substantially as and for the purposes set forth.

3. In apparatus for coating sheet metal, the combination of a pan for holding enamel, two sets of soft or composition rolls, each having one roll within the pan and the other roll above and in contact therewith, and metallic rolls above the upper rolls of the sets, said rolls being mounted in suitable housings, said housings being adjustable within the supporting standards, substantially as and for the purposes set forth.

In testimony whereof I, the said GEORGE RUSSELL, have hereunto set my hand.

GEORGE RUSSELL.

Witnesses:

JAMES I. KAY,
J. N. COOKE.