

EUROPEAN PATENT SPECIFICATION

- ④ Date of publication of patent specification: **07.03.90** ⑤ Int. Cl.⁵: **H 01 J 61/10, H 01 J 61/30**
① Application number: **85850298.2**
② Date of filing: **25.09.85**

④ **Compact low-pressure mercury vapour discharge lamp incorporating a mercury condensation chamber.**

③ Priority: **23.05.85 SE 8502562**

④ Date of publication of application:
03.12.86 Bulletin 86/49

④ Publication of the grant of the patent:
07.03.90 Bulletin 90/10

④ Designated Contracting States:
AT BE CH DE FR GB IT LI LU NL SE

⑤ References cited:
DE-B-1 539 504
GB-A- 398 799
US-A-4 173 730

PATENT ABSTRACTS OF JAPAN, E-section, Vol.
9, no. 240, September 26, 1985

⑦ Proprietor: **Lumalampan Aktiebolag**
P.O. Box 508
S-371 23 Karlskrona (SE)

⑦ Inventor: **Björkman, Ake**
Hortensvägen 26
S-371 45 Karlskrona (SE)

⑦ Representative: **Erixon, Bo et al**
Kooperativa Förbundet (KF) Patent Department
Box 15200
S-104 65 Stockholm (SE)

Note: Within nine months from the publication of the mention of the grant of the European patent, any person may give notice to the European Patent Office of opposition to the European patent granted. Notice of opposition shall be filed in a written reasoned statement. It shall not be deemed to have been filed until the opposition fee has been paid. (Art. 99(1) European patent convention).

Description

The present invention relates to a so-called compact low-pressure mercury vapour discharge lamp, i.e. a gas discharge lamp, comprising two or more mutually parallel tubes which are joined together in the proximity of their ends by interconnecting means to form a common discharge chamber between two electrodes placed in the mutually opposite, furthest ends of the discharge chamber. These ends are connected in a gas-tight manner to a common lamp base which incorporates a starter or ignition means and the requisite series impedance means, and is provided with contact pins for current supply to the lamp. The interconnecting means have an elliptical cross-section. Such a lamp is known from JP—A—60—91549.

Many kinds of compact low-pressure mercury vapour discharge lamps are known to the art. Of these many known designs, there are two constructions which dominate in the case of lamps comprising solely two straight tubes. The first of these constructions can be most easily described as being of inverted U-shape, with the lamp electrodes located in the free ends of the tube, these free ends being attached to a common lamp base. The second of these dominating lamps has a substantially H-shape, with the horizontal bridge placed at a very high location between the two verticals. In this lamp, the electrodes are arranged in the tube ends located furthest from the bridge. The ends of the tubes in which the electrodes are located are also fitted to a common lamp base, which incorporates a starter or ignition means and series impedance means. The tubes of both these designs are coated internally with a luminous powder of any desired composition. This luminous powder converts the ultraviolet light rays produced by a discharge into visible light.

Those compact low-pressure mercury discharge lamp variants which incorporate more than two straight tubes normally comprise four tubes. These tubes may be located in a single plane, or may be placed in the corners of a square, forming an imaginary cross-section at right angles to the symmetry axes of the tubes. Cross-coupling between the straight tubes is effected alternately between the tube ends located furthest away from the lamp base and the tube ends located nearest said base. Only the first and the last tubes, together with other tubes and the cross-coupling tubes forming a common discharge chamber, are connected to the lamp base, and it is in these ends of the base connected tubes that the electrodes are arranged. In this way there is formed a continuous discharge chamber through which the electric current passing between the electrodes flows when the lamp is energized. The fact that electric current is forced to change direction when passing from one straight tube to another straight tube, via an interconnected tube, has no essential significance with respect to luminous efficiency.

In compact low-pressure mercury vapour discharge lamps, as with other low-pressure gas discharge lamps, there is formed between the electrodes a positive column of light arc which passes through a rare gas mixed with mercury vapour. The gas pressure in a compact gas-discharge lamp is held beneath 500 Pascal (Pa), and at operating temperatures the mercury partial pressure constitutes less than 1 Pa of this value.

The function of the rare gas is to facilitate lamp ignition at a reasonable start voltage, and to increase the probability of collision between the electrons and mercury atoms when the lamp is energized. The low mercury vapour pressure prevailing at 40°C provides the optimum for producing the mercury resonance lines, which lie within the ultraviolet range, namely at 253.7 and 185 nanometers (nm). Of the light thus produced the longer wavelength is responsible for 85% of the intensity, whereas the shorter wavelength constitutes 15%. If a low-pressure mercury vapour discharge lamp were to contain solely mercury vapour, the electrons would collide practically solely with the tube walls and mercury atoms, wherewith in the absence of luminous powder the electron energy would be converted into heat and not into light. Many of the collisions with mercury atoms would result in an elastic effect, causing the energy of the electrons to be absorbed without exciting the photons.

A compact low-pressure mercury vapour discharge lamp of the aforescribed U-configuration is known from EP—A—2—0 061 758. It is stated in this publication that the object of the invention described therein is to provide a lamp in which the glass walls thereof have such a geometric configuration that certain parts thereof sustain a desirably low temperature during operation of the lamp, so that mercury is able to condense in the vicinity of these parts. A balanced mercury vapour pressure is obtained in the lamp in this way.

Another compact discharge lamp of U-shape having the features as described in the first part of Claim 1 is the result of the method described in JP—A—60—91549 (appl. No. 58—199718). This lamp shows interconnecting means having a cross-section of elliptical shape.

In DE—B—1539504 an ordinary low-pressure mercury vapour discharge lamp is described having shields in front of its cathodes. These shields minimize the radio disturbance frequencies radiated from the cathodes, but do not range over the whole cross-section of the tubes.

The object of the present invention is to provide a compact low-pressure mercury vapour discharge lamp in which the mercury partial pressure in the discharge chamber, during operation of the lamp, is maintained at the level which affords maximum power with respect to the formation of radiation by the discharge in the mercury resonance lines.

A further object is to screen the lamp electrodes so as to limit the extent to which heat generated thereby propagates. It is ensured hereby that the

temperature of a major part of the straight tubes at the ends thereof located furthest from the lamp base will not exceed 40°C. This is of particular importance when such compact low-pressure mercury vapour lamps are placed in lamp fittings provided with reflectors. When the lamps are housed in lamp fittings in this nature, the heat emitted by the lamps is not adequately dissipated and temperatures in excess of 40°C occur within the lamps. This causes the mercury vapour pressure in the lamp to rise, resulting in a lower intensity in the generation of radiation in the mercury resonance lines.

These objects are achieved by means of the invention defined and characterized in the following claims.

The invention is based on the concept that in a discharge chamber of the kind used in compact low-pressure mercury vapour lamps the negative space charge is concentrated to the tube walls and a positive column is formed between the electrodes with the space charge 0 along its axis. The discharge between the cathode and anode regions is unitary in the axial direction at each moment following ignition of the lamp. Positive ions and electrons are formed simultaneously with the discharge. These are concentrated at the tube walls by diffusion. Since the column is axially unitary, no particle losses are experienced in the axial direction. During this diffusion process, the electrons move much more rapidly than the positive ions, due to the smaller mass of the electrons, and hence a positive space charge is developed from the centre of the tube outwards. This combined diffusion of both sorts of charge carriers is called ambipolar diffusion. This improves conditions for discharge in the positive column, and therewith increases the power in the ultraviolet radiation.

In order to enable the discharge to propagate naturally in the lamp, this propagation wave being of circular cross-section, the novel compact low-pressure mercury vapour lamp is provided with a mercury condensation section which extends along a part of the positive column, without encroaching upon the column, either axially or radially. This prevents disturbances of the circular propagation wave of the positive column, which is a requisite for optimum radiation generation by the discharge. This condensation section is obtained in practice by giving the lamp discharge chamber a U-shape, wherewith the peripheral surface of the curved tube section between two straight tube members is drawn from its circular cross-sectional shape into a spine-like configuration in the region of the tube section of largest radius of curvature. This spine extends along substantially the whole of the curved tube section.

The spine extending along the U-bend of the lamp suitably has an angle of 90° or therebelow, when seen in cross-section. In this way there is formed in the tube bend a space which lies to one side of the positive column and in which the mercury condensation temperature can be held

constant at the pressure prevailing in the lamp. Expressed differently it can be said that the length of the lamp at different wattages is chosen so that the temperature prevailing along the spine when the lamp operates at normal room temperatures is in the vicinity of 40°C, this temperature being liable to be in excess of 70°C in the region nearest the electrodes. Consequently, the mercury partial pressure will be beneath 1 Pa, or about 5×10^{-3} torr, which is the pressure at which the relative efficiency for the generation of resonance radiation in mercury vapour from a light arc culminates. At lower mercury partial pressures the mercury atoms are spaced too widely apart, resulting in fewer collisions between the atoms and electrons and hence also in fewer excited photons of a low intensity in the ultraviolet radiation. At higher mercury vapour partial pressures, the mercury atoms are so dense that the number of collisions becomes excessive and electrons rebound, which also results in fewer excited photons.

The method by which the thermal propagation from the electrodes is restricted in accordance with the invention involves providing the straight tubes with screening elements downstream of the electrodes. It has been found that such an arrangement surprisingly increases the useful life span of the lamp manifold. It has been established that this is because the reduction in the free area of the glass tubes downstream of the electrodes in the path of the discharge current causes the electron density to increase during the half period over which the electrode functions as an anode. Consequently, the anode drop is reduced, resulting in a lower temperature of the emission substance with which the electrode is coated. This reduced temperature lowers the rate at which the emission substance vapourizes. This in turn results in an increase in the useful electrode life and therewith also in the useful life span of the lamp.

An important contribution to the increase in the useful life span of the electrode is given by the reflection of vapourized emission substance taking place in the screened space around the electrode, this space being defined by the screening element downstream thereof. Those emission substance ions released from the electrode surface during one half period have very limited possibility of moving in the axial direction of the positive column generated in the lamp. The screening element causes the positive column to be compressed radially, whereby only a minimum negative space charge exists along the tube wall adjacent the actual screening element or plate. Consequently, the released ions remain in the constricted space nearest the electrode, and fall back on the electrode surface during the next half period.

The ions released from the emission substance have a far greater mass than the electrons around the electrode and consequently move much more slowly. As a result, the ions do not reach the tube wall to any appreciable extent before the dis-

charge current changes direction, and do not therefore precipitate onto the glass wall, which would otherwise be blackened.

In addition to this screening of the straight tubes downstream of the electrodes resulting in reflection of the emission substance, thereby greatly restricting its degradation, it also reduces the occurrence of emission substance ions in the discharge chamber. Since a part of this chamber can be maintained at a temperature of 40°C, the mercury vapour pressure will be beneath 1 Pa, or approximately 5×10^{-3} torr, which is the pressure at which the relative efficiency for the generation of resonance radiation in mercury vapour from a light arc culminates. At lower mercury partial pressures the mercury atoms are spaced too widely apart, resulting in fewer collisions between the atoms and electrons and hence also in fewer excited photons or a lower intensity in the ultraviolet radiation. At higher mercury partial pressures, the mercury atoms are so dense that the number of collisions becomes excessive and electrons will rebound, which also results in fewer excited photons. Consequently, the low ion content from the emission substance results in the loss of but very few electrons through collision with such ions. Thus, a large number of electrons collide with mercury atoms, resulting in high efficiency, i.e. a high luminous efficiency for each Watt applied. Measurements have shown that the luminous flux of a compact low-pressure mercury vapour discharge lamp according to the invention is 3.5 times per Watt greater than that achieved with prior art lamps of this kind.

A preferred embodiment of a compact low-pressure mercury vapour discharge lamp will now be described with reference to the accompanying drawings, in which

Figure 1 is a partly cut-away view of the compact low-pressure mercury vapour discharge lamp;

Figures 1A and 1B are cross-sectional views of the lamp on both sides of the screening element;

Figure 1C is a longitudinal sectional view of one electrode region in the lamp, illustrating the positioning of the screening element;

Figure 2 illustrates schematically the curved interconnecting part of the lamp, indicating a conceivable spine angle; and

Figure 3 is a diagram showing the relative efficiency for generating resonance radiation in mercury as a function of the lowest temperature within a discharge lamp (bottom scale) and a corresponding mercury vapour pressure (top scale).

The compact low-pressure mercury vapour discharge lamp 1 comprises two straight tubes 2, 3, which are internally coated with a luminescent powder of the two or three band type, and which are interconnected by an arcuate tube 4 located at a distance from the ends 5, 6 of the straight tubes 2, 3. The ends 5, 6 are connected in a gas-tight manner to a common lamp base 7. The lamp base is provided on the side thereof remote from the tubes 2, 3 with a housing 8 which encloses a

starter and series impedance means. Located on both sides of the housing 8 are contact pins 9, 10 for supply of current to the lamp 1.

Formed in the glass walls of the tubes 2, 3 at mutually different levels 11, 12 adjacent the ends 5, 6 of said tubes are depressions which extend towards the centre of the tubes with a height of less than 1 mm. Plates 13 made of an electrically non-conducting material are snapped into the depressions. The plates 13 may be made, for example, of mica and have a thickness varying between 0.10 and 0.20 mm.

The following description in respect of the Fig. 1 embodiment will be made solely with reference to the one straight tube 3. The plate 13 snapped into this tube has a centrally located aperture, which may have a diameter of from 4.0 to 8.0 mm, calculated in respect of an internal tube diameter of 10 mm. With a tube of this diameter, the plate 13 is located at a distance of 3—10 mm downstream from the electrode 14 located in the tube 3. The electrode 14 is carried by two conductors 15 fused into a glass stem 16. The glass stem is, in turn, fused gas-tight with the end 6 of the tube 3. The one conductor 16 is connected to the contact pin 10 and the other to the starter in the housing 8.

The lamp is normally filled with the rare gas argon to a pressure of approximately 400 Pa (3 torr). When the aperture in the plate 13 is smaller than 4 mm, the glow voltage of the lamp 1 will increase, which is not to be desired. It has been found that this can be counteracted by adding krypton to the rare gas filling. Since krypton is an extremely expensive gas, it is desirable to minimize the amount added. Although a krypton addition of between 70 and 90% will afford an extraordinarily good effect, it does not mean that a high krypton content of the rare gas filling will enable the diameter of the orifice in the plate 13 to be further decreased.

The purpose of providing a small aperture in the plate 13 is to define a space around the electrode 14 in the best possible manner. There is provided in this way an isolated space for ions released from the emission substance with which the electrode 14 is coated. These ions are primarily barium ions which are thrown out in the region nearest the electrode 14 during operation of the lamp. The smaller the diameter of the orifice in the plate 13, the more concentrated in cross-section is the positive column formed between the lamp electrodes. Since ion movement in the axial direction of the positive column is practically excluded, the possibility for ions released from the emission substance to leave the space around the electrode 14 is greatly impeded. Since the current changes phase in the next half period, practically all of these ions will fall back onto the surface of the electrode 14, which thereby retains sufficient emission substance to function satisfactorily for at least 15000 operational hours. No measurable degradation of the fluorescent layer 17 on the inner surfaces of the tube 2—4—3 takes place during this time. Neither is the rare gas

filling affected during this long length of useful lamp life, irrespective of whether the filling is pure argon or argon admixed with other rare gases, for example 10—25% neon or 70—90% krypton. As will be seen from the diagram in Fig. 3, it is of supreme interest to maintain in the lamp a mercury vapour pressure of 0,667 Pa (5×10^{-3} torr). This corresponds to a temperature of close to 40°C. Thus, some part of the lamp must be heated to this temperature in order to obtain optimum radiation generation in the mercury resonance lines. Normally, the temperature in the electrode region of the lamp is in the order of 70°C. By providing the interconnecting tube 4 with a spine 18 which deviates from the circular cross-sectional shape of the tube and which extends along a substantial part of the outer curved surface of the interconnecting tube 4, there is obtained a space in which the temperature 40°C can be maintained constant while the lamp is energized. An extremely high concentration of negative space charge namely occurs along the spine 18. This means that the positive column between the lamp electrodes will in no way endeavour to depart from its natural circular cross-section. Since the light arc generated by the discharge current is therefore contained within the circular cross-section and heated ions are repelled radially from the negative space charge in the spine 18, it is possible to maintain the aforesaid temperature of 40°C within the spine. The spine 18 is given an acute angle, in order to obtain an effect which can be likened to a cooling-fin effect. It has been found in practice that technical difficulties occur in production when attempting to produce a spine angle more acute than 60°. Neither is it necessary to provide an angle more acute than 60°, since a spine angle of 90° affords a sufficiently low temperature in the space along the spine 18.

The compact low-pressure mercury vapour discharge lamp has been described with reference to its simplest variant, i.e. a lamp comprising two mutually parallel tubes. A compact low-pressure mercury vapour discharge lamp according to the invention, however, can be produced with any number of straight tubes. In the case of lamps which comprise more than two straight tubes, the tubes connecting the straight tubes and corresponding to the interconnecting tube 4 may all be provided with a spine 18, similar to said interconnecting tube. Despite this, however, it suffices to provide solely one of the interconnecting tubes with a spine 18 where mercury vapour condensation can occur, and thus maintain the desired mercury vapour pressure in the lamp.

Since it is desirable to use only one lamp base with a compact low-pressure mercury vapour discharge tube, the lamp suitably comprises a uniform number of mutually parallel straight tubes. In such cases the straight tubes are connected by couplings corresponding to the tube 4 alternately between the ends of two straight tubes located furthest from the lamp base 7 and the ends of the tubes located nearest the lamp base.

The straight tubes are given a length adapted to the wattage for which the lamp is intended.

Claims

1. A compact low-pressure mercury vapour discharge lamp comprising two or more mutually parallel, straight tubes (2, 3) arranged side by side, each tube having first and second (5, 6) ends, the tubes being connected together at their first ends by interconnecting means (4) having a non-circular cross-section, to form a continuous serpentine discharge chamber extending between two electrodes placed in the ends of the discharge chamber, said ends (5, 6) being connected to a common lamp base (7) enclosing a starter and series impedance means, characterized in that downstream from the electrodes in the discharge path the straight tubes (2, 3) are provided in the vicinity of the said ends (5, 6) with plates (13) of an electrically non-conductive material, said plates having a central aperture and ranging over the whole cross-section of the straight tubes (2, 3), and defining spaces near the said electrodes (14), whereby the plates, through their apertures, concentrate radially the positive column present between said electrodes when the lamp is energized.

2. A lamp according to Claim 1, characterized in that the aperture in each plate (13) has a diameter equal to 30%—80% of the diameter of the straight tubes (2, 3), preferably 40%—50% of said diameter.

3. A lamp according to Claim 1 or Claim 2, characterized in that the interconnection (4) between two straight tubes (2, 3) is provided with a spine (18) which extends along said interconnection on its side remote from the lamp base.

4. A lamp according to Claim 3, characterized in that the spine (18) exhibits in cross-section an acute angle of between 60° and 90°, preferably 70°—80°.

5. A lamp according to any one of the preceding claims, characterized in that the plates (13) are mica plates and are arranged downstream from the electrodes (14).

6. A lamp according to Claim 1 or Claim 5, characterized in that the plates (13) are held fixed at a distance downstream from the electrodes (14) of 0.3—1.0 times the diameters of the tubes (2, 3), by snap-in connection between depressions (11, 12) in the glass walls of the straight tubes (2, 3).

7. A lamp according to any one of the preceding claims, characterized in that the electrodes (14) are coated with an emission substance from which barium ions are released when the lamp is energized.

8. A lamp according to any one of the preceding claims, characterized in that the lamp is filled with a rare gas filling to approximately 500 Pa pressure, preferably pure argon.

9. A lamp according to any one of Claims 1—7, characterized in that the lamp has a rare gas filling comprising at least 10% argon and at most 90% krypton.

10. A lamp according to any one of the preceding claims, characterized in that it contains mercury which, when the lamp is energized, vapourizes to a partial pressure of between 0,533 Pa (4×10^{-3} torr) and 1 Pa (7.5×10^{-3} torr).

Patentansprüche

1. Kompakte Niederdruck-Quecksilberdampfentladungslampe mit zwei oder mehr wechselseitig parallelen geraden Röhren (2, 3), die nebeneinander angeordnet sind, wobei jede Röhre erste und zweite (5, 6) Enden aufweist, wobei ferner die Röhren miteinander an ihren ersten Enden verbunden sind durch Verbindungsmittel (4), die einen nicht-kreisförmigen Querschnitt haben, um eine kontinuierliche abgeboogene Entladungskammer zu bilden, die sich zwischen zwei Elektroden erstreckt, welche in den Enden der Entladungskammer angeordnet sind, wobei diese Enden (5, 6) mit einem gemeinsamen Lampenfuß (7) verbunden sind, der einen Anlasser und Reihenimpedanzen enthält, dadurch gekennzeichnet, daß stromabwärts von den Elektroden in der Entladungsbahn die geraden Röhren (2, 3) in der Nähe dieser Enden (5, 6) mit Platten (13) aus einem elektrisch nicht-leitenden Material versehen sind, daß diese Platten eine zentrale Öffnung haben und sich über den gesamten Querschnitt der geraden Röhren (2, 3) erstrecken, und daß Räume nahe diesen Elektroden (14) gebildet werden, wodurch die Platten mittels ihrer Öffnungen die positive Säule radial konzentrieren, die zwischen den Elektroden vorhanden ist, wenn die Lampe erregt ist.

2. Lampe nach Anspruch 1, dadurch gekennzeichnet, daß die Öffnung in jeder Platte (13) einen Durchmesser hat, der 30%—80% des Durchmessers der geraden Röhren (2, 3), vorzugsweise 40%—50% dieses Durchmessers beträgt.

3. Lampe nach Anspruch 1 oder 2, dadurch gekennzeichnet, daß das Verbindungsstück (4) zwischen zwei geraden Röhren (2, 3) mit einem Rücken (18) versehen ist, der sich längs des Verbindungsstückes auf dessen Seite entfernt vom Lampenfuß erstreckt.

4. Lampe nach Anspruch 3, dadurch gekennzeichnet, daß der Rücken (18) im Querschnitt einen spitzen Winkel von zwischen 60° und 90° vorzugsweise 70° — 80° aufweist.

5. Lampe nach einem der vorhergehenden Ansprüche, dadurch gekennzeichnet, daß die Platten (13) aus Glimmer bestehen und stromabwärts von der Elektroden (14) angeordnet sind.

6. Lampe nach Anspruch 1 oder 5, dadurch gekennzeichnet, daß die Platten (13) in einem Abstand stromabwärts von den Elektroden (14) festgehalten sind, der das 0,3—1,0 fache des Durchmessers der Röhren (2, 3) beträgt, mittels einer Einschnapp-Verbindung zwischen Vertiefungen (11, 12), in den Glaswänden der geraden Röhren (2, 3).

7. Lampe nach einem der vorhergehenden Ansprüche, dadurch gekennzeichnet, daß die

Elektroden (14) mit einer Emissions-Substanz beschichtet sind, aus der Barium Ionen freigegeben werden, wenn die Lampe erregt ist.

8. Lampe nach einem der vorhergehenden Ansprüche, dadurch gekennzeichnet, daß die Lampe mit einer Edelgasfüllung gefüllt ist auf einen Druck von etwa 500 Pa, vorzugsweise mit reinem Argon.

9. Lampe nach einem der Ansprüche 1—7, dadurch gekennzeichnet, daß die Lampe eine Edelgasfüllung hat, die wenigstens 10% Argon und höchstens 90% Krypton enthält.

10. Lampe nach einem der vorhergehenden Ansprüche, dadurch gekennzeichnet, daß sie Quecksilber enthält, das, wenn die Lampe erregt ist, verdampft auf einen Partialdruck von zwischen 0,533 Pa (4×10^{-3} Torr) und 1 Pa ($7,5 \times 10^{-3}$ Torr).

Revendications

1. Lampe à décharge compacte, à vapeur de mercure à basse pression, comprenant au moins deux tubes droits (2, 3) parallèles entre eux, disposés côte à côte, chaque tube ayant une première extrémité et une deuxième extrémité (5, 6), les tubes étant reliés ensemble sur leurs premières extrémités par des moyens d'interconnexion (4) ayant une section transversale non circulaire, pour former une chambre de décharge continue et sinueuse s'étendant entre deux électrodes placées dans les extrémités de la chambre de décharge, lesdites extrémités (5, 6) étant reliées à un culot de lampe (7) commun renfermant un starter et un moyen d'impédance en série, caractérisée en ce que, en aval à partir des électrodes dans le trajet de la décharge, les tubes droits (2, 3) sont munis, au voisinage desdites extrémités (5, 6), de plaques (13) faites d'un matériau non conducteur de l'électricité, ayant une ouverture centrale et s'étendant sur toute la section transversale des tubes droits (2, 3), et délimitant des espaces près desdites électrodes (14), grâce à quoi les plaques, par leurs ouvertures, concentrent radialement la colonne positive présente entre lesdites électrodes quand la lampe est excitée.

2. Lampe selon la revendication 1, caractérisée en ce que l'ouverture dans chaque plaque (13) a un diamètre compris entre 30% et 80% du diamètre des tubes droits (2, 3), de préférence entre 40% et 50% dudit diamètre.

3. Lampe selon la revendication 1 ou 2, caractérisée en ce que l'interconnexion (4) entre deux tubes droits (2, 3) est munie d'une arête (18) qui s'étend le long de ladite interconnexion sur son côté éloigné du culot de la lampe.

4. Lampe selon la revendication 3, caractérisée en ce que l'arête (18) présente, vue en coupe transversale, un angle aigu compris entre 60° et 90° , de préférence entre 70° et 80° .

5. Lampe selon l'une quelconque des revendications précédentes, caractérisée en ce que les plaques (13) sont des plaques en mica et sont disposées en aval des électrodes (14).

6. Lampe selon la revendication 1 ou la revendication 5, caractérisée en ce que les plaques (13) sont maintenues fixes à une distance, en aval à partir des électrodes (14) comprise entre 0,3 et 1,0 fois les diamètres des tubes (2, 3), par une connexion à encliquetage entre des dépressions (11, 12) dans les parois en verre des tubes droits (2, 3).

7. Lampe selon l'une quelconque des revendications précédentes, caractérisée en ce que les électrodes (14) sont revêtues d'une substance émissive à partir de laquelle se dégagent des ions baryum quand la lampe est excitée.

8. Lampe selon l'une quelconque des revendi-

cations précédentes, caractérisée en ce que la lampe est remplie d'un remplissage de gaz rare sous une pression d'approximativement 500 Pa, de préférence en argon pur.

9. Lampe selon l'une quelconque des revendications 1 à 7, caractérisée en ce que la lampe a un remplissage de gaz rare comprenant au moins 10% d'argon et au plus 90% de krypton.

10. Lampe selon l'une quelconque des revendications précédentes, caractérisée en ce qu'elle contient du mercure qui se vaporise, quand la lampe est excitée, à une pression partielle comprise entre 0,533 Pa (4×10^{-3} torr) et 1 Pa ($7,5 \times 10^{-3}$ torr).

5

10

15

20

25

30

35

40

45

50

55

60

65

7

Fig. 1

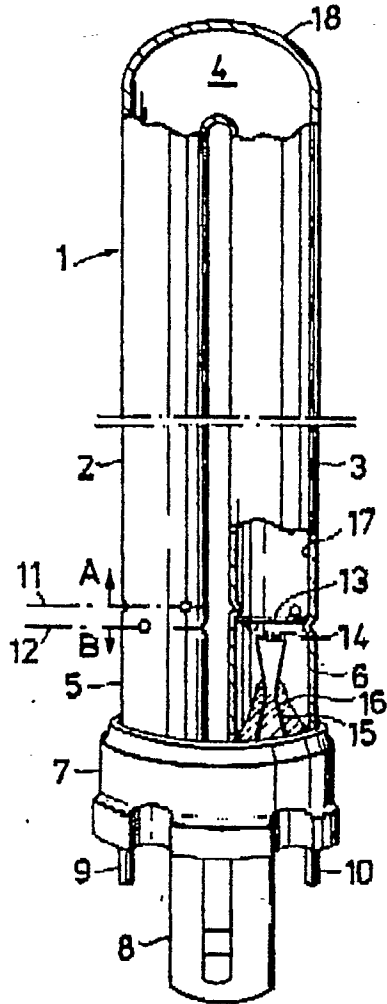

Fig. 1A

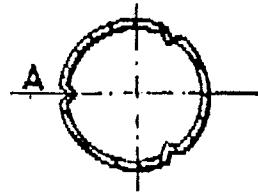

Fig. 1B

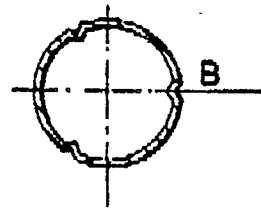
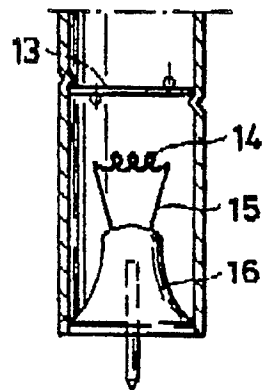

Fig. 1C



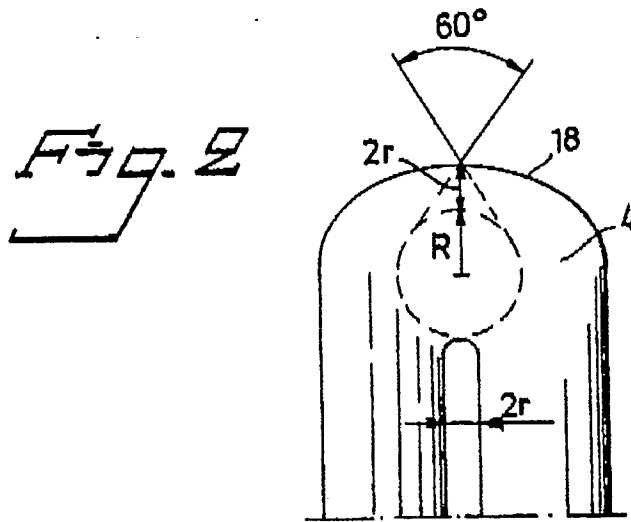

Fig. 3

