

Aug. 25, 1925.

1,551,434

D. B. SHIFFER

TOILET ACCESSORY

Filed Sept. 5, 1924

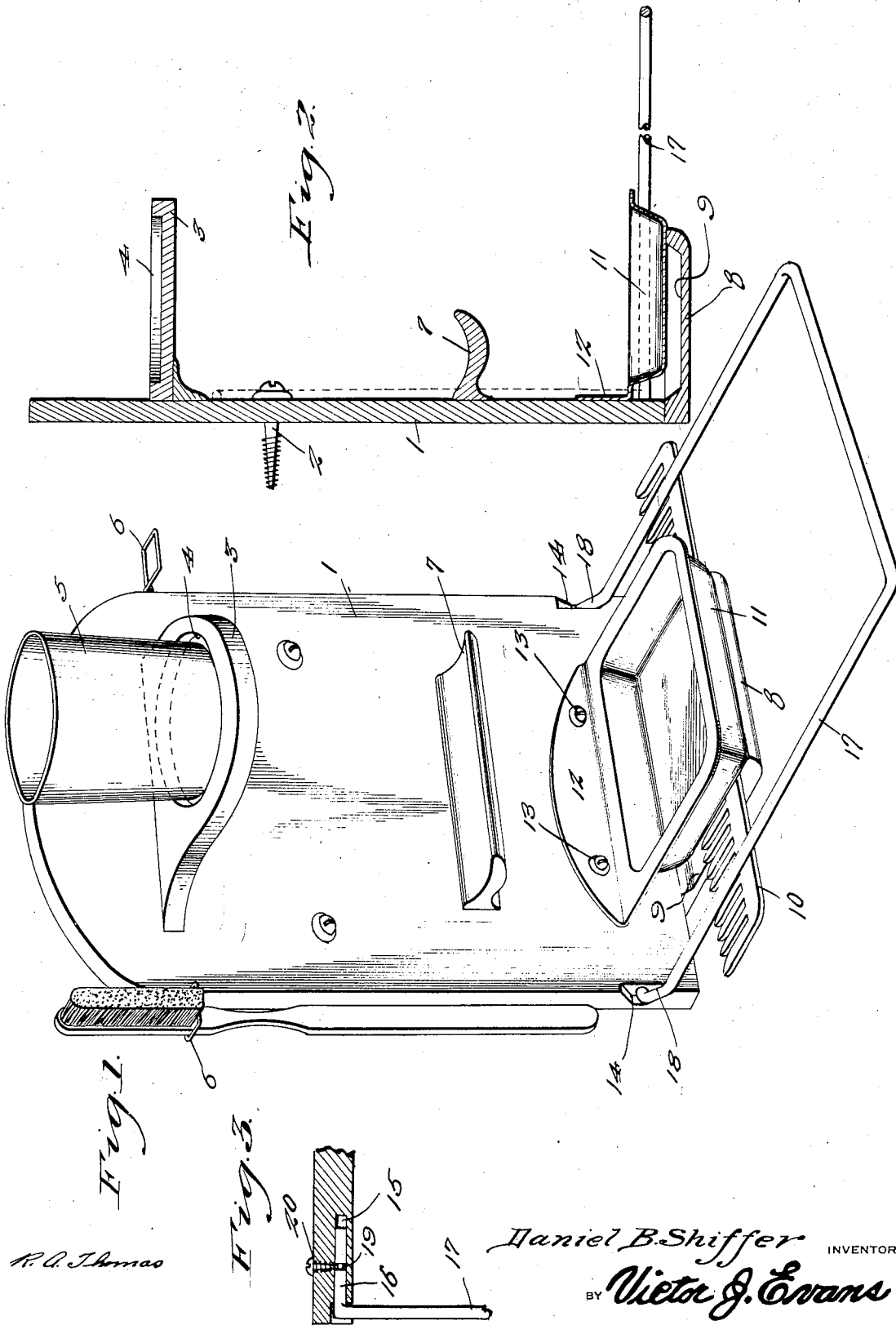

Fig. 1.

Fig. 2.

Fig. 3.

R. Q. Thomas

WITNESS

Daniel B. Shiffer INVENTOR

BY Violet J. Evans

ATTORNEY

UNITED STATES PATENT OFFICE.

DANIEL B. SHIFFER, OF MANHEIM, PENNSYLVANIA.

TOILET ACCESSORY.

Application filed September 5, 1924. Serial No. 736,104.

To all whom it may concern:

Be it known that I, DANIEL B. SHIFFER, a citizen of the United States, residing at Manheim, in the county of Lancaster and State of Pennsylvania, have invented new and useful Improvements in Toilet Accessories, of which the following is a specification.

My present invention has reference to a toilet accessory.

My primary object is the provision of a cheaply constructed and easily attached device of a compact nature and provided with means for supporting thereon, a comb, a cake of soap, a tube of tooth paste, a glass or tumbler, tooth brushes or nail brushes and a wash cloth or towel, the last mentioned means being swingable and self supporting when in extended position or when folded against the body of the improvement.

A further object is the provision of a device for this purpose which shall be of an ornamental nature and which is characteristic of simplicity in construction and cheapness in manufacture whereby the same may be marketed with a profit at a low cost.

With the above recited objects in view and others, which will appear as the nature of the invention is better understood, the improvement resides in the construction, combination and operative association of parts such as is disclosed by the drawings and set forth in the appended claims.

In the drawings:—

Figure 1 is a perspective view of the improvement.

Figure 2 is a substantially central vertical longitudinal sectional view therethrough.

Figure 3 is a fragmentary horizontal sectional view through the body of the improvement to disclose the manner in which the arms of the towel rack are supported for turning therein.

All of the parts of my improvement, excepting the securing means, the soap tray, the yoke support for the brushes and the cloth or towel rack are preferably of wood suitably enameled to add to the ornamentality of the device, while the metal parts are preferably of aluminum and are nicked to present a pleasing effect.

The wooden body of the improvement is indicated by the numeral 1, and as disclosed in Figure 1 of the drawings is provided with two spaced openings for screws 2 that attach the body to the wall of a bathroom or

to any other suitable support. The heads of the screws engage with washers to prevent injury to the body.

The top of the body 1 is rounded to add to the ornamentality thereof, and at a suitable distance below the top there is secured on the body 1 an outstanding flange providing a shelf 3. The outer wall of the shelf is rounded and the sides thereof are concaved to the rear edges at the straight inner end of the said shelf. The top of the shelf is formed with a round depression 4 for the reception of a tumbler 5.

The sides of the body, approximately in a line with the shelf 3 has connected thereto outstanding yokes 6 through which the handles of nail and tooth brushes are passed, the bristles of the said brushes resting on the yokes.

At a suitable distance below the shelf 3 there is secured on the body 1 a strip of molding whose upper face is concaved. The molding provides a ledge 7 on which a tube of tooth paste is designed to be supported.

The lower edge of the body has attached thereto, at points inward of the sides thereof, an outwardly directed flange 8, and the upper wall of this flange is grooved longitudinally as at 9. The flange provides a seat for a comb 10, and the said comb is prevented from upward movement by virtue of the arrangement of a soap tray 11 directly above the flange 8. The tray 11 rests on the upper and outer edge of the grooved flange 8, while the inner wall of the said tray is flanged upwardly as at 12, and is provided with spaced slots through which are passed screws 13 that enter the body 1. The heads of these screws contact with washers.

The sides of the body 1, at a suitable distance from the lower portion of the said body, are formed with substantially V-shaped notches 14, but the inner walls of these notches are straight. The side walls provided by the notches are grooved, as at 15 to provide pockets for the inner angle ends 16 of a U-shaped wire member 17 that provides a cloth or towel support. The sides thereof with the ends 16, are angularly disposed as at 18. These angle portions 18 will rest on the lower walls of the V-shaped notches 14 when the support 17 is in horizontal position as disclosed in Figures 1 and 2 of the drawings, and the said angle por-

tions will likewise contact with the upper walls of the notches when the support 17 is swung against the body 1. In this connection it is to be stated that the arms of the substantially U-shaped support 17 exert a pressure toward each other so that the said support will be self-sustaining in its inoperative position. To more effectively brace the support in either its operative or inoperative positions, the ends 16 of the said support are provided with annular grooves 19, and the said grooves are engaged by the ends of adjustable elements in the nature of screws 20 that pass through the rear of the body 1. The screws 20 may exert a frictional engagement against the inner wall of the groove 19, and the said screws also prevent the ends 16 of the support being moved out of the grooves 19.

The improvement is of a small and compact nature which may be readily attached to a support without injury thereto. The device presents a useful, durable, ornamental and sanitary article for bedroom, bathroom, kitchen, etc. The improvement supports in relative association toilet articles which are ordinarily scattered around a bathroom or the like or which are separately supported in such room so that with its use a large amount of room space is saved and the marring of the walls incident to the insertion therein of various toilet article supporting means is overcome.

Having described the invention, what I claim is:—

1. In a device for the purpose set forth, a flat body having outstanding means thereon for supporting various toilet articles, said body having its edges, adjacent its bottom formed with V-shaped notches, a bail-shaped towel support of resilient material having offset ends pocketed in the body in a line

with the said notches, and the sides of the support, at the juncture of the angle ends thereof being angularly disposed for contacting engagement with the opposite walls of the notches when the support is swung against or at an outward angle on the body.

2. In a device for the purpose set forth, a flat body having outstanding means thereon for supporting various toilet articles, said body having its edges, adjacent its bottom formed with V-shaped notches, a bail-shaped towel support of resilient material having offset ends pocketed in the body in a line with the said notches, and the sides of the support, at the juncture of the angle ends thereof being angularly disposed for contacting engagement with the opposite walls of the notches when the support is swung against or at an outward angle on the body, and the sides of the said support exerting a tension toward each other.

3. In a device for the purpose set forth, a flat body having outstanding means thereon for supporting various toilet articles, said body having its edges, adjacent its bottom formed with V-shaped notches, a bail-shaped towel support of resilient material having offset ends pocketed in the body in a line with the said notches, the sides of the support, at the juncture of the angle ends thereof being angularly disposed for contacting engagement with the opposite walls of the notches when the support is swung against or at an outward angle on the body, the sides of the said support exerting a tension toward each other, and binding means between the body and the ends of the support pocketed in said body for preventing the free swinging of the support and the withdrawal thereof from the body.

In testimony whereof I affix my signature.
DANIEL B. SHIFFER.