

No. 666,001.

Patented Jan. 15, 1901.

G. M. DITTO.  
GRINDING MILL.

(Application filed Jan. 5, 1900.)

(No Model.)

2 Sheets—Sheet 1.

Fig. 1.

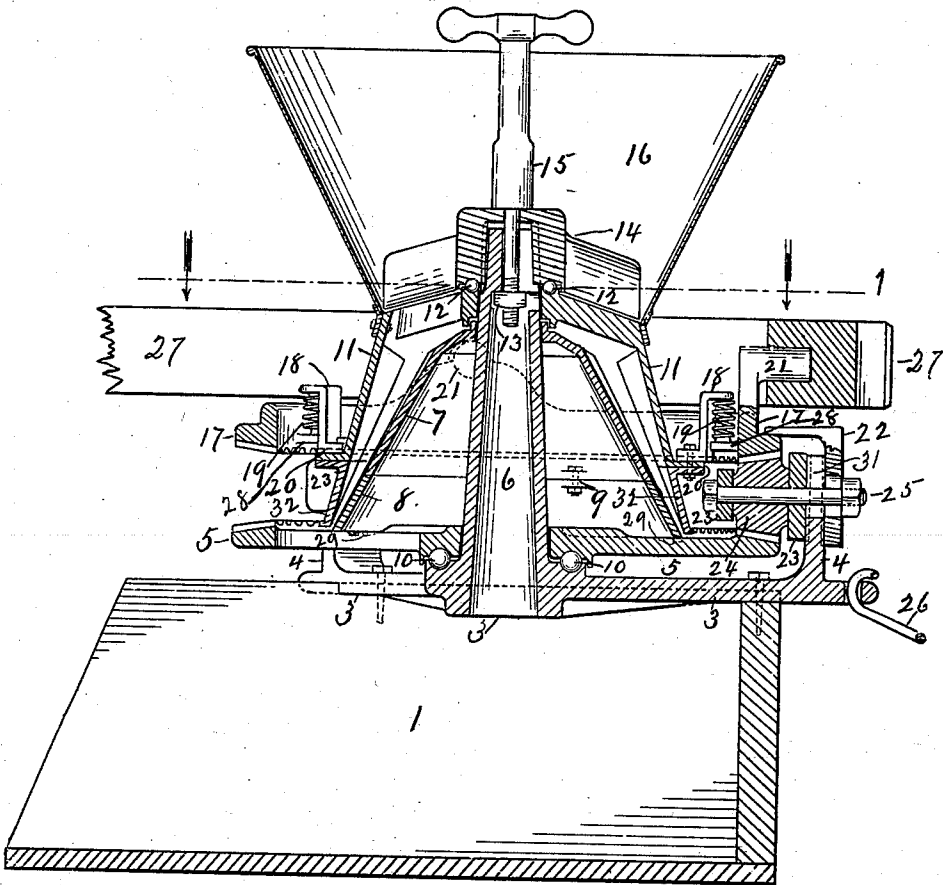
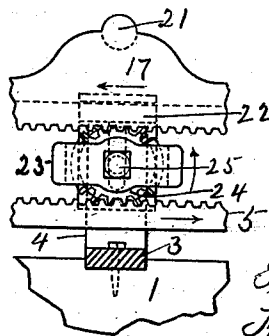

Fig. 2.



Witnesses:

Ray Hutchins  
L. B. Hutchins

Inventor:

General M. Ditto By  
Thos. H. Hutchins atty

G. M. DITTO.  
GRINDING MILL.

(Application filed Jan. 5, 1900.)

(No Model.)

2 Sheets—Sheet 2.

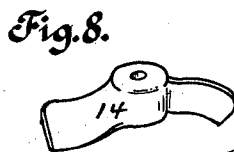
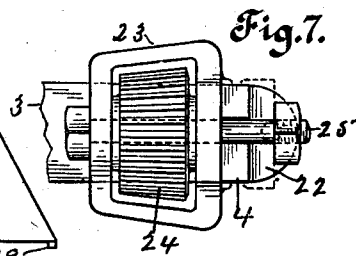
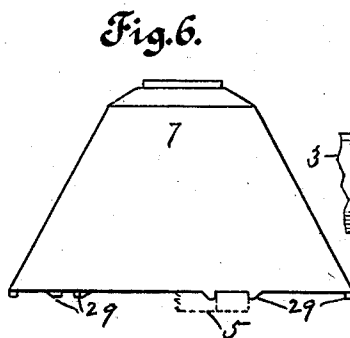
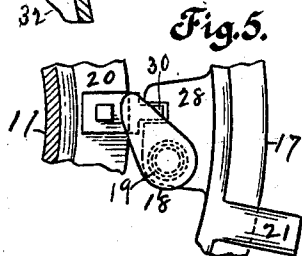
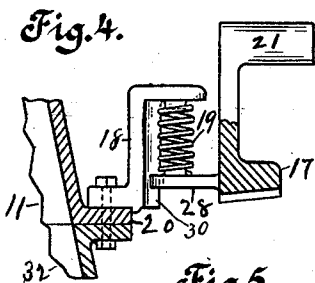
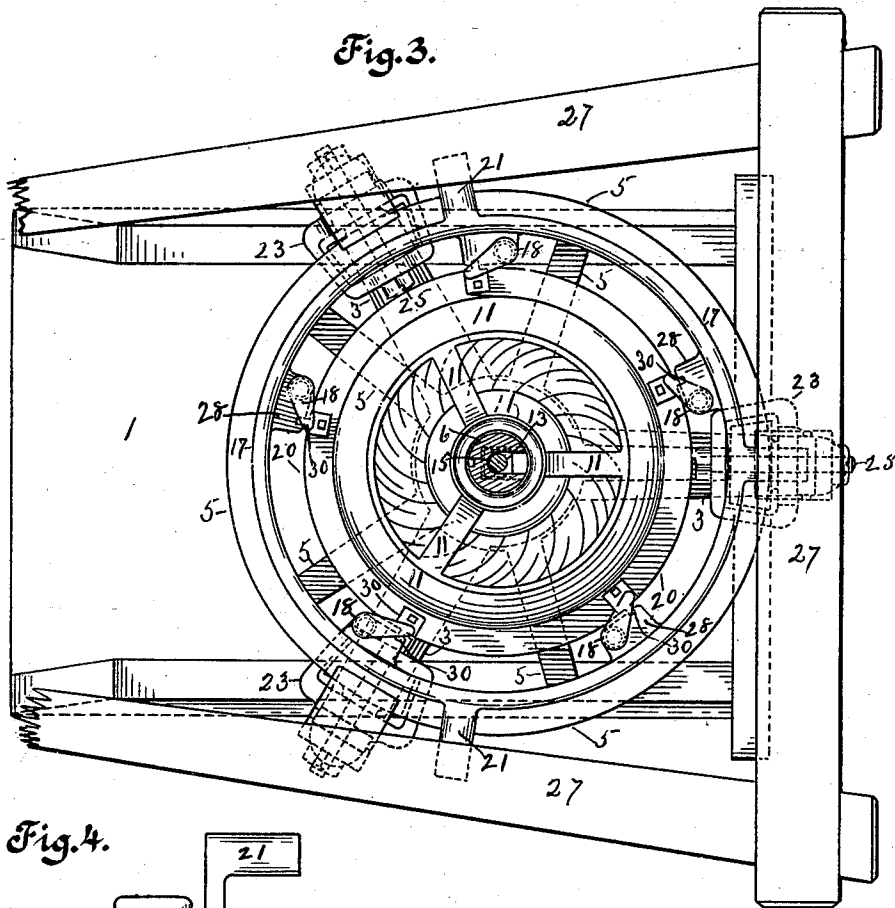

**Witnesses:**  
Ray Hutchins  
L. B. Hutchins

**Inventor:**  
General M. Ditto By  
Thos H. Hutchins atty

# UNITED STATES PATENT OFFICE.

GENERAL M. DITTO, OF JOLIET, ILLINOIS.

## GRINDING-MILL.

SPECIFICATION forming part of Letters Patent No. 666,001, dated January 15, 1901.

Application filed January 5, 1900. Serial No. 438. (No model.)

To all whom it may concern:

Be it known that I, GENERAL M. DITTO, a citizen of the United States of America, residing at Joliet, in the county of Will and State of Illinois, have invented certain new and useful Improvements in Grinding-Mills, of which the following is a specification.

This invention relates to certain improvements in grinding-mills for use more particularly in grinding ear-corn or other material for stock-feed and of the class of mills having a sweep to which a horse or other power may be attached to drive the mill, which improvements are fully set forth and explained in the following specification and claims, reference being had to the accompanying drawings, and the figures of reference thereon, forming a part of this specification, in which—

Figure 1 is a central vertical section of the mill. Fig. 2 is a detail of one of the pinions and its box and portions of the two gears with which it meshes and a cross-section of one of the arms of the stationary spider, said view being toward the inner side of the pinion. Fig. 3 is a top plan view of the machine, taken on line 1 looking in the direction of the arrows, as shown in Fig. 1. Fig. 4 is a detail view showing a section of the driving-ring and of the outer grinding-bur and a side view of a bracket attached to said grinding-bur and seated on a coil-spring resting on a projecting step integral with said driving-ring. Fig. 5 is a top plan view of Fig. 4. Fig. 6 is a side view of the inner grinding-bur, showing lugs on its lower edge for seating it on the arms of the master-wheel. Fig. 7 is a top plan view of one of the pinions and its box and a portion of the spider-arm to which said box is attached; and Fig. 8 is a perspective view of the force-feed device designed to attach to the upper end of the spindle of the spider.

Referring to the drawings, 1 represents a box for holding the ground feed. A spider 3 is secured to the top of said box, as shown in Fig. 1. Said spider has an integral central tapered hollow spindle 6, around the base of which is an annular channel for holding a series of balls 10. 5 is a master gear-wheel journaled on said spindle 6 and resting on said balls 10, thus forming a ball-bearing between said master gear-wheel and said spider. 7 8 represent an inner conical-shaped grind-

ing-bur journaled at its upper end on said spindle 6 and resting at its lower end on the spokes of the master gear-wheel 5, as shown in Fig. 1, and held in place thereon by means of its integral downwardly-projecting lugs 29 and in such manner that said grinding-bur may be rotated by means of its said attachment to said master-gear.

24 represents a series of equidistant-arranged pinions in mesh with the master-gear 5. These pinions are stationary and are attached to the standards 4, integral with the extending or outer ends of the spider-arms the boxes 23, which are adjustably secured to said standards 4 by means of a bolt 25, which forms a bearing upon which said pinions rotate. Said standards are provided with a vertical slot 31, (shown in Fig. 1,) in which said bolt may be moved vertically to adjust said pinions vertically. A nut on the outer end of said bolt furnishes means for securing it in place.

It will readily be understood that by making the bolts or journals 25 adjustable on the standards 4 less care is requisite in constructing the machine, and, moreover, the pinions are adjustable to compensate for wear.

11 32 represent the outer conical grinding-bur journaled on the spindle 6 immediately above the grinding-bur 7 8, and extends down over the inner grinding-bur in the ordinary manner. Each of said grinding-burs is provided with the ordinary grinding-teeth on their surfaces facing each other. The inner grinding-bur 7 has attached to its lower end a part 8, made of much harder material than the remainder of the bur, so it will not wear out so readily; also the outer bur is provided with a similar part 32 for the same purpose. 17 is a driving-ring having teeth on its under side at its periphery for meshing with and resting on said pinions 24. Said driving-ring is provided on its inner side with projecting steps or lugs 28 for supporting the coil-springs 19, upon which the outer grinding-bur is seated through the medium of the bracket-arms 18, secured to the flange 20 of said bur, as shown in Figs. 1, 3, 4, and 5; so that said outer grinding-bur is yieldingly supported on said driving-ring. Said bracket-arms 18 are provided on their sides toward said driving-ring with a vertical rib 30 for entering a cor-

responding notch or recess in the step 28 for the purpose of causing the outer grinding-bur to rotate with the driving-ring 17 and at the same time permit vertical adjustment of said outer grinding-bur. The said driving-ring is provided with the three radial integral projecting trunnions 21, to which the sweep 27 attaches by means of said trunnions entering corresponding recesses in said sweep in the ordinary manner, as shown in Figs. 1 and 3.

14 is a force-feed device consisting of a hub and a pair of opposite radially-arranged inclined blades, as shown in Figs. 1 and 8. Said hub of said force-feed is bored out to fit down over the upper end of the spindle 6, as shown in Fig. 1, and is prevented from rotating thereon by means of inwardly-projecting ribs fitting corresponding grooves in the sides of said spindle. Said force-feed device rests on the upper end of the outer grinding-bur 11 32 through the medium of the balls 12, forming a ball-bearing between them.

15 is a hand-screw passing down through the hub of the force-feed 14 into the hollow upper end of the spindle 6 into a nut 13, resting in a recess in said spindle in such manner that it will not turn or have vertical movement. By turning said hand-screw the outer grinding-bur 11 may be vertically adjusted or set with reference to the inner bur, so as to grind the material as coarse or fine as may be desired. The hand-screw serves to move the bur 11 32 downward, while the coil-springs 19, upon which it is seated, serve to move the said bur upward when the screw is turned upward, and the said springs prevent the upper bur from contact with the inner bur when there is no grain between them.

16 is a hopper secured to the upper end of the outer grinding-bur for receiving the grain to be ground, and 22 represents a series of keepers secured to the standards 4 by means of the bolt 25 and formed so as to project over the upper outer edge of the driving-ring 17 to prevent it from becoming disconnected from the pinions 24.

The machine may be held to its place when in operation by means of the guy-rods 26, having the inner end attached to the machine and the outer end staked to the earth in the ordinary manner.

In operation power is applied to the outer end of the sweep 27 in the ordinary manner. The grain to be ground is placed in the hopper 16. As the sweep goes around it turns with it the driving-ring 17 and also the outer grinding-bur 11 32, and as said driving-ring is connected with the master gear-wheel 5 through the medium of the stationary pinions said master gear-wheel and the inner grinding-bur 7 8 will be driven in the opposite direction, thus causing the machine to grind material very fast when the sweep is turned moderately slow, and also much better work is done than would be the case if both burs turned at different speeds in the

same direction or in case one remained stationary.

Having thus described my invention, what I claim as new, and desire to secure by Letters Patent, is as follows:

1. In a grinding-mill, the combination of a spider having an integral central vertical spindle, and having the outer ends of its arms provided with vertical standards, pinions journaled to said standards, a master gear-wheel journaled on said spindle and in mesh with said pinions, ball-bearings arranged between said spider and master gear-wheel for supporting said gear-wheel, a conical grinding-bur journaled at its upper end on said spindle, and supported on and adapted to be rotated by said gear-wheel, a driving-ring having cog-teeth adapted to mesh with said pinions, a sweep attached to said driving-ring, an outer conical grinding-bur inclosing said inner grinding-bur and journaled on said spindle immediately above said inner bur, and yieldingly supported on said driving-ring and adapted to be rotated therewith, and the means for vertically adjusting said outer grinding-bur with relation to said inner grinding-bur, all arranged to operate substantially as and for the purpose set forth.

2. In the grinding-mill shown and described the combination of the spider 3 secured to a suitable feed-box, and having the central vertical spindle 6, the master gear-wheel 5 journaled on said spindle, the inner conical grinding-bur 7, 8 journaled on said spindle and detachably connected at its lower end to said master gear-wheel and adapted to be rotated thereby, the radially-arranged stationary pinions 24 adapted to be in mesh with said master gear-wheel, the driving-ring 17 having cog-teeth arranged to be in mesh with said pinions opposite said master gear-wheel, the outer conical grinding-bur 11, 32 journaled at its upper end on said spindle immediately above the inner grinding-bur 7, 8, and yieldingly seated on said driving-ring and adapted to be rotated thereby in the opposite direction from said inner grinding-bur, and the means for vertically adjusting said outer grinding-bur with relation to said inner grinding-bur, all arranged to operate substantially as and for the purpose set forth.

3. In the grinding-mill shown and described the combination of the outer grinding-bur 11, 32, the driving-ring 17 having the inwardly-projecting step or lug 28, the coil-spring 19 seated on said step, and the bracket-arm 18 secured to said grinding-bur and seated on said spring, and having the vertical rib 30 for fitting a corresponding recess in said step, all arranged to operate substantially as and for the purpose set forth.

4. In a grinding-mill, the combination of a base, a vertical spindle 6, stationary force-feed arms secured to the upper end of said spindle, an upper outer grinding-bur rotatable on said spindle beneath said feed-arms, a

lower inner grinding-bur coacting with said upper bur, a master-gear rotatable about said spindle and supporting and imparting motion directly to said lower bur, stationary standards arranged circumferentially about said master-gear, journals projecting inwardly from said standards, pinions on said journals and in mesh with said master-gear, a driving-ring encircling the upper bur and provided with cogs meshing with the cogs of said pinions, and connections between said driving-ring and upper bur, whereby the one serves directly to impart motion in its own direction to the other, substantially as and for the purpose set forth.

5. In the grinding-mill shown and described the combination of the spider 3 having the

outer ends of the arms terminate in the vertical standards 4, said standards having the vertical recesses 31, the adjustable pinion-box 20 23, the keeper 22, the bolt 25 for securing said box and keeper to said standard, the pinion 24 journaled on said bolt within said box 23, the master gear-wheel 5, and driving-ring 17 both in mesh with said pinions and adapted to rotate in opposite directions by reason of their connection with said pinions and the grinding-burs carried by said oppositely-rotating members, all arranged to operate substantially as and for the purpose set forth.

GENERAL M. DITTO.

Witnesses:

THOS. H. HUTCHINS,  
LEONARD B. HUTCHINS.