



US006883793B2

(12) **United States Patent**
Fortin et al.

(10) **Patent No.:** **US 6,883,793 B2**
(45) **Date of Patent:** **Apr. 26, 2005**

(54) **PORTABLE WORKBENCH HAVING COLLAPSIBLE SUPPORT STRUCTURE**

(75) Inventors: **Marc A. Fortin**, Brockville (CA); **John Bryan Mason**, Brockville (CA); **Mike G. Sirois**, Ottawa (CA); **Robert D. Waters**, Ottawa (CA); **Clifford D. Read**, Carp (CA)

(73) Assignee: **Black & Decker Inc.**, Newark, DE (US)

(*) Notice: Subject to any disclaimer, the term of this patent is extended or adjusted under 35 U.S.C. 154(b) by 80 days.

(21) Appl. No.: **10/245,092**

(22) Filed: **Sep. 17, 2002**

(65) **Prior Publication Data**

US 2004/0051223 A1 Mar. 18, 2004

(51) **Int. Cl.**⁷ **B25B 1/10**

(52) **U.S. Cl.** **269/139; 269/17**

(58) **Field of Search** 269/139, 329, 269/221, 222, 223, 224, 246, 244, 250–253, 285, 901, 17

(56) **References Cited**

U.S. PATENT DOCUMENTS

- 2,449,492 A 9/1948 Long
- 3,349,728 A 10/1967 Barecki et al.
- D210,360 S 3/1968 Gerakos
- 3,615,087 A 10/1971 Hickman
- 3,676,279 A 7/1972 Beaver
- D225,291 S 12/1972 Kastner
- D230,801 S 3/1974 Hickman et al.
- 3,841,619 A 10/1974 Hickman
- 4,034,684 A 7/1977 Carson et al.
- 4,061,305 A 12/1977 Beekenkamp
- 4,061,323 A 12/1977 Beekenkamp
- 4,073,484 A 2/1978 Beekenkamp
- 4,076,229 A 2/1978 Hickman

- D250,079 S 10/1978 Hickman et al.
- 4,127,260 A 11/1978 Hickman
- 4,140,309 A 2/1979 Hickman
- 4,154,435 A 5/1979 Alessio
- 4,155,386 A 5/1979 Alessio
- 4,157,174 A 6/1979 Hickman et al.
- 4,159,821 A 7/1979 Hickman
- D253,212 S 10/1979 Maruscak et al.
- 4,169,606 A 10/1979 Hickman
- D256,533 S 8/1980 Alessio
- 4,216,949 A 8/1980 Hickman
- D256,641 S 9/1980 Wilson et al.
- 4,223,881 A 9/1980 Hickman
- 4,236,599 A 12/1980 Luff et al.
- 4,248,411 A 2/1981 Wagster et al.
- 4,252,304 A 2/1981 Pettican
- 4,256,294 A 3/1981 Hickman et al.
- 4,276,955 A 7/1981 Hickman

(Continued)

FOREIGN PATENT DOCUMENTS

- AU 532153 B 9/1983
- DE 19909830 A1 9/2000
- FR 2442700 A 6/1980
- GB 1 422 521 1/1976
- GB 2 267 674 A 12/1993
- WO WO 00/53375 9/2000

Primary Examiner—Robert C. Watson

(74) *Attorney, Agent, or Firm*—Harness, Dickey & Pierce, P.L.C.

(57) **ABSTRACT**

A portable workbench includes a top structure, a support structure and a collapsible frame. The top structure includes upper work supporting surfaces lying in a common plane and longitudinally extending opposed side portions defining clamping surfaces. A linkage mechanism cooperates with the frame to actuate the workbench between an expanded working position and a collapsed transport position. A lever releasably cooperates with the frame to maintain the workbench in a locked expanded position.

27 Claims, 9 Drawing Sheets

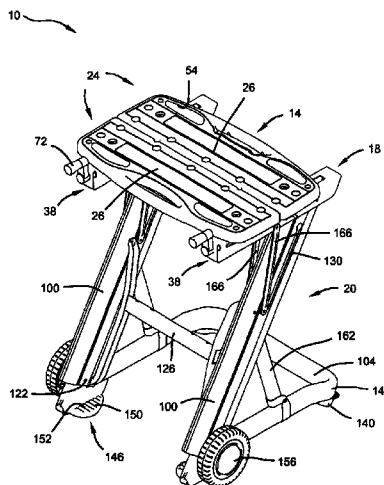

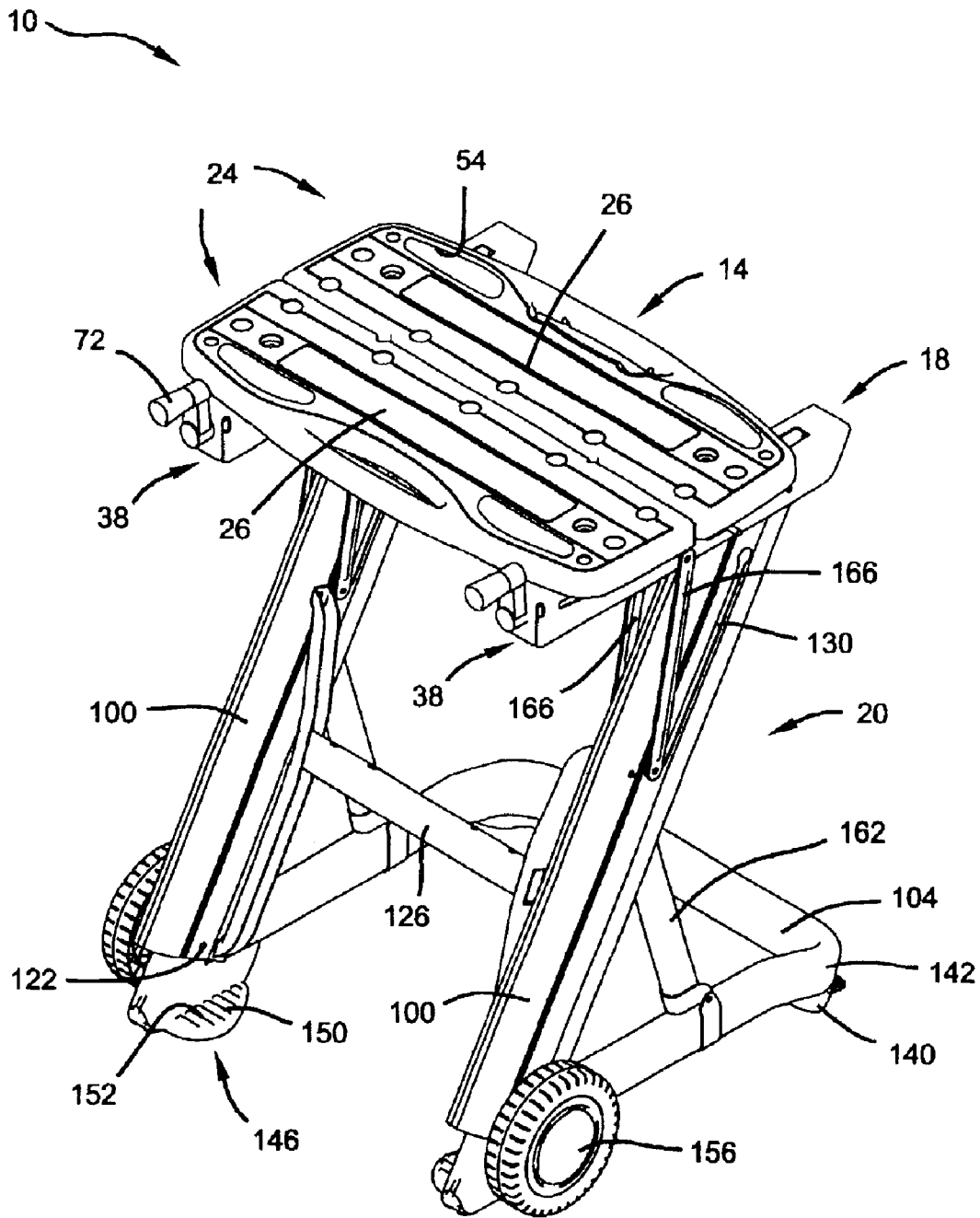

Figure 1

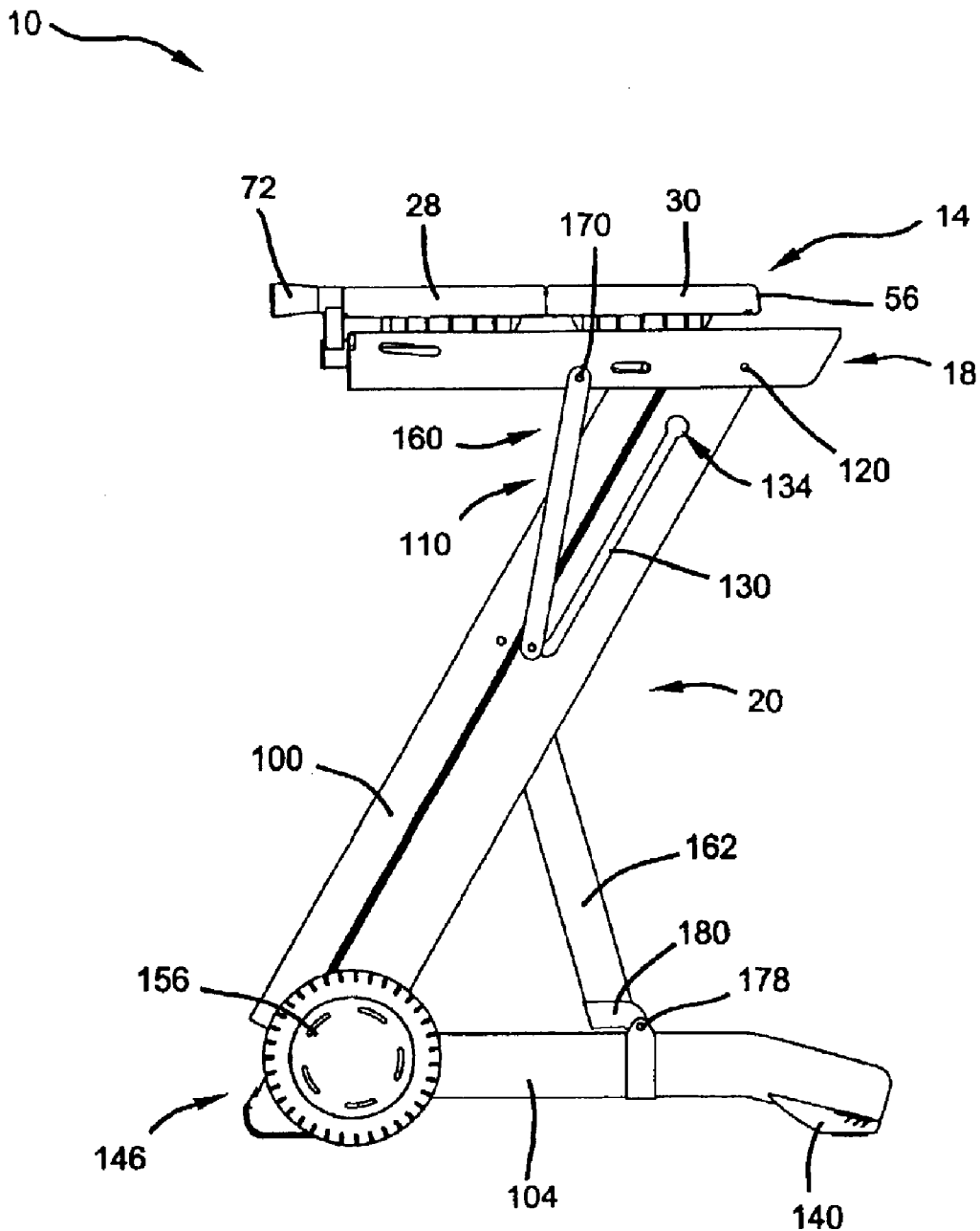

Figure 2

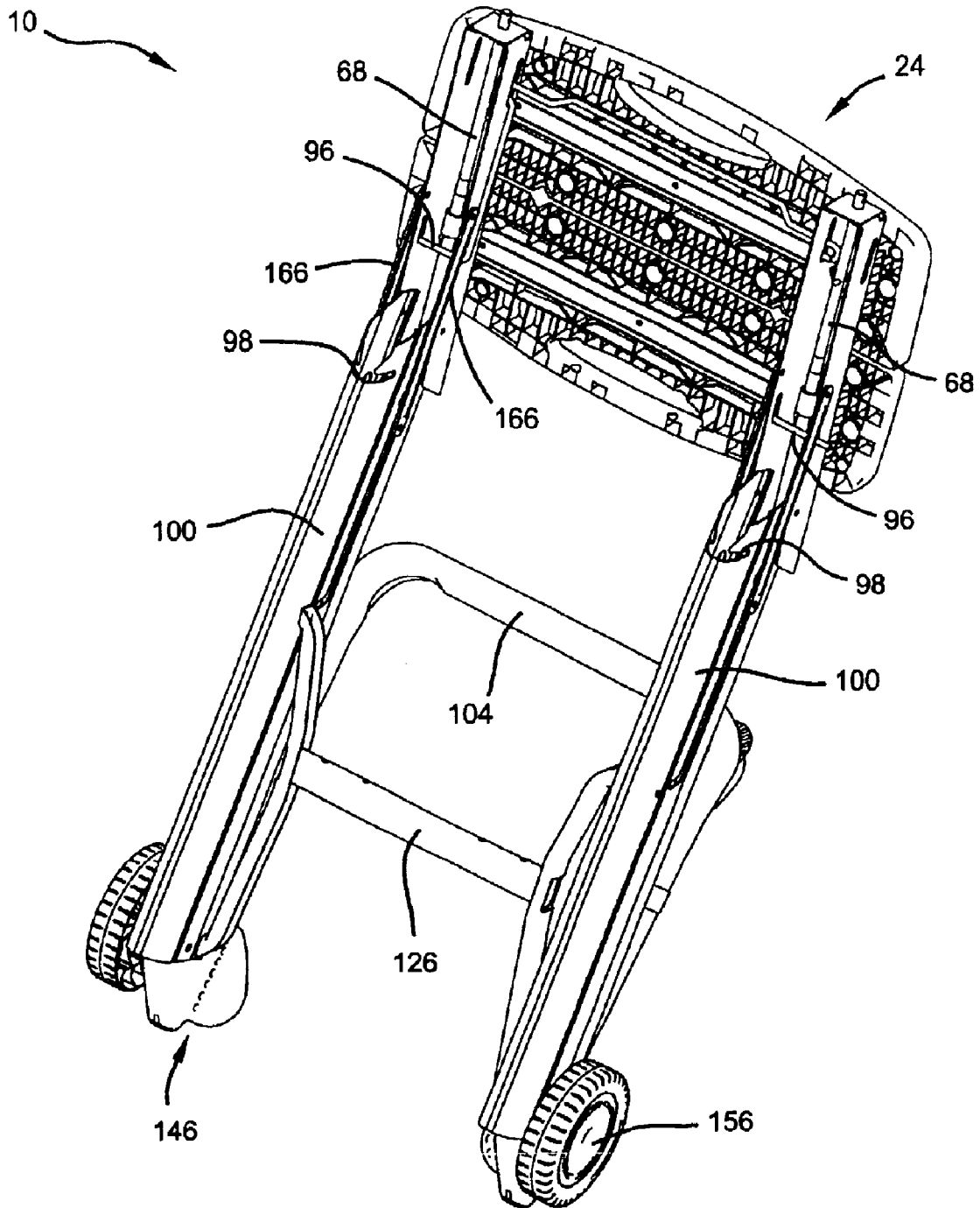

Figure 3

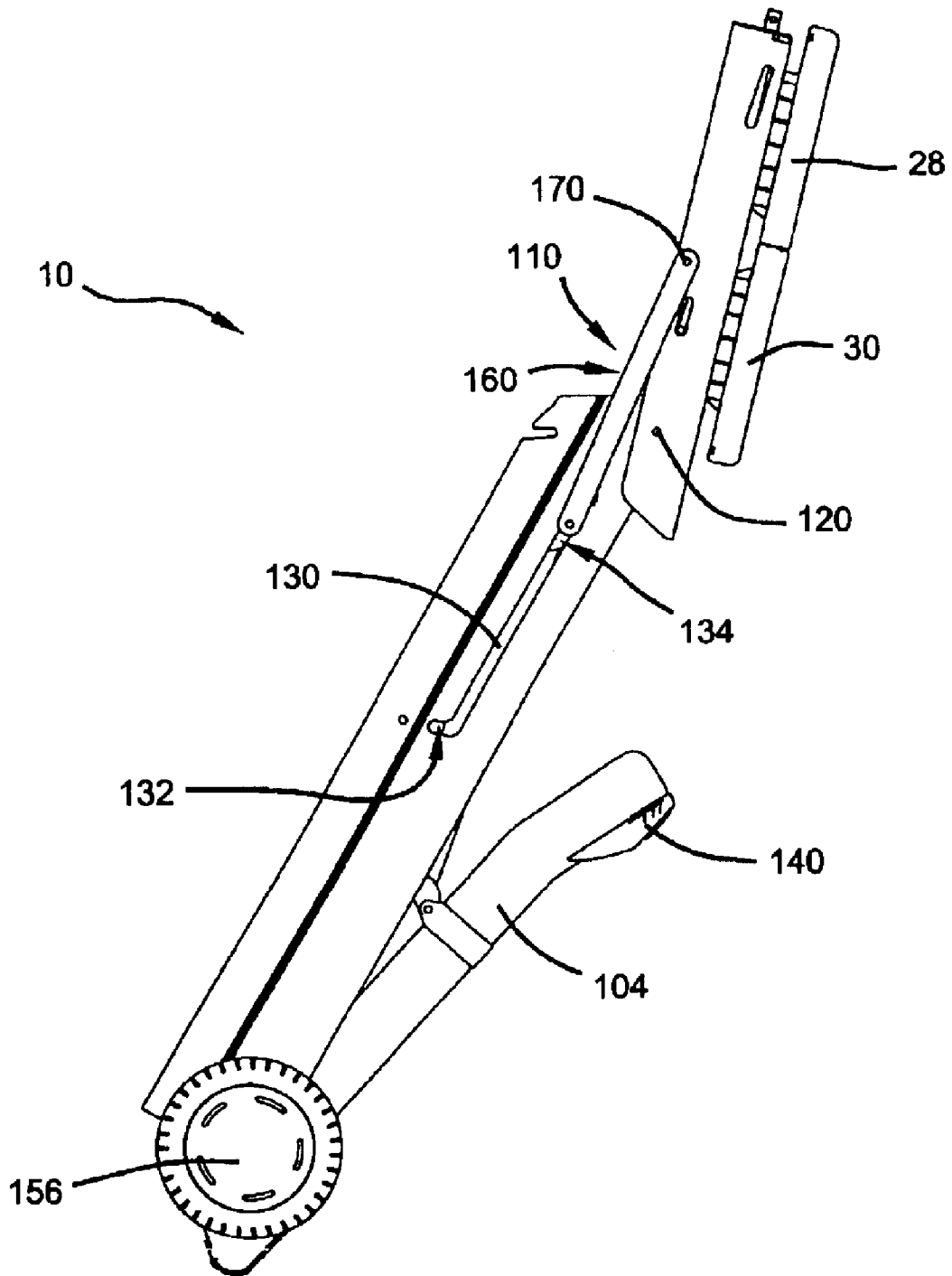

Figure 4

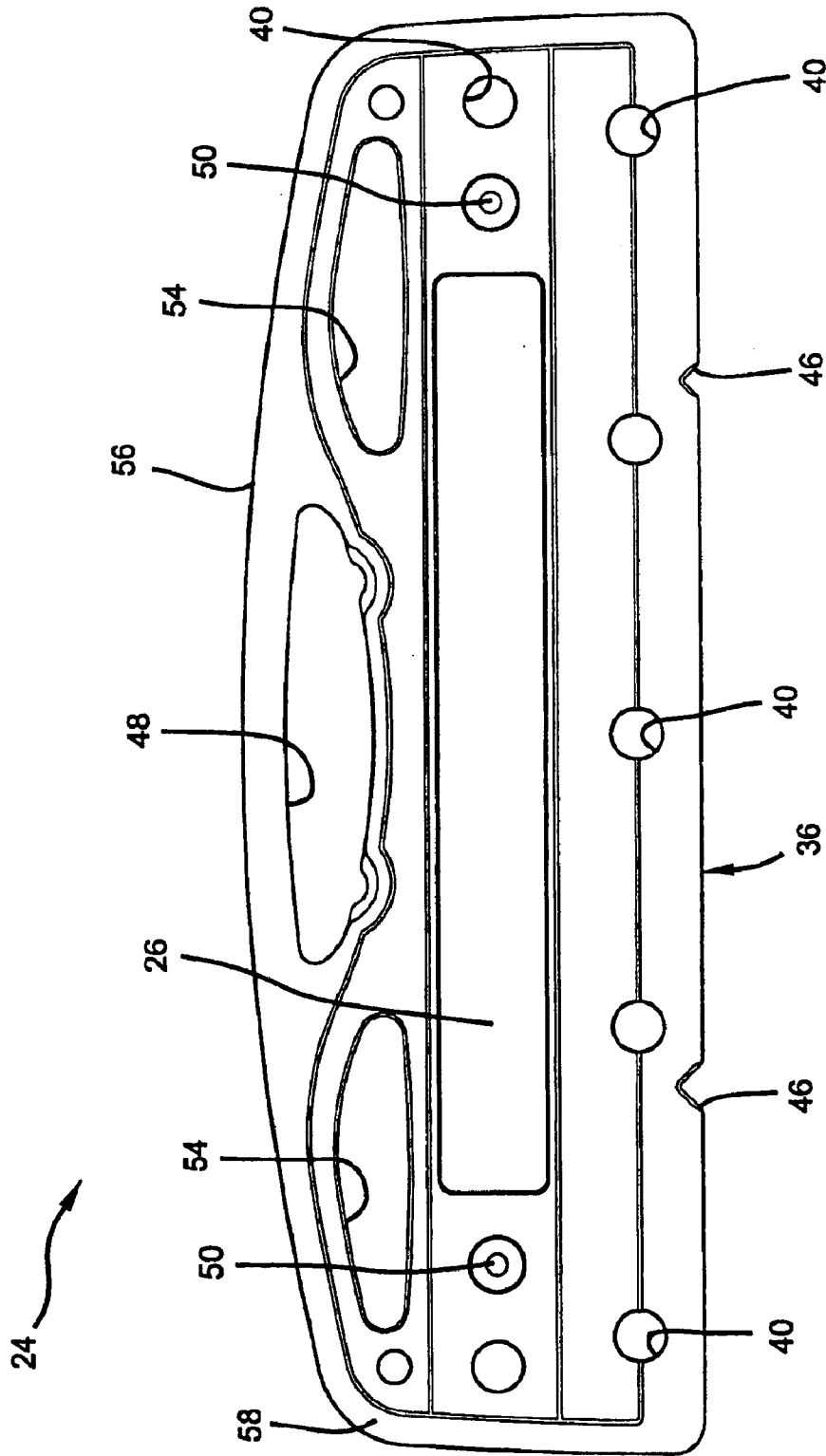

Figure 5

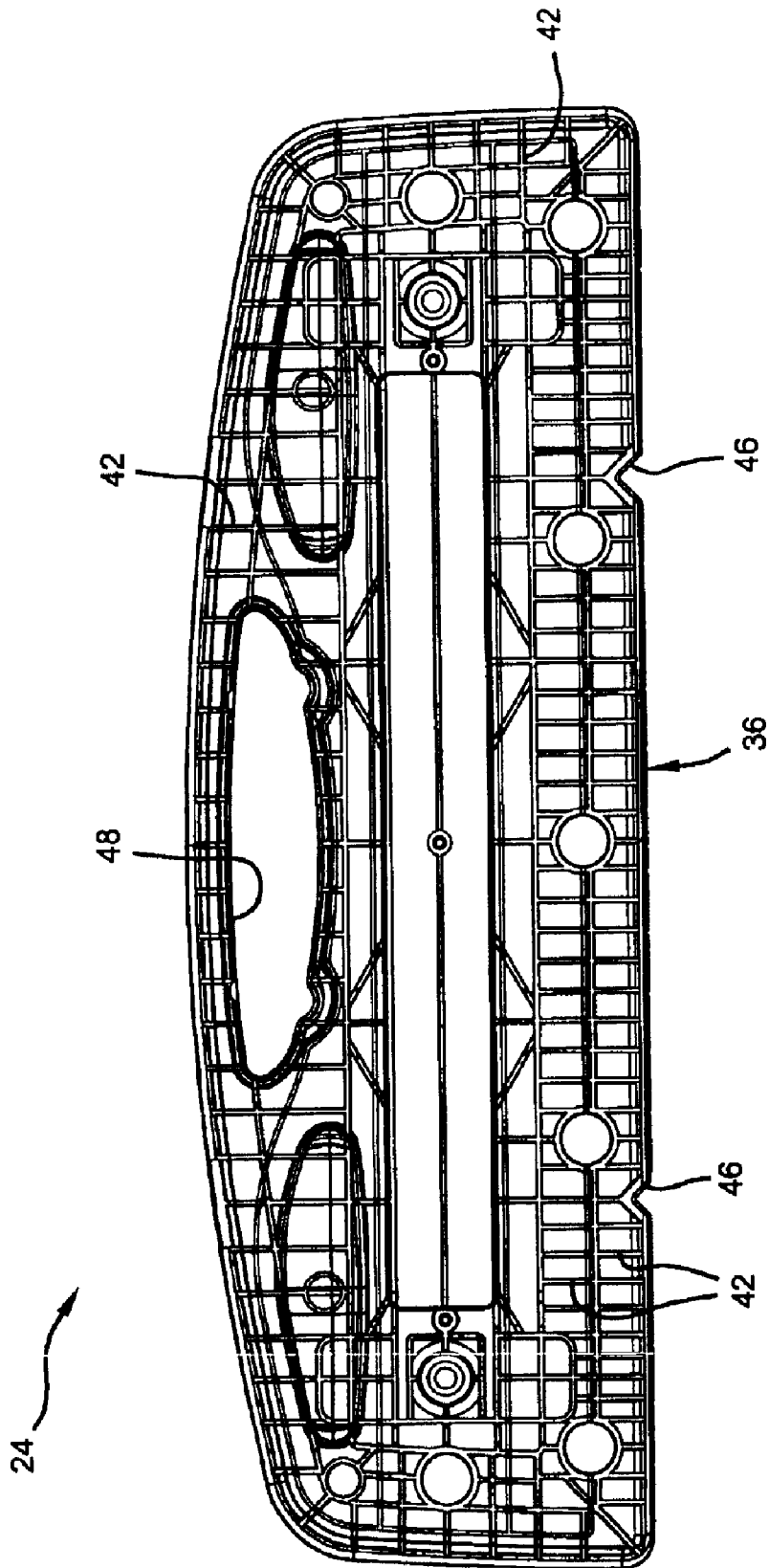

Figure 6

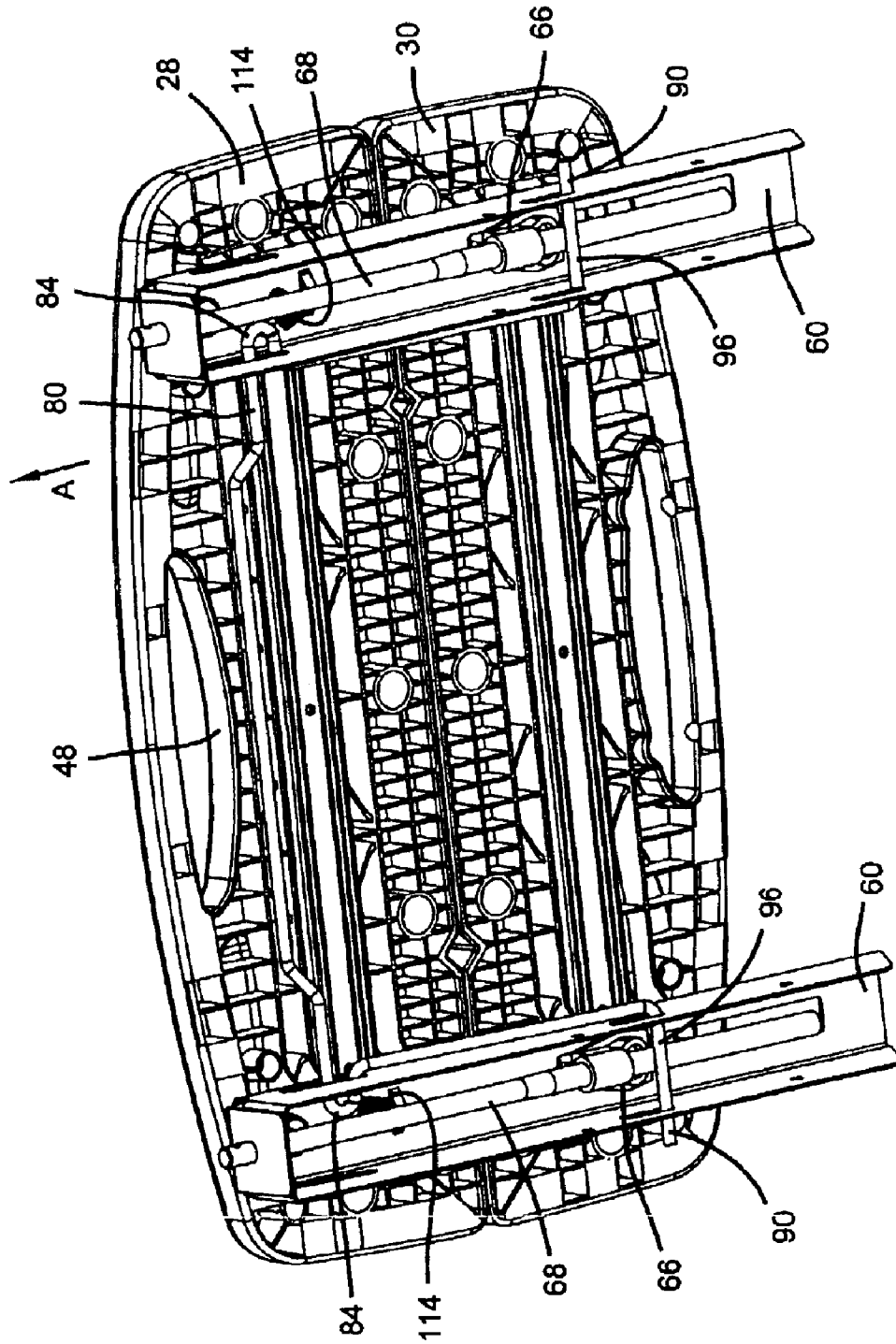

Figure 7

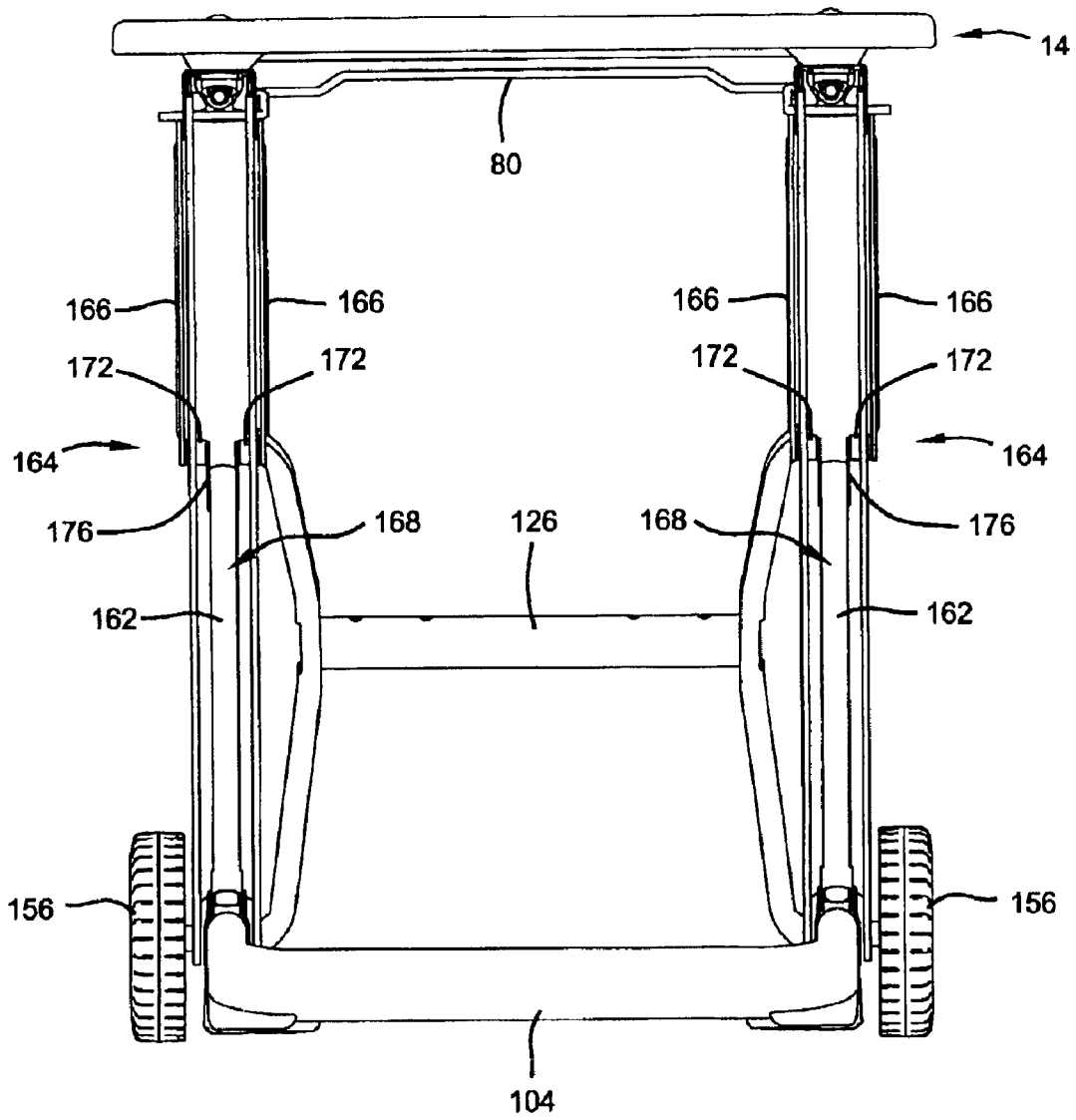

Figure 8

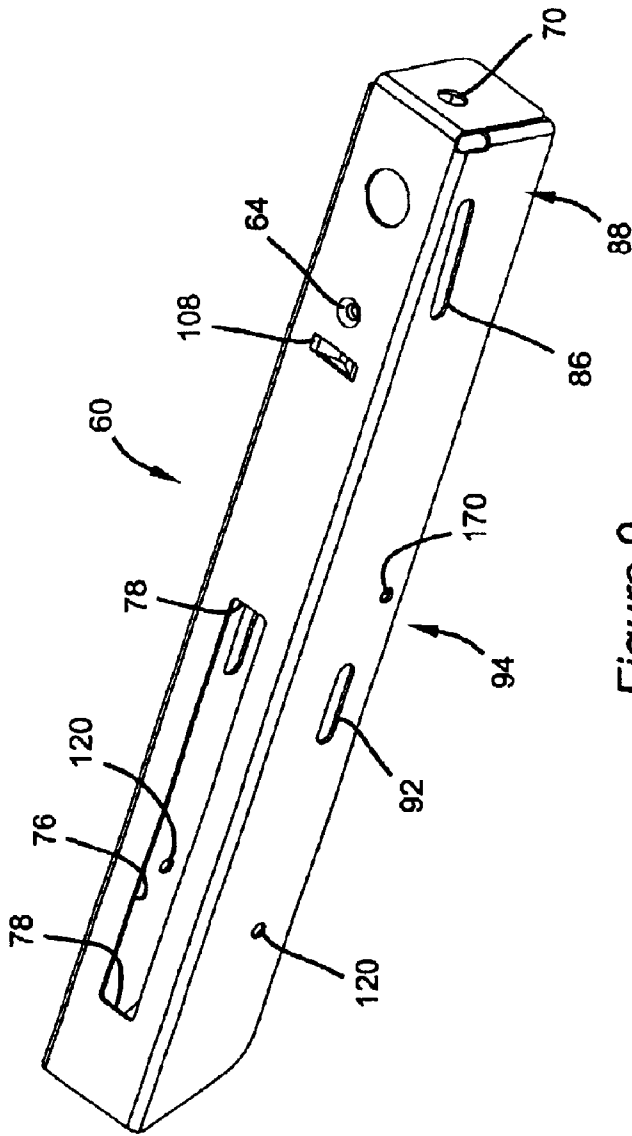

Figure 9

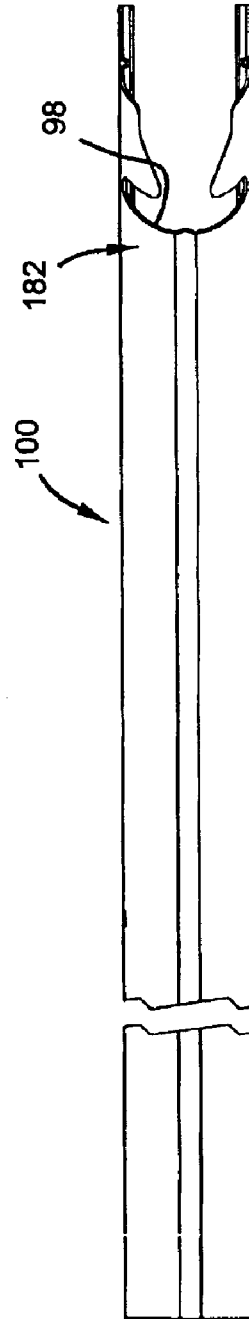

Figure 10

1

PORTABLE WORKBENCH HAVING COLLAPSIBLE SUPPORT STRUCTURE

FIELD OF THE INVENTION

The present invention relates to a workbench and more specifically to a collapsible portable workbench.

BACKGROUND OF THE INVENTION

Workbenches incorporating a workpiece clamping device provide a convenient structure to secure a workpiece while performing a tooling operation. This type of clamping workbench generally includes a pair of top members, one of which is fixed to a supporting structure, while the other is adjustable along the supporting structure toward and away from the first one of the top members by a screw-type handle translation device.

Certain workbenches of this type include removable base assemblies for transportation and storage purposes while others incorporate an integrated collapsible supporting structure. Often, workbenches having a collapsible feature are cumbersome and otherwise awkward to manipulate.

While the above described arrangement has proven to be successful, a need has arisen for a more simple portable workbench which is light in weight and easy to manipulate between an expanded working position and a collapsed storage position.

SUMMARY OF THE INVENTION

A portable workbench collapsible from an expanded working position to a collapsed transport position is provided. The workbench includes a top structure having a pair of elongated mutually adjacent top members disposed generally transversely thereto. Each top member has upper work supporting surfaces lying generally in a common plane. The pair of top members include longitudinally extending opposed side portions defining clamping surfaces.

A support structure supports the top structure and includes a pair of laterally disposed support members for mounting the top members thereon. The support structure further includes a clamping device for selectively transversing at least one of the top members toward the other of the top members to provide for clamping of a workpiece therebetween.

A collapsible frame includes a pair of legs and a linkage mechanism. Each of the legs are pivotally coupled at one end to one of the support members and pivotally coupled at an opposite end to a support base. The linkage mechanism is coupled between the support members and the support base such that the frame is movable between an expanded position and a collapsed position. The top surface and the support base form a parallel, spaced apart relationship with the pair of legs extending therebetween in the expanded position. The top structure, the support structure and the support base form a substantially coplanar relationship in the collapsed position.

Further areas of applicability of the present invention will become apparent from the detailed description provided hereinafter. It should be understood that the detailed description and specific examples, while indicating the preferred embodiment of the invention, are intended for purposes of illustration only and are not intended to limit the scope of the invention.

2

BRIEF DESCRIPTION OF THE DRAWINGS

The present invention will become more fully understood from the detailed description and the accompanying drawings, wherein:

FIG. 1 is a front perspective view of the workbench according to the present invention shown in an expanded position;

FIG. 2 is a side view of the workbench shown in an expanded position;

FIG. 3 is a rear perspective view of the workbench shown in a collapsed position;

FIG. 4 is a side view of the workbench shown in a collapsed position;

FIG. 5 is a top view of a top member of the workbench;

FIG. 6 is a bottom view of a top member of the workbench;

FIG. 7 is a bottom perspective view of the top structure and support structure of the workbench;

FIG. 8 is a rear view of the workbench in an expanded position;

FIG. 9 is a perspective view of a support member; and

FIG. 10 is a plan view of a leg incorporated in the collapsible frame.

DETAILED DESCRIPTION OF THE PREFERRED EMBODIMENTS

The following description of the preferred embodiment(s) is merely exemplary in nature and is in no way intended to limit the invention, its application, or uses.

With initial reference to FIGS. 1-4, a portable workbench 10 according to the present invention is shown. Workbench 10 generally includes a top structure 14, a support structure 18 and a collapsible frame 20. Workbench 10 is movable between an expanded position, as shown in FIG. 1, and a collapsed position, as shown in FIG. 3.

With continued reference to FIGS. 1-4 and further reference to FIGS. 5 and 6, top structure 14 will be described in greater detail. Top structure 14 includes a pair of elongated mutually adjacent top members 24 including upper work supporting surfaces 26 lying generally in a common plane. Top members 24 are further defined by stationary member 28 and translating member 30. Top members 24 include longitudinally extending opposed side portions 36 defining clamping surfaces. As will be described in greater detail, translating member 30 is adjustable toward and away from stationary member 28 by way of a screw-type clamping device 38.

Top members 24 are preferably made of injection molded polypropylene. Each top member 24 includes molded thereon a plurality of bore sections 40 for durability. Bore sections 40 also accept accessory pegs (not shown) which increase the clamping range for larger workpieces. The underside of each top member 24 (FIG. 6) includes a plurality of rib sections 42 formed thereon for increased stability. Rib sections 42 are shown generally as rectangular portions but may also be arranged in other geometric shapes such as hexagonal for example. Opposing clamping detents 46 are formed along each opposed side portion 36. Clamping detents 46 provide a gripping function to locate a workpiece in a fixed location between the clamping surface 36 or alternatively are arranged to accommodate extending portions of a workpiece. A handle 48 is integrally formed on an outer edge of each top member 24. A pair of counter bores 50 are arranged on each top member 24 for accepting fasteners to couple support structure 18 thereto.

Recessed portions **54** arranged on the outer corners of each top member **26** provide convenient locating areas for small parts such as fasteners and the like. The transition between working surfaces **26** and a peripheral edge **56** of top members **26** is defined by a radial contour **58**. Radial contour **58** provides increased stability to the top structure **14** as a whole and is also accommodating to the touch.

Turning now to FIGS. 7 and 9, support structure **18** will be described in greater detail. Support structure **18** includes a pair of generally u-shaped laterally disposed support members **60**. Stationary member **28** is coupled through blind bores **50** to support members **60** at mounting bores **64** with conventional fasteners (not shown). Translating member **30** is coupled through respective blind bores **50** to mounting collars **66**. Mounting collars **66** are threadably journaled around respective adjusting rods **68**. Collars **66** are guided along threads formed along adjusting rods **68** upon rotation of the adjusting rods **68**. Adjusting rods **68** extend through a front passage **70** incorporated on each support member **60** and terminate at handles **72**. Adjusting rods **68** cooperate with collars **66** to translate rotational movement of handles **72** into lateral movement of translating member **30** along support members **60**. In this way, cutout portion **76** accommodates the linear movement of collar **66** therealong. Outer edges **78** of cutout portion **76** bound collars **66** and define the maximum travel of translating member **30**. It will be appreciated that other mechanical arrangements may be employed to translate top members **24** relative to each other in a clamping arrangement.

A handle or lever **80** is slidably coupled between support members **60** for releasing the collapsible frame **20** from an expanded position to a collapsed position. Looped portions **84** are guided along opposing slots **86** arranged along a front portion **88** of support members **60**. Similarly, the terminal ends **90** of lever **80** extend through and are guided along slots **92** incorporated on a central portion **94** of support members **60**. As will be described in greater detail with respect to FIG. 10, latch portion **96** of lever **80** is urged toward engagement with notches **98** formed on legs **100** by biasing members **114**. The cooperation of latch portions **96** with notches **98** maintains workbench **10** in a stable expanded position. Biasing members **114** are coupled on a first end to loop portion **84** of handle **80** and a mounting extension **108** of support members **60** on a second end. Support members **60** are preferably made of a rigid material such as roll formed metal.

With reference now to all Figures, collapsible frame **20** incorporating linkage mechanism **110** will be described. Frame **20** includes a pair of legs **100** pivotally extending between respective support members **18** and a support base **104**. Legs **100** are connected on upper ends to respective support members **18** at support member pivot points **120**. Similarly legs **100** are connected on lower ends to respective base support pivot points **122**. In an expanded working position (FIGS. 1 and 2), legs **100** separate top structure **14** and support base **104** into a parallel, spaced apart relationship. Legs **100** are laterally supported by cross brace **126**. Cross brace **126** is shown having a generally u-shaped geometry however alternative arrangements may be employed. A slot **130** is incorporated on each leg **100** to guide linkage mechanism **110** between expanded and collapsed positions. Slots **130** are preferably arranged in a J-shaped orientation whereby linkage mechanism **110** cooperates with a curved lower section **132** of slots **130** in an expanded position and cooperates with a generally linear upper section **134** of slots **130** in a collapsed position.

Support base **104** includes ground engaging support pads **140** secured on outer corners **142**. Ground engaging feet **146**

extend at the leg, base intersection. Feet **146** each include an inwardly extending flange **150** providing added ground gripping capability. Each flange **150** includes gripping ridges **152** formed along an upper edge. In this way, a user may step on one or both flange **150** to provide increased workbench stability. Wheels **156** are rotatably coupled to legs **100** at the leg, base intersection. Wheels **156** are arranged such that they are laterally displaced away from the ground when workbench **10** is in an expanded position. When workbench **10** is in a collapsed position and tilted toward wheels **156** at an angle with the ground, wheels **156** engage the ground to facilitate movement therealong. When workbench **10** is in a collapsed position and tilted away from wheels **156**, the wheels **156** are precluded from ground engagement. In this way, workbench **10** may be tilted against a wall in a stable position with feet engaging the ground (FIG. 4).

Linkage mechanism **110** includes a pair of link members **160** operatively connecting support members **60** and legs **100**. In addition, linkage mechanism **110** includes a pair of connecting members **162** operatively connecting support base **104** and legs **100**. Each link member **160** generally includes an inboard and outboard slide arm **166**. Slide arms **166** are coupled on a first end for pivotal movement to respective support members **60** at inboard and outboard pivot points **170**. Slide arms **166** are coupled on a second end to respective inboard and outboard posts **172**. Posts **172** extend through and are translatable along slots **130** formed along legs **100**. Posts **172** are hingedly interconnected to first ends **164** of respective connecting members **162** by way of links **176**. Second ends **168** of connecting members **162** are pivotally secured to link pivot joints **178** incorporated at mounting flanges **180** extending from support base **104**.

The operation of linkage mechanism **110** will now be described in the context of moving the workbench **10** from an expanded position (FIG. 1) to a collapsed position (FIG. 3). First, a user grasps lever **80** extending under stationary member **28** and actuates lever **80** in a direction toward the user defining a release direction (arrow A, FIG. 7). In a first method of operation, the user may place a first hand on a portion of the peripheral edge of stationary top member **28** while actuating lever **80** with the other hand. In a second method of operation, the efficiency of linkage mechanism **110** allows a user to manipulate workbench **10** from an expanded position to a collapsed position with one hand. Accordingly, a user would position a thumb around peripheral edge **56** of stationary member **28** and pull lever **80** in the release direction with the remaining fingers of the same hand.

Movement of lever **80** in the release direction disengages latch portions **96** of lever **80** from notches **98** on legs **100**. The user subsequently rotates work surface **26** upward causing support members **60** to rotate about legs **100** at support member pivot points **120** (clockwise as viewed from FIG. 2). Rotational movement of support members **60** about pivot points **120** urges link members **166** upward along slots **130**. Translation of link members **166** along slots **130** concurrently pulls the first ends **164** of connecting members **162** along the same path by way of the post and link arrangement. Translation of first ends **164** of connecting members **162** causes the second ends **168** of connecting members **162** to pivot about link pivot joints **178**. Such movement urges support base **104** to rotate toward legs **100** about base pivot joints **122** (counter-clockwise as viewed from FIG. 2). Rotation of top structure **14** continues until posts **172** engage terminal upper end **134** of slots **130**.

To return the workbench **10** to an expanded position from a collapsed position a user rotates top structure **14** counter-

5

clockwise as viewed from FIG. 4. Concurrently, link members 166 follow slot 130 toward J-section 132. Top structure 14 and support base 104 expand to the generally parallel relationship upon rotation about respective support member and base pivot points 120, 122. Each latch 96 of lever 80 slides along an outer front surface 182 of leg 100 near notch 98 until engaging notch 98. Biasing members 114 subsequently urge each latch 96 into notch 98 thereby achieving a locked expanded position.

Those skilled in the art can now appreciate from the foregoing description that the broad teachings of the present invention can be implemented in a variety of forms. For example, the workbench disclosed herein is described having slidable link members cooperating on each leg of the collapsible frame. It is envisioned however that the workbench may alternatively incorporate a single linkage cooperating with one leg while reaching similar results. Therefore, while this invention has, been described in connection with particular examples thereof, the true scope of the invention should not be so limited since other modifications will become apparent to the skilled practitioner upon a study of the drawings, the specification and the following claims.

What is claimed is:

1. A portable workbench comprising:

a working surface having a pair of top members lying in a common plane, said pair of top members including opposing side portions defining clamping surfaces;

a support structure supporting said top members and including a clamping device for selectively transversing one of said pair of top members toward the other of said top members to provide for clamping of a workpiece therebetween;

a pair of legs extending between said support structure and a base member;

a lever interconnected to said support structure, said lever movable between a locked position and a release position, said lever positioned in a notch incorporated on said pair of legs in said locked position thereby precluding relative movement of said support structure with said pair of legs, said lever movable out of engagement with said notch to said release position allowing pivotal movement between said support structure and said pair of legs; and

a linkage mechanism operatively connecting said support structure, said legs and said base, said linkage mechanism including first and second link members pivotally coupled at first ends to said support structure and slidably coupled at opposite second ends to slots formed on said legs.

2. The workbench of claim 1 wherein said linkage mechanism moves the workbench between an expanded position and a collapsed position, said working surface and said base forming a laterally spaced apart relationship in said expanded position, said working surface and said base forming a substantially coplanar relationship in said collapsed position.

3. The workbench of claim 2 wherein said slots include a substantially linear portion extending toward said base to a curved portion formed on a terminal end, said first and second link members engaged with said curved portion in said expanded position.

4. The portable workbench of claim 2 wherein said link members are further coupled at said second ends to first ends of first and second connecting members, said connecting members coupled to said base at opposite ends whereby

6

translation of said first and second link members along said slot pivots said working surface and said base about said legs between said expanded position and said collapsed position.

5. The portable workbench of claim 1, further comprising a pair of feet disposed thereon for contacting ground in said expanded position.

6. The portable workbench of claim 1 wherein said pair of feet extend in an inboard direction with respect to said legs, said feet having grooves disposed on upper surfaces thereof.

7. The portable workbench of claim 5, further comprising a pair of wheels disposed thereon, said wheels positioned on the workbench a distance from said feet whereby said wheels are laterally offset from said ground in said expanded position.

8. The portable workbench of claim 7 wherein said pair of wheels engage said ground in a rolling relationship upon tilting said workbench in a first direction and are precluded from contacting the ground upon tilting said workbench in a second direction while in said collapsed position.

9. The portable workbench of claim 1, further comprising a u-shaped support base coupled between said pair of legs.

10. A portable workbench comprising:

a top structure including a pair of elongated mutually adjacent top members disposed generally transversely thereto and each having upper work supporting surfaces lying generally in a common plane, said pair of top members including longitudinally extending opposed side portions defining clamping surfaces;

a support structure supporting said top structure, said support structure including a pair of laterally disposed support members for mounting said top members thereon, said support structure further including a clamping device for selectively transversing at least one of said top members toward the other of said top members to provide for clamping of a workpiece therebetween;

a collapsible frame having a pair of legs and a linkage mechanism, where each of said legs are pivotally coupled at one end to one of said support members and pivotally coupled at an opposite second end to a support base, said linkage mechanism operably coupled between said support members and said support base such that said frame is movable between an expanded position and a collapsed position, said top surface and said support base forming a parallel, spaced apart relationship with said pair of legs extending therebetween in said expanded position, said top structure, said support structure and said support base forming a substantially coplanar relationship in said collapsed position; and

a pair of feet and a pair of wheels disposed on said frame, said pair of feet contacting ground in said expanded position, said wheels positioned on said frame a distance from said feet whereby said wheels are laterally offset from said ground in said expanded position.

11. The portable workbench of claim 10 wherein said pair of feet extend in an inboard direction with respect to said legs, said feet having grooves disposed on upper surfaces thereof.

12. The portable workbench of claim 10 wherein said pair of wheels engage said ground in a rolling relationship upon tilting said workbench in a first direction and are precluded from contacting the ground upon tilting said workbench in a second direction while in said collapsed position.

13. The portable workbench of claim 10, further comprising a first and second link member pivotally connected to a respective one of said support members at a first end and slidably coupled to a respective one of said pair of legs at opposite ends.

14. The portable workbench of claim 13 wherein said pair of legs include slots formed thereon for accepting a respective post extending from a respective one of said link members, wherein each of said respective posts slidably translate along said slot upon movement of said collapsible frame between said expanded position and said collapsed position.

15. The portable workbench of claim 14, further comprising first and second connecting members pivotally interconnected to respective first and second link members on a first end and pivotally connected to said base at opposite second ends, said connecting members actuating said base between said expanded and said collapsed position upon movement of said link members along said slot.

16. The portable workbench of claim 10, further comprising a lever interconnected to said support structure, said lever movable between a locked position and a release position, said lever positioned in a notch incorporated on said pair of legs in said locked position thereby precluding relative movement of said support structure with said pair of legs, said lever movable out of engagement with said notch to said release position allowing pivotal movement between said support structure and said pair of legs.

17. The portable workbench of claim 10, further comprising a u-shaped support base coupled between said pair of legs.

18. A portable workbench comprising:

a working surface having a pair of top members lying in a common plane, said pair of top members including opposing side portions defining clamping surfaces;

a support structure supporting said top members and including a clamping device for selectively transversing one of said pair of top members toward the other of said top members to provide for clamping of a workpiece therebetween;

a collapsible frame including first and second legs pivotally connected to said support structure on first ends and pivotally connected to a base on opposite second ends, said frame movable between an expanded position and a collapsed position, said working surface and said base forming a parallel, spaced apart relationship with said pair of legs extending therebetween in said expanded position, said working surface and said base forming a substantially coplanar relationship in said collapsed position; and

a linkage mechanism operatively connecting said support structure, said legs and said base, said linkage mechanism including first and second link members pivotally coupled at first ends to said support structure and slidably coupled at opposite second ends to slots formed on said legs, said link members further coupled at said second ends to first ends of first and second connecting members, said connecting members coupled to said base at opposite ends whereby translation of said first and second link members along said slot pivots said working surface and said base about said legs between said expanded position and said collapsed position.

19. The workbench of claim 18 wherein said slots include a substantially linear portion extending toward said base to

a curved portion formed on a terminal end, said first and second link members engaged with said curved portion in said expanded position.

20. The portable workbench of claim 18, further comprising a pair of feet disposed thereon for contacting ground in said expanded position.

21. The portable workbench of claim 18 wherein said pair of feet extend in an inboard direction with respect to said legs, said feet having grooves disposed on upper surfaces thereof.

22. The portable workbench of claim 20, further comprising a pair of wheels disposed thereon, said wheels positioned on the workbench a distance from said feet whereby said wheels are laterally offset from said ground in said expanded position.

23. The portable workbench of claim 22 wherein said pair of wheels engage said ground in a rolling relationship upon tilting said workbench in a first direction and are precluded from contacting the ground upon tilting said workbench in a second direction while in said collapsed position.

24. The portable workbench of claim 18, further comprising a lever interconnected to said support structure, said lever movable between a locked position and a release position, said lever positioned in a groove incorporated on said support structure in said locked position thereby precluding relative movement of said support structure with said pair of legs, said lever movable out of engagement with said groove to said release position allowing pivotal movement between said support structure and said pair of legs.

25. The portable workbench of claim 18 whereby first and second link members each include a pair of link members extending from opposite sides of said support structure to opposite sides of said pair of legs.

26. The portable workbench of claim 18, further comprising a u-shaped support base coupled between said pair of legs.

27. A portable workbench comprising:

a working surface having a pair of top members lying in a common plane, said pair of top members including opposing side portions defining clamping surfaces;

a support structure supporting said top members;

a pair of legs extending between said support structure and a base member;

a linkage mechanism operatively connecting said support structure, said legs and said base, said linkage mechanism including first and second link members pivotally coupled at first ends to said support structure and slidably coupled at opposite second ends to slots formed on said legs; and

a lever interconnected to said support structure proximate said top members and movable in a lateral direction relative said top members between a locked position and a release position, said lever precluding relative movement of said support structure with said pair of legs in said locked position and allowing pivotal movement between said support structure and said pair of legs in said release position.