

(12) STANDARD PATENT
(19) AUSTRALIAN PATENT OFFICE

(11) Application No. **AU 2017443955 B2**

(54) Title
Absorbent article with reduced sagging and method for manufacturing the absorbent article

(51) International Patent Classification(s)
A61F 13/532 (2006.01) **A61F 13/535** (2006.01)
A61F 13/49 (2006.01) **A61F 13/539** (2006.01)

(21) Application No: **2017443955** (22) Date of Filing: **2017.12.21**

(87) WIPO No: **WO19/125231**

(43) Publication Date: **2019.06.27**

(44) Accepted Journal Date: **2020.11.19**

(71) Applicant(s)
Essity Hygiene and Health Aktiebolag

(72) Inventor(s)
SILLERSTRÖM, Filip; CORNELIUSSON, Helena; GUIDOTTI, Edward

(74) Agent / Attorney
Griffith Hack, Level 10 161 Collins St, MELBOURNE, VIC, 3000, AU

(56) Related Art
EP 3238676 A1
EP 2740452 A1
EP 3058918 A1
US 2012/0316528 A1
US 2017/0079853 A1
WO 2011/106663 A1
WO 2007/046974 A1



(51) International Patent Classification:

A61F 13/532 (2006.01) A61F 13/535 (2006.01)
A61F 13/49 (2006.01) A61F 13/539 (2006.01)

(21) International Application Number:

PCT/SE2017/000054

(22) International Filing Date:

21 December 2017 (21.12.2017)

(25) Filing Language:

English

(26) Publication Language:

English

(71) Applicant: **ESSITY HYGIENE AND HEALTH AKTIEBOLAG** [SE/SE]; 405 03 Göteborg (SE).

(72) Inventors: **SILLERSTRÖM, Filip**; c/o Essity Hygiene and Health AB, SE-405 03 Göteborg (SE). **CORNELIUSSON, Helena**; c/o Essity Hygiene and Health AB,

SE-405 03 Göteborg (SE). **GUIDOTTI, Edward**; c/o Essity Hygiene and Health AB, SE-405 03 Göteborg (SE).

(74) Agent: **ESSITY HYGIENE AND HEALTH AKTIEBOLAG**; Essity IP Department, 405 03 Göteborg (SE).

(81) Designated States (unless otherwise indicated, for every kind of national protection available): AE, AG, AL, AM, AO, AT, AU, AZ, BA, BB, BG, BH, BN, BR, BW, BY, BZ, CA, CH, CL, CN, CO, CR, CU, CZ, DE, DJ, DK, DM, DO, DZ, EC, EE, EG, ES, FI, GB, GD, GE, GH, GM, GT, HN, HR, HU, ID, IL, IN, IR, IS, JO, JP, KE, KG, KH, KN, KP, KR, KW, KZ, LA, LC, LK, LR, LS, LU, LY, MA, MD, ME, MG, MK, MN, MW, MX, MY, MZ, NA, NG, NI, NO, NZ, OM, PA, PE, PG, PH, PL, PT, QA, RO, RS, RU, RW, SA, SC, SD, SE, SG, SK, SL, SM, ST, SV, SY, TH, TJ, TM, TN, TR, TT, TZ, UA, UG, US, UZ, VC, VN, ZA, ZM, ZW.

(84) Designated States (unless otherwise indicated, for every kind of regional protection available): ARIPO (BW, GH,

(54) Title: ABSORBENT ARTICLE WITH REDUCED SAGGING AND METHOD FOR MANUFACTURING THE ABSORBENT ARTICLE

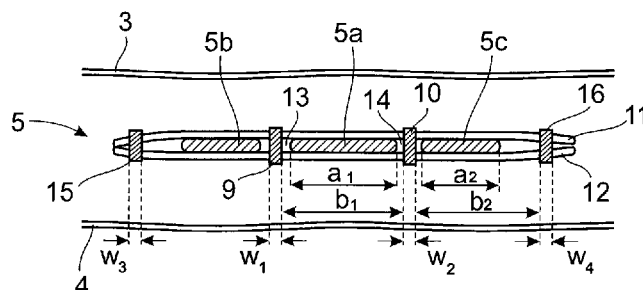

Fig.2

(57) Abstract: The present invention relates to an absorbent article (1) comprising an absorbent core (5) sandwiched between a liquid-permeable topsheet (3) and a liquid-impermeable backsheet (4), said article (1) being arranged along a longitudinal axis (y1) and a transversal axis (x1) extending in a perpendicular direction in relation to the longitudinal axis (y1) and said article (1) defining a front portion (6), a back portion (7) and a crotch portion (8), wherein said absorbent core (5) comprises an absorbent component (5a, 5b, 5c) enclosed by a core cover comprising an upper side and a lower side, and a sealing arrangement for joining said upper and lower core cover sides (11, 12) and comprising two channel sealings (9, 10), in the crotch portion (8), defining a first channel sealing width (w1) and a second channel sealing width (w2), and also comprising two side seams (15, 16) along the sides of said core (5), wherein a centre segment (5a) having a first width (a1) is defined in the absorbent component (5a, 5b, 5c) between the channel sealings (9, 10) and two side segments (5b, 5c) each having a second width (a2) are defined in the absorbent component (5a, 5b, 5c) outside each channel sealing (9, 10). Furthermore, the absorbent component (5a, 5b, 5c) is formed so that the total amount of absorbent material in the centre segment (5a) is generally equal to, or greater than, the total amount of absorbent material in each one of the side segments (5b, 5c), that a third width (b1) is defined between the channel sealings (9, 10) and a fourth width (b2) is defined between a channel sealing (9, 10) and a side seam (15, 16), and that the ratio of the first width (a1) and the third width (b1) is greater than the ratio of the second width (a2) and the fourth width (b2).

GM, KE, LR, LS, MW, MZ, NA, RW, SD, SL, ST, SZ, TZ,
UG, ZM, ZW), Eurasian (AM, AZ, BY, KG, KZ, RU, TJ,
TM), European (AL, AT, BE, BG, CH, CY, CZ, DE, DK,
EE, ES, FI, FR, GB, GR, HR, HU, IE, IS, IT, LT, LU, LV,
MC, MK, MT, NL, NO, PL, PT, RO, RS, SE, SI, SK, SM,
TR), OAPI (BF, BJ, CF, CG, CI, CM, GA, GN, GQ, GW,
KM, ML, MR, NE, SN, TD, TG).

Declarations under Rule 4.17:

- *as to applicant's entitlement to apply for and be granted a patent (Rule 4.17(ii))*

Published:

- *with international search report (Art. 21(3))*

ABSORBENT ARTICLE WITH REDUCED SAGGING AND METHOD FOR MANUFACTURING THE ABSORBENT ARTICLE

TECHNICAL FIELD

5 The disclosure relates to an absorbent article comprising an absorbent core sandwiched between a liquid-permeable topsheet and a liquid-impermeable backsheet.

The disclosure also relates to an absorbent core for an absorbent article, and a method for manufacturing an absorbent article of the above-mentioned type.

10

BACKGROUND

Wearable and disposable absorbent articles, for example in the form of diapers, incontinence garments, feminine garments and the like, are well known. Such articles are used to absorb, distribute and store various types of body exudates while providing a high
15 level of comfort and sense of dryness to the wearer during use.

A conventional disposable absorbent article in the form of a diaper is normally designed with an absorbent core which is sandwiched between a topsheet and a backsheet. The article is arranged along a longitudinal axis and along a transversal axis which extends in
20 a perpendicular direction in relation to the longitudinal axis. Furthermore, the article can be divided into a front portion, a back portion and a crotch portion.

The absorbent article will absorb body exudates when it is worn. A potential disadvantage which may occur when the absorbent article is in its wet condition is that the crotch portion
25 may sag and hang down. This tendency for sagging is unwanted and may lead to insufficient comfort, fit and function of the article.

US 2012/316528 discloses a disposable diaper having an absorbent core which, according to an embodiment, comprises longitudinally extending and generally straight
30 channels.

SUMMARY

The present disclosure is based on the insight that the stiffness of the crotch portion of an absorbent article, for example a diaper, may be influenced by certain features of the article.

5 In one aspect there is provided an absorbent article comprising an absorbent core sandwiched between a liquid-permeable topsheet and a liquid-impermeable backsheet, said article being arranged along a longitudinal axis and a transversal axis extending in a perpendicular direction in relation to the longitudinal axis and said article defining a front portion, a back portion and a crotch portion, wherein said absorbent core comprises an absorbent component
10 enclosed by a core cover comprising an upper side and a lower side, and a sealing arrangement for joining said upper and lower sides and comprising two channel sealings, in the crotch portion, defining a first channel sealing width and a second channel sealing width, and also comprising two side seams along the sides of said core, wherein a centre segment having a first width is defined in the absorbent component between the channel sealings and
15 two side segments each having a second width are defined in the absorbent component outside each channel sealing. Furthermore, the absorbent component is formed so that the total amount of absorbent material in the centre segment is generally equal to, or greater than, the total amount of absorbent material in each one of the side segments, that a third width is defined between the channel sealings and a fourth width is defined between a channel sealing
20 and a side seam, and that the ratio of the first width and the third width is greater than the ratio of the second width and the fourth width.

The disclosure provides certain advantages. The disclosure fulfills requirements on absorbent articles related to improved fit, comfort and function in its wet condition. There is provided an
25 absorbent article in which the crotch portion, and in particular the central segment of the absorbent core, is configured with an increased stiffness as compared with the remaining parts of the absorbent core. The fact that the ratio of the of the first width and the third width is greater than the ratio of the second width and the fourth width means that the absorbent material in the centre segment will be more dense and stiff than the above-mentioned side
30 segments when the article is in a wet condition. This stiffness

of the centre segment will counteract the tendency for the crotch portion to sag during use. This means that improvements regarding fit, comfort and function will be obtained.

The absorbent article may be configured so that 33-41% by weight of the total amount of absorbent material in the crotch portion is in the centre segment and 25-33% by weight of the total absorbent material in the crotch portion may be in each one of the side segments. This leads to a suitable stiffness of the crotch portion, in particular as regards the centre segment.

- 10 The absorbent material in said crotch portion may comprise pulp material and superabsorbent material wherein said pulp material may have a basis weight which is in the interval of 50-400 g/m² and said superabsorbent material may have a basis weight which is in the interval of 100-900 g/m².
- 15 The absorbent material in said crotch portion may be constituted by 50-100 % by weight superabsorbent material and 0-50 % by weight pulp material.

The ratio of the first width and the third width may be in the interval 0,75 – 0,91, such as 0,80 – 0,86 and the ratio of the second width (a2) and the fourth width (b2) may be in the interval 0,57 – 0,71, such as 0,62 – 0,66.

Said first, second, third and fourth widths may be configured so that $b1 < b2 * 2$ and $a1 < a2 * 2$.

- 25 The centre segment may be configured for a stiffness in a wet condition which is greater than that of each side segment.

Each one of said channel sealings may have a length which is between 5-50%, such as 10-50%, such as 28-38%, of the total length of said article.

30

Each channel sealing may have a length which is between 10-60%, such as between 10-60%, such as between 20-60%, such as between 30-50%, of the length of the absorbent core.

The position of the channel sealings along the longitudinal direction of the article may be arranged so that the distance between the front edge of the main article and the front edge of each channel is between 15-40%, such as between 22-25%, of the total length of the article.

5

Said absorbent core may be constituted by one single core layer being wrapped in said core cover.

Said core cover may be configured with a basis weight which is in the interval 5-20 g/m².

10

The absorbent component may be configured with an ability to expand on wetting and displaying a first volume in dry condition and a second volume in completely expanded wet condition, the second volume being greater than the first volume.

15 The absorbent component after wetting has a greater stiffness than in dry condition and thus forms a forming element in the absorbent article.

The side segments may comprise at least one additive material in the form of a skin care composition.

20

The absorbent core may be rectangular. Also, the channel sealings may be generally straight. Also, the channel sealings may be generally parallel to said longitudinal axis.

The channel sealings may be positioned within two corresponding channels which
25 constitute sections of the absorbent core which are generally free from absorbent material.

The sealing arrangement may be constituted by a welding pattern which may be produced by means of a thermo and/or mechanical sealing method. The thermo and/or mechanical
30 sealing may be ultrasonic welding or thermo sealing.

The welding pattern may comprise a plurality of welding spots arranged in the form of a first row in which the welding spots extend along a first axis and a second row in which the welding spots extend along a second axis, said first axis and second axis defining a
35 first angle in relation to each other.

Said first angle may be 45-130°, such as 45-100°, such as 45-70°. Also, said welding spots may be generally rectangular, oval or oblong.

- 5 Said first axis may define a second angle with reference to said longitudinal axis which is within the interval 30-60°.

The channel sealings may extend along said longitudinal axis in said crotch portion and may define a first effective channel sealing width and a second effective channel sealing
10 width, and the side seams may define a third and fourth effective width, respectively, along said crotch portion and defining a fifth and sixth effective width, respectively, along said front portion and back portion; said effective widths being defined as the extension of said sealing arrangement in the transverse direction of the article, along any cross-section
15 of the crotch portion, wherein the sum of said first to sixth effective widths in a transversal direction may be generally constant along said core.

There is also provided absorbent core for an absorbent article, said absorbent core comprising an absorbent component enclosed by a core cover comprising an upper and a lower side, and a sealing arrangement for joining said upper and lower sides, and also
20 comprising two channel sealings, in a crotch portion, defining a first channel sealing width and a second channel sealing width, and also comprising two side seams along the sides of said core, wherein a centre segment having a first width is defined between the channel sealings and two side segments each having a second width are defined outside each channel sealing. Furthermore, the absorbent component is formed so that the total
25 amount of absorbent material in the centre segment is generally equal to, or greater than, the total amount of absorbent material in each one of the side segments, that a third width is defined between the channel sealings and a fourth width is defined between a channel sealing and a side seam, and that the ratio of the first width and the third width is greater than the ratio of the second width and the fourth width.

30

There is also provided a method for manufacturing an absorbent article, the article comprising a longitudinal axis and a transversal axis extending in a perpendicular direction in relation to the longitudinal axis and said article defining a front portion, a back portion and a crotch portion. The method comprising forming an absorbent core with an
35 absorbent component enclosed by a core cover comprising an upper side and a lower

side; providing a sealing arrangement comprising two channel sealings and two side seams joining said upper and lower core cover sides; defining, in said absorbent component a centre segment between the channel sealings and two side segments outside each channel sealing, said centre segment having a first width and each side segment having a second width; and sandwiching said absorbent core between a liquid-permeable topsheet and a liquid-impermeable backsheet, forming said absorbent component so that the total amount of absorbent material in the centre segment is generally equal to, or greater than, the total amount of absorbent material in each one of the side segments; forming said core with a third width between the channel sealings and a fourth width between a channel sealing and a side seam; and forming said core so that that the ratio of the first width and the third width is greater than the ratio of the second width and the fourth width.

Further advantages and advantageous features of the disclosure are disclosed in the following description and in the dependent claims.

BRIEF DESCRIPTION OF THE DRAWINGS

The disclosure will be described in greater detail below with reference to the figures shown in the appended drawings, wherein

Figure 1 shows a view from above of an absorbent article in the form of a diaper;

Figure 2 shows a cross-sectional view of the diaper;

25

Figure 3 shows a view from above of an absorbent core intended to be used in said diaper shown in Figures 1 and 2;

Figure 4 shows a welding pattern which can be implemented in the invention; and

30

Figure 5 shows a further view of a welding pattern.

35

DETAILED DESCRIPTION

Different aspects of the present disclosure will be described more fully hereinafter with reference to the enclosed drawings. The embodiments disclosed herein can, however, be realized in many different forms and should not be construed as being limited to the
5 aspects set forth herein.

With initial reference to Fig. 1, there is shown a view from above of an absorbent article 1 in the form of a baby diaper. The absorbent article 1 is shown in Fig. 1 in an unfolded and flat state. Also, the absorbent article 1 is based on an absorbent structure for absorbing
10 body exudates from a wearer to provide a dry and comfortable fit for the wearer.

As shown in Fig. 1, the absorbent article 1 comprises a liquid-permeable topsheet 3, a liquid-impermeable backsheet 4 an absorbent core 5 which is sandwiched between the topsheet 3 and the backsheet 4. The topsheet 3 is arranged at the surface of the article 1,
15 i.e. at the side which is facing the wearer, whereas the backsheet 4 is arranged at the underside of the article 1. Furthermore, both the topsheet 3 and the backsheet 4 may extend laterally outside of the absorbent core 5 along the entire perimeter of the article 1.

The absorbent core shown in Figure 1 has a rectangular design. However, the disclosure
20 is not limited to this design but may be formed in generally any geometric form within the scope of the invention.

The topsheet 3, backsheet 4 and the absorbent core 5 may consist of any materials suitable for their purposes, as will be discussed in further detail below.
25

As shown in Fig. 1, the absorbent article 1 has a longitudinal extension along a longitudinal axis y_1 and a transverse extension along a transverse axis x_1 , which is perpendicular to the longitudinal axis y_1 . Furthermore, the absorbent article 1 may be defined as being divided into a front portion 6, a back portion 7 and a crotch portion 8. The
30 front 6 and back portions each having a waist edge 2. The front portion 6 is intended to be oriented in a direction towards the wearer's belly during use of the article 1.

Furthermore, with reference to Figs. 1 and 2, wherein Fig. 2 is a cross-sectional view of the absorbent article 1 along the transversal axis x_1 , it should be noted that the absorbent
35 core 5 comprises an absorbent component 5a, 5b, 5c which is sandwiched between an

upper core cover side 11 and a lower core cover side 12, and is formed with two longitudinally extending and generally straight channel sealings 9, 10 which are configured so as to join the upper core cover side 11 to the lower core cover side 12, see in particular Fig. 2, wherein the absorbent core 5 is sandwiched between said upper core cover side 11 and said lower core cover side 12. The disclosure is not limited to a core wrap comprising two core cover layers. The core cover may be of one single material layer. The absorbent component may be enclosed by one core cover layer folded in two, or enclosed by a continuous core cover sheet, thereby providing upper and lower core cover sides for wrapping the absorbent component.

10

The upper core cover side 11 and the lower core cover side 12 may be attached to each other by various technologies, for example, by thermo and/or mechanical bonding, such as thermo-sealing, ultrasonic bonding and in combination with an adhesive or adhesives, stitching or the like. According to Figs. 1 and 2, the upper core cover side 11 and the lower core cover side 12 are attached to each other by ultrasonic welding.

The channel sealings 9, 10 are positioned along two corresponding channels 13, 14 which constitute sections of the absorbent core 5 which are not filled with absorbent material. This may be obtained through manufacturing the absorbent core 5 involving a mat forming process during which absorbent material is omitted from the areas which correspond to the channels 13, 14. In this manner, no absorbent material will be present in the channels 13, 14, i.e. where the channel sealings 9, 10 are arranged.

As shown in Figs. 1 and 2, the absorbent core 5 may be divided into a centre segment 5a and two side segments 5b, 5c in the crotch portion 8. The two above-mentioned channels 13, 14, and the channel sealings 9, 10 will consequently be configured so that they separate the three segments 5a, 5b, 5c from each other along the crotch area 8. Also, the length l1 of each channel sealing 9, 10 may correspond to the length of the crotch portion 8 and may also be slightly less than the length of each channel 13, 14.

30

The absorbent core 5 may be generally rectangular and comprise two generally straight channel sealings 9, 10 which are generally parallel to said longitudinal axis y1 and define a first channel sealing width w1 and a second channel sealing width w2. The disclosure is not limited to a rectangular core 5 and generally straight channel sealings 9, 10, i.e. other geometrical configurations may occur. The channel sealings 9, 10 are positioned within

35

the first channel 13 and the second channel 14, respectively, and are configured to attach the upper core cover side 11 to the lower core cover side 12.

Furthermore, the centre segment 5a comprising absorbent material is defined in the core 5 between the channel sealings 9, 10. Also, the two side segments 5b, 5c comprising absorbent material are defined in the core 5 outside each channel sealing 9, 10. More precisely, the first side segment 5b is positioned between the first channel sealing 9 and a first side seam 15, whereas the second side segment 5c is positioned between the second channel sealing 10 and a second side seam 16. The side seams 15, 16 are configured for joining the upper core cover side 11 to the lower core cover side 12, suitably by means of ultrasonic welding or other relevant technologies as described above with reference to the channel sealings 9, 10. Furthermore, the side seams 15, 16 extend along each side of the absorbent core 5, along a first side edge 17 and a second side edge 18 of the absorbent core 5.

15

As mentioned, the length l1 of the crotch portion 8 may equal the length of the channel sealings 9, 10, i.e. the channel sealings 9, 10 may extend along the crotch portion 8 only. However, the side seams 15, 16 may not just be positioned along the crotch portion 8 but also extend along the front portion 6 and the back portion 7. This will be described in detail below.

20

In summary, the absorbent core 5 is formed with a sealing arrangement which is constituted by the two channel sealings 9, 10 and the two side seams 15, 16. The sealing arrangement is configured so that, in the crotch portion 8, the absorbent core 5 is divided into a centre segment 5a comprising absorbent material and two side segments 5b, 5c comprising absorbent material. More precisely, and as shown in Fig. 2, the centre segment 5a has a first width a1 and each side segment 5b, 5c has a second width a2. Also, a third width b1 is defined between the two channel sealings 9, 10. Furthermore, a fourth width b2 is defined between the first channel sealing 9 and the first side seam 15, and also between the second channel sealing 10 and the second side seam 16.

30

According to Figs. 1 and 2, the absorbent component 5a, 5b 5c is configured so that the total amount of absorbent material of the centre segment 5a is generally equal to or greater than the total amount of absorbent material in each one of the side segments 5b, 5c. As will be described in greater detail below, the absorbent material may comprise a

35

mixture of pulp material and superabsorbent material. Also, the ratio of the first width a_1 and the third width b_1 is greater than the ratio of the second width a_2 and the fourth width b_2 . In practical terms, this means that the available space for expansion of the absorbent material in the centre segment 5a, during use of the absorbent article 1 in its wet condition, is less than the corresponding available space for each side segment 5b, 5c. This will lead to a situation in which the centre segment 5a will be stiffer (in its wet condition) than the side segments 5b, 5c. This means that any tendency in the crotch portion 8 of the absorbent article 1 to sag will be reduced, in particular in its wet condition.

10 The expression "generally equal" as used above for describing the amount of absorbent material in the centre segment 5a as compared with the side segments 5b, 5c should be interpreted in a manner wherein the amount of absorbent material could have a variation of approximately $\pm 5\%$ in any part of the crotch portion 8.

15 The absorbent article 1 may be configured so that 33-41% by weight of the total amount of absorbent material in the crotch portion 8 is in the centre segment 5a, whereas 25-33% by weight of the total absorbent material in the crotch portion 8 is in each one of the side segments 5b, 5c. In this manner, the desired stiffness in the centre segment 5a may be obtained.

20

In summary, the absorbent core 5 comprises an absorbent component which in turn comprises the three above-mentioned segments 5a, 5b, 5c in the crotch portion 8 of the absorbent article 1. In the crotch portion 8, the absorbent component 5a, 5b, 5c comprises absorbent material which may be in the form of pulp material and superabsorbent material. The pulp material may have a basis weight which is in the interval of 50-400 g/m^2 and the superabsorbent material may have a basis weight which is in the interval of 100-900 g/m^2 . However, a deviation of $\pm 5\%$ of the chosen basis weight in the crotch portion 8 is accepted to obtain the purpose of providing a sufficiently stiff centre segment 5a and a reduction of the tendency for the article 1 to sag, as described above.

30

Various types of materials may be used for the absorbent article 1. The topsheet 3 is arranged to face the wearer of the absorbent article 1 when worn. The topsheet 3 may be formed by a fluid permeable nonwoven fabric or film which is made of thermoplastic synthetic fibers. The topsheet 3 may be sufficiently liquid-permeable to allow discharged body fluids to penetrate through the thickness of the topsheet 3. Also, the topsheet 3 may

be suitably manufactured from a material which is compliant and soft-feeling to the skin of the wearer. The topsheet 3 may consist of a single layer or have a laminate structure comprising a plurality of layers, for example, two or more layers. The layers may be made of the same material, or some or all the layers may be made of different materials.

5

The layer of the topsheet 3 or, for the case of a laminate structure, one, some, or all layers of the topsheet may be made of a single material or have plural portions made of different materials, e.g., within different parts of the wearer-facing surface of the topsheet.

10 The layer of the topsheet 3 or, for the case of a laminate structure, one, some or all layers of the topsheet may be a nonwoven material, a perforated plastic film, a plastic or textile mesh, or a liquid permeable foam layer.

The layer of the topsheet 3 or, for the case of a laminate structure, one, some, or all of the
15 layers of the topsheet may be, for example, a hydrophilic, non-apertured nonwoven web of fibers, such as natural fibers, e.g., cotton or pulp fibers, synthetic fibers, e.g., polyester or polypropylene fibers, or a combination of these fibers.

The topsheet may have a basis weight in the range of 8-40 g/m². However, the disclosure
20 is not limited to topsheets having this basis weight only.

Furthermore, the backsheet 4 may be constituted by a liquid-impermeable and breathable layer such as a polymeric film, for example a film of polyethylene or polypropylene.

According to different embodiments, the materials which may be used for the backsheet 4
25 include thin and flexible fluid impermeable plastic films, or fluid impermeable nonwoven materials, fluid impermeable foams and fluid impermeable laminates.

The backsheet 4 may be formed by a single layer, but may alternatively be formed by a multi-layered structure, i.e. a laminate, wherein at least one layer is fluid impermeable.

30 Furthermore, the backsheet 4 may be elastic in any direction.

Furthermore, the backsheet 4 may have a laminate structure comprising a liquid barrier sheet and a nonwoven layer arranged on top of each other (not shown in detail in the drawings), wherein the nonwoven layer is arranged at an outer side away from the wearer
35 of the absorbent article 1 when worn.

The nonwoven layer may be made of thermoplastic polymer material fibers or filaments. The nonwoven layer may be formed by a variety of different processes, such as spunbonding, airlaying, meltblowing or bonded carded web formation processes. The
5 nonwoven layer may be made of an SMS (spunbond/meltblown/spunbond) or SS (spunbond/ spunbond) nonwoven material of polypropylene or bicomponent fibers of polypropylene and polyethylene, or of a combination of such materials. The nonwoven layer may have a basis weight in the range of 5-40 g/m².

10 The liquid barrier sheet may be made of a plastic material, for example a thermoplastic film material, and/or a nonwoven material. For example, the liquid barrier sheet may be formed as a plastic layer, e.g., a thermoplastic layer, or a plastic film, e.g., a thermoplastic film. Forming the liquid barrier sheet of a plastic material, such as a thermoplastic film material, allows for a particularly good printability of the liquid barrier sheet. The liquid
15 barrier sheet may also contain paper fibers.

The liquid barrier sheet may be a liquid impermeable, breathable or non-breathable layer. The liquid barrier sheet may consist of a single layer or have a laminate structure with a plurality of layers, e.g., two or more layers, three or more layers, or four or more layers.
20 The layers of the liquid barrier sheet may be laminated, bonded or attached to each other, for example, by thermo and/or mechanical bonding, such as thermo-sealing, ultrasonic bonding, such as ultrasonic welding, an adhesive or adhesives, stitching or the like.

The liquid barrier sheet may be a breathable microporous film. The microporous film may
25 be made of a material comprising at least two basic components, namely a thermoplastic elastomeric polyolefin polymer and a filler. These components and, in some embodiments, additional other components may be mixed together, heated and subsequently extruded into a mono-layer or multi-layer film using any one of various film-producing processes, such as cast embossed, chill and flat cast, and blown film
30 processes.

Regarding the choice of materials for the various layers in the absorbent article, the materials may be chosen for the bonding process to form the channel sealings and side seams. For example, if ultrasonic welding is chosen for joining the upper and lower core

cover sides, the chosen materials for the core cover may be adapted to form a secure bond during ultrasonic welding.

Furthermore, the absorbent core 5 is provided between the topsheet 3 and the backsheet 4 to absorb the liquid, such as urine or other bodily fluids, which has passed through the topsheet 3. The absorbent core 5 may be made of one layer only, made from any suitable absorbent or liquid uptake material, such as one or more layers of cellulose fluff pulp, foam, fiber waddings or the like.

- 10 The absorbent core 5 may comprise suitable amounts of superabsorbent particles. Such superabsorbent material is well known in the field of absorbent articles, and is constituted by a water-swallowable and water-insoluble material which is capable of absorbing large quantities of fluid upon formation of a hydrogel. The absorbent core 5 may contain superabsorbent material in the form of fibers or particles of absorbent polymer material.
- 15 For example, the superabsorbent material may be surface cross-linked, partially neutralized polyacrylates.

Furthermore, the core cover 11, 12 as mentioned above may be made of nonwoven material, with a basis weight of 5-20 g/m². The nonwoven material may be of thermoplastic polymer fibers or filaments. The nonwoven may be formed by a variety of different processes such as spunbonding, airlaying, meltblowing or bonded carded web formation processes. The core cover may be of an SMS (spunbond/meltblown/spunbond) or SS (spunbond/spunbond) nonwoven material and may be of polypropylene or bicomponent fibers of polypropylene and polyethylene, or of a combination of the same.

25 The superabsorbent material, e.g., the superabsorbent fibers or particles, may be mixed with other absorbent or liquid uptake material or materials, such as cellulose fluff pulp, and/or arranged in pockets or layers in the absorbent core 5. The amount of superabsorbent material and pulp in the absorbent core 5 may be 0-50 % by weight pulp fibers and 50-100 % by weight superabsorbent material.

30

The absorbent core 5 may further comprise components for improving the properties of the absorbent core 5. For example, the absorbent core 5 may comprise a binder or binders, such as binder fibers.

35

Furthermore, as known by the skilled person, the various layers of the absorbent article 1 may be attached by means of adhesive material. Such adhesive is not shown in the drawings.

- 5 One or more additional layers may be provided in the absorbent article 1. For example, an acquisition layer may be arranged between the absorbent core 4 and the topsheet 3. Such an additional layer may for example be in the form of an airlaid layer, a spunlace layer, a high-loft, foam or any other type of material layer which may be used in an absorbent article to act as a liquid acquisition and absorption layer. The acquisition layer
10 is adapted to quickly receive and temporarily store discharged liquid before it is absorbed by the absorbent core. Such acquisition layer may be composed of for example airlaid nonwoven, spunlace nonwoven, high loft nonwoven or foam materials. An airlaid nonwoven may be produced with fluff, wood pulp, and here the fluff fibres are dispersed into a fast-moving air stream and condensed onto a moving screen by means of pressure
15 and vacuum.

According to an embodiment, the ratio of the first width a_1 of the centre segment 5a and the third width b_1 , i.e. the distance between the channel sealings 9, 10 (i.e. a_1/b_1) is in the interval 0,75 – 0,91, such as 0,80 – 0,86. Furthermore, the ratio of the second width
20 a_2 of each side segment 5b, 5c and the fourth width b_2 , i.e. the distance between each channel sealing 9, 10 and its corresponding, adjacent side seam 11, 12 (i.e. a_2/b_2) is in the interval 0,57 – 0,71, such as 0,62 – 0,66. In this manner, the required stiffness of the centre segment 5a may be obtained.

- 25 In general, the article 1 is arranged so that the ratio of the first width a_1 and the third width b_1 is greater than the ratio of the second width a_2 and the fourth width b_2 , i.e.

$$(a_1/b_1) > (a_2/b_2)$$

- 30 Furthermore, the first, second, third and fourth widths a_1 , a_2 , b_1 , b_2 , respectively, may be configured so that:

$$b_1 < b_2 * 2 \text{ and } a_1 < a_2 * 2$$

In addition to the arrangement of the first, second, third and fourth widths a_1 , a_2 , b_1 , b_2 , as described above, the absorbent article 1 is arranged to provide the desired stiffness of the centre segment 5a and the entire absorbent article 1 by the above-mentioned arrangement of the absorbent material in the absorbent core 5. This means that the
5 centre segment 5a is configured for a stiffness in a wet condition which is greater than that of each side segment 5b, 5c. This also means that the absorbent component, i.e. consisting of the centre segment 5a and the side segments 5b, 5c, may be configured with an ability to expand on wetting and to display a first volume in dry condition and a second volume in completely expanded wet condition, the second volume being greater
10 than the first volume.

With reference again to Fig. 1, it can be noted that each channel sealing 9, 10 may have a length l_1 which corresponds to the longitudinal extension of the crotch portion 8. Each one of the channel sealings 9, 10 may have a length l_1 which is between 5-50%, such as 10-
15 50%, such as 28-38%, of the total length l of the absorbent article 1. Furthermore, each channel sealing 9, 10 may have a length l_1 which is between 10-60%, such as between 20-60%, such as between 30-50%, of the length of the absorbent core 5.

A further parameter is the positioning of the channel sealings 9, 10 along the absorbent
20 article 1 in its longitudinal direction. Such positioning may be defined by choosing a suitable value for the distance l_2 between the front edge 19 of the article 1 and the front edge 20 of each channel sealing 9, 10. Obviously, this means that decreasing said distance l_2 means that the distance l_3 between the back edge 21 of the article 1 and the back edge 22 of the channel sealings 9, 10 will be increased, and vice versa.

25 The position of the channel sealings 9, 10 along the longitudinal direction of the absorbent article 1 may be chosen in a manner so that the distance l_2 between the front edge 19 of the article 1 and the front edge 20 of each channel 9, 10 is between 15-40%, such as between 22-25%, of the total length l of the article 1.

30 As mentioned above, the absorbent core 5 is sandwiched between an upper core cover side 11 and a lower core cover side 12. The absorbent core 5 may be manufactured as a single layer which is wrapped in nonwoven material and positioned between the topsheet 3 and the backsheet 4 during manufacturing of the absorbent article 1.

35

Furthermore, the absorbent core 5 may comprise at least one additive material such as a skin care composition. It may be an advantage if the side segments 5b, 5c comprise at least one additive material in the form of a skin care composition. This is due to the side segments 5b, 5c normally will be closest to the body of the wearer of the absorbent article 1. The additive may be located on the parts of the topsheet covering the side segments 5b, 5c.

According to what is known to the skilled person, the absorbent article 1 may additionally be provided with further components such as fastening tabs, elastic elements and other components which are commonly used in absorbent articles such as for example baby diapers or incontinence garments. Such additional components are not described in detail here.

With reference to Fig. 1 an absorbent core 5 is provided with a sealing arrangement 9, 10, 15 15, 16, i.e. comprising the above-mentioned channel sealings 9, 10 and the side seams 15, 16. As shown in Fig. 3, the side seams 15, 16 extend along the side edges 17, 18 of the core.

The side seams 15,16 may define a first side seam width w_3 and a second side seam width w_4 , respectively, along the crotch portion 8 of the absorbent article 1.

As shown in Fig. 1, the channel sealings 9, 10 may be generally straight and generally parallel to the longitudinal axis x_1 . Also, the side seams 15, 16 may be generally straight and generally parallel to the longitudinal axis x_1 .

25

With reference to Fig. 3 and 4, the sealing arrangement 9, 10, 15, 16 may be constituted by a welding pattern 23 produced by means of ultrasonic welding. The welding pattern 23 may comprise welding spots 24 which are arranged in the form of a first row 23a in which the welding spots 24 are arranged along a first axis 25. Also, a further number of welding spots 24 are arranged in the form of a second row 23b in which the welding spots 24 extend along a second axis 26. Furthermore, the first axis 25 and the second axis 26 extend in a manner so that they define a first angle α_1 in relation to each other. In this manner, it can be ensured that the absorbent core 5 can be manufactured with a high level of material strength in both its longitudinal and transversal direction.

35

The welding spots 24 may be of generally rectangular, oval or oblong shape. Also, the above-mentioned first angle α_1 may be in the interval of 45-130°. As shown in Fig. 4, the first angle α_1 may be in the magnitude of 90°.

- 5 Also, as shown in Fig. 4, the first axis 25 may define an angle α_2 with reference to said longitudinal axis y_1 which is within the interval 30-60°.

Fig. 4 teaches one row 23c of welding spots in each side seam 15, 16 along the crotch portion 8, and three rows 23c, 23d, 23e of welding spots in each side seam 15, 16 along
10 the front portion 6 and the back portion 7, respectively. Also, each side seam 15, 16 may define a fifth side seam width w_5 and a sixth side seam width w_6 along the front portion 6 and back portion 7, respectively.

As shown in Fig. 3 and 4, the width w_2 of the first row 23a and the second row 23b may
15 be defined as an "effective" width in the sense that it is equal to the sum of an effective width w_{2a} of a welding spot 24 in the first row 23a and an effective width w_{2b} of a welding spot 24 in the second row 23b. Each "effective width" can be defined as the length of a welding spot 24 in a transverse direction of the article 1, as indicated in Fig. 4. Similarly, the effective width w_4 and w_6 , respectively, of the third row 23c of welding spots 24 is
20 also shown in Fig. 4. The effective width of the third row 23c in the crotch portion 8 is the length w_4 of a welding spot 24 in said transverse direction, as indicated in Fig. 4. Also, the effective width w_6 of the third row 23c outside the crotch portion 8 (as also indicated in Fig. 3) is the sum of the lengths w_{6a} , w_{6b} , w_{6c} in said transverse direction, as shown in Fig. 4.

25

The sum of the effective channel sealing widths w_1 , w_2 and the first and second side seam widths w_3 , w_4 , w_5 , w_6 in a transversal direction of the article 1 may be generally constant along the longitudinal length of the core 5. This is particularly advantageous in a manufacturing process involving ultrasonic welding of the channels sealings 9, 10 and the
30 side seams 15, 16, since the manufacturing process can be arranged so that a generally constant energy is required as the ultrasonic welding of the channels sealings 9, 10 and side seams 15, 16 is produced along the longitudinal direction of the core 5.

A method for manufacturing an absorbent article 1 will now be described. Firstly, the
35 absorbent core 5 is formed by an absorbent component 5a, 5b, 5c and enclosing said

absorbent component 5a, 5b, 5c between the upper core cover side 11 and the lower core cover side 12. Next, the sealing arrangement, i.e. the channel sealings 9, 10 and the side seams 15, 16), are formed in a manner so that they join the upper core cover side 11 and the lower core cover side 12. As described above, the sealing arrangement 9, 10, 15, 16
5 may be formed by ultrasonic welding.

Consequently, the absorbent core 5 is formed with an absorbent component 5a, 5b, 5c enclosed by a core cover 11, 12 and the sealing arrangement 9, 10, 15, 16 comprising the two channel sealings 9, 10 and the side seams 15, 16. The upper core cover side 11 and
10 the lower core cover side 12 are joined to define said sealing arrangement 9, 10, 15, 16.

The absorbent core 5 and the sealing arrangement 9, 10, 15, 16 is formed in a manner so that the centre segment 5a is formed between the channel sealings 9, 10 and the two side segments 5b, 5c are formed outside each channel sealing 9, 10. More precisely, the
15 centre segment 5a comprising absorbent material has a first width a_1 and each side segment 5b, 5c comprising absorbent material has a second width a_2 . Also, the core 5 is formed with a third width b_1 between the channel sealings 9, 10 and a fourth width b_2 between a channel sealing 9, 10 and a side seam 15, 16.

20 The article 1 (see Fig. 1) is formed by sandwiching the absorbent core 5 between the liquid-permeable topsheet 3 and the liquid-impermeable backsheet 4. The article 1 defines the longitudinal axis y_1 and the transversal axis x_1 as described above. Also, the article 1 defines a front portion 6, a back portion 7 and a crotch portion 8. Furthermore, the channel sealings 9, 10 are positioned in the crotch portion 8, i.e. the length l_1 of each
25 channel sealing 9, 10 may correspond to the extension of the crotch portion 8.

The absorbent component 5 is formed so that the total amount of absorbent material of the centre segment 5a is generally equal to, or greater than, the total amount of absorbent material in each one of the side segments 5b, 5c. Furthermore, the manufacture method
30 is configured so that the absorbent core 5 is formed so that that the ratio of the first width a_1 and the third width b_1 is greater than the ratio of the second width a_2 and the fourth width b_2 . This corresponds to the description above with reference to Figs. 1 and 2.

The disclosure may be varied within the scope of the appended claims. For example, the
35 materials and dimensions used for the different layers forming the absorbent article 1 may

be varied, as indicated above. The absorbent article may further include leg elastics, standing gathers, crotch and waist elastics, side panels, fastening systems etc as known to the skilled man in the art and depending of the type of absorbent article intended.

- 5 In the claims which follow and in the preceding description of the invention, except where the context requires otherwise due to express language or necessary implication, the word “comprise” or variations such as “comprises” or “comprising” is used in an inclusive sense, i.e. to specify the presence of the stated features but not to preclude the presence or addition of further features in various embodiments of the invention.

10

It is to be understood that, if any prior art publication is referred to herein, such reference does not constitute an admission that the publication forms a part of the common general knowledge in the art, in Australia or any other country.

CLAIMS

1. An absorbent article comprising an absorbent core sandwiched between a liquid-permeable topsheet and a liquid-impermeable backsheet, said article being arranged along a longitudinal axis and a transversal axis extending in a perpendicular direction in relation to the longitudinal axis and said article comprising a front portion, a back portion and a crotch portion, wherein said absorbent core comprises an absorbent component enclosed by a core cover comprising an upper and a lower side, and sealing arrangement for joining said upper and lower sides and comprising two channel sealings extending along said longitudinal axis in the crotch portion, defining a first channel sealing width and a second channel sealing width, and also comprising two side seams along the sides of said core, wherein a center segment having a first width is defined in the absorbent component between the channel sealings and two side segments each having a second width are defined in the absorbent component outside each channel sealing, wherein the absorbent component is formed so that the total amount of absorbent material in the centre segment is generally equal to, or greater than, the total amount of absorbent material in each one of the side segments, that a third width is defined between the channel sealings and a fourth width is defined between a channel sealing and a side seam, and that the ratio of the first width and the third width is greater than the ratio of the second width and the fourth width.
2. An absorbent article according to claim 1, wherein the absorbent article is configured so that 33-41% by weight of the total amount of absorbent material in the crotch portion is in the centre segment and 25-33% by weight of the total absorbent material in the crotch portion is in each one of the side segments.
3. An absorbent article according to claim 1 or 2, wherein said absorbent material in said crotch portion comprises pulp material and superabsorbent material, said pulp material having a basis weight which is in the interval of 50-400 g/m² and said superabsorbent material having a basis weight which is in the interval of 100-900 g/m².
4. An absorbent article according to any one of the preceding claims, wherein said absorbent material in said crotch portion is constituted by 50-100 % by weight superabsorbent material and 0-50 % by weight pulp material.

5. An absorbent article according to any one of the preceding claims, wherein the ratio of the first width and the third width is in the interval 0.75–0.91, such as 0.80–0.86 and the ratio of the second width and the fourth width is in the interval 0.57–0.71, such as 0.62–0.66.
- 5
6. An absorbent article according to any one of the preceding claims, wherein said first, second, third and fourth widths are configured so that the third width $<$ the fourth width * 2 and the first width $<$ the second width * 2.
- 10
7. An absorbent article according to any one of the preceding claim, wherein each one of said channel sealings has a length which is between 5-50%, such as 10-50%, such as 28-38%, of the total length of said article.
8. An absorbent article according to any one of the preceding claims, wherein each
- 15 channel sealing has a length which is between 10-60%, such as between 20-60%, such as between 30-50%, of the length of the absorbent core.
9. An absorbent article according to any one of the preceding claims, wherein the position of the channel sealings along the longitudinal direction of the article is arranged so that
- 20 the distance between the front edge of the article and the front edge of each channel is between 15-40%, such as 22-25%, of the total length of the article.
10. An absorbent article according to any one of the preceding claims, wherein said core is constituted by one single core layer.
- 25
11. An absorbent article according to any one of the preceding claims, wherein said core cover material is configured with a basis weight which is in the interval 5-20 g/m².
12. An absorbent article according to any one of the preceding claims, wherein said
- 30 absorbent component is configured with an ability to expand on wetting and displaying a first volume in dry condition and a second volume in completely expanded wet condition, the second volume being greater than the first volume.

13. An absorbent article according to claim 12, wherein the centre segment after wetting has a greater stiffness than in dry condition and thus forms a forming element in the absorbent article.

5

14. An absorbent article according to any one of the preceding claims, wherein said side segments comprise at least one additive material in the form of a skin care composition.

15. An absorbent article according to any one of the preceding claims, wherein said
10 absorbent core is generally rectangular.

16. An absorbent article according to any one of the preceding claims, wherein said channel sealings are generally straight.

15 17. An absorbent article according to any one of the preceding claims, wherein said channel sealings are generally parallel to said longitudinal axis.

18. An absorbent article according to any one of the preceding claims, wherein said channel sealings are positioned within two corresponding channels which constitute
20 sections of the absorbent core which are generally free from absorbent material.

19. An absorbent article according to any one of the preceding claims, wherein the sealing arrangement is constituted by a welding pattern produced by means of a thermo and/or mechanical sealing method.

25

20. An absorbent article according to claim 19, wherein the welding pattern comprises a plurality of welding spots arranged in the form of a first row in which the welding spots extend along a first axis and a second row in which the welding spots extend along a second axis, said first axis and second axis defining a first angle in relation to each other.

30

21. An absorbent article according to claim 20, wherein said first angle is 45-130°.

22. An absorbent article according to claim 20 or 21, wherein said welding spots are generally rectangular, oval or oblong.

35

23. An absorbent article according to any one of claims 20-22, wherein said first axis defines a second angle with reference to said longitudinal axis which is within the interval 30-60°.

5 24. An absorbent article according to any one of the preceding claims, wherein the channel sealings extending along said longitudinal axis in said crotch portion and defining a first effective channel sealing width and a second effective channel sealing width, and wherein the side seams define a third and fourth effective width, respectively, along said crotch portion and defining a fifth and sixth effective width, respectively, along said front
10 portion and back portion; said first to sixth effective widths being defined as the extension of said sealing arrangement in the transverse direction of the article, along any cross-section of the crotch portion, wherein the sum of said first to sixth effective widths in a transversal direction is generally constant along said core.

15 25. An absorbent core for an absorbent article, said absorbent core comprising an absorbent component enclosed by a core cover comprising an upper side and a lower side, and a sealing arrangement for joining said upper and lower sides and also comprising two channel sealings extending along a longitudinal axis in a crotch portion, defining a first channel sealing width and a second channel sealing width, and also
20 comprising two side seams along the sides of said core, wherein a centre segment having a first width is defined between the channel sealings and two side segments each having a second width are defined outside each channel sealing, wherein the absorbent component is formed so that the total amount of absorbent material in the centre segment is generally equal to, or greater than, the total amount of absorbent material in each one
25 of the side segments, that a third width is defined between the channel sealings and a fourth width is defined between a channels sealing and a side seam, and that the ratio of the first width and the third width is greater than the ratio of the second width and the fourth width.

1/4

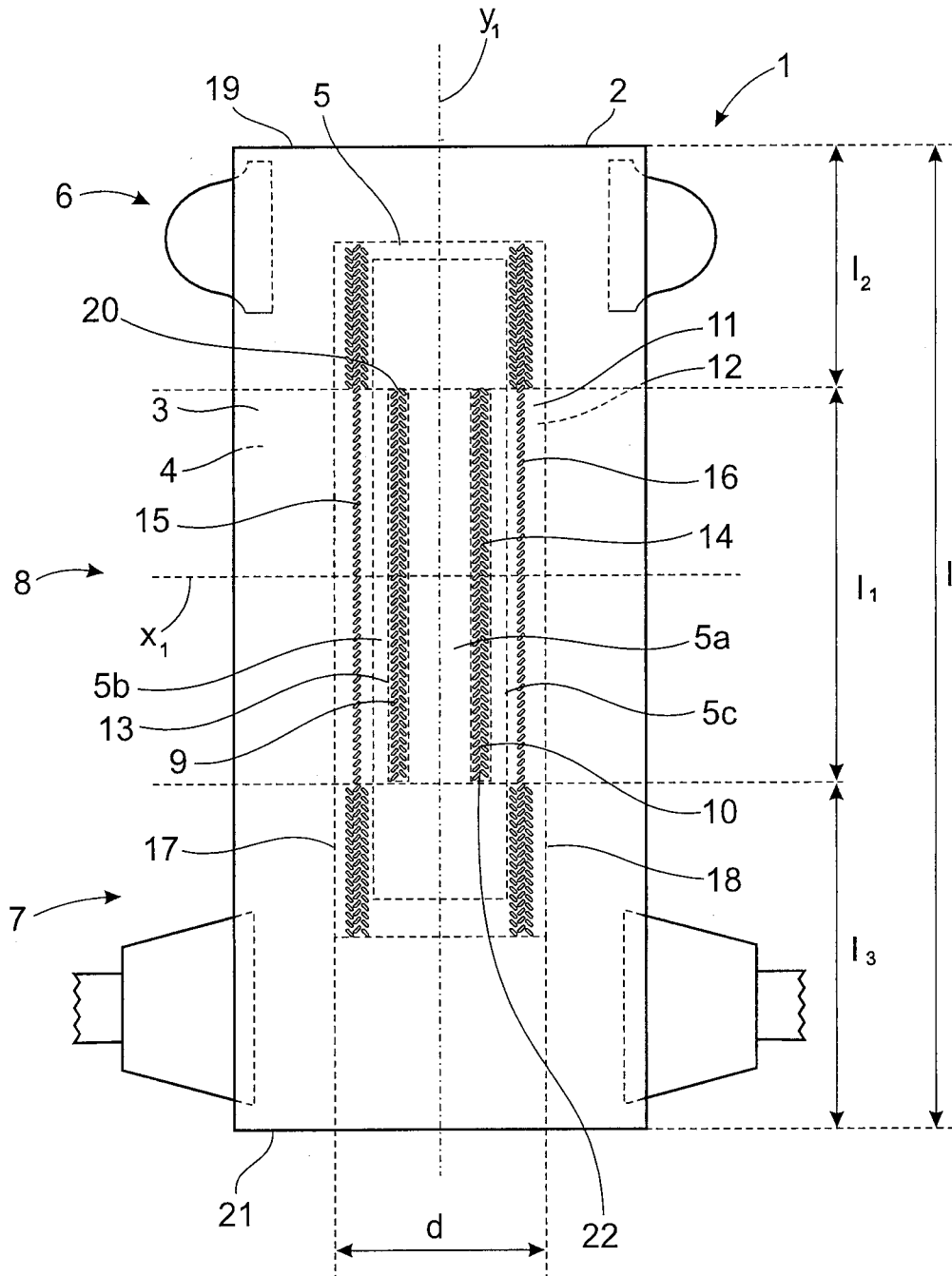

Fig.1

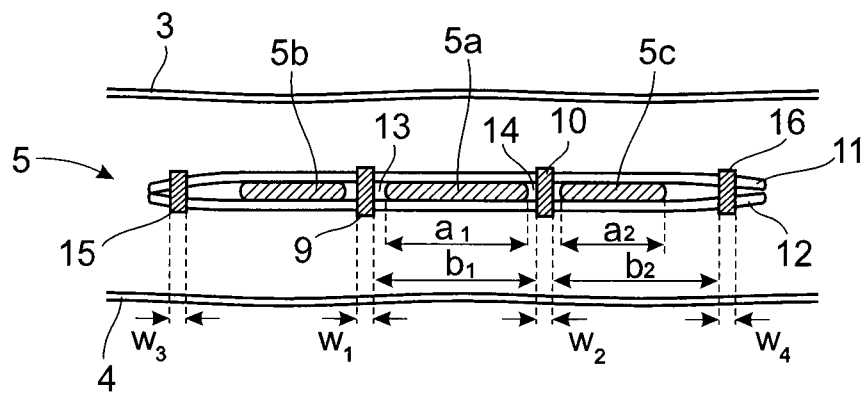

Fig.2

3/4

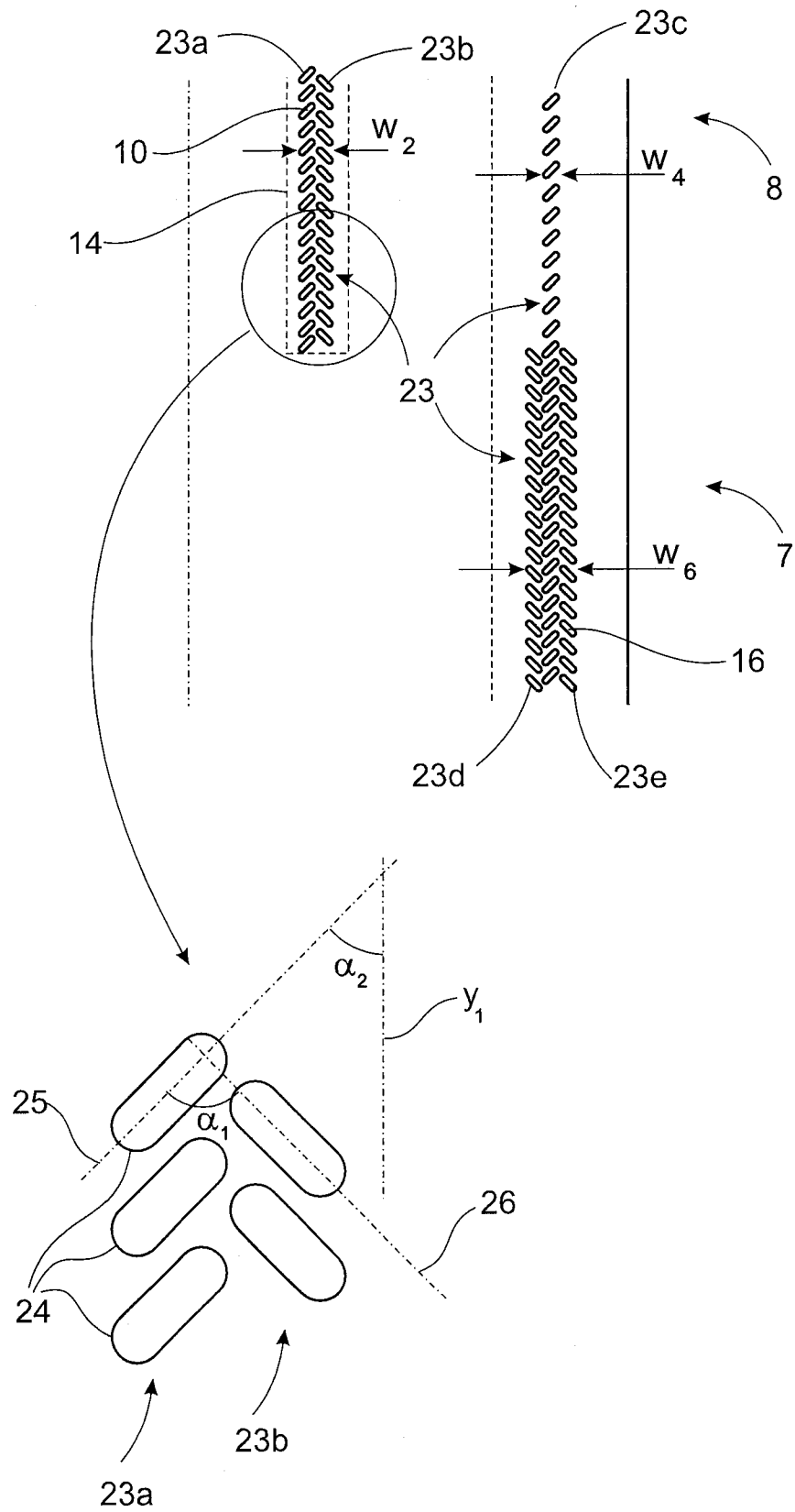

Fig.3

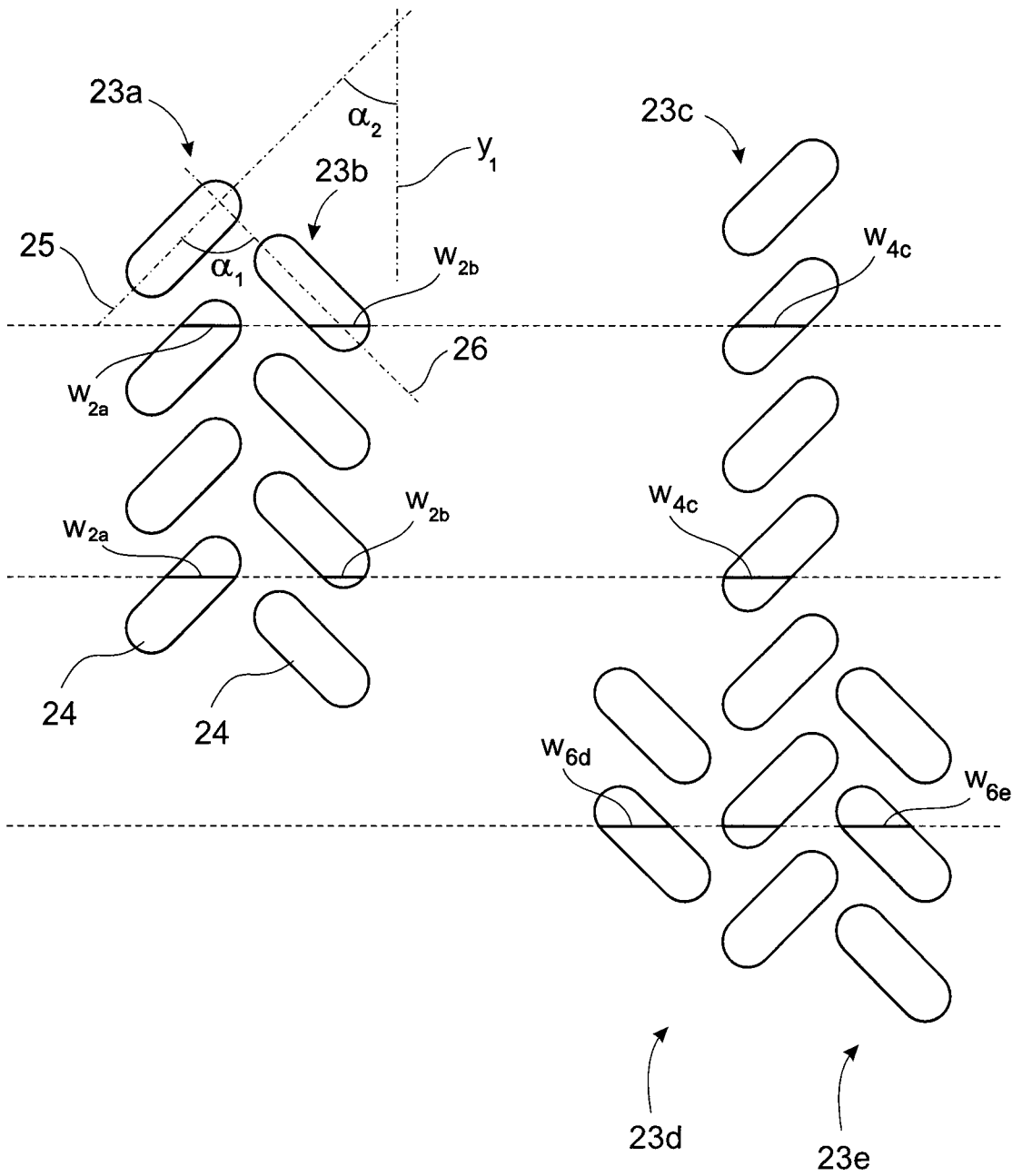

Fig.4